

Institut Français du Pétrole Publications

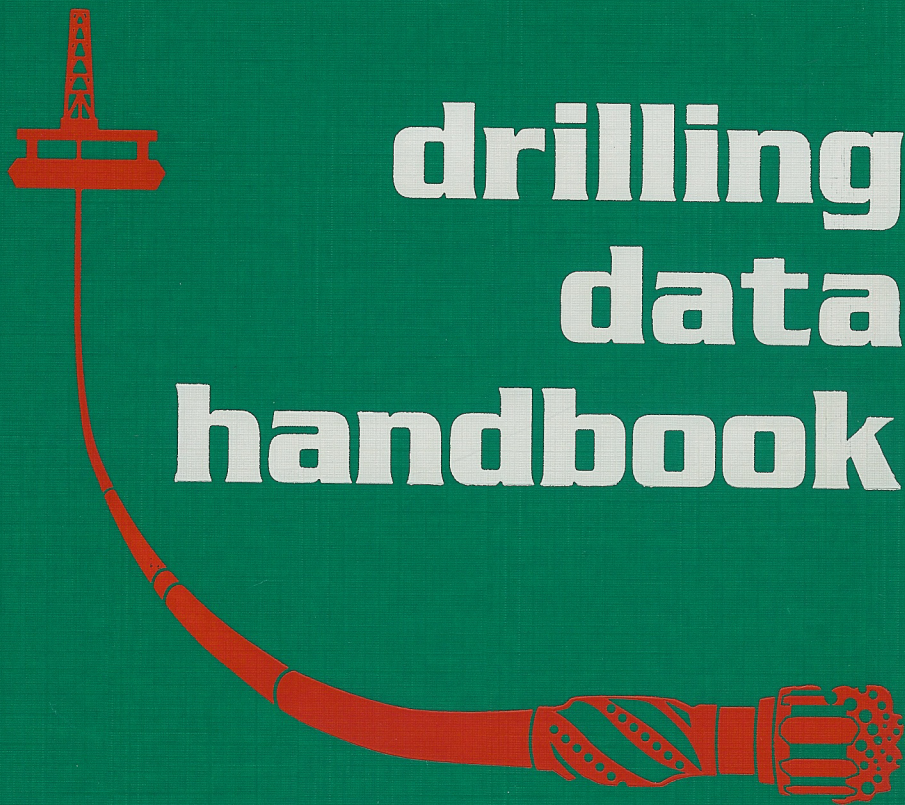

drilling data handbook

Seventh edition

ÉDITIONS TECHNIP

NOTICE

The numerical values and characteristics of the equipment and procedures described in this book are for guidance purposes only, and are not the responsibility of the authors or the companies and organizations mentioned. Further information can be obtained directly from the companies and manufacturers concerned.

Front cover:  **Kolette**

© 1999, Éditions Technip, Paris

All rights reserved. No part of this publication may be reproduced or transmitted in any form or by any means, electronic or mechanical, including photocopy, recording, or any information storage and retrieval system, without the prior written permission of the publisher.

ISBN 2-7108-0756-4

Foreword

to the Seventh Edition

The sixth edition of the Drilling Data Handbook was published in 1991. Over the past ten years, drilling techniques have considerably evolved.

New Specifications and Recommended Practices have been published by the American Petroleum Institute and, in the meantime, manufacturers have also greatly improved their equipment.

In particular, remarkable progress has been achieved in the following fields:

- Horizontal displacements have reached a distance of over ten kilometers in directional and horizontal drilling, with the use of more complex bottom hole assemblies and drill strings.
- Coiled tubing units are now being used almost systematically during workover, and occasionally during drilling.
- The range of drilling bits has been entirely renewed, and the classifications and Used Bit Dull Grading System Format and Codes of the IADC have been modified accordingly.
- New dimensions and weights for casings have appeared with the drilling of HP-HT wells.
- Wellhead equipment and control systems were modified to keep up with deep offshore drilling.

This list is not exhaustive. However, it demonstrates that a new edition of the Drilling Data Handbook was undeniably needed in order to reflect these changes.

We indeed hope that experienced users of this handbook will appreciate the new edition in an environment which is already familiar to them.

A

GENERAL DATA

B

DRILL STRING STANDARDS

C

CASING, TUBING
LINE PIPE STANDARDS

D

CAPACITIES AND
ANNULAR VOLUMES

E

DRILLING BITS
AND DOWNHOLE MOTORS

F

HOISTING AND DERRICK
FLOOR EQUIPMENT

G

PUMPING AND
PRESSURE LOSSES

H

DRILLING MUD

I

CEMENTING

J

DIRECTIONAL DRILLING

K

KICK CONTROL
FISHING

L

WELLHEADS

M

GEOLOGY

INDEX

A

general data

Conversion factor to SI units	A1
Conversion factors.....	A2-A7
Decimal multiples and submultiples of a unit.....	A8
Decimals and metric equivalents of fraction of an inch.....	A9
Temperature conversion table.....	A10
Correspondence between specific gravity and degrees API (at 15.56 °C in relation to water at 15.56°C and 760 mmHg).....	A11
Numerical constant and mathematical formulas.....	A12
Trigonometric formulas.....	A13
Geometry formulas for areas and volumes.....	A14
Inertia of plane surface.....	A15
Content of horizontal cylindrical tank.....	A16
Mechanics and strength of material.....	A17-A19
Electricity. Direct current.....	A20-A21
Electricity. Alternating current.....	A22-A23
Principal chemical symbol, atomic numbers and weights.....	A24
Specific gravity of various materials and fluids.....	A25

Physical properties of metals.....	A26
Stratigraphic scale.....	A27
Buoyancy factor (Steel specific gravity = 7.85).....	A28

CONVERSION FACTORS TO SI UNITS

Multiply	Symbol	by	to obtain	Symbol
Acres		4046.8	Square meters	m ²
Barrels	bbl	0.158984	Cubic meters	m ³
Barrels per day	bbl/d	0.0066243	Cubic meters per hour	m ³ /h
British thermal units	Btu	1055.06	Joules	J
Feet	ft	0.3048	Meters	m
Square feet	ft ²	0.0929	Square meters	m ²
Cubic feet	ft ³	28.302	Liters	l
Cubic feet per barrel	ft ³ /bbl	0.17811088	Cubic meters by cubic meter	m ³ /m ³
Foot.pound-force	ft.lbf	1.35582	Joules	J
Foot.pound-force	ft.lbf	1.3558	Newton.meter	N.m
Gallons (US)	gal (US)	3.7854	Liters	l
Gallons (US) per foot	gal/ft	12.4191	Liters per meter	l/m
Horsepowers	hp	0.7457	Kilowatts	kW
Inches	in	2.54	Centimeters	cm
Square inches	in ²	6.4516	Square centimeters	cm ²
Cubic inches	in ³	16.387064	Cubic centimeters	cm ³
Inches.pound-force	in.lbf	0.1129848	Newton.meter	N.m
kip		4.45E+03	Newton	N
kip per square inch	ksi	6.89E+06	Pascal	Pa
Knot		0.514444	Meters per second	m/s
Miles	mile	1609.3	Meters	m
Square miles	sq mile	258.9998	Hectares	ha
Miles (Nautical)	mile (Nau)	1.853	Kilometers	km
Miles (Statute) <i>land miles</i>	mile (st)	1.6093	Kilometers	km
Pounds per square inches/foot	psi/ft	22.62	Kilopascal/meter	kPa/m
Pounds-force	lbf	4.44822	Newtons	N
Pounds-force per cubic foot	lbf/ft ³	0.0160185	Kilograms-force per liter	kgf/l
Pounds-force per square inch	psi	0.068947448	Bars	bar
Pounds-force per square inch	psi	6.894745	Kilopascals	kPa
Pounds-force/cubic foot	lbf/ft ³	0.01602	Kilogram-force/liter	kgf/l
Pounds-force/gallon	lbf/gal	0.1198	Kilogram-force/liter	kgf/l
Tons-force (long)	lg tonf	1.01605	Tons-force	tf
Tons-force (short)	sh tonf	0.9072	Tons-force	tf
Yards	yd	0.9144027	Meters	m
Square yards	yd ²	3.22831E-07	Square miles	sq mile
Cubic yards	yd ³	764.6	Liters	l

CONVERSION FACTORS

Multiply	Symbol	by	to obtain	Symbol
Acres		0.404686	Hectares	ha
Acres		0.00404686	Square kilometers	km ²
Acres		43560	Square feet	ft ²
Acres		4840	Square yards	yd ²
Acres		43560	Square feet	ft ²
Acres		4840	Square yards	yd ²
Acres		4046.8	Square meters	m ²
Acres		0.00156	Square miles	sq mile
Acres		40.47	Ares	a
Ampere-hour	Ah	3600	Coulomb	C
Ares	a	0.0247096	Acres	
Atmospheres (mean sea level)	atm	29.92	Inches of mercury	inHg
Atmospheres (mean sea level)	atm	14.691	Pounds per square inch	psi
Atmospheres (mean sea level)	atm	76	Centimeters of mercury	cmHg
Atmospheres (mean sea level)	atm	101325	Pascals	Pa
Barrels	bbl	0.158984	Cubic meters	m ³
Barrels	bbl	9702	Cubic inches	in ³
Barrels	bbl	5.6146	Cubic feet	ft ³
Barrels	bbl	34.9726	Imperial gallons	gal (UK)
Barrels	bbl	42	Gallons (US)	gal (US)
Barrels	bbl	158.984	Liters	l
Barrels per day	bbl/d	0.0066243	Cubic meters per hour	m ³ /h
Barrels per foot	bbl/ft	0.5216119	Square meters	m ²
Barrels per inch	bbl/in	6.259343	Square meters	m ²
Bars	bar	14.5038	Pounds-force per square inch	psi
Bars	bar	100 000	Pascals	Pa
Bars	bar	100	Kilopascals	kPa
Bars	bar	0.1	Megapascals	MPa
British thermal units	Btu	1055.06	Joules	J
British thermal units	Btu	0.252075	Kilocalories	kcal
British thermal units per cubic foot	Btu/ft ³	8.90036	Kilocalories per cubic meter	kcal/m ³
British thermal units per pound	Btu/lb	0.55573	Kilocalories per kilogram	kcal/kg
British thermal units per square foot	Btu/ft ²	2.71331396	Kilocalories per square meter	kcal/m ²
Calories	cal	4.186	Joules	J
Centimeters	cm	0.3937	Inches	in
Centimeters	cm	0.01094	Yards	yd
Centimeters	cm	0.03280839	Feet	ft
Centimeters	cm	0.0001	Kilometers	km
Square centimeters	cm ²	0.155	Square inches	in ²
Square centimeters	cm ²	0.00107639	Square feet	ft ²
Square centimeters	cm ²	0.0001	Square meters	m ²
Cubic centimeters	cm ³	0.0610236	Cubic inches	in ³
Cubic centimeters	cm ³	0.0353	Cubic feet	ft ³
Cubic centimeters	cm ³	0.0000013	Cubic yards	yd ³
Cubic centimeters	cm ³	0.001	Liters	l
Centimeters of mercury	cmHg	0.01315789	Atmospheres (mean sea level)	atm
Centipoises	cP	0.001	Pascals.second	Pa.s
Centistokes	cSt	0.0000001	Square meter.second	m ² .s
Coulombs	C	0.0002777	Ampere-hour	Ah

CONVERSION FACTORS (continued)

Multiply	Symbol	by	to obtain	Symbol
Daltons		1.66E-27	Kilograms	kg
Darcies	D	9.87E-13	Square meters	m ²
Decanewtons	daN	1.02	Kilograms-force	kgf
Decanewtons	daN	2.2482014	Pounds-force	lbf
Decanewtons.meters	daN.m	7.3746312	Feet.pound-force	ft.lbf
Decanewtons.meters	daN.m	10	Newtons.meters	N.m
Degree (angle)		1.75E-02	Radians	rad
Electronvolts	eV	1.60E-19	Joules	J
Fathoms	fth	1.8288	Meters	m
Feet	ft	0.3048	Meters	m
Feet	ft	0.3333	Yards	yd
Feet	ft	30.48	Centimeters	cm
Feet	ft	0.0003048	Kilometers	km
Feet	ft	0.0001894	Miles	mile
Feet	ft	12	Inches	in
Square feet	ft ²	144	Square inches	in ²
Square feet	ft ²	0.1111	Square yards	yd ²
Square feet	ft ²	0.0929	Square meters	m ²
Square feet	ft ²	929.03	Square centimeters	cm ²
Square feet	ft ²	2.2957E-05	Acres	
Cubic feet	ft ³	28.302	Liters	l
Cubic feet	ft ³	0.02832	Cubic meters	m ³
Cubic feet	ft ³	1728	Cubic inches	in ³
Cubic feet	ft ³	0.03704	Cubic yards	yd ³
Cubic feet	ft ³	7.4805	Gallons (US)	gal (US)
Cubic feet	ft ³	6.288	Imperial gallons	gal (UK)
Cubic feet	ft ³	0.17811	Barrels	bbl
Cubic feet	ft ³	28320	Cubic centimeters	cm ³
Cubic feet per barrel	ft ³ /bbl	0.17811088	Cubic meters by cubic meter	m ³ /m ³
Feet.pounds-force	ft.lbf	1.35582	Joules	J
Feet.pounds-force	ft.lbf	0.138255	Kilograms.meters	kg.m
Feet.pounds-force	ft.lbf	1.3558	Newtons.meters	N.m
Feet.pounds-force	ft.lbf	0.1356	Decanewtons.meters	daN.m
Gallons (imperial)	gal (UK)	277.42	Cubic inches	in ³
Gallons (imperial)	gal (UK)	0.0045461	Cubic meters	m ³
Gallons (imperial)	gal (UK)	4.54595	Liters	l
Gallons (imperial)	gal (UK)	0.0285938	Barrels	bbl
Gallons (imperial)	gal (UK)	0.159033	Cubic feet	ft ³
Gallons (imperial)	gal (UK)	1.200912	Gallons (US)	gal (US)
Gallons (US)	gal (US)	128	Ounces	oz
Gallons (US)	gal (US)	4	Quarts	qt
Gallons (US)	gal (US)	8	Pints	
Gallons (US)	gal (US)	0.8327	Imperial gallons	gal (UK)
Gallons (US)	gal (US)	231	Cubic inches	in ³
Gallons (US)	gal (US)	0.02380952	Barrels	bbl
Gallons (US)	gal (US)	3.7854	Liters	l
Gallons (US)	gal (US)	0.0037854	Cubic meters	m ³
Gallons (US) per barrel	gal/bbl	23.81	Liters per cubic meter	l/m ³
Gallons (US) per foot	gal/ft	12.4191	Liters/meter	l/m
Grains-force	grf	0.0647987	Grams-force	gf
Grams-force	gf	15.4324	Grains-force	grf
Grams-force	gf	0.035274	Ounces-force	ozf

CONVERSION FACTORS (continued)

Multiply	Symbol	by	to obtain	Symbol
Hectares	ha	2.47105	Acres	
Hectares	ha	10 000	Square meters	m ²
Hectares	ha	0.00386101	Square miles	sq mile
Hectares	ha	10 000	Square meters	m ²
Horsepowers	hp	0.7457	Kilowatts	kW
Horsepowers	hp	1.01387	Steam horsepowers	ch
Horsepowers	hp	745.701	Watts	W
Horsepowers (steam)	ch	0.98632	Horsepowers	hp
Horsepowers (steam)	ch	735.498	Watts	W
Inches	in	25.4	Millimeters	mm
Inches	in	2.54	Centimeters	cm
Inches	in	0.0833333	Feet	ft
Inches	in	0.02777	Yards	yd
Square inches	in ²	6.4516	Square centimeters	cm ²
Square inches	in ²	0.00694444	Square feet	ft ²
Square inches	in ²	0.0007716	Square yards	yd ²
Square inches	in ²	0.00064516	Square meters	m ²
Cubic inches	in ³	16.3871027	Cubic centimeters	cm ³
Cubic inches	in ³	0.00010307	Barrels	bbl
Cubic inches	in ³	0.0005787	Cubic feet	ft ³
Cubic inches	in ³	0.0163865	Liters	l
Cubic inches	in ³	0.5541	Ounces	oz
Cubic inches	in ³	0.0173	Quarts	qt
Cubic inches	in ³	0.004329	Gallons (US)	gal (US)
Cubic inches	in ³	0.0036046	Imperial gallon	gal (UK)
Cubic inches	in ³	1.6387E-05	Cubic meters	m ³
Cubic inches	in ³	2.1433E-05	Cubic yards	yd ³
Inches of mercury	inHg	0.03342246	Atmospheres (mean sea level)	atm
Inches of mercury	inHg	1333.22	Pascals	Pa
Inches of mercury	inHg	0.4912	Pounds-force per square inch	psi
Inches.pounds-force	in.lbf	0.1129848	Newtons.meters	N.m
Joules	J	6.2415E+18	Electronvolts	eV
Joules	J	0.23889154	Calories	cal
Joules	J	0.737561	Feet.pounds-force	ft.lbf
Joules	J	0.00094781	British thermal units	Btu
Kilocalories	kcal	3.96707	British thermal units	Btu
Kilocalories per cubic meter	kcal/m ³	0.112355	British thermal units per cubic foot	Btu/ft ³
Kilocalories per kilogram	kcal/kg	1.79943	British thermal units per pound	Btu/lb
Kilocalories per square meter	kcal/m ²	0.368553	British thermal units per square foot	Btu/ft ²
Kilograms-force	kgf	2.204586	Pounds-force	lbf
Kilograms-force	kgf	0.00098425	Long tons-force	lg tonf
Kilograms-force	kgf	0.001	Tons-force	tf
Kilograms-force	kgf	2.20462	Pounds-force	lbf
Kilograms-force	kgf	0.0234534	Sacks (cement)	
Kilograms-force	kgf	0.0011023	Short tons-force	sh tonf
Kilograms-force	kgf	9.81	Newtons	N
Kilograms-force	kgf	0.981	Decanewtons	daN
Kilograms-force per cubic meter	kgf/m ³	0.3505	Pounds-force per barrel	lbf/bbl
Kilograms-force per cubic meter	kgf/m ³	0.35050001	Pounds-force per barrel	lbf/bbl
Kilograms-force per liter	kgf/l	8.34523	Pounds-force per gallon (US)	lbf/gal
Kilograms-force per liter	kgf/l	62.4278	Pounds-force per cubic foot	lbf/ft ³

CONVERSION FACTORS (continued)

Multiply	Symbol	by	to obtain	Symbol
Kilograms-force per meter	kgf/m	0.671971	Pounds-force per foot	lbf/ft
Kilograms-force per square centimeter	kgf/cm ²	14.2233	Pound-force per square inch	psi
Kilograms-force per square millimeter	kgf/mm ²	0.711167	Short tons-force per square inch	sh tonf/in ²
Kilograms-force per square millimeter	kgf/mm ²	102.408	Short tons-force per square foot	sh tonf/ft ²
Kilograms-force.meters	kgf.m	9.81	Newtons.meters	N.m
Kilograms-force.meters	kgf.m	7.23301	Feet.pounds-force	ft.lbf
Kilograms-force/liter	kgf/l	8.3472454	Pounds-force/gallon	lbf/gal
Kilograms-force/liter	kgf/l	62.421972	Pounds-force/cubic foot	lbf/ft ³
Kilometers	km	0.621373	Statute miles (land miles)	mile (st)
Kilometers	km	0.539613	Nautical miles (UK sea miles)	mile (Nau) UK
Kilometers	km	0.539957	Nautical miles (other countries)	mile (Nau)
Kilometers	km	3280.83	Feet	ft
Kilometers	km	1093.61	Yards	yd
Kilometers	km	1000	Meters	m
Kilometers	km	10000	Centimeters	cm
Kilometers	km	0.621388	Miles	mile
Kilometers	km	0.539957	Nautical miles	mile (Nau)
Square kilometers	km ²	0.386102	Square miles	sq mile
Square kilometers	km ²	247.1	Acres	
Kilopascals	kPa	0.145038	Pounds-force per square inch	psi
Kilopascals	kPa	0.01	Bars	bar
Kilopascal/meter	kPa/m	0.0442086	Pounds square inches/foot	psi/ft
Kilowatt-hours	kWh	3.60E+06	Joules	J
Kilowatts	kW	1.34102	Horsepowers	hp
kips		4.45E+03	Newtons	N
kips per square inch	ksi	6.89E+06	Pascals	Pa
Knots		0.514444	Meters per second	m/s
Liters	l	61.025844	Cubic inches	in ³
Liters	l	0.0353147	Cubic feet	ft ³
Liters	l	0.264178	Gallons (US)	gal (US)
Liters	l	0.219976	Imperial gallons	gal (UK)
Liters	l	0.00628994	Barrels	bbl
Liters	l	1000	Cubic centimeters	cm ³
Liters	l	1.0567	Quarts	qt
Liters	l	0.0013	Cubic yards	yd ³
Liters	l	0.001	Cubic meters	m ³
Liters per cubic meter	l/m ³	0.042	Gallons (US) per barrel	gal/bbl
Liters/meter	l/m	0.0805214	Gallons (US) per foot	gal/ft
Megapascals	MPa	10	Bars	bar
Megapascals	MPa	145.038	Pounds-force per square inch	psi
Meters	m	3.28084	Feet	ft
Meters	m	1.09361	Yards	yd
Meters	m	0.001	Kilometers	km
Meters	m	0.00062137	Miles	mile
Meters	m	1000	Millimeters	mm
Square meters	m ²	0.15976117	Barrels per inch	bbl/in
Square meters	m ²	1.91713417	Barrels per foot	bbl/ft
Square meters	m ²	10.7639	Square feet	ft ²
Square meters	m ²	0.0002471	Acres	

CONVERSION FACTORS (continued)

Multiply	Symbol	by	to obtain	Symbol
Square meters	m ²	1550	Square inches	in ²
Square meters	m ²	1.1959	Square yards	yd ²
Square meters	m ²	10 000	Square centimeters	cm ²
Square meters	m ²	0.0001	Hectares	ha
Cubic meters	m ³	35.3147	Cubic feet	ft ³
Cubic meters	m ³	6.28994	Barrels (US)	bbl
Cubic meters	m ³	219.96876	Imperial gallons	gal (UK)
Cubic meters	m ³	61023.38	Cubic inches	in ³
Cubic meters	m ³	1.30796	Cubic yards	yd ³
Cubic meters	m ³	1000	Liters	l
Cubic meters	m ³	264.17	Gallons (US)	gal (US)
Cubic meters by cubic meter	m ³ /m ³	5.61448	Cubic feet per barrel	ft ³ /bbl
Cubic meters per hour	m ³ /h	150.959	Barrels per day	bbl/d
Miles	mile	5280	Feet	ft
Miles	mile	1760	Yards	yd
Miles	mile	1609.3	Meters	m
Miles	mile	1.6093	Kilometers	km
Miles	mile	0.8684	Nautical miles	mile (Nau)
Miles	mile	0.86840005	Nautical miles	mile (Nau)
Square miles	sq mile	641.025	Acres	
Square miles	sq mile	3097600	Square yards	yd ²
Square miles	sq mile	258.9998	Hectares	ha
Square miles	sq mile	2.5899	Square kilometers	km ²
Miles (Nautical)	mile (Nau)	1.151543	Miles	mile
Miles (Nautical)	mile (Nau)	1.853	Kilometers	km
Miles (statute) <i>land miles</i>	mile (st)	1.6093	Kilometers	km
Millimeters	mm	0.03937	Inches	in
Millimeters	mm	0.001	Meters	m
Newtons	N	0.102	Kilograms-force	kgf
Newtons	N	0.224809	Pounds-force	lbf
Newtons	N	0.22480902	Pounds-force	lbf
Newtons.meters	N.m	0.1	Decanewtons.meters	daN.m
Newtons.meters	N.m	0.102	Kilograms-force.meters	kgf.m
Newtons.meters	N.m	0.737561	Feet pounds-force	ft.lbf
Ounces	oz	1.804728	Cubic inches	in ³
Ounces	oz	0.0078125	Gallons (US)	gal (US)
Ounces	oz	0.0625	Pounds	lbf
Ounces-force	ozf	28.34949	Grams-force	gf
Pascals	Pa	0.00001	Bars	bar
Pints		0.125	Gallons (US)	gal (US)
Pounds-force	lbf	0.4448	Decanewtons	daN
Pounds-force	lbf	0.00044643	Long tons-force	lg tonf
Pounds-force	lbf	0.0005	Short tons-force	sh tonf
Pounds-force	lbf	16	Ounces-force	ozf
Pounds-force	lbf	0.0005	Short tons-force	sh tonf
Pounds-force	lbf	0.4536	Kilograms-force	kgf
Pounds-force	lbf	4.44822	Newtons	N
Pounds-force per barrel	lbf/bbl	2.853067	Kilograms-force per cubic meter	kgf/m ³
Pounds-force per cubic foot	lbf/ft ³	0.0160185	Kilograms-force per liter	kgf/l
Pounds-force per foot	lbf/ft	1.4881594	Kilograms-force per meter	kgf/m

CONVERSION FACTORS (continued)

Multiply	Symbol	by	to obtain	Symbol
Pounds-force per square inch	psi	0.06894745	Bars	bar
Pounds-force per square inch	psi	0.07030717	Kilograms-force per square centimeter	kgf/cm ²
Pounds-force per square inch	psi	6.894745	Kilopascals	kPa
Pounds-force per square inch	psi	0.00689474	Megapascals	MPa
Pounds-force per square inch	psi	2.03583062	Inches of mercury	inHg
Pounds-force per square inch	psi	0.06804	Atmospheres	atm
Pounds-force per square inches/foot	psi/ft	22.62	Kilopascals/meter	kPa/m
Pounds-force/gallon	lbf/gal	0.1198	Kilogram-force/liter	kgf/l
Quarts	qt	0.25	Gallons (US)	gal (US)
Quarts	qt	57.8034682	Cubic inches	in ³
Quarts	qt	0.94634239	Liters	l
rpm		0.1047198	Radians per second	rad/s
Sacks (cement)		42.6377412	Kilograms-force	kgf
Tons-force	tf	1000	Kilograms-force	kg
Tons-force	tf	0.9842	Long tons-force	lg tonf
Tons-force	tf	1.10231	Short tons-force	sh tonf
Tons-force.kilometers	tf.km	0.684944	Short tons-force.miles	sh tonf.mile
Tons-force (long)	lg tonf	1016	Kilograms-force	kgf
Tons-force (long)	lg tonf	2240	Pounds-force	lbf
Tons-force (long)	lg tonf	1.01605	Tons-force	tf
Tons-force (long)	lg tonf	1.12	Short tons-force	sh tonf
Tons-force (short)	sh tonf	0.89287	Long tons-force	lg tonf
Tons-force (short)	sh tonf	2000	Pounds-force	lbf
Tons-force (short)	sh tonf	0.8929	Long tons-force	lg tonf
Tons-force (short)	sh tonf	0.9072	Tons-force	tf
Tons-force (short)	sh tonf	907.194	Kilograms-force	kgf
Tons-force (short).miles	sh tonf.mile	1.45997337	Tons-force.kilometers	tf.km
Tons-force (short) per square foot	sh tonf/ft ²	0.00976486	Kilograms-force per square millimeter	kgf/mm ²
Tons-force (short) per square inch	sh tonf/in ²	1.40613949	Kilograms-force per square millimeter	kgf/mm ²
Yards	yd	91.44027	Centimeters	cm
Yards	yd	0.9144027	Meters	m
Yards	yd	3	Feet	ft
Yards	yd	36	Inches	in
Yards	yd	0.0009144	Kilometers	km
Yards	yd	0.00056818	Miles	mile
Square yards	yd ²	0.00020661	Acres	
Square yards	yd ²	9	Square feet	ft ²
Square yards	yd ²	1296	Square inches	in ²
Square yards	yd ²	0.83619032	Square meters	m ²
Square yards	yd ²	3.2283E-07	Square miles	sq mile
Cubic yards	yd ³	46656	Cubic inches	in ³
Cubic yards	yd ³	764559.4	Cubic centimeters	cm ³
Cubic yards	yd ³	27	Cubic feet	ft ³
Cubic yards	yd ³	46656	Cubic inches	in ³
Cubic yards	yd ³	764.6	Liters	l
Cubic yards	yd ³	0.76454937	Cubic meters	m ³
Watts	W	0.00134102	Horsepowers	hp
Watt-hours	Wh	3600	Joules	J

DECIMAL MULTIPLES AND SUBMULTIPLES OF A UNIT

Multiples

Unit multiplier	Prefix to put before the name of the unit	Symbol to put before the unit symbol
$10^{12} = 1\ 000\ 000\ 000\ 000$	tera	T
$10^9 = 1\ 000\ 000\ 000$	giga	G
$10^6 = 1\ 000\ 000$	mega	M
$10^3 = 1\ 000$	kilo	k
$10^2 = 100$	hecto	h
$10^1 = 10$	deca	da

Submultiples

Unit multiplier	Prefix to put before the name of the unit	Symbol to put before the unit symbol
$10^{-1} = 0.1$	deci	d
$10^{-2} = 0.01$	centi	c
$10^{-3} = 0.001$	milli	m
$10^{-6} = 0.000\ 001$	micro	μ
$10^{-9} = 0.000\ 000\ 001$	nano	n
$10^{-12} = 0.000\ 000\ 000\ 001$	pico	p
$10^{-15} = 0.000\ 000\ 000\ 000\ 001$	femto	f
$10^{-18} = 0.000\ 000\ 000\ 000\ 000\ 001$	atto	a

Examples: 1 megameter (Mm) = 10^6 meters (m)

1 micrometer (μm) (micron or μ) = 10^{-6} meters (m)

DECIMAL AND METRIC EQUIVALENTS OF FRACTIONS OF AN INCH

Fraction		Decimal equivalent	(mm)	Fraction		Decimal equivalent	(mm)
1/16	1/64	0.015625	0.39688	9/16	33/64	0.515625	13.09690
	1/32	0.031250	0.79375		17/32	0.531250	13.49378
	3/64	0.046875	1.19063		35/64	0.546875	13.89065
		0.062500	1.58750			0.562500	14.28753
1/8	5/64	0.078125	1.98438	5/8	37/64	0.578125	14.68440
	3/32	0.093750	2.38125		19/32	0.593750	15.08128
	7/64	0.109375	2.77813		39/64	0.609375	15.47816
		0.125000	3.17501			0.625000	15.87503
3/16	9/64	0.140625	3.57188	11/16	41/64	0.640625	16.27191
	5/32	0.156250	3.96876		21/32	0.656250	16.66878
	11/64	0.171875	4.36563		43/64	0.671875	17.06566
		0.187500	4.76251			0.687500	17.46253
1/4	13/64	0.203125	5.15939	3/4	45/64	0.703125	17.85941
	7/32	0.218750	5.55626		23/32	0.718750	18.25629
	15/64	0.234375	5.95314		47/64	0.734375	18.65316
		0.250000	6.35001			0.750000	19.05004
5/16	17/64	0.265625	6.74689	13/16	49/64	0.765625	19.44691
	9/32	0.281250	7.14376		25/32	0.781250	19.84379
	19/64	0.296875	7.54064		51/64	0.796875	20.24067
		0.312500	7.93752			0.812500	20.63754
3/8	21/64	0.328125	8.33439	7/8	53/64	0.828125	21.03442
	11/32	0.343750	8.73127		27/32	0.843750	21.43129
	23/64	0.359375	9.12814		55/64	0.859375	21.82817
		0.375000	9.52502			0.875000	22.22504
7/16	25/64	0.390625	9.92189	15/16	57/64	0.890625	22.62192
	13/32	0.406250	10.31877		29/32	0.906250	23.01880
	27/64	0.421875	10.71565		59/64	0.921875	23.41567
		0.437500	11.11252			0.937500	23.81255
1/2	29/64	0.453125	11.50940	31/32	61/64	0.953125	24.20942
	15/32	0.468750	11.90627		31/32	0.968750	24.60630
	31/64	0.484375	12.30315		63/64	0.984375	25.00318
	0.500000	12.70003	1		1.000000	25.40005	

TEMPERATURE CONVERSION TABLE

$$\left(t^{\circ}\text{F} = \frac{9}{5}(t^{\circ}\text{C} + 32) \quad t^{\circ}\text{C} = \frac{5}{9}(t^{\circ}\text{F} - 32) \right)$$

Example: The central figures refer to the temperatures either in degrees Celsius or degrees Fahrenheit which require conversion. The corresponding temperatures in degrees Fahrenheit or degrees Celsius will be found to the right or left respectively.

C	F
6.67	111.2
44	111.2

44° Fahrenheit → 6.67° Celsius
 44° Celsius → 111.2° Fahrenheit

°C	°F	°C	°F	°C	°F	°C	°F	°C	°F	°C	°F
-56.7	-70	11.10	53.6	11.1	125.6	33.3	92	216	788	420	788
-53.9	-65	10.00	57.2	12.2	129.2	34.4	94	227	824	440	824
-51.2	-60	8.89	60.8	13.3	132.8	35.6	96	238	860	460	860
-48.4	-55	7.78	64.4	14.4	136.4	36.7	98	249	896	480	896
-45.6	-50	6.67	68.0	15.6	140.0	37.8	100	260	932	500	932
-42.8	-45	5.55	71.6	16.7	143.6	48.9	120	271	968	520	968
-40.0	-40	4.44	75.2	17.8	147.2	60.0	140	282	1004	540	1004
-37.2	-35	3.33	78.8	18.9	150.8	71.1	160	293	1040	560	1040
-34.4	-30	2.22	82.4	20.0	154.4	82.2	180	304	1076	580	1076
-31.7	-25	1.11	86.0	21.1	158.0	93.3	200	316	1112	600	1112
-28.9	-20	0.00	89.6	22.2	161.6	104.4	220	327	1148	620	1148
-26.1	-15	1.11	93.2	23.3	165.2	115.6	240	328	1184	640	1184
-23.3	-10	2.22	96.8	24.4	168.8	126.7	260	349	1220	660	1220
-20.6	-5	3.33	100.4	25.6	172.4	137.8	280	360	1256	680	1256
-17.8	0	4.44	104.0	26.7	176.0	148.9	300	371	1292	700	1292
-15.6	5	5.55	107.6	27.8	179.6	160.0	320	382	1328	720	1328
-14.4	10	6.67	111.2	28.9	183.2	171.0	340	393	1364	740	1364
-13.3	15	7.78	114.8	30.0	186.8	182.0	360	404	1400	760	1400
-12.2	20	8.89	118.4	31.1	190.4	193.0	380	416	1436	780	1436
	25	10.00	122.0	32.2	194.0	204.0	400	427	1472	800	1472

Interpolation table

°C	0.56	1.11	1.67	2.22	2.78	3.33	3.89	4.44	5	5.56	6.11	6.67	7.22	7.78	8.33	8.89	9.44	10	10.56	11.11
	1	2	3	4	5	6	7	8	9	10	11	12	13	14	15	16	17	18	19	20
°F	1.8	3.6	5.4	7.2	9	10.8	12.6	14.4	16.2	18	19.8	21.6	23.4	25.2	27	28.8	30.6	32.4	34.2	36

CORRESPONDENCE BETWEEN SPECIFIC GRAVITY AND DEGREES API (at 15.56°C in relation to water at 15.56°C and 760 mmHg)

Specific gravity	Degrees API	Specific gravity	Degrees API	Specific gravity	Degrees API	Specific gravity	Degrees API	Specific gravity	Degrees API	Specific gravity	Degrees API	Specific gravity	Degrees API	Specific gravity	Degrees API	Specific gravity	Degrees API	Specific gravity	Degrees API
0.600	104.3	0.650	86.2	0.700	70.6	0.750	57.2	0.800	45.4	0.850	35.0	0.900	25.7	0.950	17.4	1.000	10.0		
0.602	103.5	0.652	85.5	0.702	70.1	0.752	56.7	0.802	44.9	0.852	34.6	0.902	25.4	0.952	17.1	1.002	9.7		
0.604	102.8	0.654	84.9	0.704	69.5	0.754	56.2	0.804	44.5	0.854	34.2	0.904	25.0	0.954	16.8	1.004	9.4		
0.606	102.0	0.656	84.2	0.706	68.9	0.756	55.7	0.806	44.1	0.856	33.8	0.906	24.7	0.956	16.5	1.006	9.2		
0.608	101.2	0.658	83.5	0.708	68.4	0.758	55.2	0.808	43.6	0.858	33.4	0.908	24.3	0.958	16.2	1.008	8.9		
0.610	100.5	0.660	82.9	0.710	67.8	0.760	54.7	0.810	43.2	0.860	33.0	0.910	24.0	0.960	15.9	1.010	8.6		
0.612	99.7	0.662	82.2	0.712	67.2	0.762	54.2	0.812	42.8	0.862	32.7	0.912	23.7	0.962	15.6	1.012	8.3		
0.614	99.0	0.664	81.6	0.714	66.7	0.764	53.7	0.814	42.3	0.864	32.3	0.914	23.3	0.964	15.3	1.014	8.0		
0.616	98.2	0.666	81.0	0.716	66.1	0.766	53.2	0.816	41.9	0.866	31.9	0.916	23.0	0.966	15.0	1.016	7.8		
0.618	97.5	0.668	80.3	0.718	65.6	0.768	52.7	0.818	41.5	0.868	31.5	0.918	22.6	0.968	14.7	1.018	7.5		
0.620	96.7	0.670	79.7	0.720	65.0	0.770	52.3	0.820	41.1	0.870	31.1	0.920	22.3	0.970	14.4	1.020	7.2		
0.622	96.0	0.672	79.1	0.722	64.5	0.772	51.8	0.822	40.6	0.872	30.8	0.922	22.0	0.972	14.1	1.022	7.0		
0.624	95.3	0.674	78.4	0.724	63.9	0.774	51.3	0.824	40.2	0.874	30.4	0.924	21.6	0.974	13.8	1.024	6.7		
0.626	94.5	0.676	77.8	0.726	63.4	0.776	50.8	0.826	39.8	0.876	30.0	0.926	21.3	0.976	13.5	1.026	6.4		
0.628	93.8	0.678	77.2	0.728	62.9	0.778	50.4	0.828	39.4	0.878	29.7	0.928	21.0	0.978	13.2	1.028	6.1		
0.630	93.1	0.680	76.6	0.730	62.3	0.780	49.9	0.830	39.0	0.880	29.3	0.930	20.7	0.980	12.9	1.030	5.9		
0.632	92.4	0.682	76.0	0.732	61.8	0.782	49.4	0.832	38.6	0.882	28.9	0.932	20.3	0.982	12.6	1.032	5.6		
0.634	91.7	0.684	75.4	0.734	61.3	0.784	49.0	0.834	38.2	0.884	28.6	0.934	20.0	0.984	12.3	1.034	5.3		
0.636	91.0	0.686	74.8	0.736	60.8	0.786	48.5	0.836	37.8	0.886	28.2	0.936	19.7	0.986	12.0	1.036	5.1		
0.638	90.3	0.688	74.2	0.738	60.2	0.788	48.1	0.838	37.4	0.888	27.8	0.938	19.4	0.988	11.7	1.038	4.8		
0.640	89.6	0.690	73.6	0.740	59.7	0.790	47.6	0.840	37.0	0.890	27.5	0.940	19.0	0.990	11.4	1.040	4.6		
0.642	88.9	0.692	73.0	0.742	59.2	0.792	47.2	0.842	36.6	0.892	27.1	0.942	18.7	0.992	11.1	1.042	4.3		
0.644	88.2	0.694	72.4	0.744	58.7	0.794	46.7	0.844	36.2	0.894	26.8	0.944	18.4	0.994	10.9	1.044	4.0		
0.646	87.5	0.696	71.8	0.746	58.2	0.796	46.3	0.846	35.8	0.896	26.4	0.946	18.1	0.996	10.6	1.046	3.8		
0.648	86.9	0.698	71.2	0.748	57.7	0.798	45.8	0.848	35.4	0.898	26.1	0.948	17.8	0.998	10.3	1.048	3.5		

Approximate temperature correction to obtain temperatures at 15°C

- add if $t > 15^\circ\text{C}$
- subtract if $t < 15^\circ\text{C}$

Specific gravity	Correction for 1°C
0.600 to 0.700	0.0009
0.700 to 0.800	0.0008
0.800 to 0.840	0.00075
0.840 to 0.880	0.0007
0.880 to 0.920	0.00065
0.920 to 1.000	0.0006

$$\text{Degrees API} = \frac{141.5}{d(15.56^\circ\text{C}/15.56^\circ\text{C})} - 131.5$$

$$d(15.56^\circ\text{C}/15.56^\circ\text{C}) = \text{Specific gravity } (60^\circ\text{F}/60^\circ\text{F})$$

NUMERICAL CONSTANTS AND MATHEMATICAL FORMULAS

π	3.1415927	$\frac{1}{\pi}$	0.3183099	$\frac{\pi}{2}$	1.5707963	$\frac{\pi}{180}$	0.0174533
π^2	9.8696044	$\frac{1}{\pi^2}$	0.1013212	$\frac{\pi}{3}$	1.0471976	$\frac{\pi}{200}$	0.0157080
π^3	31.0062767	$\frac{1}{\pi^3}$	0.0322515	$\frac{\pi}{4}$	0.7853982	$\frac{180}{\pi}$	57.2957795
$\sqrt{\pi}$	1.7724539	$\frac{1}{\sqrt{\pi}}$	0.5641896	$\frac{4\pi}{3}$	4.1887902	$\frac{200}{\pi}$	63.6619763
$\sqrt[3]{\pi}$	1.4645919	$\frac{1}{\sqrt[3]{\pi}}$	0.6827840				
$\sqrt{2}$	1.414214	$\sqrt{3}$	1.732051	$\sqrt{5}$	2.236068	$\sqrt{10}$	3.162278
$\frac{1}{\sqrt{2}}$	0.70711	$\frac{1}{\sqrt{3}}$	0.57735	$\frac{1}{\sqrt{5}}$	0.44721	$\frac{1}{\sqrt{10}}$	0.31623
e	2.7182818	$\frac{1}{e}$	0.3678794	$\log_{10} e = 0.4342945$		$g = 9.80665 \text{ m/s}^2$	
$\frac{1}{\log_{10} e} = \text{colog } e = \log_e 10 = 2.3025851$				$\log_e x = 2.3025851 \log_{10} x$		$\log_{10} x = 0.4342945 \log_e x$	
Arithmetic progression					a = first term r = common difference n = number of terms ℓ = last term = $a + (n - 1)r$		
$a \quad a+r \quad a+2r \quad a+3r \quad \dots \quad a+(n-1)r$ $S_n = \left(\frac{a+\ell}{2}\right)n = \frac{n}{2}[2a+(n-1)r]$							
Geometric progression					a = first term r = common ratio n = number of terms ℓ = last term = aq^{n-1}		
$a \quad aq \quad aq^2 \quad aq^3 \quad \dots \quad aq^{n-1}$ Si $q \neq 1 \quad S_n = \frac{\ell q - a}{q - 1} = a \frac{(q^n - 1)}{q - 1}$							

Miscellaneous constants

- 0.0764 = air density in lb/ft³ at 60°F and 14.7 psia
- 14.691 = normal atmospheric pressure (76 cmHg) in psi
- 32.174 = gravitational acceleration in ft/s² (980.655 cm/s²)
- 550 = number of lb.ft/s one horsepower (hp)
- 778.2 = number of lb.ft in one Btu
- 62.43 = water density in lbf/ft³ at 4°C
- 8.345 = water density in lbf/gal at 4°C
- °C + 273.16 = K (Kelvin)
- °F + 459.69 = °R (Rankine)

TRIGONOMETRIC FORMULAS

DEFINITION

$$\cos \alpha = \frac{OP}{OM}$$

$$\sin \alpha = \frac{PM}{OM} \quad \cotan \alpha = \frac{1}{\tan \alpha} = \frac{OP}{PM}$$

$$\tan \alpha = \frac{PM}{OP}$$

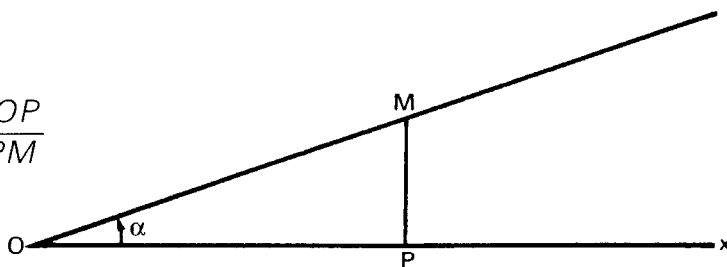

GEOMETRIC INTERPRETATION

$$\overline{OA} = \overline{OM} = R = 1$$

$$\overline{OQ} = \sin \alpha$$

$$\overline{OP} = \cos \alpha$$

$$\overline{AT} = \tan \alpha$$

$$\overline{BT'} = \cotan \alpha$$

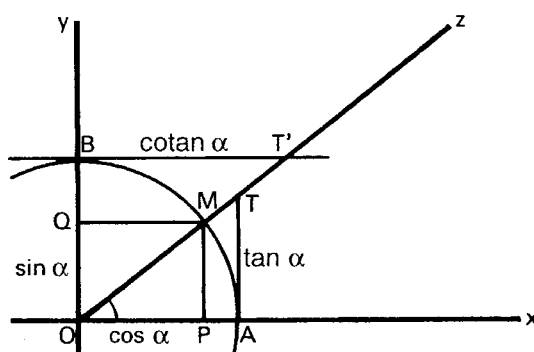

TRIGONOMETRIC RELATIONS

$$\cos^2 \alpha + \sin^2 \alpha = 1$$

$$\tan \alpha = \frac{\sin \alpha}{\cos \alpha}$$

$$\cotan \alpha = \frac{\cos \alpha}{\sin \alpha} = \frac{1}{\tan \alpha}$$

$$\sin 2\alpha = 2 \sin \alpha \cos \alpha$$

$$\cos 2\alpha = \cos^2 \alpha - \sin^2 \alpha = 1 - 2 \sin^2 \alpha$$

$$\tan 2\alpha = \frac{2 \tan \alpha}{1 - \tan^2 \alpha}$$

$$\sin(\alpha + \beta) = \sin \alpha \cos \beta + \cos \alpha \sin \beta$$

$$\cos(\alpha + \beta) = \cos \alpha \cos \beta - \sin \alpha \sin \beta$$

$$\sin(\alpha - \beta) = \sin \alpha \cos \beta - \cos \alpha \sin \beta$$

$$\tan(\alpha + \beta) = \frac{\tan \alpha + \tan \beta}{1 - \tan \alpha \tan \beta}$$

$$\tan(\alpha - \beta) = \frac{\tan \alpha - \tan \beta}{1 + \tan \alpha \tan \beta}$$

VALUES OF TRIGONOMETRIC FUNCTIONS RELATED TO HALF-ANGLE TANGENTS

$$\tan \frac{\alpha}{2} = t$$

$$\cos \alpha = \frac{1 - t^2}{1 + t^2}$$

$$\sin \alpha = \frac{2t}{1 + t^2}$$

$$\tan \alpha = \frac{2t}{1 - t^2}$$

RELATIONS BETWEEN SIDES AND ANGLE OF ANY TRIANGLE

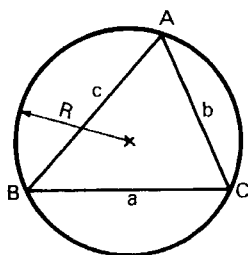

$$\hat{A} + \hat{B} + \hat{C} = \pi$$

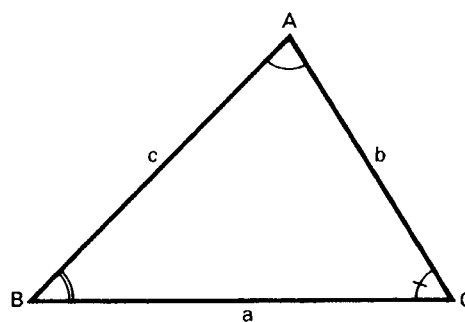



$$a^2 = b^2 + c^2 - 2bc \cos \hat{A}$$

$$b^2 = c^2 + a^2 - 2ca \cos \hat{B}$$

$$c^2 = a^2 + b^2 - 2ab \cos \hat{C}$$

$$\frac{a}{\sin \hat{A}} = \frac{b}{\sin \hat{B}} = \frac{c}{\sin \hat{C}} = 2R$$

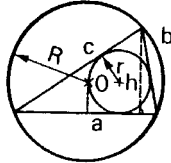
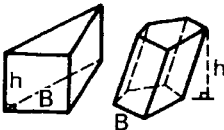
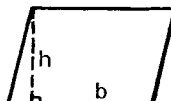
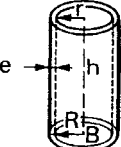
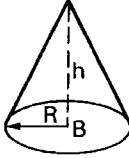
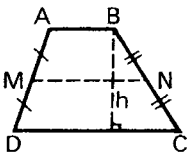
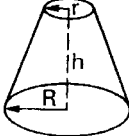
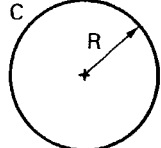
GEOMETRY FORMULAS FOR AREAS AND VOLUMES

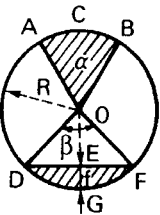
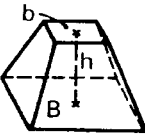
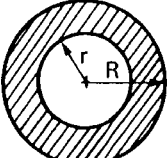
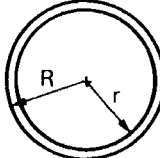
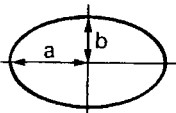
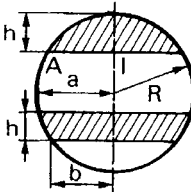
Area	Volume
 <p>Triangle</p> $p = \frac{a+b+c}{2}$ $S = \frac{ah}{2} = \frac{abc}{4R} = pr$	 <p>Regular or oblique prism</p> $V = Bh$
 <p>Parallelogram</p> $S = bh$	 <p>Right cylinder</p> $V = \pi R^2 h = Bh$ <p>Hollow cylinder</p> $V = \pi(R^2 - r^2)h = \pi(R+r)eh$
<p>Square: $S = a^2$ Rectangle: $S = ab$</p>	 <p>Right cone</p> $V = \frac{\pi R^2 h}{3}$
 <p>Trapezoid</p> $S = \frac{AB+CD}{2} h = MN \cdot h$	 <p>Truncated right cone</p> $V = \frac{\pi h}{3} (R^2 + r^2 + Rr)$
 <p>Circle</p> $C = 2\pi R = \pi D$ $S = \pi R^2 = \frac{\pi D^2}{4} = \frac{C^2}{4\pi}$	 <p>Pyramid</p> $V = \frac{1}{3} Bh$
 <p>Sector of a circle</p> $S = \frac{\text{arc } ABC \cdot R}{2} = \frac{\pi R^2 \alpha}{360}$ <p>(α is the number of degrees of arc ACB)</p> <p>Segment of a circle</p> $S = \frac{\pi R^2 \beta}{360} - \frac{DF}{2} (R - f)$	 <p>Truncated pyramid with parallel bases</p> $V = \frac{1}{3} h(B + b + \sqrt{Bb})$
 <p>Annulus</p> $S = \frac{\pi}{4} (D^2 - d^2) = \pi (R^2 - r^2)$ $= \frac{\pi}{4} (D+d)(D-d)$ $= \pi (R+r)(R-r)$	 <p>Sphere $S = 4\pi R^2 = \pi D^2$</p> $V = \frac{4}{3} \pi R^3 = 4,189 R^3$ <p>Hollow sphere</p> $V = \frac{4}{3} \pi (R^3 - r^3)$
 <p>Ellipse</p> <p>a = semimajor axis b = semiminor axis</p> $S = \pi ab$	 <p>Spherical segment with one base</p> $1^\circ) V = \frac{1}{6} \pi h (h^2 + 3\overline{AI}^2)$ $2^\circ) V = \frac{1}{3} \pi h^2 (3R - h)$ <p>Spherical segment with two bases</p> $V = \frac{1}{6} \pi h (3a^2 + 3b^2 + h^2)$

INERTIA OF PLANE SURFACE

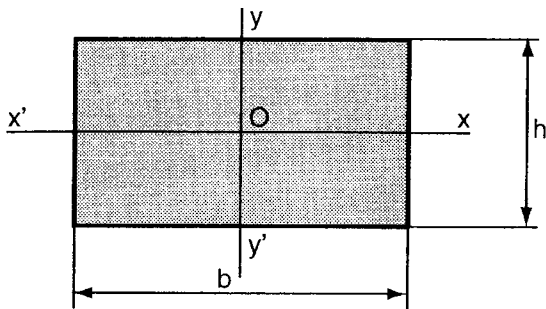

$$I_{xx'} = \frac{bh^3}{12} \quad I_{yy'} = \frac{hb^3}{12}$$

$$I_0 = \frac{bh}{12} (b^2 + h^2)$$

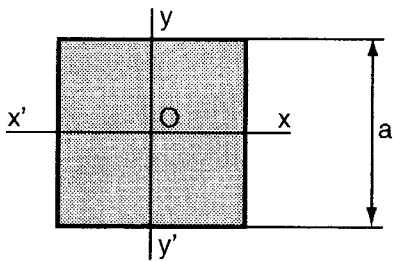

$$I_{xx'} = I_{yy'} = \frac{a^4}{12}$$

$$I_0 = \frac{a^4}{6}$$

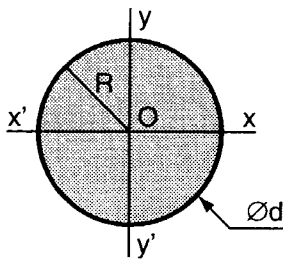

$$I_{xx'} = I_{yy'} = \frac{\pi D^4}{64} = \frac{\pi R^4}{4}$$

$$I_0 = \frac{\pi D^4}{32} = \frac{\pi R^4}{2}$$

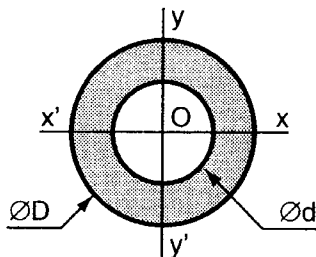

$$I_{xx'} = I_{yy'} = \frac{\pi}{64} (D^4 - d^4)$$

$$I_0 = \frac{\pi}{32} (D^4 - d^4)$$

I_0 = polar moment of inertia.

CONTENT OF HORIZONTAL CYLINDRICAL TANKS
Tank characteristics: Volume: V ; Height: H
Concordance table of fraction of H and fraction of V

Fraction of H	Fraction of V	Fraction of H	Fraction of V	Fraction of H	Fraction of V
0.01	0.0017	0.34	0.2998	0.67	0.7122
0.02	0.0047	0.35	0.3119	0.68	0.7241
0.03	0.0087	0.36	0.3241	0.69	0.7360
0.04	0.0134	0.37	0.3364	0.70	0.7477
0.05	0.0187	0.38	0.3487	0.71	0.7593
0.06	0.0245	0.39	0.3611	0.72	0.7708
0.07	0.0308	0.40	0.3736	0.73	0.7821
0.08	0.0375	0.41	0.3860	0.74	0.7934
0.09	0.0446	0.42	0.3986	0.75	0.8045
0.10	0.0520	0.43	0.4111	0.76	0.8155
0.11	0.0599	0.44	0.4237	0.77	0.8263
0.12	0.0680	0.45	0.4364	0.78	0.8369
0.13	0.0764	0.46	0.4490	0.79	0.8474
0.14	0.0851	0.47	0.4617	0.80	0.8576
0.15	0.0941	0.48	0.4745	0.81	0.8677
0.16	0.1033	0.49	0.4872	0.82	0.8776
0.17	0.1127	0.50	0.5000	0.83	0.8873
0.18	0.1223	0.51	0.5128	0.84	0.8967
0.19	0.1323	0.52	0.5255	0.85	0.9059
0.20	0.1424	0.53	0.5383	0.86	0.9149
0.21	0.1526	0.54	0.5510	0.87	0.9236
0.22	0.1631	0.55	0.5636	0.88	0.9320
0.23	0.1737	0.56	0.5763	0.89	0.9401
0.24	0.1845	0.57	0.5889	0.90	0.9480
0.25	0.1955	0.58	0.6014	0.91	0.9554
0.26	0.2066	0.59	0.6140	0.92	0.9625
0.27	0.2179	0.60	0.6264	0.93	0.9692
0.28	0.2292	0.61	0.6389	0.94	0.9755
0.29	0.2407	0.62	0.6513	0.95	0.9813
0.30	0.2523	0.63	0.6636	0.96	0.9866
0.31	0.2640	0.64	0.6759	0.97	0.9913
0.32	0.2759	0.65	0.6881	0.98	0.9952
0.33	0.2878	0.66	0.7002	0.99	0.9983

Example: Consider a tank of volume $V = 12\ 000$ l and height $H = 2$ m. Measurements show a liquid height of 0.20 m in the tank. How much liquid does the tank contain?

Answer: Fraction of height $0.20/2 = 0.10$ corresponding in the table to a volume fraction of 0.0520. The content is thus: $0.0520 \times 12\ 000 = 624$ liters.

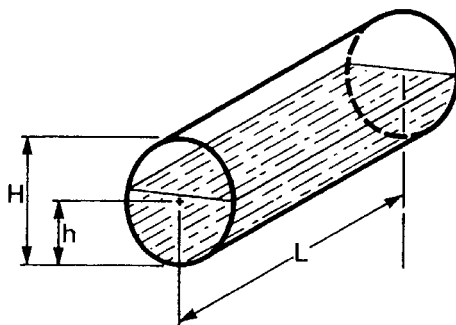

$V =$ total volume:

$$V = \frac{\pi H^2}{4} L$$

$$\text{Fraction of } H = \frac{h}{H}$$

$h =$ liquid height

MECHANICS AND STRENGTH OF MATERIALS

Moment of a force about a point. Moment of a torque

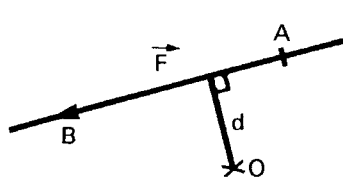

$$M_0^t \vec{F} = Fd$$

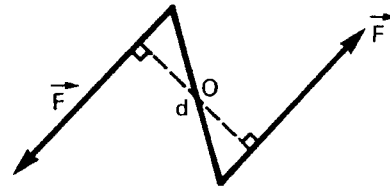

$$M_0^t C = Fd$$

(M_0^t in newtons.meter, F in newtons and d in meters)

UNIFORM STRAIGHT LINE MOTION

$$l = l_0 + vt$$

l = distance travelled (m)
 l_0 = initial distance (m)
 v = velocity (m/s)
 t = time (s)

UNIFORMLY-ACCELERATED MOTION

$$l = l_0 + v_0t + \frac{\gamma t^2}{2}$$

l = distance travelled (m)
 l_0 = initial distance (m)
 v_0 = initial velocity (m/s)
 t = time (s)
 γ = acceleration (m/s²)

UNIFORM CIRCULAR MOTION

Angular velocity $\omega = \frac{\alpha}{t}$ or $\alpha = \omega t$ (α : angle of rotation during time t)

Angular velocity as a function of revolutions per minute

$$\omega = \frac{2\pi N}{60} \quad (\omega \text{ in radians per second and } N \text{ in revolutions per minute)}$$

Circumferential velocity

$$v \text{ (m/min)} = 2\pi RN \quad \text{or} \quad v \text{ (m/s)} = \omega R = \frac{2\pi RN}{60}$$

(ω in radians per second, R in meters and N in revolutions per minute)

Centripetal acceleration γ_c

$$\gamma_c = \omega^2 R \quad \text{or} \quad \gamma_c = \frac{V^2}{R}$$

(γ_c in meters per second per second, ω in radians per second, R in meters and V in meters per second)

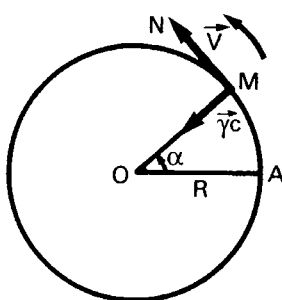

FUNDAMENTAL FORMULA OF DYNAMICS

$$F = m\gamma \quad m = \text{mass, } \gamma = \text{acceleration}$$

(F in newtons, m in kilograms and γ in meters per second per second)

Specific case of gravity $P = m\vec{g}$

\vec{g} = gravitational acceleration
 \vec{g} = about 9.81 m/s²

MECHANICS AND STRENGTH OF MATERIALS (continued)

CENTRIFUGAL FORCE

$$f_c = m\omega^2 R \quad \text{or} \quad f_c = m \frac{V^2}{R}$$

(f_c in newtons, m in kilograms, ω in radians per second, R in meters and V in meters per second)

WORK OF A FORCE

Constant force in quantity and direction displacing its point of application

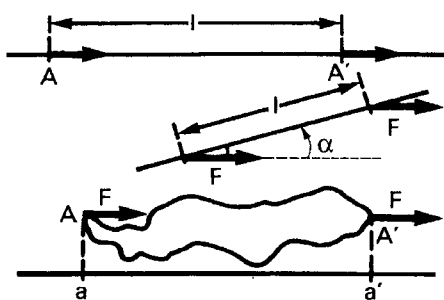

1. on its action line $T = Fl$
 2. on an oblique line to its action line $T = Fl \cos \alpha$
 3. on a curve in its plane $T = Faa'$
- (T in joules, F in newtons and l in meters)

Constant force moving tangentially to a circle

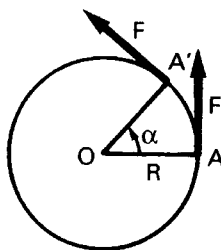

$$T = FR\alpha = M_0^t F\alpha$$

for one rotation $T = 2\pi RF$

(T in joules, F in newtons, R in meters, α in radians and M_0^t in meter Newtons)

WORK OF A TORQUE

Torque rotating about an axis perpendicular to its plane

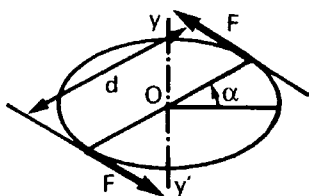

$$T = Fd\alpha = M_0^t C\alpha$$

for one rotation $T = 2\pi M_0^t C = 2\pi Fd$

(T in joules, F in newtons, d in meters, α in radians and M_0^t in meter Newtons)

POWER

Work produced per unit time $P = \frac{T}{t}$ (P in watts, T in joules and t in seconds)

Power of a torque rotating at constant speed ω

$$P = M_0^t C \omega \quad \text{or} \quad P = Fd\omega = Fd \frac{2\pi N}{60}$$

(P in watts, M_0^t in meter Newtons, ω in radians per second, F in newtons, d in meters and N in revolution per minute)

MECHANICS AND STRENGTH OF MATERIALS (continued)

KINETIC ENERGY

$$W = \frac{1}{2} mv^2$$

(*W* in joules, *m* in kilograms and *v* in meters per second)

STRENGTH OF MATERIALS

Tension and compression

Stress:
$$n = \frac{N}{S} 10^{-6}$$

n = stress (MPa)

N = tensile or compressive force (N)

S = cross-sectional area (m²)

Hooke's law:

$$n = E \frac{\Delta \ell}{\ell}$$

E = Young's modulus or longitudinal elastic modulus: approximately 200 000 to 220 000 MPa for steel

$\left. \begin{array}{l} \Delta \ell = \text{elongation} \\ \ell = \text{length} \end{array} \right\}$ expressed in the same units

Torsion

Torsional moment: $M_t = 2Fr$ (M_t in meter Newtons, *F* in newtons and *r* in meters)

Unit torsion $\theta = \frac{\alpha}{\ell}$ $\frac{\alpha}{\ell} = \frac{M_t}{Gl_0}$

Hooke's law: $t_{\max} = Gr\theta$

$$t_{\max} = \frac{M_t}{\frac{l_0}{r}}$$

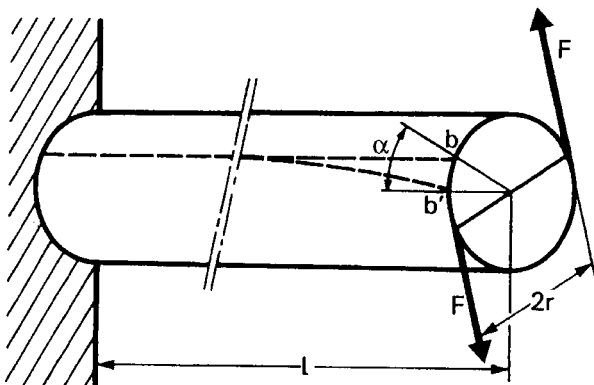

- θ = unit torsion (rad/m)
- α = angle of rotation (rad)
- ℓ = length (m)
- t* = torsional or tangential shear stress (MPa)
- G* = transverse elastic modulus:
 $G = 0.4 \times E$ (Young's modulus)
 $G = 80\,000$ MPa for steel
- r* = radius of cylinder (m)
- l_0 = polar moment of inertia

ELECTRICITY

Direct current

CURRENT: I

Unit: Ampere (A)

Constant current which, maintained in two straight parallel conductors of infinite length and negligible circular cross-sectional area, and placed one meter apart in a vacuum, produces a force of $2 \cdot 10^{-7}$ newtons per meter of length between these conductors.

QUANTITY OF ELECTRICITY: Q

Unit: Coulomb (C)

Quantity of electricity transmitted in one second by a current of one ampere.

Practical unit: ampere-hour (Ah)

Quantity of electricity transmitted in one hour by a current of one ampere (1 Ah = 3600 C)

$$Q \text{ (Ah)} = I \text{ (A)} t \text{ (h)}$$

POTENTIAL DIFFERENCE (VOLTAGE): U

Unit: Volt (V)

Potential difference between two points of conducting wire carrying a constant current of one ampere when the power dissipated between these points is one watt.

RESISTANCE: R

Unit: Ohm (Ω)

Resistance between two points of a conducting wire when a potential difference of one volt, applied between these two points, produces a current of one ampere in the conductor, the conductor not being a source of any electromotive force.

Resistivity: ρ ($\Omega/\text{m}/\text{mm}^2$) at 15°C

Resistance of a wire one meter long with a cross-sectional area of one square millimeter

	$\rho(\Omega/\text{m per mm}^2)$		$\rho(\Omega/\text{m per mm}^2)$
Copper	0.017 – 0.0175	Iron	0.11
Silver	0.016 – 0.018	Steel	0.10 – 0.25
Aluminium	0.229 – 0.0175	Nickel/silver (Cu 60%, Zn 20%, Ni 20%)	0.36 – 0.39

$$R = \rho \frac{\ell}{S} \quad \ell: \text{length of conductor (m)} ; S: \text{cross-sectional area of conductor (mm}^2\text{)}$$

TEMPERATURE COEFFICIENT OF A RESISTANCE AND RESISTIVITY

$$R_t = R_0 (1 + \alpha t) \quad \rho_t = \rho_0 (1 + \alpha t)$$

R_t, ρ_t = resistance, resistivity at $t^\circ\text{C}$

R_0, ρ_0 = resistance, resistivity at 0°C

α = temperature coefficient at 15°C

	α		α
Copper	$3.93 \cdot 10^{-3}$	Iron	$4.7 \cdot 10^{-3}$
Silver	$3.6 \cdot 10^{-3}$	Steel	$5 \cdot 10^{-3}$
Aluminium	$3.9 \cdot 10^{-3}$	Nickel/silver (60%, Zn 20%, Ni 20%)	$3 \cdot 10^{-4}$

ELECTRICITY

Direct current (continued)

RESISTANCE CONNECTIONS

1) Connection in series:

$$R = R_1 + R_2 + R_3 \dots$$

$$U = U_1 + U_2 + U_3 \dots \quad I \text{ constant}$$

2) Connection in parallel:

$$\frac{1}{R} = \frac{1}{R_1} + \frac{1}{R_2} + \frac{1}{R_3} \dots \quad U \text{ constant}$$

$$I = I_1 + I_2 + I_3 \dots$$

For two resistances in parallel:

$$R = \frac{R_1 R_2}{R_1 + R_2} \quad I_1 = I \frac{R_2}{R_1 + R_2} \quad I_2 = I \frac{R_1}{R_1 + R_2}$$

OHM'S LAW

$$U = RI \quad I = \frac{U}{R} \quad R = \frac{U}{I} \quad R (\Omega), I (A), U (V)$$

ELECTRICAL ENERGY (W) OR QUANTITY OF HEAT: Q

Unit: joule (J)

Electrical energy generated each second by a current of one ampere flowing through a resistance of one ohm.

$$W = R I^2 t \quad W = U I t$$

$$(J) \quad (\Omega) (A) (s) \quad (J) \quad (V) (A) (s)$$

Non SI units:

1) Watt-hour (Wh)

Energy expended in one hour by a power of one watt

$$W = R I^2 t \quad 1 \text{ Wh} = 3600 \text{ J}$$

$$(\text{Wh}) \quad (\Omega) (A) (h)$$

2) Calorie (cal)

$$Q = 0.24 R I^2 t \quad 1 \text{ cal} = 4.1855 \text{ J} \quad 1 \text{ J} = 0.2389 \text{ cal}$$

$$(\text{cal}) \quad (\Omega) (A) (h)$$

4.1855 is an experimental value.

ELECTRICAL POWER (P): P

Unit: Watt (W)

Power of one joule per second

$$P = R I^2 \quad P = U I \quad P = \frac{U^2}{R}$$

$$(W) \quad (\Omega) (A) \quad (W) \quad (V) (A) \quad (W) \quad (V) (\Omega)$$

ELECTRICITY

Alternating current

Voltage-current

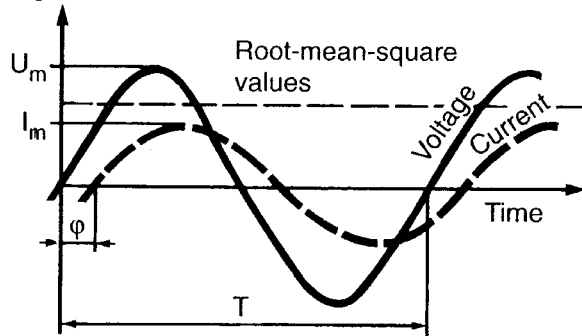

$$\text{Period } T = \frac{1}{F}$$

$$\text{Frequency } F = \frac{1}{T} \text{ (Hz)}$$

$$\text{Angular frequency } \omega = 2\pi F \text{ (rad/s)}$$

Instantaneous values:

$$u = U_m \cos \omega t$$

$$i = I_m \cos (\omega t - \varphi)$$

φ = angle of phase difference between current and voltage

Root-mean-square values (rms values):

$$U = \frac{U_m}{\sqrt{2}} \quad I = \frac{I_m}{\sqrt{2}}$$

Power:

- 1) Applied power
- 2) Active power
- 3) Reactive power

$$S = UI \quad \text{in volt-ampere (VA)}$$

$$P = UI \cos \varphi \quad \text{in watts (W)}$$

$$Q = UI \sin \varphi \quad \text{in reactive volt-amperes (VAR)}$$

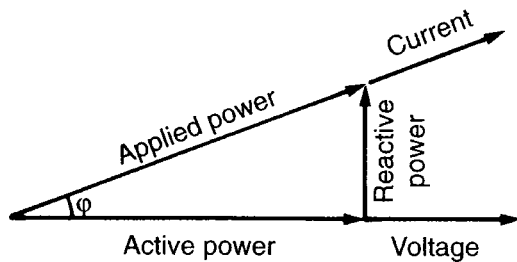

$$S^2 = P^2 + Q^2$$

$$\tan \varphi = \frac{Q}{P}$$

$$\cos \varphi = \frac{P}{S} \text{ (power factor)}$$

THREE-PHASE SYSTEM

Phases windings (formulas valid with same load for all 3 phases)

Star connection

$$U_v = 1.73 U_p$$

$$I = I_p$$

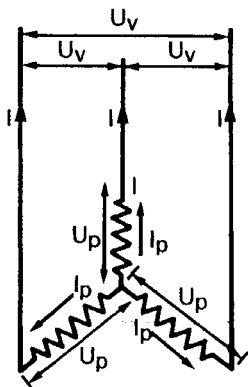

1) Applied power

2) Active power

3) Reactive power

Mesh or Delta connection

$$U_v = U_p$$

$$I = 1.73 I_p$$

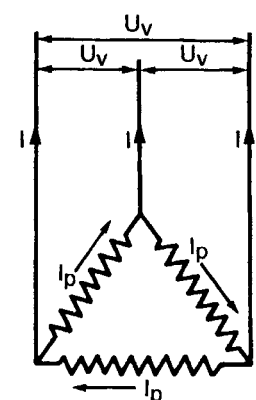

$$S = UI \text{ (VA)}$$

$$P = 1.73 U_v I \cos \varphi \text{ (W)}$$

$$= 3 U_p I_p \cos \varphi \text{ (W)}$$

$$Q = \sqrt{S^2 - P^2}$$

$$= 1.73 U_v I \sin \varphi \text{ (VAR)}$$

$$= 3 U_p I_p \sin \varphi \text{ (VAR)}$$

where:

U_v = voltage in volts between two conductors of the three-phase winding

U_p = voltage for each phase

I = current in amperes through each conductor of the three-phase winding

I_v = current in each phase

φ = phase difference between current and voltage

ELECTRICITY

Alternating current, three-phase system (continued)

Capacitance: C

Unit: farad (F), a capacitance of one farad requires one coulomb of electricity to raise its potential one volt.

$$1 \text{ farad} = \frac{1 \text{ Coulomb}}{1 \text{ volt}} \quad C = \frac{Q}{U}$$

Connections of capacitors (or condensers)

Capacitors in parallel:

$$C = C_1 + C_2 + C_3 + \dots$$

Capacitors in series:

$$\frac{1}{C} = \frac{1}{C_1} + \frac{1}{C_2} + \frac{1}{C_3} + \dots \quad \text{for 2 capacitors: } C = \frac{C_1 \cdot C_2}{C_1 + C_2}$$

Permissible current through conductors

Nominal cross-sectional area (mm ²)	Current Temperature rise = 45°C		
	Numbers of conductors		
	2	3	4
	Current (A)		
2	20	17	15
3	27	22.5	21
5	35	31	28
10	53	47	44
16	66	60	55
25	88	81	70
40	110	103	88
50	130	123	105
75	167	154	132
95	192	184	155

For temperature rises different from 45°C multiply the currents opposite by the following coefficients:	
Temperature rise	Coefficient
20	0.67
25	0.75
30	0.82
35	0.88
40	0.94
45	1
50	1.05
55	1.10
60	1.15

PRINCIPAL CHEMICAL SYMBOLS, ATOMIC NUMBERS AND WEIGHTS

Name	Symbol	Atomic number	Atomic weight	Name	Symbol	Atomic number	Atomic weight
Aluminium	Al	13	27.0	Mercury	Hg	80	200.6
Antimony	Sb	51	122.0	Molybdenum	Mo	42	96.0
Argon	A	18	40.0	Neon	Ne	10	20.0
Arsenic	As	33	75.0	Nickel	Ni	28	58.7
Barium	Ba	56	137.0	Nitrogen	N	7	14.0
Bismuth	Bi	83	209.0	Oxygen	O	8	16.0
Boron	B	5	11.0	Phosphorus	P	15	31.0
Bromine	Br	35	80.0	Platinum	Pt	78	195.0
Cadmium	Cd	48	112.0	Plutonium	Pu	94	242.0
Calcium	Ca	20	40.0	Potassium	K	19	39.0
Carbon	C	6	12.0	Radium	Ra	88	226.0
Chlorine	Cl	17	35.5	Selenium	Se	34	79.0
Chromium	Cr	24	52.0	Silicon	Si	14	28.0
Cobalt	Co	27	59.0	Silver	Ag	47	108.0
Copper	Cu	29	63.5	Sodium	Na	11	23.0
Fluorine	F	9	19.0	Strontium	Sr	38	87.6
Gold	Au	79	197.0	Sulfur	S	16	32.0
Helium	He	2	4.0	Tin	Sn	50	119.0
Hydrogen	H	1	1.0	Titanium	Ti	22	48.0
Iodine	I	53	127.0	Tungsten	W	74	184.0
Iron	Fe	26	56.0	Uranium	U	92	238.0
Lead	Pb	82	207.0	Vanadium	V	23	51.0
Lithium	Li	3	7.0	Xenon	Xe	54	131.3
Magnesium	Mg	12	24.0	Zinc	Zn	30	65.4
Manganese	Mn	25	55.0	Zirconium	Zr	40	91.0

SPECIFIC GRAVITY OF VARIOUS MATERIALS AND FLUIDS

Name	Specific gravity	Name	Specific gravity
Rock:		Materials:	
Dry sand	2.6	Baryte (barium sulfate)	4.2 to 4.3
Gypsum	2.3 to 2.37	Compact brick	2.2
Granite	2.4 to 3.0	Compact clay	2.1
Hard limestone	2.4 to 2.7	Concrete	2.25
Marble	2.5 to 2.9	Glass	2.53
Medium-hard limestone	1.9 to 2.3	Portland cement (powder)	3.0 to 3.3
Quartzite	2.2 to 2.8	Portland cement slurry	1.8 to 2.0
Rock salt	2.16	Walnut shells	1.3
Sandstone	1.9 to 2.6		
Liquids (at 25°C):		Gas (at 10°C and 760 mmHg in relation to air):	
Acetone	0.791	Air	1
Benzene	0.878	Isobutane	2.067
Carbon tetrachloride	1.595	<i>n</i> -butane	2.0854
Chloroform	1.482	Carbon dioxide	1.529
Ether	0.714	Carbon monoxide	0.9671
Ethyl alcohol	0.816	Ethane	1.0493
Glycerin	1.260	Ethylene	0.9749
Methyl alcohol	0.792	hydrogen	0.06952
Trichloroethylene	1.455	Hydrogen sulfide	1.19
Water at 4°C	1	Methane	0.5544
		Oxygen	1.10527
		Propane	1.554

PHYSICAL PROPERTIES OF METALS

Name	Symbol	Specific gravity	Melting point (°C)	Brinell hardness	Mohs scale
Aluminium	Al	2.70	660	16	2.5
Antimony	Sb	6.70	631	–	3.2
Bismuth	Bi	9.75	271	–	2.5
Cadmium	Cd	8.65	321	23	2
Chromium	Cr	7.19	1890	70-130	9
Cobalt	Co	8.90	1495	124	–
Copper	Cu	8.94	1083	–	2.5
Gold	Au	19.32	1063	–	2.5
Iron	Fe	7.88	1535	77	4.5
Lead	Pb	11.34	327	4	1.5
Magnesium	Mg	1.74	651	29	2
Manganese	Mn	7.20	1260	–	5
Mercury	Hg	13.55	– 39	–	–
Molybdenum	Mo	10.20	2620	150-200	–
Nickel	Ni	8.90	1455	110-300	–
Platinum	Pt	21.45	1774	64	4.3
Silver	Ag	10.50	961	–	2.5-7
Tin	Sn	7.30	232	–	1.7
Titanium	Ti	4.50	1800	–	–
Tungsten	W	19.30	3370	350	–
Vanadium	V	5.96	1710	–	–
Zinc	Zn	7.14	419	–	2.5

STRATIGRAPHIC SCALE

Era	Period	Formations	Era	Period	Formations	Era	Period	Formations
Quaternary (Psychozoic)	Holocene (Neolithic) Pleistocene (Paleolithic)	Flandrian Tyrrhenian Sicilian	Secondary (Mesozoic)	Upper Cretaceous	Danian Senonian Turonian Cenomanian	Primary (Paleozoic)	Permian	Zechstein or Thuringian Saxonian Autunian
	Pliocene	Calabrian (Villafranchian) Astian Plaisancian		Lower Cretaceous (Eocretaceous)	Albian Aptian Barremian (Urgonian) Hauterivian Valanginian		Carboniferous	Coal form. (Stephanian) (Vesphalian) Dinantian (Culm)
	Miocene	Saphelian (Pontian) Vindobonian Burdigalian		Upper Jurassic (Malm)	(Purbeckian) Portlandian (Tithonic) Kimmeridgian Sequnian Rauracian Argovian Oxfordian Calloviaian		Devonian	Fammennian Frasnian Givetian Eifelian Coblenician Gedinnian Downtonian
Tertiary (Cenozoic)	Oligocene	Aquitanian Chattian Stampian Sannoisian	Secondary (Mesozoic)	Middle Jurassic (Dogger)	Bathonian Bajocian	Primary (Paleozoic)	Silurian	Gothlandian Ordovician
	Eocene	Ludian Bartonian Lutetian Ypresian Sparnacian Thanetian Montian		Lower Jurassic (Lias)	Aalenian Toarcian Charmouthian Sinemurian Hettangian Rhetian		Cambrian	Potsdamian Acadian Georgian
				Trias	Keuper Muschelkalk Bunter		Precambrian (Algonkian)	
							Archean	

BUOYANCY FACTOR (Steel specific gravity = 7.85)

Mud density			Factor k	Mud density			Factor k
(kg/l)	(lb/gal)	(lb/ft ³)		(kg/l)	(lb/gal)	(lb/ft ³)	
1.00	8.35	62.4	0.873	1.62	13.52	101.1	0.794
1.02	8.51	63.7	0.870	1.64	13.69	102.4	0.791
1.04	8.68	64.9	0.868	1.66	13.85	103.6	0.789
1.06	8.85	66.2	0.865	1.68	14.02	104.9	0.786
1.08	9.01	67.4	0.862	1.70	14.19	106.1	0.783
1.10	9.18	68.7	0.860	1.72	14.35	107.4	0.781
1.12	9.35	69.9	0.857	1.74	14.52	108.6	0.778
1.14	9.51	71.2	0.855	1.76	14.69	109.9	0.776
1.16	9.68	72.4	0.852	1.78	14.85	111.1	0.773
1.18	9.85	73.7	0.850	1.80	15.02	112.4	0.771
1.20	10.01	74.9	0.847	1.82	15.19	113.6	0.768
1.22	10.18	76.2	0.845	1.84	15.36	114.9	0.766
1.24	10.35	77.4	0.842	1.86	15.52	116.1	0.763
1.26	10.51	78.7	0.839	1.88	15.69	117.4	0.761
1.28	10.68	79.9	0.837	1.90	15.86	118.6	0.758
1.30	10.85	81.2	0.834	1.92	16.02	119.9	0.755
1.32	11.02	82.4	0.832	1.94	16.19	121.1	0.753
1.34	11.18	83.7	0.829	1.96	16.36	122.4	0.750
1.36	11.35	84.9	0.827	1.98	16.52	123.6	0.748
1.38	11.52	86.2	0.824	2.00	16.69	124.9	0.745
1.40	11.68	87.4	0.822	2.02	16.86	126.1	0.743
1.42	11.85	88.6	0.819	2.04	17.02	127.4	0.740
1.44	12.02	89.9	0.817	2.06	17.19	128.6	0.738
1.46	12.18	91.1	0.814	2.08	17.36	129.8	0.735
1.48	12.35	92.4	0.811	2.10	17.52	131.1	0.732
1.50	12.52	93.6	0.809	2.12	17.69	132.3	0.730
1.52	12.68	94.9	0.806	2.14	17.86	133.6	0.727
1.54	12.85	96.1	0.804	2.16	18.03	134.8	0.725
1.56	13.02	97.4	0.801	2.18	18.19	136.1	0.722
1.58	13.19	98.6	0.799	2.20	18.36	137.3	0.720
1.60	13.35	99.9	0.796	2.22	18.53	138.6	0.717

$$k = 1 - \frac{\text{Mud density}}{\text{Steel density}}$$

Calculation of apparent string weight in mud

$$\text{Apparent weight} = \text{Real weight} - \text{Buoyancy}$$

$$\text{Buoyancy} = \frac{\text{Real weight} \times \text{Mud density}}{\text{Steel density}}$$

hence:

$$\text{Apparent weight} = \text{Real weight} \left[\frac{\text{Steel density} - \text{Mud density}}{\text{Steel density}} \right]$$

$$\text{Apparent weight} = \text{Real weight} \times \text{Buoyancy factor}$$

Example: Steel weight of a string = 125 t

Mud density = 1.18 kg/l

Apparent weight of string = 125 × 0.849 = 106.1 t

B

drill string standards

API steel grade and properties (API Spec 5D, 3 rd edition, Aug. 1, 1992)(API Spec.7, 38 th edition, Apr. 1, 1994).....	B1
API drill pipe list and body and upset geometry (API Spec 5D, 3 rd edition, August 1, 1992).....	B2
Upset tubing for small-diameter work string (API Standard 5A and Spec 7)(Grade N-80).....	B3
Classification of used drill pipe (API RP 7G, 15 th edition January 1, 1995)(All sizes, weight and grades).....	B4
Inspection standards. Zones and color code identification (API RP 7G, 15 th edition January 1, 1995).....	B5
Recommended practice for mill slot and groove method of drill string identification (API RP 7G, 15 th edition January 1, 1995).....	B6-B7
Geometric characteristics of drill pipes (New pipe bodies and tool joints).....	B8-B12
New (N), premium class (P) and class2 (2) drill pipe, torsional and tensile data (API RP 7G, 15 th edition, January 1, 1995).....	B13-B15
New (N), premium class (P) and class2 (2) drill pipe, collapse and burst pressure data (API RP 7G, 15 th edition January 1, 1995).....	B16-B18

Recommended minimum OD* and make-up torque of weld-on type tool joints based on the torsional strength of box and drill pipe (API RP 7G, 15 th edition, January 1, 1995).....	B19-B23
Thread dimensions of rotary shouldered connections (API Spec 38 th edition, April 1, 1994).....	B24
Shouldered connections.....	B25
Dimensions of obsolete shouldered connections (API Spec 7, Appendix I).....	B26
API threads forms and dimensions (API Spec 7, 38 th edition, April 1, 1994).....	B27
Characteristics of some non_API tool joints threads.....	B28-B29
Rotary shouldered connection interchange list.....	B30-B31
Cylindrical drill collars. Dimensions and threads (API Spec7).....	B32
Ideal drill collar range.....	B33
Weight of drill collar (Kg/m).....	B34
Polar modulus of drill collars (in ³ -mm ³).....	B35
Drill-collar Assembly. Rigidity <i>R</i>	B36
Stress-relief features for drill collar connections (API Spec 7).....	B37
Large-diameter drill collars from 8¾ to 11¼ inches. Shoulder modifications for low-torque connections. Dimensions of low-torque shouldered.....	B38
Spiral drill collars (Drilco).....	B39
Drill collar slip and elevator recess elevator bore dimensions (API RP 7G, 15 th edition, January 1, 1995)....	B40
Recommended make-up torque for rotary shouldered drill collar connections (API RP 7G, 15 th edition, January 1, 1995).....	B41-B46

Heavy wall drill pipes (Drilco, Division of Smith International, Inc.).....	B47-B48
Kellys (API Spec 7, 38 th edition, April 1, 1994).....	B49
Strength of Kellys (API RP 7G, 15 th edition, January 1, 1995).....	B50
Stretch of suspended drill pipe.....	B51
Drill stem design calculations (API RP 7G, 15 th edition, January 1,1995).....	B52-B55
Drill stem design calculations. Calculation examples.....	B56-B59
Critical buckling force (Baker Hughes INTEQ).....	B60

API STEEL GRADES AND PROPERTIES
(API Spec 5D, 3rd edition, August 1, 1992)
(API Spec 7, 38th edition, April 1, 1994)

	Yield strength				Minimum tensile strength		
	Minimum		Maximum				
	(psi)	(MPa)	(psi)	(MPa)	(psi)	(MPa)	
Drill pipe							
Steel grade							
E75	75 000	517	105 000	724	100 000	689	Box minimum hardness (Brinell)
X95	95 000	655	125 000	862	105 000	724	
G105	105 000	724	135 000	931	115 000	793	
S135	135 000	931	165 000	1138	145 000	1000	
Tool joints	120 000	827	–	–	140 000	965	285
Drill collars and cross-over sub							
Outside diameter (in)							
3 1/8 to 6 7/8	110 000	758	–	–	140 000	965	285
7 to 11	100 000	689	–	–	135 000	931	285

Mechanical properties and tests
New non magnetic drill collars

Drill collar OD range	Stainless steels				Beryllium copper			
	Minimum yield strength		Minimum tensile strength		Minimum yield strength		Minimum tensile strength	
	(psi)	(MPa)	(psi)	(MPa)	(psi)	(MPa)	(psi)	(MPa)
(in)								
3 1/2 to 6 7/8	110 000	758	120 000	827	110 000	758	140 000	965
7 to 11	100 000	689	110 000	758	100 000	689	135 000	931

API DRILL PIPE LIST AND BODY AND UPSET GEOMETRY (API Spec 5D, 3rd edition, August 1, 1992)

Nominal diameter		Nominal weight	Wall thickness of pipe body	Inside diameter of pipe body	Steel grade	Upset					
						IU		EU		IEU	
(in)	(mm)	(lb/ft)	(mm)	(mm)		OD (mm)	ID (mm)	OD (mm)	ID (mm)	OD (mm)	ID (mm)
2 3/8	60.3	6.65	7.11	46.1	E X-G-S			67.5 67.5	46.1 39.7		
2 7/8	73.0	10.40	9.19	54.6	E X-G-S	73.0 73.0	33.3 41.4	81.8 82.6	54.6 49.2		
3 1/2	88.9	9.50	6.45	76.0	E	88.9	57.2	97.1	76.0		
3 1/2	88.9	13.30	9.35	70.2	E X-G-S	88.9 88.9	49.2 49.2	97.1 101.6	66.1 63.5		
3 1/2	88.9	15.50	11.40	66.1	E X-G-S	88.9 -	49.2 -	97.1 101.6	66.1 63.5	- 96.0	- 49.2
4	101.6	14.00	8.38	84.8	E X-G-S	101.6 101.6	69.8 66.8	114.3 117.5	84.8 77.8		
4 1/2	114.3	13.75	6.88	100.5	E	114.3	85.7	127.0	100.5		
4 1/2	114.3	16.60	8.56	97.2	E X-G-S	- -		127.0 131.8	97.2 90.5	118.3 118.3	80.2 73.0
4 1/2	114.3	20.00	10.92	92.5	E X-G-S	- -		127.0 131.8	92.5 87.3	121.4 121.4	76.2 71.5
5	127.0	16.25	7.52	112.0	E	127.0	95.2				
5	127.0	19.50	9.19	108.6	E X-G-S			- 146.1	- 100.0	131.8 131.8	93.7 90.5
5	127.0	25.60	12.70	101.6	E X-G-S			- 149.2	- 96.9	131.8 131.8	87.3 84.2
5 1/2	139.7	21.90	9.17	121.4	E X-G-S					141.3 141.3	101.6 96.9
5 1/2	139.7	24.70	10.54	118.6	E X-G-S					141.3 141.3	101.6 96.9
6 5/8	168.3	25.20	8.38	151.5	E					176.0	135.0
6 5/8	168.3	25.20	8.38	151.5	X-G-S					176.0	135.0
6 5/8	168.3	27.70	9.19	149.9	E X-G-S					176.0 176.0	135.0 135.0

mm x 0.0394 = in

UPSET TUBING FOR SMALL-DIAMETER WORK STRINGS (1) (API Standard 5A and Spec 7) (Grade N80)

Outside diameter	Nominal weight	Wall thickness	Weight with tool-joints	Inside diameter		Upset outside diameter	Cross section area	Inside capacity	Volume of steel	Tensile yield strength (2)	Torsional yield strength (2)	Internal pressure (2)	Collapse resistance (2)
				Body (mm)	Upset (mm)								
(in)	(lb/ft)	(mm)	(kg/m)			(mm)	(mm ²)	(l/m)	(l/m)	(10 ³ daN)	(daN.m)	(MPa)	(MPa)
1.050	1.55	3.91	2.20	18.9	17.5	36.5	280	0.280	0.280	15.8	89	141	139
1.315	2.30	4.55	3.36	24.3	21.4	42.8	413	0.464	0.428	23.4	168	131	131
1.660	3.29	5.03	4.77	32.1	22.2	47.6	588	0.810	0.607	33.4	310	115	116
1.900	4.19	5.56	6.10	37.2	23.8	55.5	746	1.085	0.777	42.3	455	111	111

(1) These drill pipes are derived from IEU tubing pipes for welding tool joints with API numbered rotary shouldered connections NC10, NC12, NC13 and NC16. The dimensions specified for upsets do not necessarily agree with the dimensions of the bore and the outside diameter of the finished welded assemblies. The dimensions specified for upsets were selected to accommodate the various bores of the tool joints and to maintain a satisfactory cross-section in the weld zone after final machining of the assembly.

(2) These pipes are generally of N80 steel. The mechanical properties are given for this steel grade.

$$\begin{aligned} \text{mm} \times 0.0394 &= \text{in} & \text{kg/m} \times 0.672 &= \text{lb/ft} & \text{mm}^2 \times 0.00155 &= \text{in}^2 & \text{l/m} \times 0.0805 &= \text{gal/ft} & \text{l/m} \times 0.00192 &= \text{bbl/ft} \\ \text{daN} \times 2.25 &= \text{lb} & \text{daN.m} \times 7.38 &= \text{lb.ft} & \text{bar} \times 14.5 &= \text{psi} \end{aligned}$$

**CLASSIFICATION OF USED DRILL PIPE
(API RP 7G, 15th edition, January 1, 1995)
(All sizes, weights and grades)**

(Nominal dimension is basis for all calculations)

Pipe condition	PREMIUM CLASS Two white bands One center punch mark	CLASS 2 Yellow bands Two center punch marks	CLASS 3 Orange bands Three center punch marks
I EXTERIOR CONDITIONS			
A. OD wear Wall	Remaining wall not less than 80%	Remaining wall not less than 70%	Any imperfections or damages exceeding CLASS 2
B. Dents & mashes	Diameter reduction not over 3% of OD	Diameter reduction not over 4% of OD	
C. Slip area Mechanical damage			
1. Crushing, necking	Diameter reduction not over 3% of OD Depth not to exceed 10% of the average adjacent wall	Diameter reduction not over 4% of OD Depth not to exceed 20% of the average adjacent wall	
2. Cuts, gouges			
D. Stress induced Diameter variations			
1. Stretched	Diameter reduction not over 3% of OD	Diameter reduction not over 4% of OD	
2. String shot	Diameter increase not over 3% of OD	Diameter increase not over 4% of OD	
E. Corrosion, cuts and gouges			
1. Corrosion	Remaining wall not less than 80%	Remaining wall not less than 70%	
2. Cuts and gouges			
Longitudinal	Remaining wall not less than 80%	Remaining wall not less than 70%	
Transverse	Remaining wall not less than 80%	Remaining wall not less than 80%	
F. Cracks	None	None	None
II INTERIOR CONDITIONS			
A. Corrosive pitting Wall	Remaining wall not less than 80% measured from vase of deepest pit	Remaining wall not less than 70% measured from base of deepest pit	
B. Errosion and wear Wall	Remaining wall not less than 80%	Remaining wall not less than 70%	
C. Cracks	None	None	None

INSPECTION STANDARDS

Zones and color code identification (API RP 7G, 15th edition, January 1, 1995)

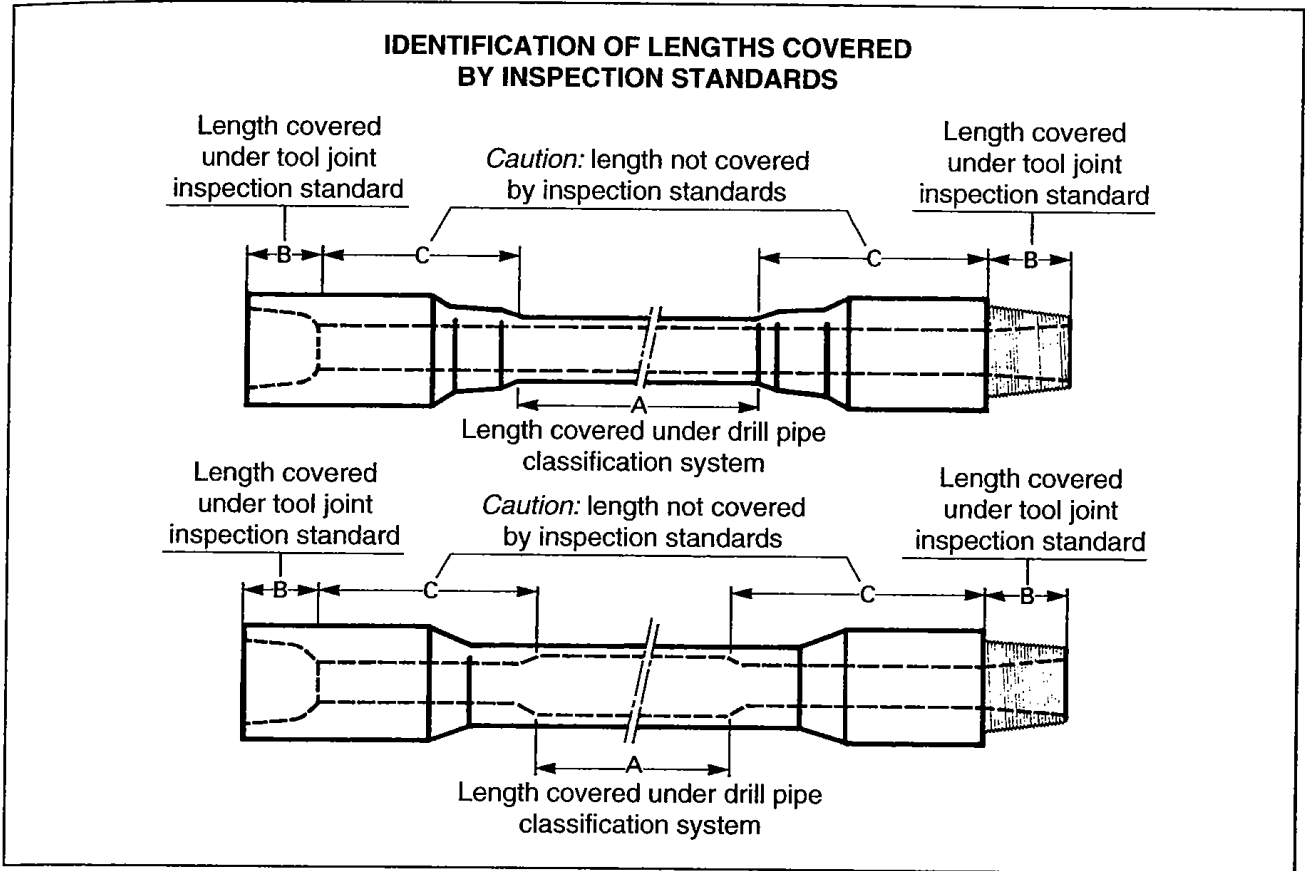

DRILL PIPE AND TOOL JOINT COLOR CODE IDENTIFICATION

The diagram shows a drill pipe with various color-coded bands. Labels include 'Tool joint condition bands', 'Classification paint bands for drill pipe and tool joints', and 'Stencils for permanent marking for classification of drill pipe body'. A stencil number '12691' is visible on the pipe.

Tool joint and drill pipe classification	Number and color of bands
Premium Class	Two white
Class 2	One yellow
Class 3	One orange
Scrap	One red

Tool joint condition	Color of bands
Scrap or shop repairable	Red
Field repairable	Green

**RECOMMENDED PRACTICE
FOR MILL SLOT AND GROOVE METHOD
OF DRILL STRING IDENTIFICATION
(API RP 7G, 15th edition, January 1, 1995)**

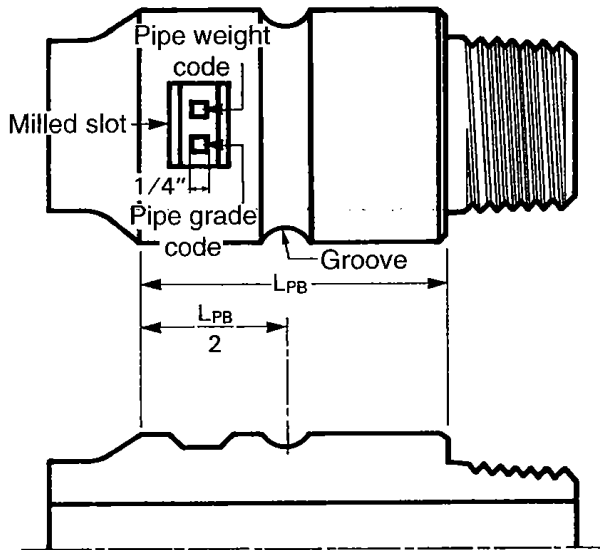

Standard weight high strength drill pipe

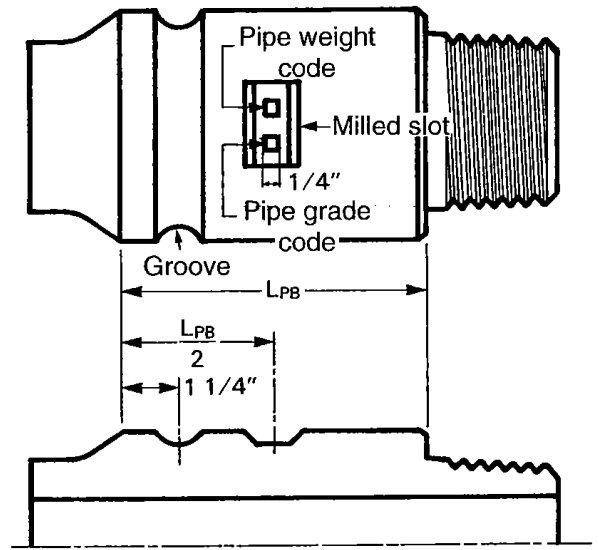

Heavy weight high strength drill pipe

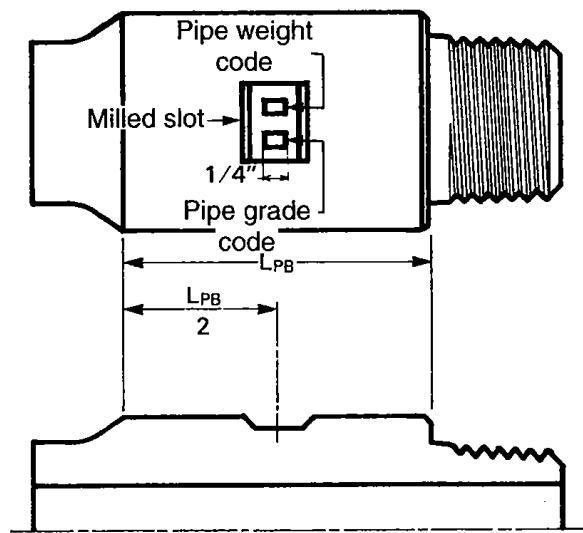

Heavy weight grade E drill pipe

L_{PB} = pin tong space length

**RECOMMENDED PRACTICE
FOR MILL SLOT AND GROOVE METHOD
OF DRILL STRING IDENTIFICATION
(API RP 7G, 15th edition, January 1, 1995)
(continued)**

Drill pipe grade code			
Standard grades		High strength grades	
Grade	Symbol	Grade	Symbol
N-80	N	X-95	X
E	E	G-105	G
C-75	C	S-135	S
Drill pipe weight code			
Size OD (in)	Nominal weight (lb/ft)	Wall thickness (in)	Weight code number
2 3/8	4.85	0.190	1
	6.65*	0.280	2
2 7/8	6.85	0.217	1
	10.40*	0.362	2
3 1/2	9.50	0.254	1
	13.30*	0.368	2
	15.50	0.449	3
4	11.85	0.262	1
	14.00*	0.330	2
	15.70	0.380	3
4 1/2	13.75	0.271	1
	16.60*	0.337	2
	20.00	0.430	3
	22.82	0.500	4
	24.66	0.550	5
	25.50	0.575	6
5	16.25	0.296	1
	19.50*	0.362	2
	25.60	0.500	3
5 1/2	19.20	0.304	1
	21.90*	0.361	2
	24.70	0.415	3
6 5/8	25.20*	0.330	2
	27.70	0.362	3

* Designates standard weight for drill pipe size.

Note: Standard weight grade E drill pipe designated by an asterisk (*) in the drill pipe weight code will have no groove or milled slot for identification.

Grade E heavy weight drill pipe will have a milled slot only, in the center of the tong space.

GEOMETRIC CHARACTERISTICS OF DRILL PIPES (New pipe bodies and tool joints)

Nominal diameter (in)	Nominal weight (lb/ft)	Wall thickness (mm)	ID		Cross-section (mm ²)	Polar moment of inertia (mm ⁴)*	Polar modulus (mm ³)**	Upset and grade		Type of tool joint	Tool joint OD (mm)	Tool joint ID (mm)	Approximate weight including tool joint													
			(in)	(mm)									(kg/m)	(lb/ft)												
2 3/8 (60.33 mm)	4.85	4.83	1.995	50.67	842	653 421	21 662	E	NC26 (IF) WO	85.7	44.5	7.89	5.30													
														EU	OH	7.59	5.10									
														EU	SL-H90	7.29	4.90									
	6.65	7.11	46.11	1.815	1 189	856 775	28 403	E	NC26 (IF) OH	85.7	44.5	10.44	7.02													
														EU	PAC	10.27	6.90									
														IU		10.12	6.80									
2 7/8 (73.03 mm)	6.85	5.51	2.441	62.01	1 169	1 340 977	36 724	E	NC31 (IF) WO	104.8	54.0	11.16	7.50													
														EU	OH	10.86	7.30									
														EU	SL-H90	10.27	6.90									
														EU		10.57	7.10									
														10.40	9.19	54.65	2.151	1 843	1 916 866	52 495	E	NC31 (IF) OH	104.8	54.0	16.21	10.89
	EU		15.78	10.60																						
	IU	XH	16.67	11.20																						
	IU	NC26 PAC	15.48	10.40																						
	IU		15.33	10.30																						
	11.54	11.30	16.82	41.3	41.3	16.82	16.82	S	NC31 (IF) SL-H90	111.1	41.3	17.18	11.54													
														EU		16.22	10.90									
EU															16.22	10.90										
EU															16.22	10.90										
EU															16.22	10.90										
EU															16.22	10.90										

* Polar moment of inertia = $\frac{\pi}{32} (OD^4 - ID^4)$ ** Polar modulus = $\frac{\pi}{16} \left(\frac{OD^4 - ID^4}{OD} \right)$
mm x 0.0394 = in mm² x 0.00155 = in² mm³ x 6.10 10⁻⁶ = in³ mm⁴ x 2.40 10⁻⁶ = in⁴

GEOMETRIC CHARACTERISTICS OF DRILL PIPES (New pipe bodies and tool joints) (continued)

Nominal diameter (in)	Nominal weight (lb/ft)	Wall thickness (mm)	ID		Cross-section (mm ²)	Polar moment of inertia (mm ⁴)*	Polar modulus (mm ³)**	Upset and grade		Type of tool joint	Tool joint OD (mm)	Tool joint ID (mm)	Approximate weight including tool joint		
			(in)	(mm)									(kg/m)	(lb/ft)	
3 1/2 (88.90 mm)	9.50	6.45	2.992	76.00	1 671	2 856 744	64 269	EU	E	NC38 (IF)	120.7	68.3	15.76	10.59	
								EU	E	NC38(WO)	120.7	76.2	15.38	10.33	
	13.30	9.35	70.20	2.764	70.20	2 337	3 747 837	84 316	EU	E	NC38 (IF)	120.7	68.3	20.76	13.95
									EU	E	OH	120.7	68.3	20.76	13.95
									EU	E	XH	120.7	61.9	21.13	14.20
									IU	E	NC31 (SH)	104.8	54.0	20.24	13.60
									EU	X	NC38 (IF)	127.0	65.1	21.75	14.62
									EU	X	SL-H90	120.7	65.1	21.13	14.20
	15.50	11.40	66.10	2.602	66.10	2 776	4 257 912	95 791	EU	G	NC38 (IF)	127.0	61.9	21.89	14.71
									EU	G	SL-H90	120.7	65.1	21.13	14.20
EU									S	NC38 (IF)	127.0	54.0	22.21	14.92	
EU									S	SL-H90	127.0	54.0	22.21	14.92	
EU									S	NC40 (4FH)	136.5	61.9	22.77	15.30	
EU									E	NC38 (IF)	127.0	65.1	24.65	16.56	
EU									X	NC38 (IF)	127.0	61.9	25.05	16.83	
EU									G	NC38 (IF)	127.0	54.0	25.37	17.05	
4 (101.60 mm)	11.85	6.65	3.476	88.30	1 984	4 492 846	88 442	EU	E	NC46 (IF)	152.4	82.6	20.09	13.50	
								EU	E	NC46 (WO)	146.1	87.3	19.79	13.30	
	14.00	8.38	84.84	3.340	84.84	2 454	5 374 730	105 802	IU	E	H90	139.7	71.4	18.10	12.16
									EU	E	NC46 (IF)	152.4	82.6	23.65	15.89
									EU	E	OH	139.7	82.6	22.32	15.00
									IU	E	NC40 (FH)	139.7	71.4	22.39	15.05
									IU	E	SH	117.5	65.1	21.43	14.40
									EU	X	NC46 (IF)	152.4	82.6	24.10	16.19
									IU	X	NC40 (FH)	133.4	68.3	22.74	15.28
									IU	X	H90	139.7	71.4	23.22	15.60

* , ** See notes on page B 8.

mm² x 0.00155 = in² mm³ x 6.10 10⁻⁶ = in³

mm⁴ x 2.40 10⁻⁶ = in⁴

GEOMETRIC CHARACTERISTICS OF DRILL PIPES (New pipe bodies and tool joints) (continued)

Nominal diameter (in)	Nominal weight (lb/ft)	Wall thickness (mm)	ID		Cross-section (mm ²)	Polar moment of inertia (mm ⁴)	Polar modulus (mm ³)	Upset and grade		Type of tool joint	Tool joint OD		Tool joint ID		Approximate weight including tool joint	
			(in)	(mm)							(mm)	(mm)	(kg/m)	(lb/ft)		
4 (101.60 mm)	14.00	8.38	3.340	84.84	2 454	5 374 730	105 802	EU	G	NC46 (IF)	152.4	82.6	24.10	16.19		
								IU	G	NC40(FH) H90	139.7	61.9	23.59	15.85		
								EU	S	NC46 (IF)	152.4	76.2	24.44	16.42		
								IU	S	NC40(FH) H90	139.7	50.8	24.00	16.13		
4 1/2 (114.30 mm)	13.75	6.88	3.958	100.54	2 322	6 725 300	117 678	EU	E	NC50 (IF) NC50 (WO) OH H90	161.9	95.3	22.91	15.39		
								EU	E		155.6	98.4	22.03	14.80		
								EU	E		146.1	100.8	20.98	14.10		
								IU	E		152.4	82.6	22.62	15.20		
								EU	E	NC50 (IF) NC50 (IF) OH	161.9	95.3	26.78	18.00		
								EU	E		168.3	95.3	27.49	18.47		
								EU	E		149.2	95.3	25.45	17.10		
								IEU	E	NC46 (XH) FH H90	158.8	82.6	27.34	18.37		
	16.60	8.56	3.826	97.18	2 844	8 000 523	139 992	IEU	E		152.4	76.2	27.00	18.14		
								IEU	E		152.4	82.6	26.64	17.90		
								IEU	E		152.4	82.6	26.64	17.90		
								IEU	E	NC38 (SH)	127.0	68.3	25.00	16.80		
								EU	X	NC50 (IF) NC50 (IF) NC46 (XH) FH H90	161.9	95.3	27.33	18.36		
								EU	X		168.3	95.3	28.05	18.85		
								IEU	X		158.8	76.2	27.71	18.62		
								IEU	X		152.4	76.2	27.02	18.16		
4 1/2 (114.30 mm)	16.60	8.56	3.826	97.18	2 844	8 000 523	139 992	IEU	X		152.4	82.6	26.79	18.00		
								EU	G	NC50 (IF) NC50 (IF) NC46 (XH) FH H90	161.9	95.3	27.33	18.36		
								EU	G		168.3	95.3	28.05	18.85		
								IEU	G		158.8	76.2	27.71	18.62		
								IEU	G		152.4	76.2	27.02	18.16		
								IEU	G		152.4	82.6	26.79	18.00		
								EU	S	NC50 (IF) NC50 (IF) NC46 (XH) FH H90	161.9	88.9	27.72	18.63		
								EU	S		168.3	88.9	28.44	19.11		
								IEU	S		158.8	69.9	28.02	18.83		
								IEU	S		158.8	63.5	28.31	19.02		
								IEU	S		152.4	76.2	27.02	18.16		

mm x 0.0394 = in mm² x 0.00155 = in² mm³ x 6.10 10⁻⁵ = in³ mm⁴ x 2.40 10⁻⁶ = in⁴

GEOMETRIC CHARACTERISTICS OF DRILL PIPES (New pipe bodies and tool joints) (continued)

Nominal diameter (in)	Nominal weight (lb/ft)	Wall thickness (mm)	ID		Cross-section (mm ²)	Polar moment of inertia (mm ⁴)	Polar modulus (mm ³)	Upset and grade		Type of tool joint	Tool joint OD (mm)	Tool joint ID (mm)	Approximate weight including tool joint										
			(in)	(mm)									(kg/m)	(lb/ft)									
4 1/2 (114.30 mm)	20.00	10.92	3.640	92.46	3 547	9 581 665	167 658	E	NC50 (IF)	161.9	92.1	32.19	21.63	32.19	21.63								
																EU	NC50 (IF)	168.3	92.1	32.91	22.11	32.91	22.11
																IEU	NC50 (IF)	158.8	76.2	32.92	22.12	32.92	22.12
																IEU	NC46 (XH)	152.4	76.2	32.24	21.66	32.24	21.66
																IEU	NC46 (XH)	152.4	76.2	32.24	21.66	32.24	21.66
																IEU	H90	152.4	76.2	32.24	21.66	32.24	21.66
																EU	NC50 (IF)	161.9	88.9	32.88	22.09	32.88	22.09
																EU	NC50 (IF)	168.3	88.9	33.60	22.58	33.60	22.58
																IEU	NC50 (IF)	158.8	69.9	33.66	22.62	33.66	22.62
																IEU	NC46 (XH)	152.4	63.5	33.26	22.35	33.26	22.35
IEU	NC46 (XH)	152.4	82.6	32.29	21.70	32.29	21.70																
5 (127 mm)	19.50	9.19	4.276	108.62	3 401	11 873 714	186 988	E	NC50 (XH)	161.9	95.3	31.06	20.87	31.06	20.87								
																EU	NC50 (XH)	168.3	95.3	31.77	21.35	31.77	21.35
																IEU	NC50 (XH)	177.8	95.3	33.19	22.30	33.19	22.30
																IEU	5 1/2 FH	161.9	88.9	31.84	21.40	31.84	21.40
																IEU	NC50 (XH)	168.3	88.9	32.55	21.87	32.55	21.87
																IEU	NC50 (XH)	177.8	95.3	33.58	22.56	33.58	22.56
																IEU	5 1/2 FH	165.1	82.6	32.55	21.87	32.55	21.87
																IEU	NC50 (XH)	168.3	82.6	32.92	22.12	32.92	22.12
																IEU	NC50 (XH)	177.8	95.3	33.58	22.56	33.58	22.56
																IEU	5 1/2 FH	168.3	69.9	33.57	22.56	33.57	22.56
IEU	NC50 (XH)	184.2	88.9	34.86	23.42	34.86	23.42																
5 (127 mm)	25.60	12.70	4.000	101.60	4 560	15 078 604	237 458	E	NC50 (XH)	161.9	95.3	40.00	26.88	40.00	26.88								
																IEU	NC50 (XH)	168.3	95.3	40.70	27.35	40.70	27.35
																IEU	NC50 (IF)	177.8	95.3	42.12	28.30	42.12	28.30

mm x 0.0394 = in mm² x 0.00155 = in² mm³ x 6.10 10⁻⁵ = in³ mm⁴ x 2.40 10⁻⁶ = in⁴

GEOMETRIC CHARACTERISTICS OF DRILL PIPES (New pipe bodies and tool joints) (continued)

Nominal diameter (in)	Nominal weight (lb/ft)	Wall thickness (mm)	ID		Cross-section (mm ²)	Polar moment of inertia (mm ⁴)	Polar modulus (mm ³)	Upset and grade		Type of tool joint	Tool joint OD (mm)	Tool joint ID (mm)	Approximate weight including tool joint	
			(in)	(mm)				IEU	X				(kg/m)	(lb/ft)
5 (127 mm)	25.60	12.70	4.000	101.60	4 560	15 078 604	237 458	IEU	X	NC50 (XH)	165.1	76.2	41.40	27.82
								IEU	X	NC50 (IF)	168.3	73.2	41.77	28.07
								IEU	X	5 1/2 FH	177.8	88.9	42.48	28.55
5 1/2 (139.70 mm)	21.90	9.17	4.778	121.36	3 760	16 096 385	230 442	IEU	E	FH	177.8	101.6	35.41	23.79
								IEU	X	FH	177.8	95.3	36.33	24.41
								IEU	G	FH	184.2	88.9	37.59	25.26
6 5/8 (168.28 mm)	24.70	10.54	4.670	118.62	4 277	17 955 483	257 058	IEU	S	FH	190.5	76.2	39.25	26.37
								IEU	E	FH	177.8	101.6	39.16	26.31
								IEU	X	FH	184.2	88.9	41.29	27.75
6 5/8 (168.28 mm)	25.20	8.38	5.965	151.52	4 210	26 981 773	320 677	IEU	S	FH	190.5	76.2	42.94	28.85
								IEU	E	FH	203.2	127.0	41.00	27.55
								IEU	X	FH	203.2	127.0	41.00	27.55
6 5/8 (168.28 mm)	27.70	9.19	5.901	149.90	4 593	29 159 551	346 560	IEU	S	FH	215.9	107.9	44.70	30.04
								IEU	E	FH	203.2	127.0	43.76	29.41
								IEU	X	FH	209.6	120.7	45.32	30.45
6 5/8 (168.28 mm)	27.70	9.19	5.901	149.90	4 593	29 159 551	346 560	IEU	G	FH	209.6	120.7	45.32	30.45
								IEU	S	FH	209.6	120.7	45.32	30.45
								IEU	S	FH	215.9	107.9	47.44	31.88

mm x 0.0394 = in mm² x 0.00155 = in² mm³ x 6.10 10⁻⁵ = in³ mm⁴ x 2.40 10⁻⁶ = in⁴

**NEW (N), PREMIUM CLASS (P) AND CLASS 2 (2) DRILL PIPE,
TORSIONAL AND TENSILE DATA
(API RP 7G, 15th edition, January 1, 1995)**

Size OD	Nominal weight	Class	Torsional yield strength ¹												Tensile yield strength																																																																																																																																		
			E			95			105			135			E			95			105			135																																																																																																																									
			(ft.lb)	(daN.m)	(ft.lb)	(daN.m)	(ft.lb)	(daN.m)	(ft.lb)	(daN.m)	(ft.lb)	(daN.m)	(ft.lb)	(daN.m)	(ft.lb)	(daN.m)	(ft.lb)	(daN.m)	(ft.lb)	(daN.m)	(ft.lb)	(daN.m)	(ft.lb)	(daN.m)	(ft.lb)	(daN.m)	(ft.lb)	(daN.m)																																																																																																																					
2 3/8	4.85	N	4 763	645	6 033	817	904	8 574	1 162	97 817	43.5	123 902	55.1	136 944	60.9	176 071	78.3	P	3 725	505	4 719	639	707	6 705	909	76 893	34.2	97 398	43.3	107 650	47.8	138 407	61.5	2	3 224	437	4 083	553	612	5 802	786	66 686	29.6	84 469	37.5	93 360	41.5	120 035	53.3																																																																																																
		N	6 250	847	7 917	1 073	1 186	11 251	1 525	138 214	61.4	175 072	77.8	193 500	86.0	248 786	110.6		P	4 811	652	6 093	826	913	8 659	1 173	107 616	47.8	136 313	60.6	150 662	67.0	193 709		86.1	2	4 130	560	5 232	709	783	7 434	1 007	92 871	41.3	117 636	52.3	130 019	57.8	167 167	74.3																																																																																														
		N	8 083	1 095	10 238	1 387	1 533	14 549	1 971	135 902	60.4	172 143	76.5	190 263	84.6	244 624	108.7			P	5 484	743	6 946	941	1 040	9 871	1 338	92 801	41.2	117 549	52.2	129 922	57.7		167 043		74.2	2	11 554	1 566	14 635	1 983	2 192	20 798	2 818	214 344	95.3	271 503	120.7	300 082	133.4	385 820	171.5	P	8 858	1 200	11 220	1 520	1 680	15 945	2 161	166 535	74.0	210 945	93.8	233 149	103.6	299 764	133.2	2	7 591	1 029	9 615	1 303	1 440	13 663	1 851	143 557	63.8	181 839	80.8	200 980	89.3	258 403	114.8																																																												
3 1/2	9.50	N	14 146	1 917	17 918	2 428	2 684	25 463	3 450	194 264	86.3	246 068	109.4	271 970	120.9	349 676	155.4	P	11 094		1 503	14 052	1 904	2 104	19 968	2 706	152 979	68.0	193 774	86.1	214 171	95.2	275 363	122.4	2	9 612	1 302		12 176	1 650	1 823	17 302	2 344	132 793	59.0	168 204	74.8	185 910	82.6	239 027	106.2	N	18 551		2 514	23 498	3 184	3 519	33 392	4 525	271 569	120.7	343 988	152.9	380 197	169.0	488 825	217.3	P		14 361	1 946	18 191	2 465	2 724	25 850	3 503	212 150	94.3	268 723	119.4	297 010	132.0	381 870	169.7	2	12 365	1 675	15 663	2 122	2 346	22 258	3 016	183 398	81.5	232 304	103.2	256 757	114.1	330 116	146.7	N	21 086	2 857	26 708	3 619	4 000	37 954	5 143	322 775	143.5	408 848	181.7	451 885	200.8	580 995	258.2	P	16 146	2 188	20 452	2 771	3 063	29 063	3 938	250 620	111.4	317 452	141.1	350 868	155.9	451 115	200.5	2	13 828	1 874	17 515	2 373	2 623	24 890	3 373	215 967	96.0	273 558	121.6

(1) N: Based on the shear strength equal to 57.7% of minimum yield strength and nominal thickness.
P: Based on the shear strength equal to 57.7% of minimum yield strength and torsional data based on 20% of uniform wear on outside diameter and tensile data based on 20% uniform wear on outside diameter.

2: Based on the shear strength equal to 57.7% of minimum yield strength and torsional data based on 30% of uniform wear on outside diameter and tensile data based on 30% uniform wear on outside diameter

GEOMETRIC CHARACTERISTICS OF DRILL PIPES (New pipe bodies and tool joints) (continued)

Nominal diameter (in)	Nominal weight (lb/ft)	Wall thickness (mm)	ID		Cross-section (mm ²)	Polar moment of inertia (mm ⁴)	Polar modulus (mm ³)	Upset and grade		Type of tool joint	Tool joint OD (mm)	Tool joint ID (mm)	Approximate weight including tool joint	
			(in)	(mm)									(kg/m)	(lb/ft)
5 (127 mm)	25.60	12.70	4.000	101.60	4 560	15 078 604	237 458	IEU	X	NC50 (XH)	165.1	76.2	41.40	27.82
								IEU	X	NC50 (IF)	168.3	73.2	41.77	28.07
								IEU	X	5 1/2 FH	177.8	88.9	42.48	28.55
5 1/2 (139.70 mm)	21.90	9.17	4.778	121.36	3 760	16 096 385	230 442	IEU	E	FH	177.8	101.6	35.41	23.79
								IEU	X	FH	177.8	95.3	36.33	24.41
								IEU	G	FH	184.2	88.9	37.59	25.26
6 5/8 (168.28 mm)	27.70	9.19	5.901	149.90	4 593	29 159 551	346 560	IEU	S	FH	190.5	76.2	39.25	26.37
								IEU	E	FH	177.8	101.6	39.16	26.31
								IEU	X	FH	184.2	88.9	41.29	27.75
6 5/8 (168.28 mm)	25.20	8.38	5.965	151.52	4 210	26 981 773	320 677	IEU	S	FH	190.5	76.2	42.94	28.85
								IEU	E	FH	203.2	127.0	41.00	27.55
								IEU	X	FH	203.2	127.0	41.00	27.55
6 5/8 (168.28 mm)	27.70	9.19	5.901	149.90	4 593	29 159 551	346 560	IEU	G	FH	209.6	120.7	42.57	28.61
								IEU	S	FH	215.9	107.9	44.70	30.04
								IEU	E	FH	203.2	127.0	43.76	29.41
6 5/8 (168.28 mm)	27.70	9.19	5.901	149.90	4 593	29 159 551	346 560	IEU	X	FH	209.6	120.7	45.32	30.45
								IEU	G	FH	209.6	120.7	45.32	30.45
								IEU	S	FH	215.9	107.9	47.44	31.88

mm x 0.0394 = in mm² x 0.00155 = in² mm³ x 6.10 10⁻⁵ = in³ mm⁴ x 2.40 10⁻⁶ = in⁴

**NEW (N), PREMIUM CLASS (P) AND CLASS 2 (2) DRILL PIPE,
TORSIONAL AND TENSILE DATA
(API RP 7G, 15th edition, January 1, 1995)**

Size OD (in)	Nominal weight (lb/ft)	Class	Torsional yield strength ¹						Tensile yield strength									
			E		95		105		135		E		95		105		135	
			(ft.lb)	(daN.m)	(ft.lb)	(daN.m)	(ft.lb)	(daN.m)	(ft.lb)	(daN.m)	(lb)	(10 ³ daN)	(lb)	(10 ³ daN)	(lb)	(10 ³ daN)	(lb)	(10 ³ daN)
2 3/8	4.85	N	4 763	645	6 033	817	904	1 162	97 817	43.5	123 902	55.1	136 944	60.9	176 071	78.3		
		P	3 725	505	4 719	639	707	909	76 893	34.2	97 398	43.3	107 650	47.8	138 407	61.5		
		2	3 224	437	4 083	553	612	786	66 686	29.6	84 469	37.5	93 360	41.5	120 035	53.3		
	6.65	N	6 250	847	7 917	1 073	1 186	11 251	138 214	61.4	175 072	77.8	193 500	86.0	248 786	110.6		
		P	4 811	652	6 093	826	913	8 659	107 616	47.8	136 313	60.6	150 662	67.0	193 709	86.1		
		2	4 130	560	5 232	709	783	7 434	92 871	41.3	117 636	52.3	130 019	57.8	167 167	74.3		
2 7/8	6.85	N	8 083	1 095	10 238	1 387	1 533	14 549	135 902	60.4	172 143	76.5	190 263	84.6	244 624	108.7		
		P	6 332	858	8 020	1 087	1 201	11 397	106 946	47.5	135 465	60.2	149 725	66.5	192 503	85.6		
		2	5 484	743	6 946	941	1 040	9 871	92 801	41.2	117 549	52.2	129 922	57.7	167 043	74.2		
10.40		N	11 554	1 566	14 635	1 983	2 192	20 798	214 344	95.3	271 503	120.7	300 082	133.4	385 820	171.5		
		P	8 858	1 200	11 220	1 520	1 680	15 945	166 535	74.0	210 945	93.8	233 149	103.6	299 764	133.2		
		2	7 591	1 029	9 615	1 303	1 440	13 663	143 557	63.8	181 839	80.8	200 980	89.3	258 403	114.8		
3 1/2	9.50	N	14 146	1 917	17 918	2 428	2 684	25 463	194 264	86.3	246 068	109.4	271 970	120.9	349 676	155.4		
		P	11 094	1 503	14 052	1 904	2 104	19 968	152 979	68.0	193 774	86.1	214 171	95.2	275 363	122.4		
		2	9 612	1 302	12 176	1 650	1 823	17 302	132 793	59.0	168 204	74.8	185 910	82.6	239 027	106.2		
13.30		N	18 551	2 514	23 498	3 184	3 519	33 392	271 569	120.7	343 988	152.9	380 197	169.0	488 825	217.3		
		P	14 361	1 946	18 191	2 465	2 724	25 850	212 150	94.3	268 723	119.4	297 010	132.0	381 870	169.7		
		2	12 365	1 675	15 663	2 122	2 346	22 258	183 398	81.5	232 304	103.2	256 757	114.1	330 116	146.7		
15.50		N	21 086	2 857	26 708	3 619	4 000	37 954	322 775	143.5	408 848	181.7	451 885	200.8	580 995	258.2		
		P	16 146	2 188	20 452	2 771	3 063	29 063	250 620	111.4	317 452	141.1	350 868	155.9	451 115	200.5		
		2	13 828	1 874	17 515	2 373	2 623	24 890	215 967	96.0	273 558	121.6	302 354	134.4	388 741	172.8		

(1) N: Based on the shear strength equal to 57.7% of minimum yield strength and nominal thickness.

P: Based on the shear strength equal to 57.7% of minimum yield strength and torsional data based on 20% of uniform wear on outside diameter and torsional data based on 20% uniform wear on outside diameter.

2: Based on the shear strength equal to 57.7% of minimum yield strength and torsional data based on 30% of uniform wear on outside diameter and torsional data based on 30% uniform wear on outside diameter

**NEW (N), PREMIUM CLASS (P) AND CLASS 2 (2) DRILL PIPE,
TORSIONAL AND TENSILE DATA (continued)
(API RP 7G, 15th edition, January 1, 1995)**

Size OD	Nominal weight	Class	Torsional yield strength ¹						Tensile yield strength									
			E		95		105		135		E		95		105		135	
			(ft. lb)	(daN.m)	(ft. lb)	(daN.m)	(ft. lb)	(daN.m)	(ft. lb)	(daN.m)	(lb)	(10 ³ daN)	(lb)	(10 ³ daN)	(lb)	(10 ³ daN)	(lb)	(10 ³ daN)
4	11.85	N	19 474	2 639	24 668	3 343	27 264	3 694	4 750	230 755	102.6	292 290	129.9	323 057	143.6	415 360	184.6	
		P	15 310	2 075	19 392	2 628	21 433	2 904	3 734	182 016	80.9	230 554	102.5	254 823	113.3	327 630	145.6	
		2	13 281	1 800	16 823	2 280	18 594	2 520	3 239	158 132	70.3	200 301	89.0	221 385	98.4	284 638	126.5	
		N	23 288	3 156	29 498	3 997	32 603	4 418	5 680	285 359	126.8	361 454	160.6	399 502	177.6	513 646	228.3	
		P	18 196	2 466	23 048	3 123	25 474	3 452	4 438	224 182	99.6	283 963	126.2	313 854	139.5	403 527	179.3	
		2	15 738	2 133	19 935	2 701	22 034	2 986	3 839	194 363	86.4	246 193	109.4	272 108	120.9	349 852	155.5	
4 1/2	13.75	N	25 810	3 497	32 692	4 430	36 134	4 896	6 295	324 118	144.1	410 550	182.5	453 765	201.7	583 413	259.3	
		P	20 067	2 719	25 418	3 444	28 094	3 807	4 894	253 851	112.8	321 544	142.9	355 391	158.0	456 931	203.1	
		2	17 315	2 346	21 932	2 972	24 241	3 285	4 223	219 738	97.7	278 335	123.7	307 633	136.7	395 528	175.8	
		N	30 807	4 174	39 022	5 288	43 130	5 844	7 514	330 558	146.9	418 707	186.1	462 781	205.7	595 004	264.4	
		P	24 139	3 271	30 576	4 143	33 795	4 579	5 888	260 165	115.6	329 542	146.5	364 231	161.9	468 297	208.1	
		2	20 908	2 833	26 483	3 588	29 271	3 966	5 099	225 771	100.3	285 977	127.1	316 080	140.5	406 388	180.6	
16.60	20.00	N	36 901	5 000	46 741	6 333	51 661	7 000	9 000	412 358	183.3	522 320	232.1	577 301	256.6	742 244	329.9	
		P	28 683	3 887	36 332	4 923	40 157	5 441	6 996	322 916	143.5	409 026	181.8	452 082	200.9	581 248	258.3	
		2	24 747	3 353	31 346	4 247	34 645	4 694	6 036	279 502	124.2	354 035	157.3	391 302	173.9	503 103	223.6	
		N	40 912	5 544	51 821	7 022	57 276	7 761	9 978	471 239	209.4	596 903	265.3	659 734	293.2	848 230	377.0	
		P	31 587	4 280	40 010	5 421	44 222	5 992	7 704	367 566	163.4	465 584	206.9	514 593	228.7	661 620	294.1	
		2	27 161	3 680	34 404	4 662	38 026	5 153	6 625	317 497	141.1	402 163	178.7	444 496	197.6	571 495	254.0	

(1) See note B 13.

**NEW (N), PREMIUM CLASS (P) AND CLASS 2 (2) DRILL PIPE,
TORSIONAL AND TENSILE DATA (continued)
(API RP 7G, 15th edition, January 1, 1995)**

Size OD (in)	Nominal weight (lb/ft)	Class	Torsional yield strength ¹						Tensile yield strength									
			E		95		105		135		E		95		105		135	
			(ft.lb)	(daN.m)	(ft.lb)	(daN.m)	(ft.lb)	(daN.m)	(ft.lb)	(daN.m)	(lb)	(10 ³ daN)	(lb)	(10 ³ daN)	(lb)	(10 ³ daN)	(lb)	(10 ³ daN)
5	16.25	N	35 044	4 749	44 389	6 015	49 062	6 648	8 547	328 073	145.8	415 559	184.7	459 302	204.1	590 531	262.5	
		P	27 607	3 741	34 969	4 738	38 650	5 237	6 733	259 155	115.2	328 263	145.9	362 817	161.3	466 479	207.3	
		2	23 974	3 249	30 368	4 115	33 564	4 548	5 847	225 316	100.1	285 400	126.8	315 442	140.2	405 568	180.3	
		N	41 167	5 578	52 144	7 066	57 633	7 809	10 041	395 595	175.8	501 087	222.7	553 833	246.1	712 070	316.5	
		P	32 285	4 375	40 895	5 541	45 199	6 125	7 874	311 535	138.5	394 612	175.4	436 150	193.8	560 764	249.2	
		2	27 976	3 791	35 436	4 802	39 166	5 307	6 823	270 432	120.2	342 548	152.2	378 605	168.3	486 778	216.3	
5.60	25.60	N	52 257	7 081	66 192	8 969	73 159	9 913	12 746	530 144	235.6	671 515	298.5	742 201	329.9	954 259	424.1	
		P	40 544	5 494	51 356	6 959	56 762	7 691	9 889	414 690	184.3	525 274	233.5	580 566	258.0	746 443	331.8	
		2	34 947	4 735	44 267	5 998	48 926	6 630	8 524	368 731	159.4	454 392	202.0	502 223	223.2	645 715	287.0	
		N	44 074	5 972	55 826	7 564	61 703	8 361	10 750	372 181	165.4	471 429	209.5	521 053	231.6	669 925	297.7	
		P	34 764	4 711	44 035	5 967	48 670	6 595	8 479	294 260	130.8	372 730	165.7	411 965	183.1	529 669	235.4	
		2	30 208	4 093	38 263	5 185	42 291	5 730	7 368	255 954	113.8	324 208	144.1	358 335	159.3	460 717	204.8	
5.90	21.90	N	50 710	6 871	64 233	8 704	70 994	9 620	12 368	437 116	194.3	553 681	246.1	611 963	272.0	786 809	349.7	
		P	39 863	5 401	50 494	6 842	55 809	7 562	9 723	344 780	153.2	436 721	194.1	482 692	214.5	620 604	275.8	
		2	34 582	4 686	43 804	5 936	48 414	6 560	8 435	299 533	133.1	379 409	168.6	419 346	186.4	539 160	239.6	
		N	56 574	7 666	71 660	9 710	79 204	10 732	13 799	497 222	221.0	629 814	279.9	696 111	309.4	894 999	397.8	
		P	44 320	6 005	56 139	7 607	62 048	8 408	10 810	391 285	173.9	495 627	220.3	547 799	243.5	704 313	313.0	
		2	38 383	5 201	48 619	6 588	53 737	7 281	9 362	339 533	150.9	430 076	191.1	475 347	211.3	611 160	271.6	
6.5/8	25.20	N	70 580	9 564	89 402	12 114	98 812	13 389	17 215	489 464	217.5	619 988	275.6	685 250	304.6	881 035	391.6	
		P	55 766	7 556	71 522	9 691	79 050	10 711	14 872	387 466	172.2	490 790	218.1	542 452	241.1	697 438	310.0	
		2	48 497	6 571	61 430	8 324	67 896	9 200	11 829	337 236	149.9	427 166	189.9	472 131	209.8	607 026	269.8	
		N	76 295	10 338	96 640	13 095	106 813	14 473	18 608	534 199	237.4	676 651	300.7	747 877	332.4	961 556	427.4	
		P	60 192	8 156	77 312	10 476	85 450	11 579	14 887	422 419	187.7	535 064	237.8	591 387	262.8	760 354	337.9	
		2	52 308	7 088	66 257	8 978	73 231	9 923	12 758	367 455	163.3	465 443	206.9	514 437	228.6	661 419	294.0	

(1) See note B 13.

**NEW (N), PREMIUM CLASS (P) AND CLASS 2 (2) DRILL PIPE,
COLLAPSE AND BURST PRESSURE DATA
(API RP 7G, 15th edition, January 1, 1995)**

Size OD (in)	Nominal weight (lb/ft)	Class	Collapse pressure						Burst pressure									
			E		95		105		135		E		95		105		135	
			(psi)	(MPa)	(psi)	(MPa)	(psi)	(MPa)	(psi)	(MPa)	(psi)	(MPa)	(psi)	(MPa)	(psi)	(MPa)	(psi)	(MPa)
2 3/8	4.85	N	11 040	76.1	13 984	96.4	15 456	106.6	19 035	131.2	10 500	72.4	13 300	91.7	14 700	101.4	18 900	130.3
		P	8 522	58.8	10 161	70.1	10 912	75.2	12 891	88.9	9 600	66.2	12 160	83.8	13 440	92.7	17 280	119.1
		2	6 852	47.2	7 996	55.1	8 491	58.5	9 664	66.6	8 400	57.9	10 640	73.4	11 760	81.1	15 120	104.2
	6.65	N	15 599	107.6	19 759	136.2	21 839	150.6	28 079	193.6	15 474	106.7	19 600	135.1	21 663	149.4	27 853	192.0
		P	13 378	92.2	16 945	116.8	18 729	129.1	24 080	166.0	14 147	97.5	17 920	123.6	19 806	136.6	25 465	175.6
		2	12 138	83.7	15 375	106.0	16 993	117.2	21 849	150.6	12 379	85.4	15 680	108.1	17 331	119.5	22 282	153.6
2 7/8	6.85	N	10 467	72.2	12 940	89.2	14 020	96.7	17 034	117.4	9 907	68.3	12 548	86.5	13 869	95.6	17 832	122.9
		P	7 640	52.7	9 017	62.2	9 633	66.4	11 186	77.1	9 057	62.4	11 473	79.1	12 680	87.4	16 303	112.4
		2	6 055	41.7	6 963	48.0	7 335	50.6	8 123	56.0	7 925	54.6	10 039	69.2	11 095	76.5	14 265	98.4
	10.40	N	16 509	113.8	20 911	144.2	23 112	159.4	29 716	204.9	16 526	113.9	20 933	144.3	23 137	159.5	29 747	205.1
		P	14 223	98.1	18 016	124.2	19 912	137.3	25 602	176.5	15 110	104.2	19 139	132.0	21 153	145.8	27 197	187.5
		2	12 938	89.2	16 388	113.0	18 113	124.9	23 288	160.6	13 221	91.2	16 746	115.5	18 509	127.6	23 798	164.1
3 1/2	9.50	N	10 001	69.0	12 077	83.3	13 055	90.0	15 748	108.6	9 525	65.7	12 065	83.2	13 335	91.9	17 145	118.2
		P	7 074	48.8	8 284	57.1	8 813	60.8	10 093	69.6	8 709	60.0	11 031	76.1	12 192	84.1	15 675	108.1
		2	5 544	38.2	6 301	43.4	6 596	45.5	7 137	49.2	7 620	52.5	9 652	66.5	10 668	73.6	13 716	94.6
	13.30	N	14 113	97.3	17 877	123.3	19 758	136.2	25 404	175.2	13 800	95.1	17 480	120.5	19 320	133.2	24 840	171.3
		P	12 015	82.8	15 218	104.9	16 820	116.0	21 626	149.1	12 617	87.0	15 982	110.2	17 664	121.8	22 711	156.6
		2	10 858	74.9	13 753	94.8	15 042	103.7	18 396	126.8	11 040	76.1	13 984	96.4	15 456	106.6	19 872	137.0
15.50	N	16 774	115.7	21 247	146.5	23 484	161.9	30 194	208.2	16 838	116.1	21 328	147.1	23 573	162.5	30 308	209.0	
	P	14 472	99.8	18 331	126.4	20 260	139.7	26 049	179.6	15 394	106.1	19 499	134.4	21 552	148.6	27 710	191.1	
	2	13 174	90.8	16 686	115.0	18 443	127.2	23 712	163.5	13 470	92.9	17 062	117.6	18 858	130.0	24 246	167.2	

Calculations are based on formulas in API 5 C3

N: Nominal ID and OD.

P: Minimum wall of 80% nominal wall. Collapse pressures are based on uniform OD wear. Burst pressures are based on uniform wear and nominal OD.

2: Minimum wall of 70% nominal wall. Collapse pressures are based on uniform OD wear. Burst pressures are based on uniform wear and nominal OD.

**NEW (N), PREMIUM CLASS (P) AND CLASS 2 (2) DRILL PIPE,
COLLAPSE AND BURST PRESSURE DATA (continued)
(API RP 7G, 15th edition, January 1, 1995)**

Size OD (in)	Nominal weight (lb/ft)	Class	Collapse pressure						Burst pressure									
			E		95		105		135		E		95		105		135	
			(psi)	(MPa)	(psi)	(MPa)	(psi)	(MPa)	(psi)	(MPa)	(psi)	(MPa)	(psi)	(MPa)	(psi)	(MPa)	(psi)	(MPa)
4	11.85	N	8 381	57.8	9 978	68.8	10 708	73.8	12 618	87.0	8 597	59.3	10 889	75.1	12 036	83.0	15 474	106.7
		P	5 704	39.3	6 508	44.9	6 827	47.1	7 445	51.3	7 860	54.2	9 956	68.6	11 004	75.9	14 148	97.5
		2	4 311	29.7	4 702	32.4	4 876	33.6	5 436	37.5	6 878	47.4	8 712	60.1	9 629	66.4	12 380	85.4
		N	11 354	78.3	14 382	99.2	15 896	109.6	20 141	138.9	10 828	74.7	13 716	94.6	15 159	104.5	19 491	134.4
		P	9 012	62.1	10 795	74.4	11 622	80.1	13 836	95.4	9 900	68.3	12 540	86.5	13 860	95.6	17 820	122.9
		2	7 295	50.3	8 570	59.1	9 134	63.0	10 520	72.5	8 663	59.7	10 973	75.7	12 128	83.6	15 593	107.5
4 1/2	13.75	N	12 896	88.9	16 335	112.6	18 055	124.5	23 213	160.0	12 469	86.0	15 794	108.9	17 456	120.4	22 444	154.7
		P	10 914	75.2	13 825	95.3	15 190	104.7	18 593	128.2	11 400	78.6	14 440	99.6	15 960	110.0	20 520	141.5
		2	9 531	65.7	11 468	79.1	12 374	85.3	14 840	102.3	9 975	68.8	12 635	87.1	13 965	96.3	17 955	123.8
		N	7 173	49.5	8 412	58.0	8 956	61.7	10 283	70.9	7 904	54.5	10 012	69.0	11 066	76.3	14 228	98.1
		P	4 686	32.3	5 190	35.8	5 352	36.9	5 908	40.7	7 227	49.8	9 154	63.1	10 117	69.8	13 008	89.7
		2	3 397	23.4	3 845	26.5	4 016	27.7	4 287	29.6	6 323	43.6	8 010	55.2	8 853	61.0	11 382	78.5
16.60	16.60	N	10 392	71.7	12 765	88.0	13 825	95.3	16 773	115.6	9 829	67.8	12 450	85.8	13 761	94.9	17 693	122.0
		P	7 525	51.9	8 868	61.1	9 467	65.3	10 964	75.6	8 987	62.0	11 383	78.5	12 581	86.7	16 176	111.5
		2	5 951	41.0	6 828	47.1	7 185	49.5	7 923	54.6	7 863	54.2	9 960	68.7	11 009	75.9	14 154	97.6
		N	12 964	89.4	16 421	113.2	18 149	125.1	23 335	160.9	12 542	86.5	15 886	109.5	17 558	121.1	22 575	155.6
		P	10 975	75.7	13 901	95.8	15 350	105.8	18 806	129.7	11 467	79.1	14 524	100.1	16 053	110.7	20 640	142.3
		2	9 631	66.4	11 598	80.0	12 520	86.3	15 033	103.6	10 033	69.2	12 709	87.6	14 047	96.9	18 060	124.5
22.82	22.82	N	14 815	102.1	18 765	129.4	20 741	143.0	26 667	183.9	14 583	100.5	18 472	127.4	20 417	140.8	26 250	181.0
		P	12 655	87.3	16 030	110.5	17 718	122.2	22 780	157.1	13 333	91.9	16 889	116.4	18 667	128.7	24 000	165.5
		2	11 458	79.0	14 514	100.1	16 042	110.6	20 510	141.4	11 667	80.4	14 779	101.9	16 333	112.6	21 000	144.8

See note B 16.

**NEW (N), PREMIUM CLASS (P) AND CLASS 2 (2) DRILL PIPE,
COLLAPSE AND BURST PRESSURE DATA (continued)
(API RP 7G, 15th edition, January 1, 1995)**

Size OD	Nominal weight (lb/ft)	Class	Collapse pressure						Burst pressure									
			E		95		105		135		E		95		105		135	
			(psi)	(MPa)	(psi)	(MPa)	(psi)	(MPa)	(psi)	(MPa)	(psi)	(MPa)	(psi)	(MPa)	(psi)	(MPa)	(psi)	(MPa)
5	16.25	N	6 938	47.8	8 108	55.9	8 616	59.4	9 831	67.8	7 770	53.6	9 842	67.9	10 878	75.0	13 986	96.4
		P	4 490	31.0	4 935	34.0	5 067	34.9	5 661	39.0	7 104	49.0	8 998	62.0	9 946	68.6	12 787	88.2
		2	3 275	22.6	3 696	25.5	3 850	26.5	4 065	28.0	6 216	42.9	7 874	54.3	8 702	60.0	11 189	77.1
	19.50	N	9 962	68.7	12 026	82.9	12 999	89.6	15 672	108.1	9 503	65.5	12 037	83.0	13 304	91.7	17 105	117.9
		P	7 041	48.5	8 241	56.8	8 765	60.4	10 029	69.1	8 688	59.9	11 005	75.9	12 163	83.9	15 638	107.8
		2	5 514	38.0	6 262	43.2	6 552	45.2	7 079	48.8	7 602	52.4	9 629	66.4	10 643	73.4	13 684	94.3
25.60	N	13 500	93.1	17 100	117.9	18 900	130.3	24 300	167.5	13 125	90.5	16 625	114.6	18 375	126.7	23 625	162.9	
	P	11 458	79.0	14 514	100.1	16 042	110.6	20 510	141.4	12 000	82.7	15 200	104.8	16 800	115.8	21 600	148.9	
	2	10 338	71.3	12 640	87.1	13 685	94.4	16 587	114.4	10 500	72.4	13 300	91.7	14 700	101.4	18 900	130.3	
5 1/2	19.20	N	6 039	41.6	6 942	47.9	7 313	50.4	8 093	55.8	7 255	50.0	9 189	63.4	10 156	70.0	13 058	90.0
		P	3 736	25.8	4 130	28.5	4 336	29.9	4 714	32.5	6 633	45.7	8 401	57.9	9 286	64.0	11 939	82.3
		2	2 835	19.5	3 128	21.6	3 215	22.2	3 265	22.5	5 804	40.0	7 351	50.7	8 125	56.0	10 447	72.0
	21.90	N	8 413	58.0	10 019	69.1	10 753	74.1	12 679	87.4	8 615	59.4	10 912	75.2	12 061	83.2	15 507	106.9
		P	5 730	39.5	6 542	45.1	6 865	47.3	7 496	51.7	7 876	54.3	9 977	68.8	11 027	76.0	14 177	97.7
		2	4 334	29.9	4 733	32.6	4 899	33.8	5 464	37.7	6 892	47.5	8 730	60.2	9 649	66.5	12 405	85.5
24.70	N	10 464	72.1	12 933	89.2	14 013	96.6	17 023	117.4	9 903	68.3	12 544	86.5	13 865	95.6	17 826	122.9	
	P	7 635	52.6	9 011	62.1	9 626	66.4	11 177	77.1	9 055	62.4	11 469	79.1	12 676	87.4	16 298	112.4	
	2	6 050	41.7	6 957	48.0	7 329	50.5	8 115	56.0	7 923	54.6	10 035	69.2	11 092	76.5	14 261	98.3	
6 5/8	25.20	N	4 788	33.0	5 321	36.7	5 500	37.9	6 036	41.6	6 538	45.1	8 281	57.1	9 153	63.1	11 768	81.1
		P	2 931	20.2	3 252	22.4	3 353	23.1	3 429	23.6	5 977	41.2	7 571	52.2	8 368	57.7	10 759	74.2
		2	2 227	15.4	2 343	16.2	2 346	16.2	2 346	16.2	5 230	36.1	6 625	45.7	7 322	50.5	9 414	64.9
	27.70	N	5 894	40.6	6 755	46.6	7 103	49.0	7 813	53.9	7 172	49.4	9 084	62.6	10 040	69.2	12 909	89.0
		P	3 615	24.9	4 029	27.8	4 222	29.1	4 562	31.5	6 557	45.2	8 306	57.3	9 180	63.3	11 803	81.4
		2	2 765	19.1	3 037	20.9	3 113	21.5	3 148	21.7	5 737	39.6	7 267	50.1	8 032	55.4	10 327	71.2

See note B 16.

RECOMMENDED MINIMUM OD* AND MAKE-UP TORQUE OF WELD-ON TYPE TOOL JOINTS BASED ON TORSIONAL STRENGTH OF BOX AND DRILL PIPE (API RP 7G, 15th edition, January 1, 1995)

Drill pipe			New tool joint data						Premium class						Class 2					
Nominal size (in)	Nominal weight (lb/ft)	Type upset and grade	Connection	New OD		New ID		Make-up torque ⁶ (ft.lb)	Make-up torque ⁶ (daN.m)	Minimum OD tool joint		Minimum box shoulder with eccentric wear		Minimum OD tool joint		Minimum box shoulder with eccentric wear		Make-up torque for minimum OD tool joint		
				(in)	(mm)	(in)	(mm)			(in)	(mm)	(in)	(mm)	(in)	(mm)	(in)	(mm)	(ft.lb)	(daN.m)	
2 3/8	4.85	EU 75	NC26 WO 2 3/8 OHLW 2 3/8 SL-H90	3 3/8	85.7	1 3/4	44.5	4 125 B	559	79.4	3 1/8	77.8	3/64	1.2	3 3/32	78.6	1/32	0.8	1 689	229
	4.85	EU 75		3 3/8	85.7	2	50.8	2 586 P	350	77.8	3 1/16	77.8	1/16	1.6	3 1/32	77.0	3/64	1.2	1 746	237
	4.85	EU 75		3 1/8	79.4	2	50.8	2 713 P	368	76.2	3	76.2	1/16	1.6	2 31/32	75.4	3/64	1.2	1 589	215
	4.85	EU 75		3 1/4	82.6	2	50.8	3 074 P	417	75.4	2 31/32	75.4	1/16	1.6	2 15/16	74.6	3/64	1.2	1 726	234
2 3/8	6.65	IU 75	2 3/8 PAC ² NC26 2 3/8 SL-H90 2 3/8 OHSW	2 7/8	73.0	1 3/8	34.9	2 813 P	381	70.6	2 25/32	70.6	9/64	3.6	2 23/32	69.1	7/64	2.8	2 055	278
	6.65	EU 75		3 3/8	85.7	1 3/4	44.5	4 125 B	559	81.0	3 3/16	81.0	5/64	2.0	3 5/32	80.2	1/16	1.6	2 204	299
	6.65	EU 75		3 1/4	82.6	2	50.8	3 074 P	417	77.0	1 3/2	77.0	3/32	2.4	2 31/32	75.4	1/16	1.6	1 996	270
	6.65	EU 75		3 1/4	82.6	1 3/4	44.5	3 891 B	527	77.8	3 1/16	77.8	3/32	2.4	3 1/32	77.0	5/64	2.0	2 075	281
2 3/8	6.65	EU 95	NC26	3 3/8	85.7	1 3/4	44.5	4 125 B	559	82.6	3 1/4	82.6	7/64	2.8	3 7/32	81.8	3/32	2.4	2 734	370
2 3/8	6.65	EU 105	NC26 ²	3 3/8	85.7	1 3/4	44.5	4 125 B	559	83.3	3 9/32	83.3	1/8	3.2	3 1/4	82.6	7/64	2.8	3 005	407
2 7/8	6.85	EU 75	NC31 2 7/8 WO 2 7/8 OHLW ² 2 7/8 SL-H90	4 1/8	104.8	2 1/8	54.0	7 122 P	965	93.7	3 11/16	93.7	5/64	2.0	3 21/32	92.9	1/16	1.6	2 804	380
	6.85	EU 75		4 1/8	104.8	2 7/16	61.9	4 318 P	585	92.1	3 5/8	92.1	5/64	2.0	3 19/32	91.3	1/16	1.6	2 876	390
	6.85	EU 75		3 3/4	95.3	2 7/16	61.9	3 351 P	654	88.9	3 1/2	88.9	7/64	2.8	3 7/16	87.3	5/64	2.0	2 666	361
	6.85	EU 75		3 7/8	98.4	2 7/16	61.9	4 575 P	620	88.9	3 1/2	88.9	3/32	2.4	3 7/16	87.3	1/16	1.6	2 666	361
2 7/8	10.40	EU 75	NC31 2 7/8 XH NC26 ² 2 7/8 OHSW ² 2 7/8 SL-H90 2 7/8 PAC ²	4 1/8	104.8	2 1/8	54.0	7 122 P	965	96.8	3 13/16	96.8	9/64	3.6	3 3/4	95.3	7/64	2.8	3 867	524
	10.40	IU 75		4 1/4	108.0	1 7/8	47.6	7 969 P	1 080	94.5	3 23/32	94.5	9/64	3.6	3 21/32	92.9	7/64	2.8	3 664	496
	10.40	IU 75		3 3/8	85.7	1 3/4	44.5	4 125 B	559	85.7	3 3/8	85.7	11/64	4.4	3 11/32	84.9	5/32	4.0	3 839	520
	10.40	EU 75		3 7/8	98.4	2 5/32	54.8	5 270 P	714	91.3	3 19/32	91.3	5/32	4.0	3 9/16	90.5	7/64	2.8	3 941	534
2 7/8	10.40	EU 75	2 7/8 SL-H90	3 1/8	79.4	1 1/2	38.1	3 439 P	466	79.4	3 1/8	79.4	15/64	6.0	3 1/8	79.4	15/64	6.0	3 770	511
	10.40	EU 95		4 1/8	104.8	2	50.8	7 918 P	1 073	99.2	3 29/32	99.2	3/16	4.8	3 27/32	97.6	5/32	4.0	4 969	673
2 7/8	10.40	EU 95	2 7/8 SL-H90 ²	3 7/8	98.4	2 5/32	54.8	6 773 P	918	93.7	3 11/16	93.7	3/16	4.8	3 5/8	92.1	5/32	4.0	4 915	666
	10.40	EU 105		4 1/8	104.8	2	50.8	7 918 P	1 073	100.0	3 15/16	100.0	13/64	5.2	3 7/8	98.4	11/64	4.4	5 345	724
2 7/8	10.40	EU 135	NC31	4 3/8	111.1	1 5/8	41.3	10 167 P	1 378	103.2	4 1/16	103.2	17/64	6.7	4	101.6	15/64	6.0	6 893	934
3 1/2	9.50	EU 75	NC38 NC38 3 1/2 OHLW 3 1/2 SL-H90	4 3/4	120.7	3	76.2	7 688 P	1 042	111.9	4 13/32	111.9	1/8	3.2	4 11/32	110.3	3/32	2.4	4 797	650
	9.50	EU 75		4 3/4	120.7	2 11/16	68.3	10 864 P	1 472	111.9	4 13/32	111.9	1/8	3.2	4 11/32	110.3	3/32	2.4	4 797	650
	9.50	EU 75		4 3/4	120.7	3	76.2	7 218 P	978	108.7	4 9/32	108.7	1/8	3.2	4 1/4	108.0	7/64	2.8	4 868	660
	9.50	EU 75		4 5/8	117.5	3	76.2	7 584 P	1 028	106.4	4 3/16	106.4	7/64	2.8	4 5/32	105.6	3/32	2.4	5 003	678

See notes at the end of B 23.

RECOMMENDED MINIMUM OD* AND MAKE-UP TORQUE OF WELD-ON TYPE TOOL JOINTS BASED ON TORSIONAL STRENGTH OF BOX AND DRILL PIPE (continued)

(API RP 7G, 15th edition, January 1, 1995)

Drill pipe			New tool joint data						Premium class						Class 2					
Nominal size	Nominal weight (lb/ft)	Type upset and grade	Connection	New OD		New ID		Make-up torque ^g	Minimum OD tool joint		Minimum shoulder with eccentric wear		Make-up torque for minimum OD tool joint	Minimum OD tool joint		Minimum shoulder with eccentric wear		Make-up torque for minimum OD tool joint		
				(in)	(mm)	(in)	(mm)		(ft.lb)	(daN.m)	(in)	(mm)		(in)	(mm)	(in)	(mm)		(in)	(mm)
3 1/2	13.30	EU 75	NC38	4 3/4	120.7	2 11/16	68.3	10 864 P	1 472	114.3	11/64	4.4	7 274	986	4 7/16	112.7	9/64	3.6	6 288	849
	13.30	IU 75		4 1/8	104.8	2 1/8	54.0	7 122 P	965	101.6	15/64	6.0	6 893	934	3 15/16	100.0	13/64	5.2	6 110	828
	13.30	EU 75		4 3/4	120.7	2 11/16	68.3	10 387 P	1 407	111.9	3/16	4.8	7 278	986	4 11/32	110.3	5/32	4.0	6 229	844
	13.30	EU 75		5 1/4	133.4	2 3/4	69.9	14 300 P	1 938	115.1	1/8	3.2	7 064	957	4 1/2	114.3	7/64	2.8	6 487	879
	13.30	EU 95		5	127.0	2 9/16	65.1	12 196 P	1 653	116.7	7/32	5.6	8 822	1 195	4 17/32	115.1	3/16	4.8	7 785	1 055
	13.30	EU 95		4 5/8	117.5	2 11/16	68.3	11 137 P	1 509	111.1	13/64	5.2	8 742	1 185	4 5/16	109.5	11/64	4.4	7 647	1 036
13.30	EU 95	5 1/4	133.4	2 3/4	69.9	14 300 P	1 938	117.5	4 5/8	4.4	8 826	1 196	4 9/16	115.9	9/64	3.6	7 646	1 036		
3 1/2	13.30	EU 105	NC38	5	127.0	2 7/16	61.9	13 328 P	1 806	118.3	1/4	6.4	9 879	1 339	4 19/32	116.7	7/32	5.6	8 822	1 195
3 1/2	13.30	EU 135	NC40	5 3/8	136.5	2 7/16	61.9	17 958 P	2 433	127.0	9/32	7.1	12 569	1 703	4 29/32	124.6	15/64	6.0	10 768	1 459
	13.30	EU 135		5	127.0	2 1/8	54.0	15 909 P	2 156	122.2	21/64	8.3	12 614	1 709	4 23/32	119.9	9/32	7.1	10 957	1 485
3 1/2	15.50	EU 75	NC38	5	127.0	2 9/16	65.1	12 196 P	1 653	115.1	3/16	4.8	7 785	1 055	4 15/32	113.5	5/32	4.0	6 789	917
	15.50	EU 95		5	127.0	2 7/16	61.9	13 328 P	1 806	118.3	1/4	6.4	9 879	1 339	4 19/32	116.7	7/32	5.6	8 822	1 195
3 1/2	15.50	EU 105	NC38	5	127.0	2 1/8	54.0	15 909 P	2 156	119.9	9/32	7.1	10 957	1 485	4 5/8	117.5	15/64	6.0	9 348	1 267
	15.50	EU 105		5 1/4	133.4	2 9/16	65.1	16 656 P	2 257	125.4	1/4	6.4	11 363	1 540	4 27/32	123.0	13/64	5.2	9 595	1 300
3 1/2	15.50	EU 135	NC40	5 1/2	139.7	2 1/4	57.2	19 766 P	2 678	129.4	21/64	8.3	14 419	1 954	4 31/32	126.2	17/64	6.7	11 993	1 621
	11.85	EU 75		6	152.4	3 1/4	82.6	20 175 P	2 734	132.6	7/64	2.8	7 843	1 063	5 5/32	131.0	5/64	2.0	6 476	878
4	11.85	EU 75	NC46	5 3/4	146.1	3 7/16	87.3	17 285 P	2 342	132.6	7/64	2.8	7 843	1 063	5 5/32	131.0	5/64	2.0	6 476	878
	11.85	EU 75		5 1/4	133.4	3 15/32	88.1	13 186 P	1 787	127.0	9/64	3.6	7 866	1 066	4 15/16	125.4	7/64	2.8	6 593	893
	11.85	IU 75		5 1/2	139.7	2 13/16	71.4	21 224 P	2 876	123.8	7/64	2.8	7 630	1 034	4 27/32	123.0	3/32	2.4	6 962	943
	14.00	IU 75		5 1/4	133.4	2 13/16	71.4	14 024 P	1 909	122.2	4 13/16	4.8	9 017	1 222	4 3/4	120.7	5/32	4.0	7 877	1 067
	14.00	EU 75		6	152.4	3 1/4	82.6	20 175 P	2 734	134.1	5 9/32	3.6	9 233	1 251	5 7/32	132.6	7/64	2.8	7 843	1 063
	14.00	IU 75		4 5/8	117.5	2 9/16	65.1	9 102 P	1 233	112.7	4 7/16	6.0	8 782	1 190	4 3/8	111.1	13/64	5.2	7 817	1 059
14.00	EU 75	5 1/2	139.7	3 1/4	82.6	16 320 P	2 211	128.6	5 1/16	4.4	9 131	1 237	5	127.0	9/64	3.6	7 839	1 062		
	14.00	IU 75	5 1/2	139.7	2 13/16	71.4	21 224 P	2 876	125.4	4 15/16	3.6	8 986	1 218	4 7/8	123.8	7/64	2.8	7 630	1 034	
4	14.00	IU 95	NC40	5 1/4	133.4	2 11/16	68.3	15 404 P	2 087	125.4	1/4	6.4	11 363	1 540	4 27/32	123.0	13/64	5.2	9 595	1 300
	14.00	EU 95		6	152.4	3 1/4	82.6	20 175 P	2 734	136.5	3/16	4.8	11 363	1 540	5 5/16	134.9	5/32	4.0	9 937	1 346
	14.00	IU 95		5 1/2	139.7	2 13/16	71.4	21 224 P	2 876	127.8	3/16	4.8	11 065	1 499	4 31/32	126.2	5/32	4.0	9 673	1 311

See notes at the end of B 23.

**RECOMMENDED MINIMUM OD* AND MAKE-UP TORQUE OF WELD-ON TYPE TOOL JOINTS
BASED ON TORSIONAL STRENGTH OF BOX AND DRILL PIPE (continued)**
(API RP 7G, 15th edition, January 1, 1995)

Drill pipe			New tool joint data						Premium class						Class 2					
Nominal size (in)	Nominal weight (lb/ft)	Type upset and grade	Connection	New OD		New ID	Make-up torque ⁶		Minimum OD tool joint		Minimum box shoulder with eccentric wear		Make-up torque for minimum OD tool joint		Minimum OD tool joint		Minimum box shoulder with eccentric wear		Make-up torque for minimum OD tool joint	
				(in)	(mm)		(ft.lb)	(daN.m)	(in)	(mm)	(in)	(mm)	(ft.lb)	(daN.m)	(in)	(mm)	(ft.lb)	(daN.m)		
4	14.00	IU 105	NC40 NC46 4 H90	5 1/2	139.7	2 7/16	61.9	18 068 P	2 448	127.0	9/32	7.1	12 569	1 703	4 29/32	124.6	15/64	6.0	10 768	1 459
	14.00	IU 105		6	152.4	3 1/4	82.6	20 175 P	2 734	138.1	7/32	5.6	12 813	1 736	5 11/32	135.7	11/64	4.4	10 647	1 443
	14.00	IU 105		5 1/2	139.7	2 13/16	71.4	21 224 P	2 876	129.4	7/32	5.6	12 481	1 691	5 1/32	127.8	3/16	4.8	11 065	1 499
4	14.00	EU 135	NC46	6	152.4	3	76.2	23 538 P	3 189	141.3	9/32	7.1	15 787	2 139	5 1/2	139.7	1/4	6.4	14 288	1 936
	15.70	IU 75		5 1/4	133.4	2 11/16	68.3	15 404 P	2 087	123.8	7/32	5.6	10 179	1 379	4 25/32	121.4	11/64	4.4	8 444	1 144
	15.70	EU 75		6	152.4	3 1/4	82.6	20 175 P	2 734	134.9	5/32	4.0	9 937	1 346	5 1/4	133.4	1/8	3.2	8 535	1 157
4	15.70	IU 75	4 H90	5 1/2	139.7	2 13/16	71.4	21 224 P	2 876	126.2	5/32	4.0	9 673	1 311	4 29/32	124.6	1/8	3.2	8 305	1 125
	15.70	IU 95		5 1/2	139.7	2 7/16	61.9	18 068 P	2 448	127.0	9/32	7.1	12 569	1 703	4 29/32	124.6	15/64	6.0	10 768	1 459
	15.70	EU 95		6	152.4	3	76.2	23 538 P	3 189	138.1	7/32	5.6	12 813	1 736	5 11/32	135.7	11/64	4.4	10 647	1 443
4	15.70	IU 95	4 H90	5 1/2	139.7	2 13/16	71.4	21 224 P	2 876	129.4	7/32	5.6	12 481	1 691	5 1/32	127.8	3/16	4.8	11 065	1 499
	15.70	EU 105		6	152.4	3	76.2	23 538 P	3 189	138.9	15/64	6.0	13 547	1 836	5 13/32	137.3	13/64	5.2	12 085	1 638
	15.70	IU 105		5 1/2	139.7	2 13/16	71.4	21 224 P	2 876	131.0	1/4	6.4	13 922	1 886	5 1/16	128.6	13/64	5.2	11 770	1 595
4	15.70	IU 135	NC46	6	152.4	2 5/8	66.7	26 982 B	3 656	143.7	21/64	8.3	18 083	2 450	5 17/32	140.5	17/64	6.7	15 035	2 037
	15.70	EU 135		6	152.4	2 7/8	73.0	25 118 P	3 404	143.7	21/64	8.3	18 083	2 450	5 17/32	140.5	17/64	6.7	15 035	2 037
	16.60	IU 75		6	152.4	3	76.2	20 868 P	2 828	136.5	13/64	5.2	12 125	1 643	5 9/32	134.1	5/32	4.0	10 072	1 365
4 1/2	16.60	EU 75	4 1/2 FH NC46	6 1/4	158.8	3 1/4	82.6	20 396 P	2 764	137.3	13/64	5.2	12 085	1 638	5 11/32	135.7	11/64	4.4	10 647	1 443
	16.60	EU 75		5 7/8	149.2	3 3/4	95.3	16 346 P	2 215	138.1	13/64	5.2	11 862	1 607	5 3/8	136.5	11/64	4.4	10 375	1 406
	16.60	EU 75		6 5/8	168.3	3 3/4	95.3	22 836 P	3 094	145.3	5/32	4.0	11 590	1 570	5 11/16	144.5	9/64	3.6	10 773	1 460
4 1/2	16.60	EU 75	4 1/2 H-90	6	152.4	3 1/4	82.6	23 355 P	3 165	135.7	3/16	4.8	12 215	1 655	5 9/32	134.1	5/32	4.0	10 642	1 442
	16.60	EU 95		6	152.4	2 3/4	69.9	23 843 P	3 231	139.7	17/64	6.7	14 945	2 025	5 13/32	137.3	7/32	5.6	12 821	1 737
	16.60	EU 95		6 1/4	158.8	3 1/4	82.6	20 396 P	2 764	140.5	17/64	6.7	15 035	2 037	5 7/16	138.1	7/32	5.6	12 813	1 736
4 1/2	16.60	EU 95	NC50	6 5/8	168.3	3 3/4	95.3	22 836 P	3 094	148.4	7/32	5.6	14 926	2 022	5 25/32	146.8	3/16	4.8	13 245	1 795
	16.60	EU 95		6	152.4	3	76.2	27 091 P	3 671	138.9	1/4	6.4	15 441	2 092	5 3/8	136.5	13/64	5.2	13 102	1 775
	16.60	EU 105		6	152.4	2 3/4	69.9	23 843 P	3 231	141.3	19/64	7.5	16 391	2 221	5 15/32	138.9	1/4	6.4	14 231	1 928
4 1/2	16.60	EU 105	NC46	6 1/4	158.8	3	76.2	23 795 P	3 224	142.1	19/64	7.5	16 546	2 242	5 1/2	139.7	1/4	6.4	14 288	1 936
	16.60	EU 105		6 5/8	168.3	3 3/4	95.3	22 836 P	3 094	150.0	1/4	6.4	16 633	2 254	5 13/16	147.6	13/64	5.2	14 082	1 908
	16.60	EU 105		6	152.4	3	76.2	27 091 P	3 671	139.7	17/64	6.7	16 264	2 204	5 7/16	138.1	15/64	6.0	14 625	1 982

See notes at the end of B 23.

RECOMMENDED MINIMUM OD* AND MAKE-UP TORQUE OF WELD-ON TYPE TOOL JOINTS BASED ON TORSIONAL STRENGTH OF BOX AND DRILL PIPE (continued)

(API RP 7G, 15th edition, January 1, 1995)

Drill pipe			New tool joint data						Premium class						Class 2						
			Nominal size (in)	Nominal weight (lb/ft)	Type upset and grade	Connection	New OD		New ID	Make-up torque ⁶ (ft.lb)	Make-up torque ⁶ (daN.m)	Minimum OD tool joint		Minimum box shoulder with eccentric wear		Make-up torque for minimum OD tool joint (ft.lb)	Make-up torque for minimum OD tool joint (daN.m)	Minimum OD tool joint		Minimum box shoulder with eccentric wear	
(in)	(mm)	(in)					(mm)	(in)				(mm)	(in)	(mm)	(in)			(mm)	(in)	(mm)	(in)
4 1/2	16.60	IEU 135	NC46	6 1/4	158.8	2 3/4	69.9	26 923 P	3 648	146.8	5 25/32	25/64	9.9	21 230	2 877	143.7	5 21/32	21/64	8.3	18 083	2 450
	16.60	EU 135		6 5/8	168.3	3 1/2	88.9	27 076 P	3 669	154.0	6 1/16	21/64	8.3	21 017	2 848	151.6	5 31/32	9/32	7.1	18 367	2 489
4 1/2	20.00	IEU 75	4 1/2 FH	6	152.4	3	76.2	20 868 P	2 828	138.9	5 15/32	1/4	6.4	14 231	1 928	136.5	5 3/8	13/64	5.2	12 125	1 643
	20.00	EU 75		6 1/4	158.8	3	76.2	23 795 P	3 224	139.7	5 1/2	1/4	6.4	14 288	1 936	137.3	5 13/32	13/64	5.2	12 085	1 638
20.00	20.00	IEU 75	NC50	6 5/8	168.3	3 5/8	92.1	24 993 P	3 387	147.6	5 13/16	13/64	5.2	14 082	1 908	146.1	5 3/4	11/64	4.4	12 415	1 685
	20.00	EU 75		6	152.4	3	76.2	27 091 P	3 671	137.3	5 13/32	7/32	5.6	13 815	1 872	135.7	5 11/32	3/16	4.8	12 215	1 655
4 1/2	20.00	IEU 95	4 1/2 FH	6	152.4	2 1/2	63.5	26 559 P	3 599	142.9	5 5/8	21/64	8.3	17 861	2 420	140.5	5 17/32	9/32	7.1	15 665	2 123
	20.00	EU 95		6 1/4	158.8	2 3/4	69.9	26 923 P	3 648	143.7	5 21/32	21/64	8.3	18 083	2 450	141.3	5 9/16	9/32	7.1	15 787	2 139
20.00	20.00	IEU 95	NC50	6 5/8	168.3	3 1/2	88.9	27 076 P	3 669	150.8	5 15/16	17/64	6.7	17 497	2 371	149.2	5 7/8	15/64	6.0	15 776	2 138
	20.00	EU 95		6	152.4	3	76.2	27 091 P	3 671	141.3	5 9/16	19/64	7.5	17 929	2 429	138.9	5 15/32	1/4	6.4	15 441	2 092
4 1/2	20.00	IEU 105	NC46	6 1/4	158.8	2 1/2	63.5	29 778 P	4 035	145.3	5 23/32	23/64	9.1	19 644	2 662	142.9	5 5/8	5/16	7.9	17 311	2 346
	20.00	EU 105		6 5/8	168.3	3 1/2	88.9	27 076 P	3 669	153.2	6 1/32	5/16	7.9	20 127	2 727	150.0	5 29/32	1/4	6.4	16 633	2 254
4 1/2	20.00	EU 135	NC50	6 5/8	168.3	2 7/8	73.0	36 398 P	4 932	158.0	6 7/32	13/32	10.3	25 569	3 465	154.8	6 3/32	11/32	8.7	21 914	2 969
5	19.50	IEU 75	NC50	6 5/8	168.3	3 3/4	95.3	22 836 P	3 094	149.2	5 7/8	15/64	6.0	15 776	2 138	147.6	5 13/16	13/64	5.2	14 082	1 908
5	19.50	IEU 95	NC50	6 5/8	168.3	3 1/2	88.9	27 076 P	3 669	153.2	6 1/32	5/16	7.9	20 127	2 727	150.8	5 15/16	17/64	6.7	17 497	2 371
	19.50	EU 95		6 1/2	165.1	3 1/4	82.6	31 084 P	4 212	148.4	5 27/32	19/64	7.5	19 862	2 691	146.1	5 3/4	1/4	6.4	17 116	2 319
5	19.50	IEU 105	NC50	6 5/8	168.3	3 1/4	82.6	31 025 P	4 204	154.8	6 3/32	11/32	8.7	21 914	2 969	152.4	6	19/64	7.5	19 224	2 605
	19.50	EU 105		6 1/2	165.1	3	76.2	35 039 P	4 748	150.0	5 29/32	21/64	8.3	21 727	2 944	147.6	5 13/16	9/32	7.1	18 940	2 566
5	19.50	IEU 135	NC50	6 5/8	168.3	2 3/4	69.9	38 044 P	5 155	160.3	6 5/16	29/64	11.5	28 381	3 846	157.2	6 3/16	25/64	9.9	24 645	3 339
	19.50	EU 135		7 1/4	184.2	3 1/2	88.9	43 490 P	5 893	171.5	6 3/4	3/8	9.5	28 737	3 894	168.3	6 5/8	5/16	7.9	24 412	3 308
5	25.60	IEU 75	NC50	6 5/8	168.3	3 1/2	88.9	27 076 P	3 669	153.2	6 1/32	5/16	7.9	20 127	2 727	150.8	5 15/16	17/64	6.7	17 497	2 371
	25.60	EU 75		7	177.8	3 1/2	88.9	37 742 B	5 114	165.1	6 1/2	1/4	6.4	20 205	2 738	162.7	6 13/32	13/64	5.2	17 127	2 321
5	25.60	IEU 95	NC50	6 5/8	168.3	3	76.2	34 680 P	4 699	158.0	6 7/32	13/32	10.3	25 569	3 465	154.8	6 3/32	11/32	8.7	21 914	2 969
	25.60	EU 95		7	177.8	3 1/2	88.9	37 742 B	5 114	169.1	6 21/32	21/64	8.3	25 483	3 453	166.7	6 9/16	9/32	7.1	22 294	3 021
5	25.60	IEU 105	NC50	6 5/8	168.3	2 3/4	69.9	38 044 P	5 155	159.5	6 9/32	7/16	11.1	27 437	3 718	156.4	6 5/32	3/8	9.5	23 728	3 215
	25.60	EU 105		7 1/4	184.2	3 1/2	88.9	43 490 P	5 893	170.7	6 23/32	23/64	9.1	27 645	3 746	168.3	6 5/8	5/16	7.9	24 412	3 308

See notes at the end of B 23.

RECOMMENDED MINIMUM OD* AND MAKE-UP TORQUE OF WELD-ON TYPE TOOL JOINTS BASED ON TORSIONAL STRENGTH OF BOX AND DRILL PIPE (continued)

(API RP 7G, 15th edition, January 1, 1995)

Drill pipe		New tool joint data				Premium class						Class 2							
		New OD		New ID		Make-up torque ⁶		Minimum OD tool joint		Minimum box shoulder with eccentric wear		Minimum OD tool joint		Minimum box shoulder with eccentric wear		Make-up torque for minimum OD tool joint			
Nominal size	Nominal weight	(in)	(mm)	(in)	(mm)	(ft.lb)	(daN.m)	(in)	(mm)	(in)	(mm)	(in)	(mm)	(in)	(mm)	(ft.lb)	(daN.m)		
5	25.60	7 1/4	184.2	3 1/4	82.6	47 230 B	6 400	6 15/16	176.2	15/32	11.90	35 446	4 803	6 13/16	173.0	13/32	10.3	30 943	4 193
5 1/2	21.90	7	177.8	4	101.6	33 560 P	4 547	6 15/32	164.3	15/64	5.95	19 172	2 598	6 13/32	162.7	13/64	5.2	17 127	2 321
5 1/2	21.90	7	177.8	3 3/4	88.9	37 742 B	5 114	6 5/8	168.3	5/16	7.94	24 412	3 308	6 17/32	165.9	17/64	6.7	21 246	2 879
5 1/2	21.90	7	177.8	3 1/2	88.9	35 454 P	4 804	6 3/16	157.2	21/64	8.33	24 414	3 308	6 3/32	154.8	9/32	7.1	21 349	2 893
5 1/2	21.90	7 1/4	184.2	3 1/2	88.9	43 490 P	5 893	6 23/32	170.7	23/64	9.13	27 645	3 746	6 19/32	167.5	19/64	7.5	23 350	3 164
5 1/2	21.90	7 1/2	190.5	3	76.2	53 302 P	7 222	6 15/16	176.2	15/32	11.91	35 446	4 803	6 13/16	173.0	13/32	10.3	30 943	4 193
5 1/2	24.70	7	177.8	4	101.6	33 560 P	4 547	6 9/16	166.7	9/32	7.14	22 294	3 021	6 15/32	164.3	15/64	6.0	19 172	2 598
5 1/2	24.70	7 1/4	184.2	3 1/2	88.9	43 490 P	5 893	6 23/32	170.7	23/64	9.13	27 645	3 746	6 19/32	167.5	19/64	7.5	23 350	3 164
5 1/2	24.70	7 1/4	184.2	3 1/2	88.9	43 490 P	5 893	6 25/32	172.2	25/64	9.92	29 836	4 043	6 11/16	169.9	11/32	8.7	26 560	3 599
5 1/2	24.70	7 1/2	190.5	3	76.2	52 302 P	7 087	7 1/32	178.6	33/64	13.10	38 901	5 271	6 7/8	174.6	7/16	11.1	33 180	4 496
6 5/8	25.20	8	203.2	5	127.0	44 196 P	5 989	7 7/16	188.9	1/4	6.35	26 810	3 633	7 3/8	187.3	7/32	5.6	24 100	3 266
6 5/8	25.20	8	203.2	5	127.0	44 196 P	5 989	7 5/8	193.7	11/32	8.73	35 139	4 761	7 1/2	190.5	9/32	7.1	29 552	4 004
6 5/8	25.20	8 1/4	209.6	4 3/4	120.7	51 742 P	7 011	7 11/16	195.3	3/8	9.53	37 983	5 147	7 19/32	192.9	21/64	8.3	33 730	4 570
6 5/8	25.20	8 1/2	215.9	4 1/4	108.0	65 535 P	8 880	7 29/32	200.8	31/64	12.30	48 204	6 532	7 25/32	197.6	27/64	10.7	42 312	5 733
6 5/8	27.70	8	203.2	5	127.0	44 196 P	5 989	7 1/2	190.5	9/32	7.14	29 552	4 004	7 13/32	188.1	15/64	6.0	25 451	3 449
6 5/8	27.70	8 1/4	209.6	4 3/4	120.7	51 742 P	7 011	7 11/16	195.3	3/8	9.53	37 983	5 147	7 9/16	192.1	5/16	7.9	32 329	4 381
6 5/8	27.70	8 1/4	209.6	4 3/4	120.7	51 742 P	7 011	7 3/4	196.9	13/32	10.32	40 860	5 537	7 21/32	194.5	23/64	9.1	36 556	4 953
6 5/8	27.70	8 1/2	215.9	4 1/4	108.0	65 535 P	8 880	8	203.2	17/32	13.49	52 714	7 143	7 27/64	188.5	29/64	11.5	45 241	6 130

1. The use of outside diameters (OD) smaller than those listed in the table may be acceptable due to special service requirements.
2. Tool joint with dimensions shown has lower torsional yield ratio than the 0.80 which is generally used.
3. Recommended make-up torque is based on 72 000 psi stress.
4. In calculation of torsional strengths of tool joints, both new and worn, the bevels of the tool joint shoulders are disregarded. This thickness measurement should be made in the plane of the face from the ID of the counter bore to the outside diameter of the box, disregarding the bevels.
5. Any tool joint with an outside diameter less than API bevel diameter should be provided with a minimum 1/32" depth x 45° bevel on the outside and inside diameter of the box shoulder and outside diameter of the pin shoulder.
6. P = pin limit, B = Box limit.
- * Tool joint diameters specified are required to retain torsional strength in the tool joint comparable to the torsional strength of the attached drill pipe. These should be adequate for all service. Tool joints with torsional strengths considerably below that of the drill pipe may be adequate for much drilling service.

**THREAD DIMENSIONS OF ROTARY
SHOULDERED CONNECTIONS
(API Spec 7, 38th edition, April 1, 1994)**

(see Fig. B 25)

All dimensions in mm

Connection No. or size (1)	Thread form	Threads per inch	Taper (%)	Pitch diameter at gage point	Large pin diameter	Flat diameter on pin ± 0.40	Small pin diameter	Pin length + 0 - 3.18	Minimum length of box thread	Box counterbore + 9.52 - 0	Box inside diameter + 0.79 - 0.40
				C	D _L	D _{LF}	D _S	L _{PC}	L _{BT}	L _{BC}	Q _C
NC23	V-0.038R	4	16.66	59.8	65.1	61.9	52.4	76.2	79.4	92.1	66.7
NC26*	V-0.038R	4	16.66	67.8	73.1	69.8	60.4	76.2	79.4	92.1	74.6
NC31*	V-0.038R	4	16.66	80.8	86.1	83.0	71.3	88.9	92.1	104.8	87.7
NC35	V-0.038R	4	16.66	89.7	95.0	92.1	79.1	95.2	98.4	111.1	96.8
NC38*	V-0.038R	4	16.66	96.7	102.0	98.8	85.1	101.6	104.8	117.5	103.6
NC40*	V-0.038R	4	16.66	103.4	108.7	105.6	89.7	114.3	117.5	130.2	110.3
NC44	V-0.038R	4	16.66	112.2	117.5	114.3	98.4	114.3	117.5	130.2	119.1
NC46*	V-0.038R	4	16.66	117.5	122.8	119.6	103.7	114.3	117.5	130.2	124.6
NC50*	V-0.038R	4	16.66	128.1	133.4	130.4	114.3	114.3	117.5	130.2	134.9
NC56	V-0.038R	4	25.00	142.6	149.3	144.9	117.5	127.0	130.2	142.9	150.8
NC61	V-0.038R	4	25.00	156.9	163.5	159.2	128.6	139.7	142.9	155.6	165.1
NC70	V-0.038R	4	25.00	179.1	185.8	181.4	147.7	152.4	155.6	168.3	187.3
NC77	V-0.038R	4	25.00	196.6	203.2	198.8	162.0	165.1	168.3	181.0	204.8
2 3/8 REG	V-0.040	5	25.00	60.1	66.7	-	47.6	76.2	79.4	92.1	68.3
2 7/8 REG	V-0.040	5	25.00	69.6	76.2	-	54.0	88.9	92.1	104.8	77.8
3 1/2 REG	V-0.040	5	25.00	82.2	88.9	-	65.1	95.2	98.4	111.1	90.5
4 1/2 REG	V-0.040	5	25.00	110.9	117.5	-	90.5	108.0	111.1	123.8	119.1
5 1/2 REG	V-0.050	4	25.00	132.9	140.2	-	110.1	120.6	123.8	136.5	141.7
6 5/8 REG	V-0.050	4	16.66	146.2	152.2	-	131.0	127.0	130.2	142.9	154.0
7 5/8 REG	V-0.050	4	25.00	170.5	177.8	-	144.5	133.4	136.5	149.2	180.2
8 5/8 REG	V-0.050	4	25.00	194.7	202.0	-	167.8	136.5	139.7	152.4	204.4
5 1/2 FH	V-0.050	4	16.66	142.0	148.0	-	126.8	127.0	130.2	142.9	150.0
6 5/8 FH	V-0.050	4	16.66	165.6	171.5	-	150.4	127.0	130.2	142.9	173.9

(1) The NC connection No. is the pitch diameter in inches of the pin thread at the gage point (C), rounded off to units and tenths of an inch.

* NC connections are interchangeable with connections having the same pitch diameter in the FH and IF styles. These connections differ only in the form of the thread. Like the thread, the connections are interchangeable:

NC26	2 3/8 IF
NC31	2 7/8 IF
NC38	3 1/2 IF
NC40	4 FH
NC46	4 IF
NC50	4 1/2 IF

SHOULDERED CONNECTIONS

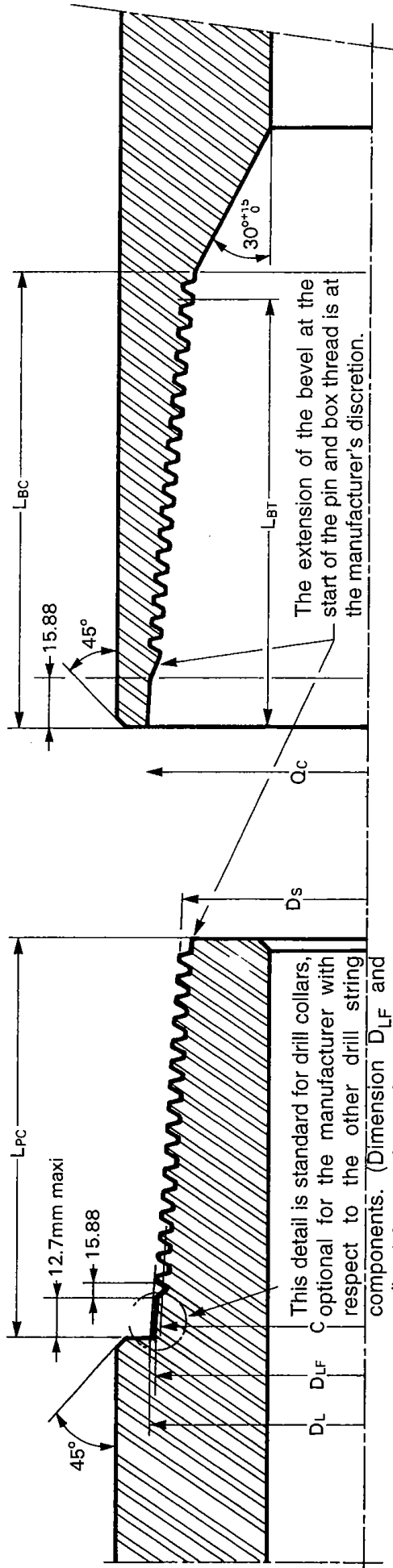

DIMENSIONS OF OBSOLETE SHOULDERED CONNECTIONS (API Spec 7, Appendix I)

(see Fig. B 25)

All dimensions in mm

Connection No. or size (1)	Thread form	Threads per inch	Taper (%)	Pitch diameter at gage point	Large pin diameter	Flat diameter on pin ± 0.40	Small pin diameter	Pin length $+ 0 - 3.18$	Minimum length of box thread	Box counterbore $+ 9.52 - 0$	Box inside diameter $+ 0.79 - 0.40$
				<i>C</i>	<i>D_L</i>	<i>D_{LF}</i>	<i>D_S</i>	<i>L_{PC}</i>	<i>L_{BT}</i>	<i>L_{BC}</i>	<i>Q_C</i>
3 1/2 FH	V-0.040	5	25.00	94.8	101.4	-	77.6	95.2	98.4	111.1	102.8
4 FH	V-0.040	4	16.66	103.4	108.7	105.6	89.7	114.3	117.5	130.2	110.3
4 1/2 FH	V-0.040	5	25.00	115.1	121.7	-	96.3	101.6	104.8	117.5	123.8
6 5/8 FH	V-0.040	4	16.66	165.6	171.5	-	150.4	127.0	130.2	142.9	173.8
2 3/8 IF	V-0.040	4	16.66	67.8	73.1	69.8	60.4	76.2	79.4	92.1	74.6
2 7/8 IF	V-0.040	4	16.66	80.8	86.1	83.0	71.3	88.9	92.1	104.8	87.7
3 1/2 IF	V-0.040	4	16.66	96.7	102.0	98.8	85.1	101.6	104.8	117.5	103.6
4 IF	V-0.040	4	16.66	117.5	122.8	119.6	103.7	114.3	117.5	130.2	124.6
4 1/2 IF	V-0.040	4	16.66	128.1	133.4	130.4	114.3	114.3	117.5	130.2	134.9
5 1/2 IF	V-0.040	4	16.66	157.2	162.5	-	141.3	127.0	130.2	142.9	163.9

mm \times 0.0394 = in

API THREAD FORMS AND DIMENSIONS (API Spec 7, 38th edition, April 1, 1994)

All dimensions in mm

Thread form	Taper (%)	Thread height not truncated	Thread height truncated	Root truncation	Crest truncation	Width of flat		Root radius	Radius at thread corners
		H	$h_n = h_s$	$S_{rn} = S_{rs}$ $f_{rn} = f_{rs}$	$f_{cn} = f_{cs}$	Crest	Root		
	(1)	H	$h_n = h_s$	$S_{rn} = S_{rs}$ $f_{rn} = f_{rs}$	$f_{cn} = f_{cs}$	$F_{cn} = F_{cs}$	$R_{rn} = F_{rs}$	$r_{rn} = r_{rs}$	r
V-0.038R	16.66	5.5	3.1	1.0	1.4	1.7	—	1.0	0.4
V-0.038R	25.00	5.5	3.1	1.0	1.4	1.7	—	1.0	0.4
V-0.040	25.00	4.4	3.0	0.5	0.9	1.0	—	0.5	0.4
V-0.050	25.00	5.5	3.7	0.6	1.1	1.3	—	0.6	0.4
V-0.050	16.66	5.5	3.8	0.6	1.1	1.3	—	0.6	0.4

(1) Taper (%) equal $8.33 \times$ taper in in/ft.

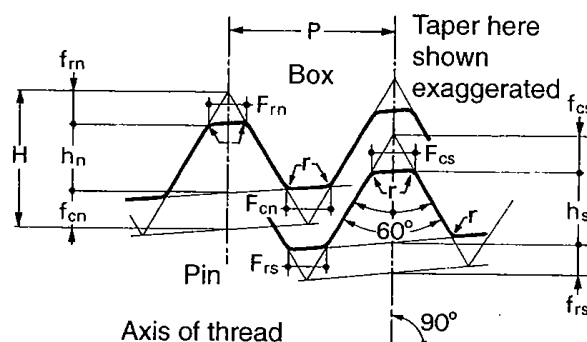
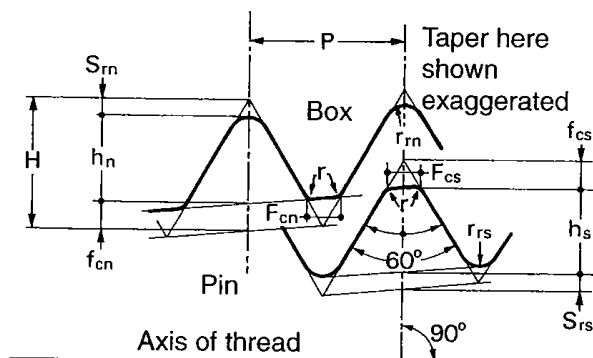
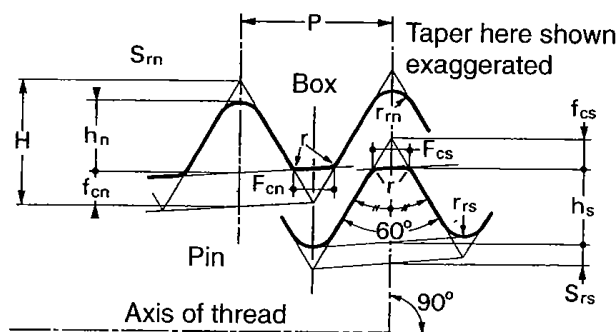

Obsolent. To be removed at a later date

mm \times 0.0394 = in

CHARACTERISTICS OF SOME NON-API TOOL JOINT THREADS

The dimensions in the tables below are given only to identify the type of thread. In particular, the joint outside and inside diameters, the diameter of the cylindrical part possibly turned at the base of the pin, and the lengths of the threaded parts, which differ, for the same shape, from one manufacturer to another, have not been indicated below.

Size (in)	Pin		Box Q_C (1) (mm)	Taper (%)	Threads per in	Thread form	Make-up torque (daN.m)
	D_{LF} (1) (mm)	C (mm)					
Extra Hole (XH) style							
2 7/8	84.5	79.2	85.3	16.66	4	V-0.065	760-950
3 1/2	96.8	91.5	98.4	16.66	4	V-0.065	975-1220
4 1/2	122.8	117.5	124.6	16.66	4	V-0.065	1950-2440
5	133.3	128.1	134.9	16.66	4	V-0.065	2140-2515
Double Streamline style							
3 1/2	84.5	79.2	85.3	16.66	4	V-0.065	570-705
4	98.7	93.4	99.6	16.66	4	V-0.065	870-1080
4 1/2	108.7	103.4	110.3	16.66	4	V-0.065	1060-1330
5 1/2	133.3	128.1	134.9	16.66	4	V-0.065	1900-2370
Slim Hole (SH) style							
2 7/8	73.1	67.8	74.6	16.66	4	V-0.065	390-490
3 1/2	86.1	80.8	87.7	16.66	4	V-0.065	650-800
4	96.8	91.5	98.4	16.66	4	V-0.065	870-1080
4 1/2	102.0	96.7	103.6	16.66	4	V-0.065	1060-1330
Hughes H90 style							
3 1/2	104.8	99.8	106.4	16.66	3 1/2	H90	1300-1630
4	114.3	109.3	115.9	16.66	3 1/2	H90	2000-2450
4 1/2	122.8	117.8	124.2	16.66	3 1/2	H90	2200-2700
Reed Wide Open (WO) style							
2 3/8	71.5	66.2	72.6	16.66	4	V-0.065	245-300
2 7/8	84.5	79.3	85.7	16.66	4	V-0.065	405-515
3 1/2	102.0	96.7	103.6	16.66	4	V-0.065	730-920
4	122.8	117.5	124.6	16.66	4	V-0.065	670-2050
4 1/2	133.3	128.1	134.9	16.66	4	V-0.065	900-2370

(1) Identical to those used to define the characteristics of API tool joints threads

mm × 0.0394 = in daN.m × 7.38 = lb.ft

CHARACTERISTICS OF SOME NON-API TOOL JOINT THREADS

(continued)

Size (in)	Pin		Box Q_C (1) (mm)	Taper (%)	Threads per in	Thread form	Make-up torque (daN.m)
	D_{LF} (1) (mm)	C (mm)					
American Open Hole (OH) style							
2 3/8	69.8	65.7	71.4	12.5	4	Special American	260–325
2 7/8	79.9	75.8	81.8	12.5	4		490–610
3 1/2	98.8	94.7	100.4	12.5	4		650–810
4	116.3	112.2	117.9	12.5	4		1520–1900
4 1/2	124.8	120.7	126.6	12.5	4		1170–1460

Size (in)	Pin		Taper (%)	Threads per in	Hybrid special thread	Make-up torque (daN.m)
	D_{LF} (1) (mm)	C (mm)				
Hydril IF style						
2 3/8	71.3	100.0	4.17	3	2 steps	515
2 7/8	80.8	100.0	4.17	3	2 steps	730
3 1/2	97.5	100.0	4.17	3	2 steps	895
4 1/2	132.1	100.6	4.17	3	2 steps	1550
Hydril EIU style						
3 1/2	95.0	107.9	4.17	3	2 steps	895
4	118.4	109.6	4.17	3	2 steps	1550
4 1/2	120.4	112.7	4.17	3	2 steps	1550
5 1/2	148.2	139.7	4.17	3	2 steps	2060
Hydril SH style						
2 7/8	71.3	100.0	4.17	3	2 steps	580
3 1/2	80.8	100.0	4.17	3	2 steps	730
4	97.5	100.0	4.17	3	2 steps	895
4 1/2	106.5	104.8	4.17	3	2 steps	1180
5 1/2	132.1	101.6	4.17	3	2 steps	1550
Hydril F style						
2 3/8	48.9	65.1	4.17	3	1 step	215
2 7/8	60.1	90.5	4.17	3	2 steps	365
3 1/2	71.3	101.6	4.17	3	2 steps	580
4	84.8	100.0	4.17	3	2 steps	730
4 1/2	97.5	100.0	4.17	3	2 steps	895
5 1/2	118.4	106.4	4.17	3	2 steps	1550

(1) Identical to those used to define the characteristics of API tool joints threads

mm \times 0.0394 = in daN.m \times 7.38 = lb.ft

**ROTARY SHOULDERS CONNECTION
INTERCHANGE LIST**

Common name		Pin base diameter tapered D_L (mm)	Threads per in	Taper %	Thread form (1)	Same as or interchanges with (2)
Style	Size					
Internal Flush (IF)	2 3/8	73.1	4	16.66	V-0.065 (V-0.038R)	2 7/8 Slim Hole NC26
	2 7/8	86.1	4	16.66	V-0.065 (V-0.038R)	3 1/2 Slim Hole NC31
	3 1/2	102.0	4	16.66	V-0.065 (V-0.038R)	4 1/2 Slim Hole NC38
	4	122.8	4	16.66	V-0.065 (V-0.038R)	4 1/2 Extra Hole NC46
	4 1/2	133.4	4	16.66	V-0.065 (V-0.038R)	5 Extra Hole NC50 5 1/2 Double Streamline
Full Hole (FH)	4	108.7	4	16.66	V-0.065 (V-0.038R)	4 1/2 Double Streamline NC40
Extra Hole (XH) EH	2 7/8	84.5	4	16.66	V-0.065 (V-0.038R)	3 1/2 Double Streamline
	3 1/2	96.8	4	16.66	V-0.065 (V-0.038R)	4 Slim Hole 4 1/2 External Flush
	4 1/2	122.8	4	16.66	V-0.065 (V-0.038R)	4 Internal Flush NC46
	5	133.4	4	16.66	V-0.065 (V-0.038R)	4 1/2 Internal Flush NC50 5 1/2 Double Streamline
Slim Hole (SH)	2 7/8	73.1	4	16.66	V-0.065 (V-0.038R)	2 3/8 Internal Flush NC31
	3 1/2	86.1	4	16.66	V-0.065 (V-0.038R)	2 7/8 Internal Flush NC31
	4	96.8	4	16.66	V-0.065 (V-0.038R)	3 1/2 Extra Hole 4 1/2 External Flush
	4 1/2	102.0	4	16.66	V-0.065 (V-0.038R)	3 1/2 Internal Flush NC38

(1) Connections with two thread form shown may be machined with either thread form without affecting gaging or interchangeability.

(2) Numbered connections (NC) may be machined only with the V-0.038 radius thread form.

mm × 0.0394 = in

ROTARY SHOULDERED CONNECTION INTERCHANGE LIST

(continued)

Common name		Pin base diameter tapered D_L (mm)	Threads per in	Taper %	Thread form (1)	Same as or interchanges with (2)
Style	Size					
Double Streamline (DSL)	3 1/2	84.5	4	16.66	V-0.065 (V-0.038R)	2 7/8 Extra Hole
	4 1/2	108.7	4	16.66	V-0.065 (V-0.038R)	4 Full Hole NC40
	5 1/2	133.4	4	16.66	V-0.065 (V-0.038R)	4 1/2 Internal Flush 5 Extra Hole NC50
Numbered connection (NC)	26	73.1	4	16.66	V-0.038R	2 3/8 Internal Flush 2 7/8 Slim Hole
	31	86.1	4	16.66	V-0.038R	2 7/8 Internal Flush 3 1/2 Slim Hole
	38	102.0	4	16.66	V-0.038R	3 1/2 Internal Flush 4 1/2 Slim Hole
	40	108.7	4	16.66	V-0.038R	4 Full Hole 4 1/2 Double Streamline
	46	122.8	4	16.66	V-0.038R	4 Internal Flush 4 1/2 Extra Hole
	50	133.4	4	16.66	V-0.038R	4 1/2 Internal Flush 5 Extra Hole 5 1/2 Double Streamline
External Flush (EF)	4 1/2	96.8	4	16.66	V-0.065 (V-0.038R)	4 Slim Hole 3 1/2 Extra Hole

(1) Connections with two threads forms shown may be machined with either thread form without affecting gaging or interchangeability.

(2) Numbered connections (NC) may be machined only with the V-0.038 radius form.

mm \times 0.0394 = in

CYLINDRICAL DRILL COLLARS

Dimensions and threads (API Spec 7)

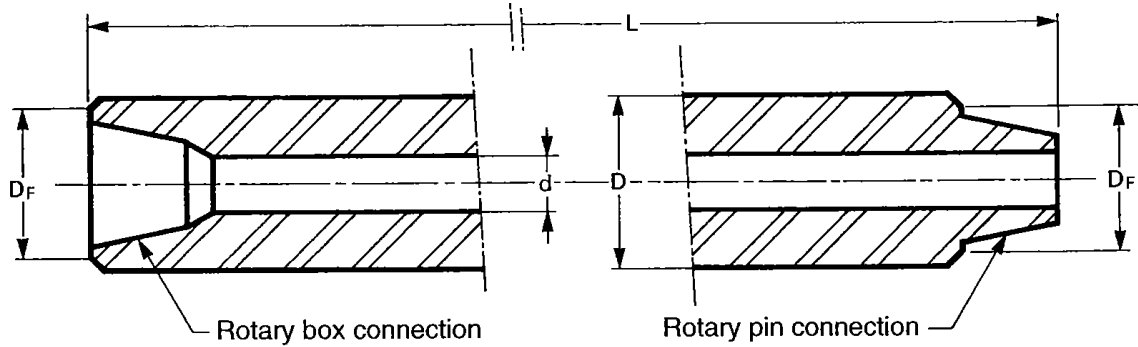

Drill collar No. (1)	Outside diameter D		Bore d		Length ± 0.15 L	Diameter at bevel $\pm 0.4 D_f$	BSR
	(in)	(mm)	+1/16 -0 (in)	+1/16 -0 (mm)	(m)	(mm)	
NC23-31	3 1/8	79.4	1 1/4	31.8	9.1	76.2	2.57
NC26-35 (2 3/8 IF)	3 1/2	88.9	1 1/2	38.1	9.1	82.9	2.42
NC31-41 (2 7/8 IF)	4 1/8	104.8	2	50.8	9.1	100.4	2.43
NC35-47	4 3/4	120.7	2	50.8	9.1	114.7	2.58
NC38-50 (3 1/2 IF)	5	127.0	2 1/4	57.2	9.1	121.0	2.38
NC44-60	6	152.4	2 1/4	57.2	9.1 or 9.4	144.5	2.49
NC44-60	6	152.4	2 13/16	71.4	9.1 or 9.4	144.5	2.84
NC44-62	6 1/4	158.8	2 1/4	57.2	9.1 or 9.4	149.2	2.91
NC46-62 (4 IF)	6 1/4	158.8	2 13/16	71.4	9.1 or 9.4	150.0	2.63
NC46-65 (4 IF)	6 1/2	165.1	2 1/4	57.2	9.1 or 9.4	154.8	2.76
NC46-65 (4 IF)	6 1/2	165.1	2 13/16	71.4	9.1 or 9.4	154.8	3.05
NC46-67 (4 IF)	6 3/4	171.5	2 1/4	57.2	9.1 or 9.4	159.5	3.18
NC50-70 (4 1/2 IF)	7	177.8	2 1/4	57.2	9.1 or 9.4	164.7	2.54
NC50-70 (4 1/2 IF)	7	177.8	2 13/16	71.4	9.1 or 9.4	164.7	2.73
NC50-72 (4 1/2 IF)	7 1/4	184.2	2 13/16	71.4	9.1 or 9.4	169.5	3.12
NC56-77	7 3/4	196.9	2 13/16	71.4	9.1 or 9.4	185.3	2.70
NC56-80	8	203.2	2 13/16	71.4	9.1 or 9.4	190.1	3.02
6 5/8 REG	8 1/4	209.6	2 13/16	71.4	9.1 or 9.4	195.7	2.93
NC61-90	9	228.6	2 13/16	71.4	9.1 or 9.4	212.7	3.17
7 5/8 REG	9 1/2	241.3	3	76.2	9.1 or 9.4	223.8	2.81
NC70-97	9 3/4	247.7	3	76.2	9.1 or 9.4	232.6	2.57
NC70-100	10	254.0	3	76.2	9.1 or 9.4	237.3	2.81
8 5/8 REG	11	279.4	3	76.2	9.1 or 9.4	266.7	2.84

(1) The drill collar number consists of two parts separated by a hyphen. The first part is the connection number in the NC style. The second part, consisting of 2 (or 3) digits, indicates the drill collar outside diameter in units and tenths of inches. The connections shown in parentheses in Col. 1 are not a part of the drill collar number; they indicate interchangeability of drill collars made with the standard (NC) connections as shown. If the connections shown in parentheses in column 1 are made with the V-0.038R thread form the connections, and drill collars, are identical with those in the NC style. Drill collars with 8 1/4 and 9 1/2 inches outside diameters are shown with 6 5/8 and 7 5/8 REG connections, since there are no NC connections in the recommended bending strength ratio range.

mm \times 0.0394 = in m \times 3.28 = ft

IDEAL DRILL COLLAR RANGE

Hole size	Casing size to be run	Ideal drill collar range		API drill collar sizes which fall in the ideal range
		Min	Max	
in				
6 1/8	4 1/2	3.875	4.750	4 1/8, 4 3/4
6 1/4	4 1/2	3.750	4.875	4 1/8, 4 3/4
6 3/4	4 1/2	3.250	5.125	3 1/2, 4 1/8, 4 3/4, 5
7 7/8	4 1/2	2.125	6.250	3 1/8, 3 1/2, 4 1/8, 4 3/4, 5, 6, 6 1/4
7 7/8	5 1/2	4.225	6.250	4 3/4, 5, 6, 6 1/4
8 3/8	5 1/2	3.725	6.750	4 1/8, 4 3/4, 5, 6, 6 1/4, 6 1/2, 6 3/4
8 3/8	6 5/8	6.405	6.750	6 1/2, 6 3/4
8 1/2	6 5/8	6.280	6.750	6 1/2, 6 3/4
8 1/2	7	-	6.750	6 3/4
8 3/4	6 5/8	6.030	7.125	6 1/4, 6 1/2, 6 3/4, 7
8 3/4	7	6.562	7.125	6 3/4, 7
9 1/2	7	6.812	7.625	6, 6 1/4, 6 1/2, 6 3/4, 7, 7 1/4
9 1/2	7 5/8	7.500	7.875	7 3/4
9 7/8	7	5.437	8.000	6, 6 1/4, 6 1/2, 6 3/4, 7, 7 1/4, 7 3/4, 8
9 7/8	7 5/8	7.125	8.000	7 1/4, 7 3/4, 8
10 5/8	7 5/8	6.375	8.500	6 1/2, 6 3/4, 7, 7 1/4, 7 3/4, 8, 8 1/4
10 5/8	8 5/8	-	8.500	8 1/4
11	8 5/8	8.250	8.875	8 1/4
12 1/4	9 5/8	9.000	10.125	9, 9 1/2, 9 3/4, 10
12 1/4	10 3/4	-	10.125	10
13 3/4	10 3/4	9.750	11.250	9 3/4, 10, 11
14 3/4	11 3/4	10.750	12.000	11, *12
17 1/2	13 3/8	11.250	13.375	*12
20	16	14.000	14.750	*14
24	18 5/8	15.500	16.750	*16
26	20	16.000	19.500	*16

The minimum size drill-collar is calculated from the Lubinski and Hock equation.

* Not API standard size drill collar.

WEIGHT OF DRILL COLLARS (kg/m)

OD		Inside diameter (in and mm)														
		1	1 1/4	1 1/2	1 3/4	2	2 1/4	2 1/2	2 3/4	2 4/5	2 7/8	3	3 1/4	3 1/2	3 3/4	4
in	mm															
2 7/8	73.03	25.40	31.75	38.10	44.45	50.80	57.15	63.50	69.85	71.44	73.03	76.20	82.55	88.90	95.25	101.60
3	76.20	28.90	26.66	23.93												
3 1/8	79.38	31.82	29.58	26.85												
3 1/4	82.55	34.87	32.63	29.89												
3 1/2	88.90	44.75	35.80	33.06												
3 3/4	95.25	51.96	42.51	39.78	43.75											
4	101.60	59.66	49.72	46.99												
4 1/8	104.78	63.70	57.43	54.69	51.46	47.73	43.51									
4 1/4	107.95	67.87	61.47	58.73	55.50	51.77	47.55									
4 1/2	114.30	76.57	65.63	62.90	59.66	55.94	51.71									
4 3/4	120.65	85.77	74.33	71.60	68.37	64.64	60.41	64.89								
5	127.00	95.46	83.53	80.80	77.56	73.84	69.61									
5 1/4	133.35	105.66		90.49	87.26	83.53	79.30	74.58	69.36							
5 1/2	139.70	116.35		100.68	97.45	93.72	89.50	84.77	79.55	78.17	76.76	73.84				
5 3/4	146.05	127.53		111.37	108.14	104.41	100.19	95.46	90.24	88.86	87.45	84.53	89.50			
6	152.40	139.22		122.56	119.33	115.60	111.37	106.65	101.43	100.05	98.63	95.71				
6 1/4	158.75	151.40		134.25	131.01	127.28	123.06	118.34	113.11	111.73	110.32	107.40	101.18	94.47	87.26	
6 3/8	161.93	157.68		146.43	143.20	139.47	135.24	130.52	125.30	123.91	122.50	119.58	113.36	106.65	99.44	
6 1/2	165.10	164.08		152.70	149.47	145.74	141.52	136.79	131.57	130.19	128.78	125.86	119.64	112.93	105.72	
6 5/8	168.28	170.60		159.11	155.87	152.15	147.92	143.20	137.97	136.59	135.18	132.26	126.04	119.33	112.12	
6 3/4	171.45	177.25		165.63	162.40	158.67	154.44	149.72	144.50	143.12	141.70	138.78	132.57	125.86	118.65	
				172.28	169.05	165.32	161.09	156.37	151.15	149.77	148.35	145.43	139.22	132.51	125.30	117.59
7	177.80	190.93		185.96	182.72	178.99	174.77	170.04	164.82	163.44	162.03	159.11	152.89	146.18	138.97	131.26
7 1/4	184.15	205.10		200.13	196.89	193.16	188.94	184.22	178.99	177.61	176.20	173.28	167.06	160.35	153.14	145.43
7 1/2	190.50	219.77		214.79	211.56	207.83	203.61	198.88	193.66	192.28	190.87	187.94	181.73	175.02	167.81	160.10
7 3/4	196.85	234.93		229.96	226.73	223.00	218.77	214.05	208.83	207.44	206.03	203.11	196.89	190.18	182.97	175.27
8	203.20	250.59		245.62	242.39	238.66	234.43	229.71	224.49	223.11	221.69	218.77	212.56	205.84	198.63	190.93
8 1/4	209.55	266.75		261.78	258.55	254.82	250.59	245.87	240.65	239.27	237.85	234.93	228.72	222.00	214.79	207.09
8 1/2	215.90	283.41		278.44	275.20	271.47	267.25	262.53	257.30	255.92	254.51	251.59	245.37	238.66	231.45	223.74
8 3/4	222.25	300.56		295.59	292.36	288.63	284.40	279.68	274.46	273.08	271.66	268.74	262.53	255.81	248.60	240.90
9 1/4	234.95	336.36			328.16	324.43	320.20	315.48	310.26	308.87	307.46	304.54	298.32	291.61	284.40	276.70
9 1/2	241.30	355.01			346.80	343.07	338.85	334.12	328.90	327.52	326.11	323.18	316.97	310.26	303.05	295.34
9 3/4	247.65	374.15			365.94	362.22	357.99	353.27	348.04	346.66	345.25	342.33	336.11	329.40	322.19	314.48
10	254.00	393.79				381.85	377.63	372.91	367.68	366.30	364.89	361.97	355.75	349.04	341.83	334.12
10 1/2	266.70	434.56				422.63	418.40	413.68	408.46	407.07	405.66	402.74	396.52	389.81	382.60	374.89
10 3/4	273.05	455.69				443.76	439.53	434.81	429.59	428.20	426.79	423.87	417.65	410.94	403.73	396.03
11	279.40	477.32						456.44	451.22	449.83	448.42	445.50	439.28	432.57	425.36	417.65
11 1/4	285.75	499.44						478.56	473.34	471.96	470.54	467.62	461.41	454.70	447.49	439.78
12	304.80	568.80						547.92	542.70	541.32	539.90	536.98	530.77	524.06	516.85	509.14
14	355.60	775.64							749.54	748.16	746.74	743.82	737.61	730.89	723.68	715.98

DRILL COLLAR ASSEMBLY RIGIDITY *R*

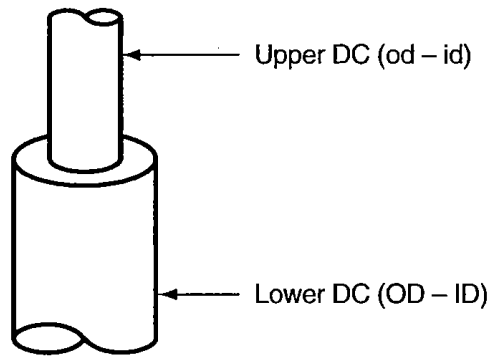

$$R = \frac{E_1 \times \text{Lower DC polar modulus}}{E_2 \times \text{Upper DC polar modulus}} = \frac{id}{OD} \times \frac{OD^4 - ID^4}{od^4 - id^4}$$

E = Young's modulus of material

$$\frac{I_0}{V} = \text{Polar modulus} = \frac{\pi}{16} \frac{OD^4 - ID^4}{OD}$$

Drilco recommendation: $R \leq 5.5$

Flexion stress at yield *Y* (psi): *t*

$$t = \frac{Y I_0}{2 V} = Y \frac{OD^4 - id^4}{122.23 \times OD}$$

Lower DC (in)	Upper DC	<i>R</i>
11 × 3	9 1/2 × 3	1.6
	8 1/2 × 2 13/16	2.2
	7 1/4 × 2 13/16	3.5
	6 1/2 × 2 13/16	5.0
9 1/2 × 3	8 1/2 × 2 13/16	1.4
	7 1/4 × 2 13/16	2.3
	6 1/2 × 2 13/16	3.2
8 1/4 × 2 13/16	7 1/4 × 2 13/16	1.5
	6 1/2 × 2 13/16	2.1
	HW 5 × 3	5.1
8 × 2 13/16	7 1/4 × 2 13/16	1.4
	6 1/2 × 2 13/16	1.9
	HW 5 × 3	4.6
7 1/4 × 2 13/16	6 1/2 × 2 13/16	1.4
	HW 5 × 3	3.4
6 1/2 × 2 13/16	HW 5 × 3	2.4
	DPS × 4.276	4.6
HW 5 × 3	DPS × 4.276	1.9
4 3/4 × 2 1/4	3 1/2 × 2.764	3.9

STRESS-RELIEF FEATURES FOR DRILL COLLAR CONNECTIONS (API Spec 7)

Number of size and style of connection	Length shoulder face to groove of box member L_x (1)		Diameter of pin member at groove D_{RG} (2)	
	(mm)	(in)	(mm)	(in)
NC35	85.7	3 3/8	82.2	3 15/64
NC38 (3 1/2 IF)	92.1	3 5/8	89.3	3 33/64
NC40 (4 FH)	104.8	4 1/8	96.0	3 25/32
NC44	104.8	4 1/8	106.4	4 3/16
NC46 (4 IF)	104.8	4 1/8	109.9	4 21/64
NC50 (4 1/2 IF)	104.8	4 1/8	120.7	4 3/4
NC56	117.5	4 5/8	134.5	5 19/64
NC61	130.2	5 1/8	148.8	5 55/64
NC70	142.9	5 5/8	171.1	6 47/64
NC77	155.6	6 1/8	188.5	7 27/64
4 1/2 FH	92.1	3 5/8	106.8	4 13/64
5 1/2 REG	111.1	4 3/8	123.4	4 55/64
6 5/8 REG	117.5	4 5/8	137.7	5 27/64
7 5/8 REG	123.8	4 7/8	162.7	6 13/32
8 5/8 REG	123.8	4 7/8	184.9	7 18/64

(1) Tol + 0 - 3.2 mm (+ 0 - 1/8")

(2) Tol + 0 - 0.8 mm (+ 0 - 1/32")

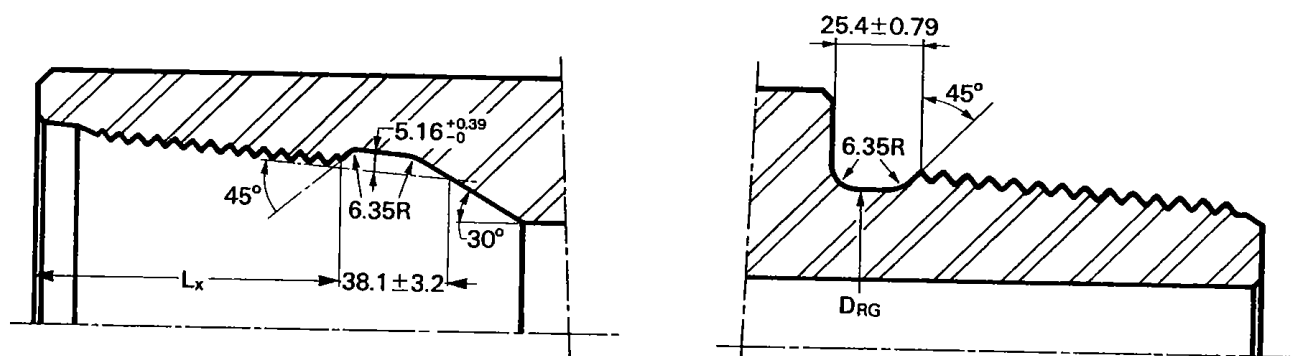

Remarks:

Dimensions in mm.

Connections NC23, NC26 and NC31 (2 3/8 IF and 2 7/8 IF) do not have a sufficient metal to accommodate stress-relief features.

LARGE-DIAMETER DRILL COLLARS FROM 8 3/4 TO 11 1/4 INCHES SHOULDER MODIFICATIONS FOR LOW-TORQUE CONNECTIONS

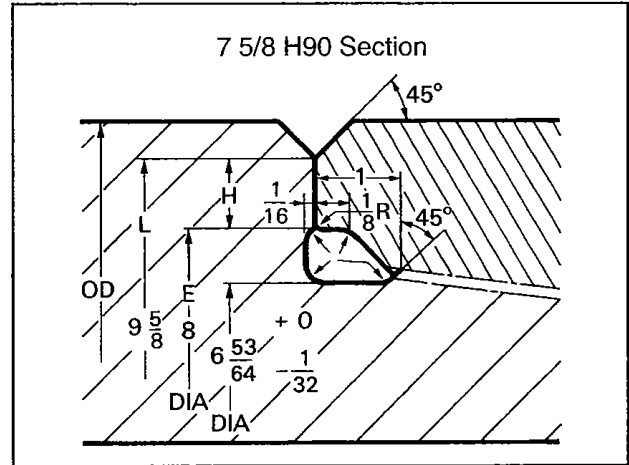
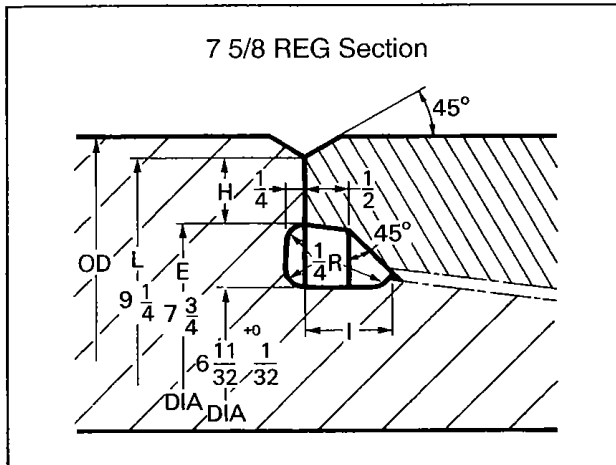

DIMENSIONS OF LOW-TORQUE SHOULDERED

Connection size and style	Outside diameter OD	Bevel diameter L		Inside diameter of shouldered E		Width of flat H N: normal R: modified		
	(in)	(in)	(mm)	(in)	(mm)	(in)	(mm)	
7 H 90	8 1/4	8	203.2	6 9/16	166.7	23/32	18.26	N
	8 1/2	8 1/4	209.6	6 9/16	166.7	27/32	21.43	N
	8 3/4	8 1/2	215.9	7 1/8	181.0	11/16	17.46	R
	9	8 5/8	219.1	7 1/8	181.0	3/4	19.05	R
7 H 90	9 1/2	9 1/4	235.0	7 29/64	189.3	57/64	22.62	N
	9 3/4	9 1/4	235.0	8	203.2	5/8	15.88	R
	10	9 5/8	244.5	8	203.2	13/16	20.64	R
	10 1/4	9 5/8	244.5	8	203.2	13/16	20.64	R
7 5/8 REG	9 1/2	8 7/8	225.4	7 3/32	180.2	57/64	22.62	N
	9 3/4	9 1/4	235.0	7 3/4	196.9	3/4	19.05	R
	10	9 1/4	235.0	7 3/4	196.9	3/4	19.05	R
8 5/8 H 90	10 1/2	10 3/8	263.5	8 11/32	211.9	11/64	25.80	N
	10 3/4	10 1/2	266.7	9 3/8	238.1	9/16	14.29	R
	11	10 1/2	266.7	9 3/8	238.1	9/16	14.29	R
	11 1/4	10 3/4	273.1	9 3/8	238.1	11/16	17.46	R
8 5/8 REG	10 1/2	9 3/4	247.7	8 1/16	204.8	27/32	21.43	N
	10 3/4	11 1/2	292.1	9	228.6	3/4	19.05	R
	11	10 1/2	266.7	9	228.6	3/4	19.05	R

SPIRAL DRILL COLLARS (Drilco)

Cross section for drill collars 3 7/8" to 7"	Size OD (in)	Depth of cut e (mm)	Number of spirals	Direction	Pitch (mm)	Length of cylindrical end			
						Pin end (mm)		Box end (mm)	
						Mini	Maxi	Mini	Maxi
	3 7/8	1.98 ± 0.79	3	To the right	914.4 ± 25.4				
	4 to 4 3/8	4.76 ± 0.79	3	To the right	914.4 ± 25.4				
	4 1/2 to 5 1/8	5.56 ± 0.79	3	To the right	965.2 ± 25.4				
	5 1/4 to 5 3/4	6.35 ± 0.79	3	To the right	1066.8 ± 25.4	340.8	457.2	609.6	
	5 7/8 to 6 3/8	7.14 ± 1.59	3	To the right	1066.8 ± 25.4				
	6 1/2 to 7	7.14 ± 1.59	3	To the right	1168.4 ± 25.4				
	7	7.94 ± 1.59							
		7 1/8 to 7 7/8	8.73 ± 1.59	3	To the right	1625.6 ± 25.4			
		8 to 8 7/8	9.53 ± 1.59	3	To the right	1727.2 ± 25.4			
		9 to 9 7/8	10.32 ± 2.38	3	To the right	1828.8 ± 25.4			
10 to 10 7/8		11.11 ± 2.38	3	To the right	1930.4 ± 25.4	304.8	457.2	609.6	
11 to 12		11.91 ± 2.38	3	To the right	2032.0 ± 25.4				

Note: the weight of a spiral drill-collar will be reduced approximately of 4%.
mm x 0.0394 = in

**DRILL COLLAR SLIP AND ELEVATOR RECESS
ELEVATOR BORE DIMENSIONS
(API RP 7G, 15th edition, January 1, 1995)**

Drill collar OD range (in)	Dimensions					Elevator bore	
	Elevator			Slip		Top bore (3) + 0 - 1 (mm)	Bottom bore (3) + 2 - 0 (mm)
	A (1) (mm)	R (mm)	C (2) (°)	B (1) (mm)	D (2) (°)		
4 to 4 5/8	5.6	3.2	4	4.8	3.5	OD - 7.9	OD + 3.2
4 3/4 to 5 5/8	6.4	3.2	5	4.8	3.5	OD - 9.5	OD + 3.2
5 3/4 to 6 5/8	7.9	3.2	6	6.4	5	OD - 12.7	OD + 3.2
6 3/4 to 8 5/8	9.5	4.8	7.5	6.4	5	OD - 14	OD + 3.2
8 3/4 and up	11.1	6.4	9	6.4	5	OD - 15.9	OD + 3.2

- (1) A and B dimensions are from nominal OD of new drill collar.
- (2) Angle C and D dimensions are reference and approximate.
- (3) OD is the outside diameter in millimeters of the new drill collar.

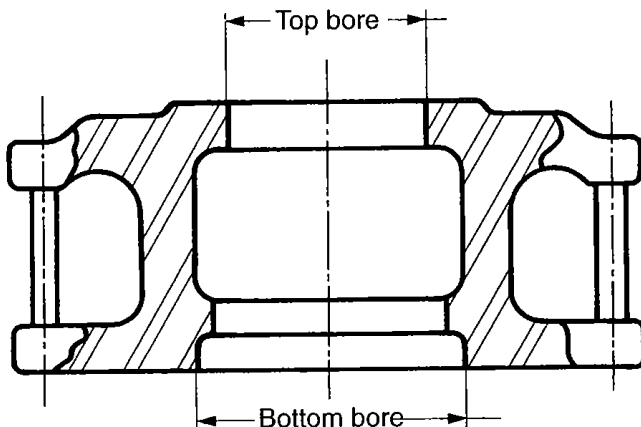
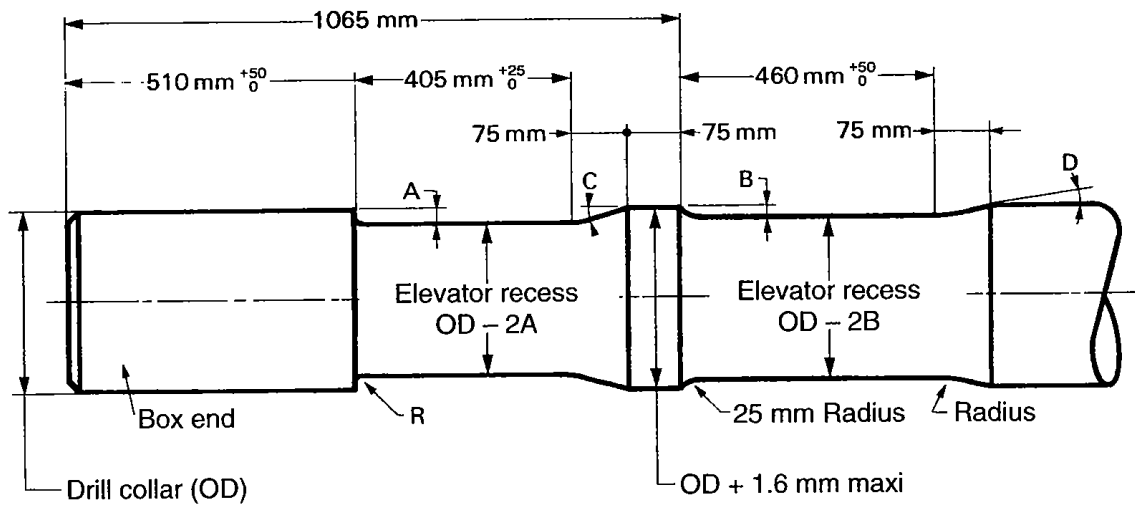

Drill collar elevator

Note : These dimensions must not be used as API Standards.

mm × 0.0394 = in

RECOMMENDED MAKE-UP TORQUE¹ FOR ROTARY SHOULDERED DRILL COLLAR CONNECTIONS (API RP 7G, 15th edition, January 1, 1995)

Size		Connection		Minimum make-up torque														
				Bore of drill collars														
				1		1 1/4		1 1/2		1 3/4		2		2 1/4		2 1/2		
(in)		(in)	(mm)	(ft.lb)	(daN.m)	(ft.lb)	(daN.m)	(ft.lb)	(daN.m)	(ft.lb)	(daN.m)	(ft.lb)	(daN.m)	(ft.lb)	(daN.m)	(ft.lb)	(daN.m)	
API	NC23	3	76.2	*2 508	340	*2 508	340	340	*2 508	340	340	340	340	340	340	340	340	340
		3 1/8	79.4	*3 330	451	2 647	451	451	2 647	451	451	451	451	451	451	451	451	451
		3 1/4	82.6	4 000	542	2 647	459	359	2 647	459	359	359	359	359	359	359	359	359
2 3/8	Regular	3	76.2	*2 241	304	*2 241	304	304	*2 241	304	304	304	304	304	304	304	304	304
		3 1/8	79.4	*3 028	410	2 574	349	349	2 574	410	349	349	349	349	349	349	349	349
		3 1/4	82.6	3 285	445	2 574	349	349	2 574	445	349	349	349	349	349	349	349	349
2 7/8	PAC ³	3	76.2	*3 797	514	*3 797	514	514	*3 797	514	514	514	514	514	514	514	514	514
		3 1/8	79.4	*4 966	673	4 151	562	562	4 151	673	562	562	562	562	562	562	562	562
		3 1/4	82.6	5 206	705	4 151	562	562	4 151	705	562	562	562	562	562	562	562	562
2 3/8	API IF	3	88.9	*4 606	624	*4 606	624	624	*4 606	624	624	624	624	624	624	624	624	624
API	NC26	3 3/4	95.3	5 501	745	4 668	633	633	4 668	745	633	633	633	633	633	633	633	633
2 7/8	Regular	3	88.9	*3 838	520	*3 838	520	520	*3 838	520	520	520	520	520	520	520	520	520
		3 3/4	95.3	5 766	781	4 951	671	671	4 951	781	671	671	671	671	671	671	671	671
		3 7/8	98.4	5 766	781	4 951	671	671	4 951	781	671	671	671	671	671	671	671	671
2 7/8	Extra Hole	3	95.3	*4 089	554	*4 089	554	554	*4 089	554	554	554	554	554	554	554	554	554
3 1/2	Dbt. Streamline	3 7/8	98.4	*5 352	725	*5 352	725	725	*5 352	725	725	725	725	725	725	725	725	725
2 7/8	Mod. Open	4 1/8	104.8	*8 059	1 092	*8 059	1 092	1 092	*8 059	1 092	1 092	1 092	1 092	1 092	1 092	1 092	1 092	1 092
2 7/8	API IF	3 7/8	98.4	*4 640	629	*4 640	629	629	*4 640	629	629	629	629	629	629	629	629	629
API	NC31	4 1/8	104.8	*7 390	1 001	*7 390	1 001	1 001	*7 390	1 001	1 001	1 001	1 001	1 001	1 001	1 001	1 001	1 001
3 1/2	Regular	4 1/8	104.8	*6 466	876	*6 466	876	876	*6 466	876	876	876	876	876	876	876	876	876
		4 1/4	108.0	*7 886	1 069	*7 886	1 069	1 069	*7 886	1 069	1 069	1 069	1 069	1 069	1 069	1 069	1 069	1 069
		4 1/2	114.3	10 471	1 419	9 514	1 289	1 289	9 514	1 419	1 289	1 289	1 289	1 289	1 289	1 289	1 289	1 289
3 1/2	Slim Hole	4 1/4	108.0	*8 858	1 200	*8 858	1 200	1 200	*8 858	1 200	1 200	1 200	1 200	1 200	1 200	1 200	1 200	1 200
		4 1/2	114.3	10 286	1 394	10 286	1 394	1 394	10 286	1 394	1 394	1 394	1 394	1 394	1 394	1 394	1 394	1 394
API	NC35	4 1/2	114.3	*9 038	1 225	*9 038	1 225	1 225	*9 038	1 225	1 225	1 225	1 225	1 225	1 225	1 225	1 225	1 225
		4 3/4	120.7	12 273	1 663	12 273	1 663	1 663	12 273	1 663	1 663	1 663	1 663	1 663	1 663	1 663	1 663	1 663
		5	127.0	12 273	1 663	12 273	1 663	1 663	12 273	1 663	1 663	1 663	1 663	1 663	1 663	1 663	1 663	1 663
3 1/2	Extra Hole	4 1/4	108.0	*5 161	699	*5 161	699	699	*5 161	699	699	699	699	699	699	699	699	699
4	Slim Hole	4 1/2	114.3	*8 479	1 149	*8 479	1 149	1 149	*8 479	1 149	1 149	1 149	1 149	1 149	1 149	1 149	1 149	1 149
3 1/2	Mod. Open	4 3/4	120.7	*12 074	1 636	*12 074	1 636	1 636	*12 074	1 636	1 636	1 636	1 636	1 636	1 636	1 636	1 636	1 636
		5	127.0	13 283	1 800	13 283	1 800	1 800	13 283	1 800	1 800	1 800	1 800	1 800	1 800	1 800	1 800	1 800
		5 1/4	133.4	13 283	1 800	13 283	1 800	1 800	13 283	1 800	1 800	1 800	1 800	1 800	1 800	1 800	1 800	1 800

See notes at the end of B 46.

RECOMMENDED MAKE-UP TORQUE¹ FOR ROTARY SHOULDERED DRILL COLLAR CONNECTIONS (continued) (API RP 7G, 15th edition, January 1, 1995)

Connection		Minimum make-up torque																																													
		Bore of drill collars																																													
		2 1/2		2 1/4		2		1 3/4		2 1/2		2 13/16		3																																	
Size (in)	Type	OD (in)	OD (mm)	(ft.lb)	(daN.m)	(ft.lb)	(daN.m)	(ft.lb)	(daN.m)	(ft.lb)	(daN.m)	(ft.lb)	(daN.m)	(ft.lb)	(daN.m)																																
3 1/2 API 4 1/2	API IF NC38 Slim Hole	4 3/4 5 5 1/4 5 1/2	120.7 127.0 133.4 139.7	*9 986 *13 949 14 643 16 207	1 353 1 890 2 196 2 196	*9 986 *13 949 14 643 14 643	1 353 1 890 1 984 1 984	*9 986 12 907 12 907 12 907	1 353 1 749 1 749 1 749	*9 986 10 977 10 977 10 977	1 353 1 487 1 487 1 487	8 315 8 315 8 315 8 315	1 127 1 127 1 127 1 127	1 127 1 127 1 127 1 127																																	
																	3 1/2	H-90 ⁴	4 3/4 5 5 1/4 5 1/2	120.7 127.0 133.4 139.7	*8 786 *12 794 *17 094 18 522	1 191 1 734 2 316 2 510	*8 786 *12 794 *17 094 18 522	1 191 1 734 2 051 2 051	*8 786 *12 794 13 151 13 151	1 191 1 734 2 051 1 782	*8 786 10 408 10 408 10 408	1 191 1 410 1 410 1 410	1 191 1 410 1 410 1 410																		
																																4 API 4 4 1/2	Full Hole NC40 Mod. Open Dbl. Streamline	5 5 1/4 5 1/2 5 3/4 6	127.0 133.4 139.7 146.1 152.4	*10 910 *15 290 *19 985 20 539 20 539	1 478 2 072 2 708 2 783 2 783	*10 910 *15 290 18 886 18 886 18 886	1 478 2 072 2 307 2 307 2 307	*10 910 14 969 14 969 14 969 14 969	1 478 2 028 2 028 2 028 2 028	*10 910 12 125 12 125 12 125 12 125	1 478 1 643 1 643 1 643 1 643	1 478 1 706 2 241 2 241 2 241	1 478 1 706 2 241 2 241 2 241		
API	NC44	5 3/4 6 6 1/4 6 1/2	146.1 152.4 158.8 165.1	*20 895 *26 453 27 300 27 300	2 831 3 584 3 699 3 699	*20 895 25 510 25 510 25 510	2 831 3 183 3 183 3 183	*20 895 21 257 21 257 21 257	2 831 2 880 2 880 2 880	18 161 18 161 18 161 18 161	2 461 2 461 2 461 2 461	2 461 2 461 2 461 2 461																																			
															4 1/2	API Full Hole	5 1/2 5 3/4 6 6 1/4 6 1/2	139.7 146.1 152.4 158.8 165.1	*12 973 *18 119 *23 605 27 294 27 294	1 758 2 455 3 199 3 698 3 698	*12 973 *18 119 *23 605 25 272 25 272	1 758 2 455 3 199 3 424 3 424	*12 973 *18 119 23 028 22 028 22 028	1 758 2 455 3 120 2 985 2 985	*12 973 *18 119 19 921 19 921 19 921	1 758 2 455 2 699 2 699 2 699	1 758 2 455 2 699 2 699 2 699	1 758 2 425 2 425 2 425 2 425																			
																															4 1/2 API 4 4 1/2 5	Extra Hole NC46 API IF Semi IF Dbl. Streamline	5 3/4 6 6 1/4 6 1/2 6 3/4	146.1 152.4 158.8 165.1 171.5	*17 738 *23 422 28 021 28 021 28 021	*17 738 *23 422 28 021 28 021 28 021	2 404 3 174 3 797 3 797 3 797	*17 738 *23 422 25 676 25 676 25 676	2 404 3 174 3 479 3 479 3 479	*17 738 22 426 22 426 22 426 22 426	*17 738 20 311 20 311 20 311 20 311	2 404 3 039 3 039 3 039 3 039	2 404 2 752 2 752 2 752 2 752	2 404 2 752 2 752 2 752 2 752			

See notes at the end of B 46.

**RECOMMENDED MAKE-UP TORQUE¹
FOR ROTARY SHOULDERED DRILL COLLAR CONNECTIONS (continued)
(API RP 7G, 15th edition, January 1, 1995)**

Size (in)		Connection Type		OD (in) (mm)		Minimum make-up torque											
						Bore of drill collars											
						2 1/4		2 1/2		2 13/16		3		3 1/4		3 1/2	
		(ft.lb)	(daN.m)	(ft.lb)	(daN.m)	(ft.lb)	(daN.m)	(ft.lb)	(daN.m)	(ft.lb)	(daN.m)	(ft.lb)	(daN.m)	(ft.lb)	(daN.m)		
4 1/2	H-90 ⁴	5 3/4	146.1	*18 019	2 442	*18 019	2 442	*18 019	2 442	*18 019	2 442	*18 019	2 442				
		6	152.4	*23 681	3 209	3 138	23 159	3 138	21 051	2 852							
		6 1/4	158.8	28 732	3 893	3 577	26 397	3 577	21 051	2 852							
		6 1/2	165.1	28 732	3 893	3 577	26 397	3 577	21 051	2 852							
5	H-90 ⁴	6 3/4	171.5	28 732	3 893	3 577	26 397	3 577	21 051	2 852							
		7	177.8	35 292	4 782	32 825	29 400	3 984	27 167	3 681	23 988	3 250					
		7 1/4	184.2	35 292	4 782	32 825	29 400	3 984	27 167	3 681	23 988	3 250					
		7 1/2	190.5	38 379	5 200	35 824	32 277	4 374	29 966	4 060	26 675	3 614					
4 1/2 API	API IF NC50 Extra Hole	6 1/4	158.8	*23 004	3 117	*23 004	3 117	*23 004	3 117	*23 004	3 117	*23 004	3 117				
		6 1/2	165.1	*29 679	4 022	*29 679	4 022	*29 679	4 022	*29 679	4 022	*29 679	4 022				
		6 3/4	171.5	*36 742	4 979	35 824	4 854	32 277	4 374	29 966	4 060	26 675	3 614				
		7	177.8	38 379	5 200	35 824	4 854	32 277	4 374	29 966	4 060	26 675	3 614				
5 1/2	Dbl. Streamline Semi-IF	7 1/4	184.2	38 379	5 200	35 824	4 854	32 277	4 374	29 966	4 060	26 675	3 614				
		7 1/2	190.5	38 379	5 200	35 824	4 854	32 277	4 374	29 966	4 060	26 675	3 614				
		7 3/4	196.9	42 481	5 756	42 481	39 866	5 402	36 235	4 910	33 868	4 589	30 495	4 132			
		8	203.2	42 481	5 756	42 481	39 866	5 402	36 235	4 910	33 868	4 589	30 495	4 132			
5 1/2	H-90 ⁴	6 3/4	171.5	*34 508	4 676	*34 508	4 676	*34 508	4 676	*34 508	4 676	*34 508	4 676	30 781	4 171		
		7	177.8	*41 993	5 690	40 117	5 436	36 501	4 946	34 142	4 626	30 781	4 171				
		7 1/4	184.2	42 719	5 788	40 117	5 436	36 501	4 946	34 142	4 626	30 781	4 171				
		7 1/2	190.5	42 719	5 788	40 117	5 436	36 501	4 946	34 142	4 626	30 781	4 171				
5 1/2	API Regular	6 3/4	171.5	*31 941	4 328	*31 941	4 328	*31 941	4 328	*31 941	4 328	*31 941	4 328	30 495	4 132		
		7	177.8	*39 419	5 341	*39 419	5 341	*39 419	5 341	*39 419	5 341	*39 419	5 341	30 495	4 132		
		7 1/4	184.2	42 481	5 756	42 481	39 866	5 402	36 235	4 910	33 868	4 589	30 495	4 132			
		7 1/2	190.5	42 481	5 756	42 481	39 866	5 402	36 235	4 910	33 868	4 589	30 495	4 132			
5 1/2	API Full Hole	7	177.8	*32 762	4 439	*32 762	4 439	*32 762	4 439	*32 762	4 439	*32 762	4 439	*32 762	4 439		
		7 1/4	184.2	*40 998	5 555	*40 998	5 555	*40 998	5 555	*40 998	5 555	*40 998	5 555	*40 998	5 555		
		7 1/2	190.5	*49 661	6 729	*49 661	6 729	*49 661	6 729	*49 661	6 729	*49 661	6 729	*49 661	6 729		
		7 3/4	196.9	54 515	7 387	51 687	7 004	47 756	6 471	45 190	6 123	41 533	5 628				
API	NC56	7 1/4	184.2	*40 498	5 488	*40 498	5 488	*40 498	5 488	*40 498	5 488	*40 498	5 488	*40 498	5 488		
		7 1/2	190.5	*49 060	6 648	*49 060	6 648	*49 060	6 648	*49 060	6 648	*49 060	6 648	*49 060	6 648		
		7 3/4	196.9	52 115	7 062	52 115	7 062	48 221	6 534	45 680	6 190	42 058	5 699				
		8	203.2	52 115	7 062	52 115	7 062	48 221	6 534	45 680	6 190	42 058	5 699				

See notes at the end of B 46.

**RECOMMENDED MAKE-UP TORQUE¹
FOR ROTARY SHOULDERED DRILL COLLAR CONNECTIONS (continued)
(API RP 7G, 15th edition, January 1, 1995)**

Connection		Minimum make-up torque																	
		Bore of drill collars																	
		2 1/4		2 1/2		2 13/16		3		3 1/4		3 1/2		3 3/4					
Size (in)	Type	OD (in)	OD (mm)	(ft.lb)	(daN.m)	(ft.lb)	(daN.m)	(ft.lb)	(daN.m)	(ft.lb)	(daN.m)	(ft.lb)	(daN.m)	(ft.lb)	(daN.m)	(ft.lb)	(daN.m)		
6 5/8	API Regular	7 1/2	190.5	*46 399	6 287	*46 399	6 287	*46 399	6 287	*46 399	6 287	*46 399	6 287	*46 399	6 287				
		7 3/4	196.9	*55 627	7 538	7 228	53 346	7 228	50 704	6 870	46 936	6 360	46 936	6 360	46 936	6 360			
		8	203.2	57 393	7 777	7 777	53 346	7 228	50 704	6 870	46 936	6 360	46 936	6 360	46 936	6 360			
		8 1/4	209.6	57 393	7 777	7 777	53 346	7 228	50 704	6 870	46 936	6 360	46 936	6 360	46 936	6 360			
6 5/8	H-90 ⁴	7 1/2	190.5	*46 509	6 302	*46 509	6 302	*46 509	6 302	*46 509	6 302	*46 509	6 302	*46 509	6 302				
		7 3/4	196.9	*55 708	7 549	7 549	55 708	7 549	53 629	7 267	49 855	6 755	49 855	6 755	49 855	6 755			
		8	203.2	60 321	8 174	7 625	56 273	7 625	53 629	7 267	49 855	6 755	49 855	6 755	49 855	6 755			
		8 1/4	209.6	60 321	8 174	7 625	56 273	7 625	53 629	7 267	49 855	6 755	49 855	6 755	49 855	6 755			
API	NC61	8	203.2	*55 131	7 470	*55 131	7 470	*55 131	7 470	*55 131	7 470	*55 131	7 470	*55 131	7 470				
		8 1/4	209.6	*65 438	8 867	8 867	*65 438	8 867	61 624	8 867	8 350	61 624	8 867	8 350	61 624	8 350			
		8 1/2	215.9	72 670	9 847	9 268	68 398	9 268	65 607	8 890	8 350	61 624	8 890	8 350	61 624	8 350			
		8 3/4	222.3	72 670	9 847	9 268	68 398	9 268	65 607	8 890	8 350	61 624	8 890	8 350	61 624	8 350			
5 1/2	API IF	8	203.2	*56 641	7 675	*56 641	7 675	*56 641	7 675	*56 641	7 675	*56 641	7 675	*56 641	7 675				
		8 1/4	209.6	*67 133	9 097	9 097	*67 133	9 097	67 133	9 097	8 588	67 133	9 097	8 588	67 133	9 097			
		8 1/2	215.9	74 626	10 112	9 523	70 277	9 523	67 436	9 138	8 588	67 436	9 138	8 588	67 436	9 138			
		8 3/4	222.3	74 626	10 112	9 523	70 277	9 523	67 436	9 138	8 588	67 436	9 138	8 588	67 436	9 138			
6 5/8	API Full Hole	9	228.6	74 626	10 112	70 277	9 523	70 277	9 523	67 436	9 138	67 436	9 138	67 436	9 138				
		9 1/4	235.0	74 626	10 112	70 277	9 523	70 277	9 523	67 436	9 138	67 436	9 138	67 436	9 138				
		8 1/2	215.9	*67 789	9 186	9 186	*67 789	9 186	*67 789	9 186	*67 789	9 186	*67 789	9 186	*67 789	9 186	67 184	9 104	
		8 3/4	222.3	*79 544	10 778	10 778	*79 544	10 778	79 544	10 778	76 706	10 394	76 706	10 394	76 706	10 394	76 706	10 394	9 104
API	NC70	9	228.6	88 582	12 003	83 992	11 381	83 992	11 381	80 991	10 974	80 991	10 974	76 706	10 394	72 102	9 770	67 184	9 104
		9 1/4	235.0	88 582	12 003	83 992	11 381	83 992	11 381	80 991	10 974	80 991	10 974	76 706	10 394	72 102	9 770	67 184	9 104
		9 1/2	241.3	88 582	12 003	83 992	11 381	83 992	11 381	80 991	10 974	80 991	10 974	76 706	10 394	72 102	9 770	67 184	9 104
		10	254.0	113 710	15 408	108 841	14 748	108 841	14 748	105 657	14 317	101 107	105 657	14 317	101 107	13 700	96 214	90 984	12 328
API	NC70	10 1/4	260.4	113 710	15 408	108 841	14 748	108 841	14 748	105 657	14 317	101 107	105 657	14 317	13 700	96 214	90 984	12 328	
		9	228.6	*75 781	10 268	10 268	*75 781	10 268	*75 781	10 268	*75 781	10 268	*75 781	10 268	*75 781	10 268	*75 781	10 268	12 033
		9 1/4	235.0	*88 802	12 033	12 033	*88 802	12 033	*88 802	12 033	*88 802	12 033	*88 802	12 033	*88 802	12 033	*88 802	12 033	12 033
		9 1/2	241.3	*102 354	13 869	13 869	*102 354	13 869	*102 354	13 869	*102 354	13 869	*102 354	13 869	*102 354	13 869	*102 354	13 869	13 037
API	NC70	9 3/4	247.7	113 710	15 408	108 841	14 748	108 841	14 748	105 657	14 317	101 107	105 657	14 317	13 700	96 214	90 984	12 328	
		10	254.0	113 710	15 408	108 841	14 748	108 841	14 748	105 657	14 317	101 107	105 657	14 317	13 700	96 214	90 984	12 328	
		10 1/4	260.4	113 710	15 408	108 841	14 748	108 841	14 748	105 657	14 317	101 107	105 657	14 317	13 700	96 214	90 984	12 328	
		10 1/4	260.4	113 710	15 408	108 841	14 748	108 841	14 748	105 657	14 317	101 107	105 657	14 317	13 700	96 214	90 984	12 328	

See notes at the end of B 46.

**RECOMMENDED MAKE-UP TORQUE¹
FOR ROTARY SHOULDERED DRILL COLLAR CONNECTIONS (continued)
(API RP 7G, 15th edition, January 1, 1995)**

Connection		Minimum make-up torque																
		Bore of drill collars																
		Size (in)	Type	OD (in)	2 1/4 (ft.lb)	2 1/4 (daN.m)	2 1/2 (ft.lb)	2 1/2 (daN.m)	2 13/16 (ft.lb)	2 13/16 (daN.m)	3 (ft.lb)	3 (daN.m)	3 1/4 (ft.lb)	3 1/4 (daN.m)	3 1/2 (ft.lb)	3 1/2 (daN.m)	3 3/4 (ft.lb)	3 3/4 (daN.m)
API	NC77	10 1/4 260.4 10 1/2 266.7 10 3/4 273.1 11 279.4			*108 194 *124 051 *140 491 154 297 154 297	14 660 16 809 19 037 20 907 20 907	14 660 16 809 19 037 20 907 20 907	*108 194 *124 051 *140 491 148 965 148 965	14 660 16 809 19 037 20 907 20 185	14 660 16 809 19 037 20 907 20 185	*108 194 *124 051 *140 491 148 965 148 965	14 660 16 809 19 037 20 907 20 185	*108 194 *124 051 *140 491 148 965 148 965	14 660 16 809 19 037 20 907 20 185	*108 194 *124 051 *140 491 148 965 148 965	14 660 16 809 19 037 20 907 20 185	*108 194 *124 051 *140 491 148 965 148 965	14 660 16 809 19 037 20 907 20 185
7	H-90 ⁴	8 203.2 8 1/4 209.6 8 1/2 215.9			*53 454 *63 738 *74 478	7 243 8 637 10 092	7 243 8 637 9 765	*53 454 *63 738 72 066	7 243 8 637 9 765	*53 454 *63 738 69 265	7 243 8 637 8 844	*53 454 *63 738 65 267	7 243 8 262 8 262	*53 454 60 971 60 971	7 243 8 262 8 262	*53 454 56 382 56 382	7 243 7 640 7 640	
7 5/8	API Regular	8 1/2 215.9 8 3/4 222.3 9 228.6 9 1/4 235.0 9 1/2 241.3			*60 402 *72 169 *84 442 96 301 96 301	8 185 9 779 11 442 13 049 13 049	8 185 9 779 11 442 12 416 12 416	*60 402 *72 169 *84 442 91 633 91 633	8 185 9 779 11 442 12 416 12 416	*60 402 *72 169 *84 442 88 580 88 580	8 185 9 779 11 442 11 412 11 412	*60 402 *72 169 *84 442 84 221 84 221	8 185 9 779 10 777 10 777 10 777	*60 402 *72 169 *84 442 79 536 79 536	8 185 9 779 10 777 10 777 10 777	*60 402 *72 169 *84 442 74 529 74 529	8 185 9 779 10 099 10 099 10 099	
7 5/8	H-90 ⁴	9 228.6 9 1/4 235.0 9 1/2 241.3			*73 017 *86 006 *99 508	9 894 11 654 13 483	9 894 11 654 13 483	*73 017 *86 006 *99 508	9 894 11 654 13 483	*73 017 *86 006 *99 508	9 894 11 654 13 483	*73 017 *86 006 *99 508	9 894 11 654 13 483	*73 017 *86 006 *99 508	9 894 11 654 13 483	*73 017 *86 006 *99 508	9 894 11 654 13 047	
8 5/8	API Regular	10 254.0 10 1/4 260.4 10 1/2 266.7			*109 345 *125 263 *141 767	14 816 16 973 19 210	14 816 16 973 19 210	*109 345 *125 263 *141 767	14 816 16 973 19 210	*109 345 *125 263 141 134	14 816 16 973 18 448	*109 345 *125 263 136 146	14 816 16 973 17 653	*109 345 *125 263 130 277	14 816 16 973 17 653	*109 345 *125 034 125 034	14 816 16 942 16 942	
8 5/8	H-90 ⁴	10 1/4 260.4 10 1/2 266.7			*113 482 *130 063	15 377 17 624	15 377 17 624	*113 482 *130 063	15 377 17 624	*113 482 *130 063	15 377 17 624	*113 482 *130 063	15 377 17 624	*113 482 *130 063	15 377 17 624	*113 482 *130 063	15 377 17 624	
7	H-90 ⁴ (with low torque face)	8 222.3 9 228.6			*68 061 74 235	9 222 10 059	9 222 10 059	*68 061 74 235	9 222 10 059	*68 061 71 361	9 222 9 670	*68 061 67 257	9 222 9 670	*68 061 62 845	9 222 9 670	*68 061 62 845	9 222 9 670	
7 5/8	API Regular (with low torque face)	9 1/4 235.0 9 1/2 241.3			*73 099 *86 463	9 905 11 716	9 905 11 716	*73 099 *86 463	9 905 11 716	*73 099 *86 463	9 905 11 716	*73 099 *86 463	9 905 11 716	*73 099 82 457	9 905 11 173	*73 099 77 289	9 905 10 473	
9 3/4 10		247.7 254.0			91 789 91 789	12 438 12 438	12 438 12 438	91 789 91 789	12 438 12 438	91 789 87 292	12 438 11 828	91 789 87 292	12 438 11 828	91 789 82 457	12 438 11 173	91 789 77 289	12 438 10 473	

See notes at the end of B 46.

RECOMMENDED MAKE-UP TORQUE¹ FOR ROTARY SHOULDERED DRILL COLLAR CONNECTIONS (continued) (API RP 7G, 15th edition, January 1, 1995)

Connection		Minimum make-up torque														
		Bore of drill collars														
		2 1/4		2 1/2		2 13/16		3		3 1/4		3 1/2		3 3/4		
Size	Type	OD	(ft.lb)	(daN.m)	(ft.lb)	(daN.m)	(ft.lb)	(daN.m)	(ft.lb)	(daN.m)	(ft.lb)	(daN.m)	(ft.lb)	(daN.m)	(ft.lb)	(daN.m)
7 5/8	H-90 ⁴ (with low torque face)	9 3/4														
		10			*91 667 *106 260	12 421 14 398	*91 667 *106 260	12 421 14 398	*91 667 *106 260	12 421 14 398	*91 667 104 171	12 421 14 115	*91 667 104 171	12 421 14 115	*91 667 98 804	12 421 13 388
8 5/8	API Regular (with low torque face)	10 1/4														
		10 1/2			117 112 117 112	15 869 15 869	113 851 113 851	15 427 15 427	109 188 109 188	14 795 14 795	104 171 104 171	14 115 14 115	104 171 104 171	14 115 14 115	98 804 98 804	13 388 13 388
8 5/8	H-90 ⁴ (with low torque face)	10 3/4														
		11					*112 883 *130 672	15 296 17 706	*112 883 *130 672	15 296 17 706	*112 883 *130 672	15 296 17 706	*112 883 *130 672	15 296 17 706	*112 883 *130 672	15 296 17 706
8 5/8	H-90 ⁴ (with low torque face)	11 1/4														
		10 3/4					147 616 *92 960 *110 781	20 002 12 596 15 011	14 243 *92 960 *110 781	1 930 12 596 15 011	136 846 *92 960 *110 781	18 543 12 596 15 011	130 871 *92 960 *110 781	17 733 12 596 15 011	17 733 12 596 15 011	
8 5/8		11 1/4														

Notes

- (1) Torque figures preceded by an asterisk indicate that the weaker member for the corresponding outside diameter (OD) and bore is the BOX. For all other torque values the weaker member is the PIN.
- (2) In each connection size and type group, torque values apply to all connection types in the group, when used with the same drill collar outside diameter, i.e. 2 3/8 API IF, API NC26, and 2 7/8 Slim Hole connections used with 3 1/2 x 1 1/4 drill collars all have the same minimum make-up torque of 4600 ft.lb, and the BOX is the weaker member.
- (3) Stress relief features are disregarded for make-up torque.
1. Basis of calculations for recommended make-up torque assume the use of a thread compound containing 40-60% by weight of finely powdered metallic zinc or 60% by weight of finely powdered metallic lead, with not more than 0.3% total active sulfur (reference the caution regarding the use of hazardous materials in Appendix F of Specification 7) applied thoroughly to all threads and shoulders and using the modified Screw Jack formula in Appendix A, paragraph A.8, and a unit stress of 62 500 psi in the box or pin, whichever is weaker.
2. Normal torque range is tabulated value plus 10%. Higher torque values may be used under extreme conditions.
3. Make-up torque for 2 7/8 PAC connection is based on 87 500 psi stress and other factors listed in footnote 1.
4. Make-up torque for H-90 connection is based on 56 200 psi stress and other factors listed in footnote 1.

HEAVY WALL DRILL PIPES (Drilco, Division of Smith International, Inc)

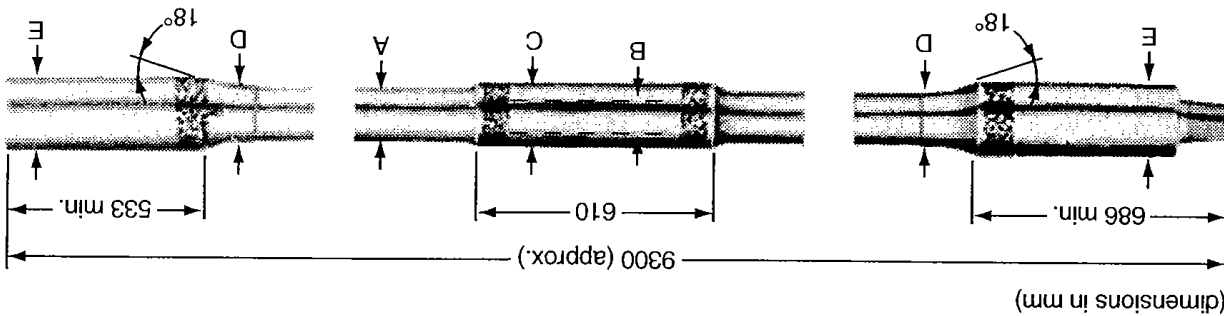

Characteristics, Range II

Nominal size (A) (in)	Drill pipe body					Tool joint				
	Body nominal dimensions		Central upset outside diameter (C) (in) (mm)	End upset outside diameter (D) (in) (mm)	Pipe mechanical properties		Connection	Outside diameter (E) (in) (mm)	Inside diameter (in) (mm)	
	Inside diameter (B) (in) (mm)	Wall thickness (mm)			Cross-sectional area (mm ²)	Tensile yield (10 ³ daN)				Torsional yield (daN.m)
3 1/2	2 1/16 52.4	18.2	4051	4 101.6	3 5/8 92.1	153	2654	NC38 (3 1/2 IF)	4 3/4 120.7	2 3/16 55.6
4	2 9/16 65.1	18.2	4779	4 1/2 114.3	4 1/8 104.8	181	3747	NC40 (4 FH)	5 1/4 133.4	2 11/16 68.3
4 1/2	2 3/4 69.9	22.2	6427	5 127.0	4 5/8 117.5	244	5520	NC46 (4 IF)	6 1/4 158.8	2 7/8 73.0
5	3 76.2	25.4	8106	5 1/2 139.7	5 1/8 130.2	307	7660	NC50 (4 1/2 IF)	6 1/2 165.12	3 1/8 79.4

Characteristics, Range II (continued)

Nominal size (A) (in)	Tool joint			Weight		Make-up torque (daN.m)	Volumes		
	Connection	Mechanical properties		Pipe + tool joint			Exterior (l/m)	Interior (l/m)	
		Tensile yield (10 ³ daN)	Torsional yield (daN.m)	Linear weight (kg/m)	Pipe weight (30 ft) (kg)				
3 1/2	NC38 (3 1/2 IF)	333	2383	37.7	344.3	1342	7.00	2.19	4.81
4	NC40 (4 FH)	316	3190	44.2	404.2	1797	9.01	3.37	5.64
4 1/2	NC46 (4 IF)	456	5260	61.0	557.9	2956	11.66	3.87	7.79
5	NC50 (4 1/2 IF)	563	6966	73.4	670.9	3985	13.97	4.61	9.36

mm x 0.0394 = in mm² x 0.00155 = in² daN.m x 7.38 = lb.ft daN x 2.25 = lb
 kg/m x 0.672 = lb/ft kg x 2.20 = lb l/m x 0.0805 = gal/ft l/m x 0.00192 = bbl/ft

HEAVY WALL DRILL PIPES (Drilco, Division of Smith International, Inc) (continued)

B 48

Characteristics, Range III										
Nominal size (A)	Drill pipe body					Tool joint				
	Body nominal dimensions			Central upset outside diameter (C) (in) (mm)	End upset outside diameter (D) (in) (mm)	Pipe mechanical properties		Connec- tion	Outside diameter (E) (in) (mm)	Inside diameter (in) (mm)
	Inside diameter (B) (in) (mm)	Wall thickness (mm)	Cross-sectional area (mm ²)			Tensile yield (10 ³ daN) 244	Torsional yield (daN.m) 5520			
4 1/2 (in)	2 3/4 69.9	22.2	6427	5 127.0	4 5/8 117.5	244	5520	NC46 (4 IF)	6 1/4 158.8	2 7/8 73.0
5	3 76.2	25.4	8106	5 1/2 139.7	5 1/8 130.2	307	7660	NC50 (4 1/2 IF)	6 1/2 165.1	3 1/8 79.4

Characteristics, Range III (continued)										
Nominal size (A)	Tool joint				Weight		Make-up torque		Volumes	
	Connection	Mechanical properties		Pipe + tool joint	Linear weight (kg/m)	Pipe weight (44 ft) (kg)	Make-up torque (daN.m) 2956	Exterior (l/m)	Interior (l/m)	Steel volume (l/m) 7.57
		Tensile yield (10 ³ daN) 456	Torsional yield (daN.m) 5260							
4 1/2 (in)	NC46 (4 IF)	456	5260	796.3	59.4	796.3	2956	11.66	3.87	7.57
5	NC50 (4 1/2 IF)	563	6966	968.0	72.2	968.0	3985	13.81	4.61	9.20

mm x 0.0394 = in mm² x 0.00155 = in² daN.m x 7.38 = lb.ft daN x 2.25 = lb
kg/m x 0.672 = lb/ft l/m x 0.220 = lb l/m x 0.0805 = gal/ft l/m x 0.00192 = bb/ft

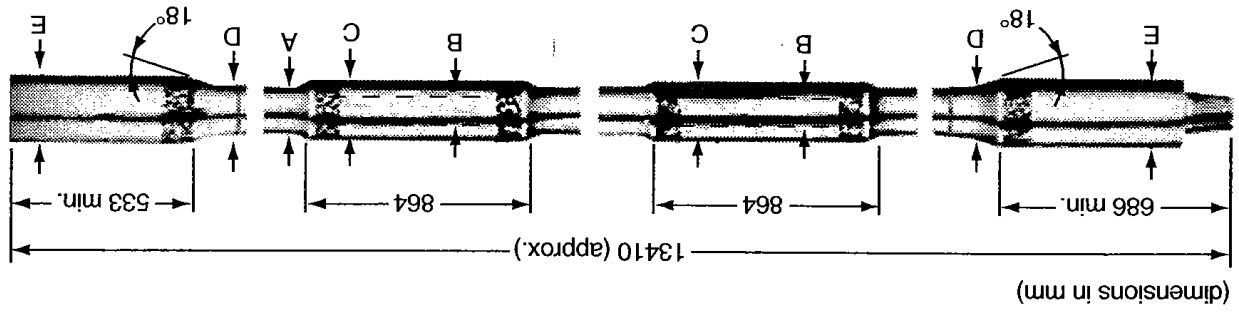

KELLYS

(API Spec 7, 38th edition, April 1, 1994)

Kelly size G (in)	Inside diameter E (in)	Length (m)		Upper box connection left hand female thread			Lower pin connection right hand male thread			Drive connection		Total weight (kg)			
		Overall A	Drive section B	Size and style		Outside diameter C		Size and style		Outside diameter D		Across flats	Across corners	Std	opt
				Std	Opt	Std	Opt	Std	Opt	Std	Opt				
Square kellys															
2 1/2	1 1/4	12.19	-	6 5/8 REG	4 1/2 REG	7 3/4	5 3/4	NC26	2 3/8 IF	3 3/8	2 1/2	3 9/32	404	358	
3	1 3/4	12.19	-	6 5/8 REG	4 1/2 REG	7 3/4	5 3/4	NC31	2 7/8 IF	4 1/8	3	3 15/16	490	445	
3 1/2	2 1/4	12.19	-	6 5/8 REG	4 1/2 REG	7 3/4	5 3/4	NC38	3 1/2 IF	4 3/4	3 1/2	4 17/32	600	552	
4 1/4	2 13/16	12.19	16.46	6 5/8 REG	4 1/2 REG	7 3/4	5 3/4	{NC46	4 IF	6 1/4	4 1/4	5 9/16	840	788	
5 1/4	3 1/4	12.19	16.46	6 5/8 REG	-	7 3/4	-	NC50	4 1/2 IF	6 3/8	5 1/4	6 29/32	1260	-	
5 1/4	3 1/4	12.19	16.46	6 5/8 REG	-	7 3/4	-	NC56	5 1/2 FH	7	5 1/4	6 29/32	1260	-	
Hexagonal kellys															
3 1/2	1 1/2	12.19	-	6 5/8 REG	4 1/2 REG	7 3/4	5 3/4	NC26	2 3/8 IF	3 3/8	3	3 3/8	440	395	
4 1/4	1 3/4	12.19	-	6 5/8 REG	4 1/2 REG	7 3/4	5 3/4	NC31	2 7/8 IF	4 1/8	3 1/2	3 15/16	567	532	
5 1/4	2 1/4	12.19	16.46	6 5/8 REG	4 1/2 REG	7 3/4	5 3/4	NC38	3 1/2 IF	4 3/4	4 1/4	4 25/32	886	840	
5 1/4	3 1/4	12.19	16.46	6 5/8 REG	-	7 3/4	-	NC46	4 IF	6	5 1/4	5 29/32	990	-	
5 1/4	2 13/16	12.19	16.46	6 5/8 REG	-	7 3/4	-	NC50	4 1/2 IF	6 1/8	5 1/4	5 29/32	965	-	
5 1/4	2 13/16	12.19	16.46	6 5/8 REG	-	7 3/4	-	NC46	4 IF	6 1/4	5 1/4	5 29/32	1007	-	
6	3 1/2	12.19	16.46	6 5/8 REG	-	7 3/4	-	NC50	4 1/2 IF	6 3/8	5 1/4	5 29/32	1007	-	
6	3 1/2	12.19	16.46	6 5/8 REG	-	7 3/4	-	NC56	5 1/2 IF	7	6	6 13/16	1095	-	

m x 3.28 = ft kg x 2.20 = lb

STRENGTH OF KELLYS (1)
(API RP 7G, 15th edition, January 1, 1995)

Kelly size and style (in)	Inside diameter (in)	Lower pin connection		Minimum recommended casing OD (2) (in)	Tensile yield		Torsional yield		Yield in bending (m.daN)	Internal pressure at yield stress (MPa)
		Size and style	Outside diameter (in)		Lower pin connection (3) (10 ³ daN)	Drive section (10 ³ daN)	Lower pin connection (daN.m)	Drive section (daN.m)		
Square	2 1/4	NC26 (2 3/8 IF)	3 3/8	4 1/2	185	198	1 310	1 680	1 680	205.5
	3	NC31 (2 7/8 IF)	4 1/8	5 1/2	238	259	1 960	2 670	2 710	175.8
	3 1/2	NC38 (3 1/2 IF)	4 3/4	6 5/8	322	323	3 080	3 930	4 010	153.1
	4 1/4	NC46 (4 IF)	6 1/4	8 5/8	468	466	5 335	6 810	7 000	134.5
	4 1/4	NC50 (4 1/2 IF)	6 3/8	8 5/8	632	466	7 760	6 810	7 000	134.5
5 1/4	3 1/4	5 1/2 FH	7	9 5/8	715	758	9 900	13 700	13 940	142.0...
Hexagonal	1 1/2	NC26 (2 3/8 IF)	3 3/8	4 1/2	158	240	1 125	2 780	2 520	184.1
	1 7/8	NC31 (2 7/8 IF)	4 1/8	5 1/2	220	316	1 815	4 270	3 880	175.8
	2 1/4	NC38 (3 1/2 IF)	4 3/4	6 5/8	322	466	3 080	7 700	6 980	172.4
	3	NC46 (4 IF)	6 1/4	8 5/8	426	671	4 805	13 870	12 610	142.0
	3 1/4	NC50 (4 1/2 IF)	6 3/8	8 5/8	512	621	6 335	13 030	11 880	142.0
	6	3 1/2	5 1/2 FH	7	9 5/8	650	861	8 990	20 400	18 580

(1) None of the values is corrected by a safety factor. They are based on a minimum tensile yield strength of 758 MPa (110 000 psi) for connections, and 620 MPa (90 000 psi) for the drive section, and on a shear strength of 57.7% of the minimum tensile yield strength.

(2) Clearance between protector rubber on Kelly saver sub and casing inside diameter should also be checked.

(3) Tensile area calculated at thread root 3/4 inch from pin shoulder.

daN x 2.25 = lb daN.m x 7.38 = lb.ft MPa x 145 = psi

STRETCH OF SUSPENDED DRILL PIPE

STRETCH DUE TO ITS OWN WEIGHT

$$A_a = 0.0785 \frac{L^2}{2E}$$

L = length of string (m)

E = modulus of elasticity = 210 000 MPa

$$A_a \text{ in meters} = 1.87 \cdot 10^{-7} L^2$$

SHRINKAGE DUE TO BUOYANCY IN MUD

$$A_b = -\frac{d_b L^2}{E} (1 - \nu)$$

d_b = mud specific gravity

L = length of string (m)

E = modulus of elasticity = 210 000 MPa

ν = Poisson's ratio = 0.3 for steel

$$A_b \text{ in meters} = -0.334 \cdot 10^{-7} d_b L^2$$

STRETCH DUE TO TEMPERATURE

$$A_t = 11.88 \cdot 10^{-6} L dt$$

L = length of string (m)

dt = temperature variation of the mud

TOTAL STRETCH

$$A = A_a + A_b + A_t$$

$$A = L^2 \cdot 10^{-7} (1.87 - 0.334 d_b) + 11.8 \cdot 10^{-6} L dt$$

DRILL STEM DESIGN CALCULATIONS (API RP 7G, 15th edition, January 1, 1995)

A. DESIGN PARAMETERS

- a) Anticipated total depth with this string.
- b) Hole size.
- c) Mud weight.
- d) Desired Factor of Safety in tension and/or Margin of Over Pull.
- e) Desired Factor of Safety in collapse.
- f) Length of drill collars, OD, ID, and weight per meter.
- g) Drill pipe sizes and inspection class.

B. TENSION LOADING

$$T = 0.981 \times 10^{-3} (L_{DP}P_{DP} + L_{DC}P_{DC})k$$

where:

- T = submerged load hanging below the upper end of this section of drill pipe (10^3 daN)
 L_{DP} = length of drill pipe of section considered (m)
 L_{DC} = length of drill collars (m)
 P_{DP} = weight per meter of drill pipe assembly in air (kg/m)
 P_{DC} = weight per meter of drill collar in air (kg/m)
 k = buoyancy factor.

C. ALLOWABLE LOAD. FACTOR OF SAFETY. MARGIN OF OVER PULL

$$T_a = 0.9 T_e$$

where:

- T_a = maximum allowable load on this pipe in tension (10^3 daN)
 T_e = yield strength of this pipe (10^3 daN)

$$R_T = T_a - T$$

- R_T = Margin of Over Pull (MOP) (10^3 daN) on this drill pipe

$$F_S = \frac{T_a}{T}$$

- F_S = safety factor in tension on this drill pipe.

DRILL STEM DESIGN CALCULATIONS (continued) (API RP 7G, 15th edition, January 1, 1995)

D. MAXIMUM DRILLING DEPTH

Considering the type of drill pipe, the load and the desired safety, the string length is limited to the following:

$$L_{DP \max} = \frac{0.9 T_e 10^3}{F_S P_{DP} k} - \frac{P_{DC} L_{DC}}{P_{DP}}$$

or:

$$L_{DP \max} = \frac{10^3(0.9 T_e - R_T)}{k P_{DP}} - \frac{P_{DC} L_{DC}}{P_{DP}}$$

$L_{DP \max}$ = maximum length (in m) of this drill string taking account of the desired safety, the pipe mechanical properties, the load of the drill collars and the mud.

Composite drill strings

If the drill string is composite, i.e. consisting of sections of pipes which differ in their nominal size, grade or wear class, the weakest section in tension must be placed above the drill collars and its maximum length is calculated as above. A stronger section is placed above and its maximum length can be calculated by using the equation for D, but by replacing the term $P_{DC} L_{DC}$ by the weight in air of the drill collars plus the weight of the weakest section.

E. COLLAPSE DUE TO ANNULAR HYDROSTATIC PRESSURE

$$P_{ca} = \frac{P_{ct}}{F_c}$$

where:

P_{ct} = limit collapse pressure (kPa)

P_{ca} = maximum allowable collapse pressure (kPa)

F_c = collapse safety factor

When the fluid levels inside and outside the drill pipe are equal, the collapse pressure (equal to the differential hydrostatic pressure) is zero.

DRILL STEM DESIGN CALCULATIONS (continued) **(API RP 7G, 15th edition, January 1, 1995)**

If there is no fluid inside the pipe (for example, during testing), the collapse pressure is:

$$P_C = 9.81 Z d$$

where:

P_C = collapse pressure (kPa)

Z = vertical depth (m)

d = mud weight (kg/l)

F. TORSIONAL STRENGTH

The torque applied to the drill string should not exceed the actual tool joint make-up torque. For a composite string, the torsional torque at the rotary table should be limited to the lowest value of the tool joint make-up torque.

Torsional deformation

The following formula can be used to calculate the number of rotations causing torsional deformation of a drill string, ignoring friction and tool joints:

$$N = 1.49 \frac{ML}{\left(\frac{I_0}{R}\right) D}$$

where:

N = number of torsional rotations

M = applied torque (daN.m)

L = length of drill pipes (m)

$\frac{I_0}{R}$ = polar modulus (mm³)

D = pipe outside diameter (in)

Torsion limit taking account of tensile load

In certain drilling configurations, such as washover, deep holes, highly-deviated holes, use of a power swivel etc., it may be necessary to apply a high torque to the drill string. The pipes must withstand both the tensile and torsional loads.

The API criterion is as follows:

$$n^2 + 3t^2 \leq Y_p^2$$

where:

Y_p = yield strength

n = normal stress

t = tangential stress

DRILL STEM DESIGN CALCULATIONS (continued) (API RP 7G, 15th edition, January 1, 1995)

The following formula can be used to calculate the maximum allowable torque:

$$\left(\frac{T}{T_e}\right)^2 + \left(\frac{M}{M_e}\right)^2 \leq 1$$

where:

T = tensile load on pipe

T_e = tensile yield strength

M = torsional torque on pipe

M_e = torque at maximum allowable stress

- Calculation of the maximum allowable torque for a tensile load T and the pipe mechanical properties:

$$M < M_e \sqrt{1 - \left(\frac{T}{T_e}\right)^2}$$

- Calculation of the maximum allowable tensile load for a torque M and the pipe mechanical properties:

$$T < T_e \sqrt{1 - \left(\frac{M}{M_e}\right)^2}$$

DRILL STEM DESIGN CALCULATIONS CALCULATION EXAMPLES

Design parameters

Depth = 3800 m

Hole size = 8 1/2

Mud weight = 1.16

Desired MOP = 30 10³ daN

Safety factor in collapse = 1.15

Size of drill collars = 6 3/4 × 2 13/16

Length of drill collars = 185 m

The following formula can be used to calculate the length of drill collars (if necessary):

$$L_{DC} = \frac{10^5 WOB}{\cos \alpha F_{PN} P_{DC} k}$$

where:

L_{DC} = length of drill collars (m)

WOB = maximum weight on bit (t)

α = hole angle from vertical

F_{PN} = neutral point position as percentage of the total drill collar string length

P_{DC} = weight per meter of drill collars (kg/m)

k = buoyancy factor

I Numerical application

α = 3 degrees

WOB = 20 t

F_{PN} = 85%

k = 0.852

P_{DC} = 149.8 kg/m

$$L_{DC} = \frac{20 \cdot 10^5}{(0.998)(85)(149.8)0.852} = 185 \text{ m or } 20DC$$

DRILL STEM DESIGN CALCULATIONS CALCULATION EXAMPLES (continued)

II Pipe size, weight and grade used

5 in – 19.50 lb/ft, Grade E, NC50 tool joints, Inspection Class II

$$P_{DP1} = 31.06 \text{ kg/m}$$

$$T_{e1} = 120.3 \cdot 10^3 \text{ daN}$$

$$P_{ct} = 30\,000 \text{ kPa}$$

- Calculation of the maximum pipe length taking account of the desired MOP:

$$L_{DP1} = \frac{10^3(0.9 \times 120.3 - 30)1.02}{0.852 \times 31.06} - \frac{(185 \times 149.8)}{31.06}$$

$$L_{DP1} = 2125 \text{ m}$$

It is apparent that drill pipe of a higher strength will be required to reach 3800 m. For example, the following pipes can be used:

5 in – 19.50 lb/ft, Grade X, NC50 tool joint, Premium Class

$$P_{DP2} = 31.83 \text{ kg/m}$$

$$T_{e2} = 175.6 \cdot 10^3 \text{ daN}$$

- Calculation of the maximum pipe length considering the MOP and weight of the first section:

$$L_{DP2} = \frac{10^3(0.9 \times 175.6 - 30)1.02}{0.852 \times 31.83} - \frac{(2125 \times 31.06) + (185 \times 149.8)}{31.83}$$

$$L_{DP2} = 1872 \text{ m}$$

The depth of 3800 m can therefore be reached with these drill strings and in the requisite conditions.

**DRILL STEM DESIGN CALCULATIONS
CALCULATION EXAMPLES (continued)**

Summary of string weights and dimensions:

	Length (m)	Weight on air (t)	Weight in mud (t)
Drill collars $P_{DC} = 149.8 \text{ kg/m}$	185	27.7	23.6
No. 1 pipe 5 in – 19.50, Grade E Class II $P_{DP1} = 31.06 \text{ kg/m}$	2125	66.0	56.2
No. 2 pipe 5 in – 19.50, Grade X Premium Class $P_{DP1} = 31.06 \text{ kg/m}$	1490	47.4	40.4
Total	3800	141.1	120.2

III Collapse pressure

For the No. 1 pipes, the limit collapse pressure is:

$$P_{ct1} = 38 \text{ MPa}$$

The maximum hydrostatic pressure on the No. 1 pipes is:

$$P_h = 9.81 \times 1.16 \times (3800 - 185)$$

$$P_h = 41\,140 \text{ kPa or } 41.14 \text{ MPa}$$

The string cannot be run empty to the final depth.

- Calculation of the maximum depth that can be reached by empty No. 1 pipes with a safety factor of 1.15:

$$L_{\max} = \frac{38\,000}{9.81 \times 1.16 \times 1.15} = 2\,904 \text{ m}$$

DRILL STEM DESIGN CALCULATIONS CALCULATION EXAMPLES (continued)

IV Combination of tensile and torsional loads

Let us consider the use of a power swivel to pull out the string in rotation to release it. In this case, the combination of the tensile load and torque may be high.

The string is at the maximum depth.

- Maximum allowable tensile load at surface: $120.3 + 30 = 150.3 \cdot 10^3$ daN.
Torque at maximum allowable stress of No. 1 pipes: $M_e = 3790$ daN.m.
Make-up torque of tool joints: 1900 daN.m.
Load on No. 1 pipes: $(56.2 + 23.6) \cdot 0.981 + 30 = 108.3 \cdot 10^3$ daN.
Tensile yield strength: $T_{e1} = 120.3 \cdot 10^3$ daN.

$$M < M_e \sqrt{1 - \left(\frac{T}{T_{e1}}\right)^2}$$

$$M < 3790 \sqrt{1 - \left(\frac{108.3}{120.3}\right)^2} = 1650 \text{ daN.m}$$

The torque limit should be **1650** daN.m.

- Calculation of maximum torque with extra tensile load of $15 \cdot 10^3$ daN.
Load on No. 1 pipes: $(56.2 + 23.6) \cdot 0.981 + 15 = 93.3 \cdot 10^3$ daN.

$$M < 3790 \sqrt{1 - \left(\frac{93.3}{120.3}\right)^2} = 2393 \text{ daN.m}$$

The torque limit remains the minimum make-up torque, i.e. **1900** daN.m.

**CRITICAL BUCKLING FORCE
(Baker Hughes INTEQ)**

Formula Critical Buckling force in drill pipe (Dawson and Paslay):

$$F_{cr} = 2 (EIW \sin\theta/r)^{1/2} \quad (\text{lbs})$$

E = Young's modulus (psi)

I = Axial moment of inertia (in⁴)

W = Buoyed weight per unit length (lb/in)

θ = Bore-hole inclination

r = Radial clearance between the pipe and the bore-hole wall (in)

If the compressive force reaches F_{cr} , then **sinusoidal buckling** occurs

Metric formula:

$$F_{cr} = 2/99.03 (EIW \sin\theta/r)^{1/2} \quad (\text{kgf})$$

E (MPa) ; I (mm⁴) ; W (kg/m) ; r (mm)

Application:

$E = 29 \times 10^6$ psi (199 950 MPa)

4 1/2 DP – E – 16.66 lb/ft: approximate weight = 17.99 lb/ft (26.77 kg/m) B 10

8 1/2 Hole – Inclination = 50° – Mud weight = 14 ppg, buoyancy factor = **0.786**. A 37

$I = \pi/64 (4.5^4 - 3.826^4) = 9.61$ in⁴ (8 000 523/2 = 4 000 263 mm⁴) B 10

$W = (17.99/12) * 0.786 = 1,178$ lb/in (26.77 * 0.786 = 21.04 kg/m)

$\sin 50 = 0.766$ $r = 8.5 - 4.5 = 2$ in (50.8 mm)

$F_{cr} = 2 (29 \times 10^6 \times 9.61 \times 1.178 \times 0.766/2)^{1/2} = 22\ 420$ lbs

Metric formula:

$F_{cr} = 2/99.03(199\ 950 \times 4\ 000\ 263 \times 21.04 \times 0.766/50.8)^{1/2} = 10\ 170$ kgf

C

casing, tubing line pipe standards

Tensile requirements. Casing and tubing (API Standard 5CT, 5 th edition, April 1, 1995). Line pipe (API Standard 5L, April 1, 1995).....	C1
Tensile requirements of special steels (non-API) (Vallourec & Mannesmann documentation).....	C2
API casing list (API Specification 5CT, 5 th edition, April 1, 1995).....	C3-C4
API tubing list (API Specification 5CT, 5 th edition, April 1, 1995).....	C5
Drift diameter (API Standard 5CT, 5 th edition, April 1, 1995).....	C6
Efficiency of a connection.....	C7
Make-up torque.....	C8
Geometrical characteristics and mechanical properties of small-diameter tubing.....	C9-C15
Geometrical characteristics and mechanical properties of tubing.....	C16-C34
Geometrical characteristics and mechanical properties of casing.....	C35-C79
Geometrical characteristics and mechanical properties of coiled tubing.....	C80-C87
Geometrical characteristics and mechanical properties of line pipe, risers and conductor pipe.....	C88-C90

API and buttress casing thread forms. API round threads form. Buttress thread form.....	C91
API tubing thread form.....	C92
Effect of tensile load on collapse resistance	C93
Ellipse of biaxial yield stress. Effect of tensile load on collapse resistance.....	C94
Qualitative influence of various operations on the stresses in a partially-cemented casing string.....	C95
Quantitative influence of temperature and pressure variations on the stresses in a partially-cemented casing string.....	C96-C97

TENSILE REQUIREMENTS

Casing and tubing

(API Standard 5CT, 5th edition, April 1, 1995)

Properties	Grade	H40	J55	K55	N80	L80 (1)	C90 (2)	C95	T95 (3)	P110	Q125 (4)
Grade color band codes (5)		1 black	1 green	2 green	1 red	1 red and 1 brown	1 purple	1 brown	1 silver	1 white	1 orange
Minimum yield strength (MPa)		276	379	379	551	551	620	655	655	758	862
Maximum yield strength (psi)		40 000	55 000	55 000	80 000	80 000	90 000	95 000	95 000	110 000	125 000
Minimum yield strength (MPa)		551	551	551	758	655	724	758	758	965	1034
Maximum yield strength (psi)		80 000	80 000	80 000	110 000	95 000	105 000	110 000	110 000	140 000	150 000
Minimum tensile strength (MPa)		413	517	655	689	655	689	724	724	862	931
Maximum tensile strength (psi)		60 000	75 000	95 000	100 000	95 000	100 000	105 000	105 000	125 000	135 000

(1) L80 9Cr: 1 red, 1 brown and 2 yellow bands; L80 13Cr: 1 red, 1 brown and 1 yellow bands.

(2) C90 Type 1: 1 purple band; C90 Type 2: 1 purple and 1 yellow bands.

(3) T95 Type 1: 1 silver band; T95 Type 2: 1 silver and 1 yellow bands.

(4) Q125 Type 1: 1 orange band; Q125 Type 2: 1 orange and one yellow band; Q125 Type 3: 1 orange and 1 green band; Q125 Type 4: 1 orange and 1 brown band.

(5) Special clearance couplings shall also be painted with a black band around the center.

Line pipe

(API Standard 5L, April 1, 1995)

Properties	Grade	A25	A	B	X42	X46	X52	X56	X60 (1)	X65 (1)	X70 (1)	X80 (1)
Minimum yield strength (MPa)		172	207	241	289	317	358	386	413	448	482	551
Maximum yield strength (psi)		25 000	30 000	35 000	42 000	46 000	52 000	56 000	60 000	65 000	70 000	80 000
Minimum tensile strength (MPa)		310	331	413	413	434	455	489	517	530	565	620
Maximum tensile strength (psi)		45 000	48 000	60 000	60 000	63 000	66 000	71 000	75 000	77 000	82 000	90 000

(1) Non-weldable.

TENSILE REQUIREMENTS OF SPECIAL STEELS (NON-API) (Vallourec & Mannesmann documentation)

Grade	H ₂ S-resistant						Collapse resistant			
	VM 80SS	VM 90S SS*	VM 95S SS*	VM 100SS	VM 110SS	VM 125SS	VM 80HC	VM 95HC	VM 110HC	VM 125HC
Properties	Red + orange and orange bands	Purple + orange *and orange	Brown + orange *and orange	Black + orange and orange bands	White + orange and orange bands	Yellow + orange and orange bands	Red + green band	Brown + green band	White + green band	Orange + green band
Minimum yield strength (MPa)	551	620	655	690	758	862	551	655	758	862
Maximum yield strength (psi)	80 000	90 000	95 000	100 000	110 000	125 000	80 000	95 000	110 000	125 000
Minimum yield strength (MPa)	655	724	758	792	862	965	758	862	965	1069
Minimum tensile strength (psi)	95 000	105 000	110 000	115 000	125 000	140 000	110 000	125 000	140 000	155 000
Minimum tensile strength (MPa)	655	689	724	758	828	931	689	758	862	931
Minimum tensile strength (psi)	95 000	100 000	105 000	110 000	120 000	135 000	100 000	110 000	125 000	135 000

Grade	Special deep wells					Special arctic (Permafrost)				
	VM80 HCSS	VM 90HCS HCSS*	VM 95HCS HCSS*	VM 110 HCSS	VM 55LT	VM 80LT	VM 95LT	VM 110LT	VM 125LT	
Properties	Red + green orange and orange bands	Purple + green and orange bands	Brown + green and orange bands	White + green orange and orange bands	Green + blue band	Red + blue band	Brown + blue band	White + blue band	Orange + blue band	
Minimum yield strength (MPa)	551	621	655	758	379	551	655	758	862	
Maximum yield strength (psi)	80 000	90 000	95 000	110 000	55 000	80 000	95 000	110 000	125 000	
Minimum yield strength (MPa)	655	724	758	862	551	655	758	965	1034	
Minimum tensile strength (psi)	95 000	105 000	110 000	125 000	80 000	95 000	110 000	140 000	150 000	
Minimum tensile strength (MPa)	655	690	724	828	517	655	724	862	931	
Minimum tensile strength (psi)	95 000	100 000	105 000	120 000	75 000	95 000	105 000	125 000	135 000	

* + orange.

API CASING LIST

(API Specification 5CT, 5th edition, April 1, 1995)

Nominal outside diameter (in)	Nominal weight (lb/ft)	Wall thickness		Type of end finish*						
				Grade						
		(in)	(mm)	H40	J55 K55	L80 C95	N80	C90 T95	P110	Q125
4 1/2	9.50	0.205	5.21	PS	PS PSB PSLB	PLB PLB	PLB PLB	PLB PLB	PLB PLB	PLB
4 1/2	10.50	0.224	5.69							
4 1/2	11.60	0.250	6.35							
4 1/2	13.50	0.290	7.37							
4 1/2	15.10	0.337	8.56							
5	11.50	0.220	5.59		PS PSLB PSLBE	PLBE PLBE PLB PLB PLB	PLBE PLBE PLB PLB PLB	PLBE PLBE PLB PLB PLB	PLBE PLBE PLB PLB PLB	PLBE PLB PLB PLB
5	13.00	0.253	6.43							
5	15.00	0.296	7.52							
5	18.00	0.362	9.19							
5	21.40	0.437	11.10							
5	23.20	0.478	12.14							
5	24.10	0.500	12.70							
5 1/2	14.00	0.244	6.20	PS	PS PSLBE PSLBE	PLBE PLBE PLBE	PLBE PLBE PLBE	PLBE PLBE PLBE	PLBE PLBE PLBE	PLBE
5 1/2	15.50	0.275	6.99							
5 1/2	17.00	0.304	7.72							
5 1/2	20.00	0.361	9.17							
5 1/2	23.00	0.415	10.54							
5 1/2	26.80	0.500	12.70							
5 1/2	29.70	0.562	14.27							
5 1/2	32.60	0.625	15.88							
5 1/2	35.30	0.687	17.45							
5 1/2	38.00	0.750	19.05							
5 1/2	40.50	0.812	20.62							
5 1/2	43.10	0.875	22.23							
6 5/8	20.00	0.288	7.32	PS	PSLB PSLBE	PLBE PLBE PLBE	PLBE PLBE PLBE	PLBE PLBE PLBE	PLBE PLBE PLBE	PLBE
6 5/8	24.00	0.352	8.94							
6 5/8	28.00	0.417	10.59							
6 5/8	32.00	0.475	12.07							
7	17.00	0.231	5.87	PS PS	PS PSLBE PSLBE	PLBE PLBE PLBE PLBE PLBE PLBE PLBE PLBE PLBE	PLBE PLBE PLBE PLBE PLBE PLBE PLBE PLBE PLBE	PLBE PLBE PLBE PLBE PLBE PLBE PLBE PLBE PLBE	PLBE PLBE PLBE PLBE	
7	20.00	0.272	6.91							
7	23.00	0.317	8.05							
7	26.00	0.362	9.19							
7	29.00	0.408	10.36							
7	32.00	0.453	11.51							
7	35.00	0.498	12.65							
7	38.00	0.540	13.72							
7	42.70	0.625	15.88							
7	46.40	0.687	17.45							
7	50.10	0.750	19.05							
7	53.60	0.812	20.62							
7	57.10	0.875	22.23							
7 5/8	24.00	0.300	7.62	PS	PSLBE	PLBE PLBE PLBE PLBE PLBE PLB PLB PLB	PLBE PLBE PLBE PLBE PLBE PLB PLB PLB	PLBE PLBE PLBE PLBE PLBE PLB PLB PLB	PLBE PLBE PLBE PLB PLB PLB	PLBE PLB PLB PLB
7 5/8	26.40	0.328	8.33							
7 5/8	29.70	0.375	9.53							
7 5/8	33.70	0.430	10.92							
7 5/8	39.00	0.500	12.70							
7 5/8	42.80	0.562	14.27							
7 5/8	45.30	0.595	15.11							
7 5/8	47.10	0.625	15.88							
7 5/8	51.20	0.687	17.45							
7 5/8	55.30	0.750	19.05							

* P = plain end; S = short round thread; L = long round thread; B = buttress thread; E = extreme-line.

API CASING LIST (continued)
(API Specification 5CT, 5th edition, April 1, 1995)

Nominal outside diameter (in)	Nominal weight (lb/ft)	Wall thickness		Type of end finish*						
				Grade						
		(in)	(mm)	H40	J55 K55	L80 C95	N80	C90 T95	P110	Q125
7 3/4	46.10	0.595	15.11			P	P	P	P	P
8 5/8	24.00	0.264	6.71	PS PS	PS PSLBE	PLBE PLBE PLBE PLBE	PLBE PLBE PLBE PLBE	PLBE PLBE PLBE PLBE	PLBE PLBE PLBE PLBE	PLBE
8 5/8	28.00	0.304	7.72							
8 5/8	32.00	0.352	8.94							
8 5/8	36.00	0.400	10.16							
8 5/8	40.00	0.450	11.43							
8 5/8	44.00	0.500	12.70							
8 5/8	49.00	0.557	14.15							
9 5/8	32.30	0.312	7.92	PS PS	PSLB PSLBE	PLBE PLBE PLBE PLBE PLB	PLBE PLBE PLBE PLBE PLB	PLBE PLBE PLBE PLBE PLB P P P P	PLBE PLBE PLBE PLB	
9 5/8	36.00	0.352	8.94							
9 5/8	40.00	0.395	10.03							
9 5/8	43.50	0.435	11.05							
9 5/8	47.00	0.472	11.99							
9 5/8	53.50	0.545	13.84							
9 5/8	58.40	0.595	15.11							
9 5/8	59.40	0.609	15.47							
9 5/8	64.90	0.672	17.07							
9 5/8	70.30	0.734	18.64							
9 5/8	75.60	0.797	20.24							
10 3/4	32.75	0.279	7.09	PS PS	PSB PSBE PSBE	PSBE PSBE	PSBE PSBE	PSBE PSBE PSBE PSB P P P	PSBE PSBE PSB	
10 3/4	40.50	0.350	8.89							
10 3/4	45.50	0.400	10.16							
10 3/4	51.00	0.450	11.43							
10 3/4	55.50	0.495	12.57							
10 3/4	60.70	0.545	13.84							
10 3/4	65.70	0.595	15.11							
10 3/4	73.20	0.672	17.07							
10 3/4	79.20	0.734	18.64							
10 3/4	85.30	0.797	20.24							
11 3/4	42.00	0.333	8.46	PS	PSB PSB PSB	PSB P P	PSB P P	PSB P P	PSB P P	
11 3/4	47.00	0.375	9.53							
11 3/4	54.00	0.435	11.05							
11 3/4	60.00	0.489	12.42							
11 3/4	65.00	0.534	13.56							
11 3/4	71.00	0.582	14.78							
13 3/8	48.00	0.330	8.38	PS	PSB PSB PSB	PSB PSB	PSB PSB	PSB PSB	PSB	
13 3/8	54.50	0.380	9.65							
13 3/8	61.00	0.430	10.92							
13 3/8	68.00	0.480	12.19							
13 3/8	72.00	0.514	13.06							
16	65.00	0.375	9.53	PS	PSB PSB P	P	P	P	P	
16	75.00	0.438	11.13							
16	84.00	0.495	12.57							
16	109.00	0.656	16.66							
18 5/8	87.50	0.435	11.05	PS	PSB					
20	94.00	0.438	11.13	PSL	PSLB PSLB PSLB					
20	106.50	0.500	12.70							
20	133.00	0.635	16.13							

* P = plain end; S = short round thread; L = long round thread; B = buttress thread; E = extreme-line.

API TUBING LIST (API Specification 5CT, 5th edition, April 1, 1995)

Nominal outside diameter (in)	Weight designation			Wall thickness		Type of end finish*						
	Non-upset (N) (lb/ft)	External upset (U) (lb/ft)	Integral joint (I) (lb/ft)	(in)	(mm)	Grade						
						H40	J55	L80	N80	C90	T95	P110
1.050	1.14	1.20		0.113	2.87	PNU	PNU	PNU	PNU	PNU	PNU	
1.050	1.48	1.54		0.154	3.91	PU	PU	PU	PU	PU	PU	PU
1.315	1.70	1.80	1.72	0.133	3.38	PNUI	PNUI	PNUI	PNUI	PNUI	PNUI	
1.315	2.19	2.24		0.179	4.55	PU	PU	PU	PU	PU	PU	PU
1.660			2.10	0.125	3.18	PI	PI					
1.660	2.30	2.40	2.33	0.140	3.56	PNUI	PNUI	PNUI	PNUI	PNUI	PNUI	
1.660	3.03	3.07		0.191	4.85	PU	PU	PU	PU	PU	PU	PU
1.900			2.40	0.125	3.18	PI	PI					
1.900	2.75	2.90	2.76	0.145	3.68	PNUI	PNUI	PNUI	PNUI	PNUI	PNUI	
1.900	3.65	3.73		0.200	5.08	PU	PU	P	P	P	P	PU
1.900	4.42			0.250	6.35			P		P	P	
1.900	5.15			0.300	7.62			P		P	P	
2.063			3.25	0.156	3.96	PI	PI	PI	PI	PI	PI	
2.063	4.50			0.225	5.72	P	P	P	P	P	P	P
2.375	4.00			0.167	4.24	PN	PN	PN	PN	PN	PN	
2.375	4.60	4.70		0.190	4.83	PNU	PNU	PNU	PNU	PNU	PNU	
2.375	5.80	5.95		0.254	6.45			PNU	PNU	PNU	PNU	PNU
2.375	6.60			0.295	7.49			P	P	P	P	
2.375	7.35	7.45		0.336	8.53			PU	PU	PU	PU	
2.875	6.40	6.50		0.217	5.51	PNU	PNU	PNU	PNU	PNU	PNU	PNU
2.875	7.80	7.90		0.276	7.01			PNU	PNU	PNU	PNU	PNU
2.875	8.60	8.70		0.308	7.82			PNU	PNU	PNU	PNU	PNU
2.875	9.35	9.45		0.340	8.64			PU	PU	PU	PU	
2.875	10.50			0.392	9.96			P	P	P	P	
2.875	11.50			0.440	11.18			P	P	P	P	
3.500	7.70			0.216	5.49	PN	PN	PN	PN	PN	PN	
3.500	9.20	9.30		0.254	6.45	PNU	PNU	PNU	PNU	PNU	PNU	PNU
3.500	10.20			0.289	7.34	PN	PN	PN	PN	PN	PN	
3.500	12.70	12.95		0.375	9.53			PNU	PNU	PNU	PNU	PNU
3.500	14.30			0.430	10.92			P	P	P	P	
3.500	15.50			0.476	12.09			P	P	P	P	
3.500	17.00			0.530	13.46			P	P	P	P	
4.000	9.50			0.226	5.74	PN	PN	PN	PN	PN	PN	
4.000		11.00		0.262	6.65	PU	PU	PU	PU	PU	PU	
4.000	13.20			0.330	8.38			P	P	P	P	
4.000	16.10			0.415	10.54			P	P	P	P	
4.000	18.90			0.500	12.70			P	P	P	P	
4.000	22.20			0.610	15.49			P	P	P	P	
4.500	12.60	12.75		0.271	6.88	PNU	PNU	PNU	PNU	PNU	PNU	
4.500	15.20			0.337	8.56			P	P	P	P	
4.500	17.00			0.380	9.65			P	P	P	P	
4.500	18.90			0.430	10.92			P	P	P	P	
4.500	21.50			0.500	12.70			P	P	P	P	
4.500	23.70			0.560	14.22			P	P	P	P	
4.500	26.10			0.630	16.00			P	P	P	P	

* P = plain end; N = non-upset T & C; U = external upset T & C; I = integral joint.

DRIFT DIAMETER (API Standard 5CT, 5th edition, April 1, 1995)

All drift testing shall be performed with a drift mandrel containing a cylindrical portion conforming to the requirements shown below. The ends of the drift mandrel extending beyond the specified cylindrical portion shall be shaped to permit easy entry in the pipe. The drift mandrel shall pass freely through pipe by the use of a manual or power drift procedure. In case of dispute, the manual drift procedure shall be used.

Casing diameter (in)	Mandrel length		Mandrel diameter	
	(in)	(mm)	(in)	(mm)
8 5/8 or less	6	152	$d - 1/8$	$d - 3.18$
9 5/8 to 13 3/8	12	305	$d - 5/32$	$d - 3.97$
16 or more	12	305	$d - 3/16$	$d - 4.76$

Tubing diameter (in)	Mandrel length		Mandrel diameter	
	(in)	(mm)	(in)	(mm)
2 7/8 or less	42	1067	$d - 3/32$	$d - 2.38$
3 1/2 or more	42	1067	$d - 1/8$	$d - 3.18$

Example: 7 in (177.8 mm) casing 26.00 lb/ft, wall thickness $t = 9.2$ mm:

$$d = 177.8 - 2 \times 9.2 = 159.4 \text{ mm}$$

Mandrel diameter:

$$d - 3.18 = 159.4 - 3.18 = 156.22 \text{ mm}$$

EFFICIENCY OF A CONNECTION

In this section, the efficiency is the ratio of the critical cross-section of the connection (pin or box end) to the steel cross-section of the pipe body (line 5). It is expressed as a percentage.

The efficiency also represents the ratio of the tension at the yield strength of the connection to the tension at the yield strength of the pipe body (line 11), unless the coupling is of a different grade from the pipe body.

Since the API 5C3 formulas for calculating the strength of API round and buttress joints employ considerations of pull-out and only account for the minimum tensile strength, it is not possible to apply the concept of efficiency to these connections for casings. For API tubings since the strength is calculated at the yield stress, the concept of efficiency can be applied.

An efficiency under 100 means that the connection is weaker than the pipe body.

The efficiency hence serves to calculate three parameters:

a) **The critical cross-section of the joint:** the value in line 5 is multiplied by the efficiency.

Example:

Hydril 511 7 in 29 lb/ft, line 20, efficiency: 60.6

Critical cross-section of Hydril 511:

$$5451 \text{ mm}^2 \times 0.606 = 3303 \text{ mm}^2$$

$$8.45 \text{ in}^2 \times 0.606 = 5.121 \text{ in}^2$$

b) **The tension at yield stress of the joint:** the value in line 11 is multiplied by the efficiency.

Example:

Hydril 511 7 in 29 lb/ft, tension at the yield stress for N80:

$$301 \times 0.606 = 182 \cdot 10^3 \text{ daN}$$

c) **The minimum tensile strength of the joint:** the critical cross-section of the joint is multiplied by the minimum tensile strength (100 000 psi for N80).

Example:

$$\begin{aligned} 5.121 \text{ in}^2 \times 100\,000 &= 512 \cdot 10^3 \text{ lb} \\ &= 228 \cdot 10^3 \text{ daN} \end{aligned}$$

Or the value in line 11 is multiplied by the efficiency and by the ratio of the minimum tensile strength to the yield strength:

$$301 \times 0.606 \times \frac{100\,000}{80\,000} = 228 \cdot 10^3 \text{ daN}$$

MAKE-UP TORQUE

The make-up torques in the tables C 9-C 15, C 16-C 34, C 35-C 79 correspond to the values and recommendations below:

Buttress

In sizes 4 1/2" through 13 3/8", make-up torque values should be determined by carefully noting the torque required to make up each of several connections to the base of the triangle; then using the torque value thus established, make up the balance of the pipe of that particular weight and grade in the string.

For buttress thread sizes 16", 18 5/8" and 20", see API STC or LTC.

API STC or LTC

In sizes 4 1/2" through 13 3/8", values listed are optimum values. The minimum torque should be not below 75 percent of the optimum value. The maximum torque should be not over 125 percent of the optimum value.

In sizes 16", 18 5/8" and 20", values listed are minimum values. Make-up shall be to a position on each connection represented by the thread vanish point on 8-round thread and the base of triangle on buttress thread using the minimum torque.

Grant Prideco

Make-up torque values listed are optimum values. Minimum value is generally 5 to 10 percent below optimum value and maximum value is generally 5 to 10 percent over optimum value.

Hydril

Make-up torque values listed are optimum values for SLX, 511, 533, CS, PH-4, PH-6.

For 563, the torque is a minimum make-up torque and applies to all grades of steel.

For 521, values listed are minimum make-up torque. A field target torque 15 percent over minimum is recommended.

For MAC-II, values listed are minimum make-up torque. A field target torque 10 percent over minimum is recommended.

Vallourec & Mannesmann

Make-up torque values listed are optimum values. Minimum value is 10 percent below optimum value and maximum value is 10 percent over optimum value.

GEOMETRICAL CHARACTERISTICS AND MECHANICAL PROPERTIES OF SMALL-DIAMETER TUBING

		1.050 in		26.7 mm		1.050 in		26.7 mm							
		1.14/1.20 lb/ft		1.66/1.75 daN/m		1.48/1.54 lb/ft		2.16/2.25 daN/m							
Pipe body	1 Nominal size (OD)	1.050 in		26.7 mm		1.050 in		26.7 mm							
	2 Nominal weight	1.14/1.20 lb/ft		1.66/1.75 daN/m		1.48/1.54 lb/ft		2.16/2.25 daN/m							
	3 Wall thickness	0.113 in		2.9 mm		0.154 in		3.9 mm							
	4 Inside diameter	0.824 in		20.9 mm		0.742 in		18.8 mm							
	5 Steel cross-section	0.333 in ²		215 mm ²		0.433 in ²		280 mm ²							
	6 Capacity	0.028 gal/ft		0.34 l/m		0.022 gal/ft		0.28 l/m							
	7 Displacement	0.045 gal/ft		0.56 l/m		0.045 gal/ft		0.56 l/m							
8 Grade	J55	L80	N80	C90	T95	P110	J55	L80	N80	C90	T95	P110			
9 Collapse resistance (MPa)	72.8		105.9		119.2		125.8		145.7		189.8				
10 Internal yield pressure (MPa)	71.4		103.9		116.9		123.4		142.8		194.7				
11 Pipe body yield strength (1000 daN)	8.1		11.8		13.3		14.1		16.3		21.2				
Connection efficiency	12 API Non-Upset	47.8													
	13 API External Upset	100.0													
	14 API Integral Joint	100.0													
	15 Grant Prideco RTS-8	100.0										100.0			
	16 Hydril CS	100.0										100.0			
	17 Vallourec & Mannesmann mini VAM	100.0										100.0			
	Connection characteristics		Make-up torque (daN.m)				Drift API (mm)	ID (mm)	OD (mm)	Make-up torque (daN.m)				Drift API (mm)	ID (mm)
J55			LN80	C90	C95	P110				J55	LN80	C90	C95		
18 API Non-Upset		24	33	35			18.5	33.4				18.5			
		19 API External Upset	81	111	119		18.5	42.2				18.5			
20 API Integral Joint		34	47	47	47	47	18.5	33.7	17.4	17.4	17.4	18.5	33.7	17.4	17.4
		21 Grant Prideco RTS-8	20	30	30	30	18.5	33.0	33.0	33.0	33.0	18.5	33.0	33.0	33.0
22 Hydril CS		34	47	47	47	47	18.5	33.7	17.4	17.4	17.4	18.5	33.7	17.4	17.4
		23 Vallourec & Mannesmann mini VAM	20	30	30	30	18.5	33.0	33.0	33.0	33.0	18.5	33.0	33.0	33.0

MPa x 145 = psi daN x 2.25 = lb daN.m x 7.38 = lb.ft mm x 0.0394 = in

GEOMETRICAL CHARACTERISTICS AND MECHANICAL PROPERTIES OF SMALL-DIAMETER TUBING (continued)

1	Nominal size (OD)	1.315 in		33.4 mm		1.315 in		33.4 mm									
		1.70/1.80 lb/ft		2.48/2.63 daN/m		2.19/2.24 lb/ft		3.20/3.27 daN/m									
Pipe body	2	Nominal weight															
	3	Wall thickness		3.4 mm		0.179 in		4.5 mm									
	4	Inside diameter		26.6 mm		0.957 in		24.3 mm									
	5	Steel cross-section		319 mm ²		0.639 in ²		412 mm ²									
	6	Capacity		0.56 l/m		0.037 gal/ft		0.46 l/m									
	7	Displacement		0.88 l/m		0.071 gal/ft		0.88 l/m									
	8	Grade	J55	L80	N80	C90	T95	P110	J55	L80	N80	C90	T95	P110			
9	Collapse resistance (MPa)	68.9		100.3		112.8		119.1		129.7		145.9		178.4			
		67.1		97.6		109.8		115.9		131.4		147.8		180.7			
		12.1		17.6		19.8		20.9		22.7		25.6		31.3			
10	Internal yield pressure (MPa)	68.9		100.3		112.8		119.1		129.7		145.9		178.4			
		67.1		97.6		109.8		115.9		131.4		147.8		180.7			
		12.1		17.6		19.8		20.9		22.7		25.6		31.3			
11	Pipe body yield strength (1000 daN)	68.9		100.3		112.8		119.1		129.7		145.9		178.4			
		67.1		97.6		109.8		115.9		131.4		147.8		180.7			
		12.1		17.6		19.8		20.9		22.7		25.6		31.3			
Connection efficiency	12	API Non-Upset		55.5													
	13	API External Upset		100.0													
	14	API Integral Joint		80.8													
	15	Grant Prideco RTS-8		100.0													
	16	Hydril CS		100.0													
	17	Vallourec & Mannesmann mini VAM		100.0													
Connection characteristics	18	API Non-Upset		55.5													
		API External Upset		100.0													
		API Integral Joint		80.8													
	19	Grant Prideco RTS-8		100.0													
		Hydril CS		100.0													
		Vallourec & Mannesmann mini VAM		100.0													
	20	API Non-Upset		55.5													
		API External Upset		100.0													
		API Integral Joint		80.8													
		Grant Prideco RTS-8		100.0													
		Hydril CS		100.0													
21	Vallourec & Mannesmann mini VAM		100.0														
	API Non-Upset		55.5														
	API External Upset		100.0														
22	API Integral Joint		80.8														
	Grant Prideco RTS-8		100.0														
	Hydril CS		100.0														
23	Vallourec & Mannesmann mini VAM		100.0														
	API Non-Upset		55.5														
	API External Upset		100.0														

MPa x 145 = psi daN x 2.25 = lb daN.m x 7.38 = lb.ft mm x 0.0394 = in

GEOMETRICAL CHARACTERISTICS AND MECHANICAL PROPERTIES OF SMALL-DIAMETER TUBING (continued)

		1.660 in				42.2 mm				1.660 in				42.2 mm																				
		2.10 lb/ft				3.06 daN/m				2.30/2.40 lb/ft				3.36/3.50 daN/m																				
Pipe body	1	Nominal size (OD)																																
	2	Nominal weight																																
	3	Wall thickness	0.125 in				3.2 mm				0.140 in				3.6 mm																			
	4	Inside diameter	1.410 in				35.8 mm				1.380 in				35.1 mm																			
	5	Steel cross-section	0.603 in ²				389 mm ²				0.669 in ²				431 mm ²																			
	6	Capacity	0.081 gal/ft				1.01 l/m				0.078 gal/ft				0.96 l/m																			
	7	Displacement	0.112 gal/ft				1.40 l/m				0.112 gal/ft				1.40 l/m																			
	8	Grade	J55	L80	N80	C90	T95	P110	J55	L80	N80	C90	T95	P110	J55	L80	N80	C90	T95	P110														
	9	Collapse resistance (MPa)	52.8				76.8				76.8				85.2				85.2															
	10	Internal yield pressure (MPa)	50.0				72.7				72.7				81.4				81.4															
	11	Pipe body yield strength (1000 daN)	14.7				21.5				21.5				23.8				23.8															
	12	API Non-Upset																																
Connection efficiency	13	API External Upset																																
	14	API Integral Joint																																
	15	Grant Prideco RTS-8																																
	16	Hydril CS																																
	17	Vallourec & Mannesmann mini VAM																																
Connection characteristics			J55				LN80				C90				P110				J55				LN80				C90				P110			
			68																47				65				69							
																			94				129				138							
																			68				93				99							
																			61				92				95							
																			50				70				95							

MPa x 145 = psi daN x 2.25 = lb daN.m x 7.38 = lb.ft mm x 0.0394 = in

GEOMETRICAL CHARACTERISTICS AND MECHANICAL PROPERTIES OF SMALL-DIAMETER TUBING (continued)

		1.660 in		42.2 mm		1.900 in		48.3 mm								
		3.03/3.07 lb/ft		4.42/4.48 daN/m		2.40 lb/ft		3.50 daN/m								
Pipe body	1	Nominal size (OD)														
	2	Nominal weight														
	3	Wall thickness	0.191 in		4.9 mm		0.125 in		3.2 mm							
	4	Inside diameter	1.278 in		32.5 mm		1.650 in		41.9 mm							
	5	Steel cross-section	0.881 in ²		569 mm ²		0.697 in ²		450 mm ²							
	6	Capacity	0.067 gal/ft		0.83 l/m		0.111 gal/ft		1.38 l/m							
	7	Displacement	0.112 gal/ft		1.40 l/m		0.147 gal/ft		1.83 l/m							
	8	Grade	J55	L80	N80	C90	T95	P110	J55	L80	N80	C90	T95	P110		
	9	Collapse resistance (MPa)	77.2		112.3		126.4		133.4		154.4		154.4			
	10	Internal yield pressure (MPa)	76.4		111.1		124.9		131.9		152.7		152.7			
	11	Pipe body yield strength (1000 daN)	21.6		31.4		35.3		37.2		43.1		43.1			
	12	API Non-Upset														
Connection efficiency	13	API External Upset														
	14	API Integral Joint														
	15	Grant Prideco RTS-8					100.0						96.4			
	16	Hydril CS					100.0									
	17	Vallourec & Mannesmann mini VAM					100.0									
Connection characteristics	18	API Non-Upset														
	19	API External Upset														
	20	API Integral Joint														
	21	Grant Prideco RTS-8	61	92	95	95	92	48.9	30.9	30.1	79		53.5	39.5		
	22	Hydril CS	61	95	95	95	95	48.9	30.9	30.1						
	23	Vallourec & Mannesmann mini VAM						50.2	30.1	30.1						
			J55	LN80	C90	C95	P110	OD (mm)	ID (mm)	Drift API (mm)	J55	LN80	C90	C95	P110	
		Make-up torque (daN.m)					Make-up torque (daN.m)					Make-up torque (daN.m)				

MPa x 145 = psi daN x 2.25 = lb daN.m x 7.38 = lb.ft mm x 0.0394 = in

GEOMETRICAL CHARACTERISTICS AND MECHANICAL PROPERTIES OF SMALL-DIAMETER TUBING (continued)

1	Nominal size (OD)	1.900 in			48.3 mm			1.900 in			48.3 mm						
		2.75/2.90 lb/ft			4.01/4.23 daN/m			3.65/3.73 lb/ft			5.33/5.44 daN/m						
Pipe body	3	Wall thickness	0.145 in	J55	L80	N80	C90	T95	P110	0.200 in	L80	N80	C90	T95	P110		
	4	Inside diameter	1.610 in	53.5	77.8	77.8	87.0	90.9	102.3	1.500 in	103.9	103.9	116.9	123.4	142.9		
	5	Steel cross-section	0.799 in ²	50.6	73.7	73.7	82.9	87.5	101.3	1.068 in ²	69.9	101.6	114.3	120.7	139.7		
	6	Capacity	0.106 gal/ft	19.6	28.4	28.4	32.0	33.8	39.1	0.092 gal/ft	26.1	38.0	42.8	45.1	52.3		
	7	Displacement	0.147 gal/ft													0.147 gal/ft	
	8	Grade		J55	L80	N80	C90	T95	P110		J55	L80	N80	C90	T95	P110	
	9	Collapse resistance (MPa)															
10	Internal yield pressure (MPa)																
11	Pipe body yield strength (1000 daN)																
Connection efficiency	12	API Non-Upset	59.7														
	13	API External Upset	100.0														
	14	API Integral Joint	84.1														
	15	Grant Prideco RTS-8	100.0														
	16	Hydril CS	100.0														
	17	Vallourec & Mannesmann mini VAM	100.0														
Connection characteristics	18	API Non-Upset															
	19	API External Upset	56	77	83												
	20	API Integral Joint	119	163	176												
	21	Grant Prideco RTS-8	79	108	117												
	22	Hydril CS	92	122	122												
	23	Vallourec & Mannesmann mini VAM	95	122	122												
			60	80	80												

MPa x 145 = psi daN x 2.25 = lb daN.m x 7.38 = lb.ft mm x 0.0394 = in

GEOMETRICAL CHARACTERISTICS AND MECHANICAL PROPERTIES OF SMALL-DIAMETER TUBING (continued)

1	Nominal size (OD)	1.900 in		48.3 mm		1.900 in		48.3 mm				
		4.42 lb/ft		6.45 daN/m		5.15 lb/ft		7.52 daN/m				
Pipe body	3	Wall thickness	0.300 in	7.6 mm	0.300 in	7.6 mm	J55	L80	N80	C90	T95	P110
	4	Inside diameter	1.400 in	35.6 mm	1.400 in	35.6 mm	100.8	146.7	146.7	165.0	174.2	201.7
	5	Steel cross-section	1.296 in ²	836 mm ²	1.296 in ²	836 mm ²	104.8	152.4	152.4	171.5	181.0	209.6
	6	Capacity	0.080 gal/ft	0.99 l/m	0.080 gal/ft	0.99 l/m	36.9	53.7	53.7	60.4	63.7	73.8
	7	Displacement	0.147 gal/ft	1.83 l/m	0.147 gal/ft	1.83 l/m						
	8	Grade	J55	L80	N80	C90	T95	P110				
	9	Collapse resistance (MPa)	86.7	126.1	126.1	141.8	149.7	173.3				
10	Internal yield pressure (MPa)	87.3	127.0	127.0	142.9	150.8	174.6					
11	Pipe body yield strength (1000 daN)	31.7	46.1	46.1	51.9	54.8	63.4					
Connection efficiency	12	API Non-Upset										
	13	API External Upset										
	14	API Integral Joint										
	15	Grant Prideco RTS-8										
	16	Hydril CS										
	17	Vallourec & Mannesmann mini VAM										
	18	API Non-Upset										
Connection characteristics	19	API External Upset										
	20	API Integral Joint										
	21	Grant Prideco RTS-8										
	22	Hydril CS										
	23	Vallourec & Mannesmann mini VAM										
				Make-up torque (daN.m)			Make-up torque (daN.m)			Drift API (mm)		
				J55	LN80	C90	C95	P110	J55	LN80	C90	C95

MPa x 145 = psi daN x 2.25 = lb daN.m x 7.38 = lb.ft mm x 0.0394 = in

GEOMETRICAL CHARACTERISTICS AND MECHANICAL PROPERTIES OF SMALL-DIAMETER TUBING (continued)

1	Nominal size (OD)	2.063 in			52.4 mm			2.063 in			52.4 mm								
		J55	L80	N80	C90	T95	P110	J55	L80	N80	C90	T95	P110						
2	Nominal weight	3.25 lb/ft			4.74 daN/m			4.50 lb/ft			6.57 daN/m								
3	Wall thickness	0.156 in			4.0 mm			0.225 in			5.7 mm								
4	Inside diameter	1.751 in			44.5 mm			1.613 in			41.0 mm								
5	Steel cross-section	0.935 in ²			603 mm ²			1.299 in ²			838 mm ²								
6	Capacity	0.125 gal/ft			1.55 l/m			0.106 gal/ft			1.32 l/m								
7	Displacement	0.174 gal/ft			2.16 l/m			0.174 gal/ft			2.16 l/m								
8	Grade	J55	L80	N80	C90	T95	P110	J55	L80	N80	C90	T95	P110						
9	Collapse resistance (MPa)	53.0			77.1			77.1			107.2								
10	Internal yield pressure (MPa)	50.2			73.0			73.0			105.3								
11	Pipe body yield strength (1000 daN)	22.9			33.3			33.3			46.2								
12	API Non-Upset																		
13	API External Upset																		
14	API Integral Joint				95.3														
15	Grant Prideco RTS-8				100.0						100.0								
16	Hydril CS				100.0						100.0								
17	Vallourec & Mannesmann mini VAM				100.0						100.0								
Connection efficiency		J55			C90			P110			J55			C90			P110		
		LN80			C90			P110			LN80			C90			P110		
Connection characteristics	API Non-Upset																		
	API External Upset																		
	API Integral Joint	100	138	149	137	142	142	137	142	142	137	142	142	137	142	142	137	142	142
	Grant Prideco RTS-8	107	137	142	137	142	142	137	142	142	137	142	142	137	142	142	137	142	142
	Hydril CS	108	142	90	137	142	142	137	142	142	137	142	142	137	142	142	137	142	142
Vallourec & Mannesmann mini VAM	70																		
		J55			C90			P110			J55			C90			P110		
		LN80			C90			P110			LN80			C90			P110		
		LN80			C90			P110			LN80			C90			P110		
		LN80			C90			P110			LN80			C90			P110		
		LN80			C90			P110			LN80			C90			P110		

MPa x 145 = psi daN x 2.25 = lb daN.m x 7.38 = lb.ft mm x 0.0394 = in

GEOMETRICAL CHARACTERISTICS AND MECHANICAL PROPERTIES OF TUBING

		2.375 in				60.3 mm				2.375 in				60.3 mm						
		4 lb/ft				5.84 daN/m				4.60/4.70 lb/ft				6.71/6.86 daN/m						
Pipe body	1	Nominal size (OD)																		
	2	Nominal weight																		
	3	Wall thickness	0.167 in				4.2 mm				0.190 in				4.8 mm					
	4	Inside diameter	2.041 in				51.8 mm				1.995 in				50.7 mm					
	5	Steel cross-section	1.158 in ²				747 mm ²				1.304 in ²				841 mm ²					
	6	Capacity	0.170 gal/ft				2.11 l/m				0.162 gal/ft				2.02 l/m					
	7	Displacement	0.230 gal/ft				2.86 l/m				0.230 gal/ft				2.86 l/m					
	8	Grade	J55	L80	N80	C90	T95	P110	J55	L80	N80	C90	T95	P110	J55	L80	N80	C90	T95	P110
	9	Collapse resistance (MPa)	49.6				68.8				75.4				87.8					
	10	Internal yield pressure (MPa)	46.7				67.9				76.4				93.3					
	11	Pipe body yield strength (1000 daN)	28.3				41.2				46.4				56.7					
	12	API Non-Upset					65.0								68.9					
Connection efficiency	13	API External Upset													100.0					
	14	Grant Prideco CSTCP													100.0					
	15	Grant Prideco STL													44.1					
	16	Grant Prideco TCII													100.0					
	17	Hydril CS													100.0					
	18	Hydril PH4-PH6													100.0					
	19	Vallourec & Mannesmann TDS													100.0					
	20	Vallourec & Mannesmann New VAM													106.8					
	21	Vallourec & Mannesmann VAM ACE													108.9					
	22	Vallourec & Mannesmann VAM PRO													100.0					
	23	Vallourec & Mannesmann FJL													44.9					
Connection characteristics	24	API Non-Upset													49.5					
	25	API External Upset													49.5					
	26	Grant Prideco CSTCP													73.0					
	27	Grant Prideco STL													73.0					
	28	Grant Prideco TCII													73.0					
	29	Hydril CS													73.0					
	30	Hydril PH4-PH6													73.0					
	31	Vallourec & Mannesmann TDS													73.0					
	32	Vallourec & Mannesmann New VAM													73.0					
	33	Vallourec & Mannesmann VAM ACE													73.0					
	34	Vallourec & Mannesmann VAM PRO													73.0					
	35	Vallourec & Mannesmann FJL													73.0					
			J55				LN80				C90				P110					
			83				114				123									
			99				136				146				174					
			175				241				260				308					
			168				229				81				229					
			68				81				81				81					
			169				230				230				230					
			157				216				245				275					
			127				137				146				157					
			79				88				88				94					
			94				88				88				94					

MPa x 145 = psi daN x 2.25 = lb daN.m x 7.38 = lb.ft mm x 0.0394 = in

GEOMETRICAL CHARACTERISTICS AND MECHANICAL PROPERTIES OF TUBING (continued)

1	Nominal size (OD)	2.375 in		60.3 mm		2.375 in		60.3 mm							
		J55	L80	N80	C90	T95	P110	J55	L80	N80	C90	T95	P110		
2	Nominal weight	6.60 lb/ft		9.63 daN/m		7.35/7.45 lb/ft		10.73/10.87 daN/m							
Pipe body	3	Wall thickness	0.295 in	7.5 mm		0.336 in	8.5 mm								
	4	Inside diameter	1.785 in	45.3 mm		1.703 in	43.3 mm								
	5	Steel cross-section	1.928 in ²	1244 mm ²		2.152 in ²	1389 mm ²								
	6	Capacity	0.130 gal/ft	1.61 l/m		0.118 gal/ft	1.47 l/m								
	7	Displacement	0.230 gal/ft	2.86 l/m		0.230 gal/ft	2.86 l/m								
	8	Grade	J55	L80	N80	C90	T95	P110	J55	L80	N80	C90	T95	P110	
	9	Collapse resistance (MPa)	82.5	120.0	120.0	135.0	142.5	165.0	92.1	134.0	134.0	150.7	159.1	184.2	
10	Internal yield pressure (MPa)	82.4	119.9	119.9	134.9	142.4	164.9	93.9	136.6	136.6	153.6	162.2	187.8		
11	Pipe body yield strength (1000 daN)	47.2	68.6	68.6	77.2	81.5	94.3	52.7	76.6	76.6	86.2	91.0	105.3		
Connection efficiency	12	API Non-Upset													
	13	API External Upset													
	14	Grant Prideco CSTCP													
	15	Grant Prideco STL													
	16	Grant Prideco TCII													
	17	Hydril CS													
	18	Hydril PH4-PH6													
	19	Vallourec & Mannesmann TDS													
	20	Vallourec & Mannesmann New VAM													
	21	Vallourec & Mannesmann VAM ACE													
	22	Vallourec & Mannesmann VAM PRO													
23	Vallourec & Mannesmann FJL														
Connection characteristics	24	API Non-Upset													
	25	API External Upset													
	26	Grant Prideco CSTCP													
	27	Grant Prideco STL													
	28	Grant Prideco TCII													
	29	Hydril CS													
	30	Hydril PH4-PH6													
	31	Vallourec & Mannesmann TDS													
	32	Vallourec & Mannesmann New VAM													
	33	Vallourec & Mannesmann VAM ACE													
	34	Vallourec & Mannesmann VAM PRO													
	35	Vallourec & Mannesmann FJL													

MPa x 145 = psi daN x 2.25 = lb daN.m x 7.38 = lb.ft mm x 0.0394 = in

GEOMETRICAL CHARACTERISTICS AND MECHANICAL PROPERTIES OF TUBING (continued)

1	Nominal size (OD)	2.875 in				73.0 mm				2.875 in				73.0 mm						
		6.40/6.50 lb/ft				9.34/9.49 daN/m				7.80/7.90 lb/ft				11.38/11.53 daN/m						
Pipe body	3	Wall thickness	0.217 in	5.5 mm	0.276 in	7.0 mm	0.276 in	7.0 mm	0.276 in	7.0 mm	0.276 in	7.0 mm	0.276 in	7.0 mm	0.276 in	7.0 mm				
	4	Inside diameter	2.441 in	62.0 mm	2.323 in	59.0 mm	2.323 in	59.0 mm	2.323 in	59.0 mm	2.323 in	59.0 mm	2.323 in	59.0 mm	2.323 in	59.0 mm				
	5	Steel cross-section	1.812 in ²	1169 mm ²	2.254 in ²	1454 mm ²	2.254 in ²	1454 mm ²	2.254 in ²	1454 mm ²	2.254 in ²	1454 mm ²	2.254 in ²	1454 mm ²	2.254 in ²	1454 mm ²				
	6	Capacity	0.243 gal/ft	3.02 l/m	0.220 gal/ft	2.73 l/m	0.220 gal/ft	2.73 l/m	0.220 gal/ft	2.73 l/m	0.220 gal/ft	2.73 l/m	0.220 gal/ft	2.73 l/m	0.220 gal/ft	2.73 l/m				
	7	Displacement	0.337 gal/ft	4.19 l/m	0.337 gal/ft	4.19 l/m	0.337 gal/ft	4.19 l/m	0.337 gal/ft	4.19 l/m	0.337 gal/ft	4.19 l/m	0.337 gal/ft	4.19 l/m	0.337 gal/ft	4.19 l/m				
	8	Grade	J55	L80	N80	C90	T95	P110	J55	L80	N80	C90	T95	P110	J55	L80	N80	C90	T95	P110
	9	Collapse resistance (MPa)	52.9	77.0	77.0	85.4	89.2	100.3	65.8	95.7	95.7	107.7	113.7	131.6	63.7	92.7	92.7	104.2	110.0	127.4
10	Internal yield pressure (MPa)	50.1	72.9	72.9	82.0	86.5	100.2	63.7	92.7	92.7	104.2	110.0	127.4	63.7	92.7	92.7	104.2	110.0	127.4	
11	Pipe body yield strength (1000 daN)	44.3	64.5	64.5	72.5	76.6	88.7	55.1	80.2	80.2	90.2	95.2	110.3	55.1	80.2	80.2	90.2	95.2	110.3	
Connection efficiency	12	API Non-Upset	72.8		78.1			78.1						78.1						
	13	API External Upset	100.0		100.0			100.0						100.0						
	14	Grant Prideco CSTCP	100.0		100.0			100.0						100.0						
	15	Grant Prideco STL	49.2		49.2			55.2						55.2						
	16	Grant Prideco TCII	100.0		100.0			100.0						100.0						
	17	Hydril CS	100.0		100.0			100.0						100.0						
	18	Hydril PH4-PH6	100.0		100.0			100.0						100.0						
	19	Vallourec & Mannesmann TDS	100.0		100.0			100.0						100.0						
	20	Vallourec & Mannesmann New VAM	106.3		106.3			107.5						107.5						
	21	Vallourec & Mannesmann VAM ACE	104.4		104.4			106.1						106.1						
	22	Vallourec & Mannesmann VAM PRO	100.0		100.0			100.0						100.0						
	23	Vallourec & Mannesmann FJL	48.9		48.9			52.0						52.0						
	Connection characteristics	24	API Non-Upset	142	197	213	251	88.9	59.6	262	283	335	88.9	56.6	262	283	335	88.9	56.6	
25		API External Upset	224	308	334	395	93.2	59.6	371	403	475	93.2	56.6	371	403	475	93.2	56.6		
26		Grant Prideco CSTCP	229	320	320	320	81.5	59.6	461	461	536	87.3	56.6	461	461	536	87.3	56.6		
27		Grant Prideco STL	95	122	122	122	73.0	59.6	163	163	163	73.0	56.6	163	163	163	73.0	56.6		
28		Grant Prideco TCII	351	351	351	351	81.6	59.6	351	351	351	83.7	56.6	351	351	351	83.7	56.6		
29		Hydril CS	230	319	319	319	81.5	59.6	461	488	536	87.3	56.6	461	488	536	87.3	56.6		
30		Hydril PH4-PH6	236	324	382	431	88.9	59.6	343	392	451	88.9	56.6	343	392	451	88.9	56.6		
31		Vallourec & Mannesmann TDS	197	245	264	294	82.0	59.6	275	304	334	84.8	56.6	275	304	334	84.8	56.6		
32		Vallourec & Mannesmann New VAM	118	118	127	133	81.0	59.6	137	157	176	83.3	56.6	137	157	176	83.3	56.6		
33		Vallourec & Mannesmann VAM ACE					73.0	59.6				73.0	56.6				73.0	56.6		
34		Vallourec & Mannesmann VAM PRO					73.0	59.6				73.0	56.6				73.0	56.6		
35		Vallourec & Mannesmann FJL					73.0	59.6				73.0	56.6				73.0	56.6		

MPa x 145 = psi daN x 2.25 = lb daN.m x 7.38 = lb.ft mm x 0.0394 = in

GEOMETRICAL CHARACTERISTICS AND MECHANICAL PROPERTIES OF TUBING (continued)

1	Nominal size (OD)	2.875 in					73.0 mm									
		J55	L80	N80	C90	T95	P110	J55	L80	N80	C90	T95	P110			
2	Nominal weight	8.60/8.70 lb/ft					12.55/12.70 daN/m					2.875 in 9.35/9.45 lb/ft 13.65/13.79 daN/m				
3	Wall thickness	0.308 in					7.8 mm					0.340 in 8.6 mm				
4	Inside diameter	2.259 in					57.4 mm					2.195 in 55.8 mm				
5	Steel cross-section	2.484 in ²					1602 mm ²					2.708 in ² 1747 mm ²				
6	Capacity	0.208 gal/ft					2.59 l/m					0.197 gal/ft 2.44 l/m				
7	Displacement	0.337 gal/ft					4.19 l/m					0.337 gal/ft 4.19 l/m				
8	Grade	J55	L80	N80	C90	T95	P110	J55	L80	N80	C90	T95	P110			
9	Collapse resistance (MPa)	72.5	105.5	105.5	118.7	125.3	145.1	79.1	115.0	115.0	129.4	136.6	158.2			
10	Internal yield pressure (MPa)	71.1	103.4	103.4	116.3	122.8	142.2	78.5	114.2	114.2	128.4	135.6	157.0			
11	Pipe body yield strength (1000 daN)	60.8	88.4	88.4	99.4	105.0	121.5	66.2	96.4	96.4	108.4	114.4	132.5			
12	API Non-Upset	80.2														
13	API External Upset	100.0														
14	Grant Prideco CSTCP	100.0														
15	Grant Prideco STL	56.6														
16	Grant Prideco TCII	100.0														
17	Hydril CS	100.0														
18	Hydril PH4-PH6	100.0														
19	Vallourec & Mannesmann TDS	100.0														
20	Vallourec & Mannesmann New VAM	103.5														
21	Vallourec & Mannesmann VAM ACE	102.2														
22	Vallourec & Mannesmann VAM PRO	100.0														
23	Vallourec & Mannesmann FJL	55.5														
Connection efficiency		J55					LN80					C90				
		J55	LN80	C90	C95	P110	J55	LN80	C90	C95	P110	J55	LN80	C90	C95	P110
Connection characteristics		296					321					378				
		405	438	461	176	351	461	488	502	536	517	536	536	517	536	
24	API Non-Upset	149					176					55.0				
		351	351	351	351	351	351	351	351	351	351	351	351	351		
25	API External Upset	285					382					55.0				
		294	334	363	363	363	382	441	441	441	441	441	441	441		
26	Grant Prideco CSTCP	176					176					55.0				
		351	351	351	351	351	351	351	351	351	351	351	351	351		
27	Grant Prideco STL	176					176					55.0				
		351	351	351	351	351	351	351	351	351	351	351	351	351		
28	Grant Prideco TCII	176					176					55.0				
		351	351	351	351	351	351	351	351	351	351	351	351	351		
29	Hydril CS	176					176					55.0				
		351	351	351	351	351	351	351	351	351	351	351	351	351		
30	Hydril PH4-PH6	176					176					55.0				
		351	351	351	351	351	351	351	351	351	351	351	351	351		
31	Vallourec & Mannesmann TDS	176					176					55.0				
		351	351	351	351	351	351	351	351	351	351	351	351	351		
32	Vallourec & Mannesmann New VAM	176					176					55.0				
		351	351	351	351	351	351	351	351	351	351	351	351	351		
33	Vallourec & Mannesmann VAM ACE	176					176					55.0				
		351	351	351	351	351	351	351	351	351	351	351	351	351		
34	Vallourec & Mannesmann VAM PRO	176					176					55.0				
		351	351	351	351	351	351	351	351	351	351	351	351	351		
35	Vallourec & Mannesmann FJL	176					176					55.0				
		351	351	351	351	351	351	351	351	351	351	351	351	351		

MPa x 145 = psi daN x 2.25 = lb daN.m x 7.38 = lb.ft mm x 0.0394 = in

GEOMETRICAL CHARACTERISTICS AND MECHANICAL PROPERTIES OF TUBING (continued)

		2.875 in			73.0 mm			2.875 in			73.0 mm					
		9.80 lb/ft			14.30 daN/m			10.50 lb/ft			15.32 daN/m					
Pipe body	1	Nominal size (OD)		J55	L80	N80	C90	T95	P110	J55	L80	N80	C90	T95	P110	
	2	Nominal weight														
	3	Wall thickness		0.362 in			9.2 mm			0.392 in			10.0 mm			
	4	Inside diameter		2.151 in			54.6 mm			2.091 in			53.1 mm			
	5	Steel cross-section		2.858 in ²			1844 mm ²			3.058 in ²			1973 mm ²			
	6	Capacity		0.189 gal/ft			2.34 l/m			0.178 gal/ft			2.22 l/m			
	7	Displacement		0.337 gal/ft			4.19 l/m			0.337 gal/ft			4.19 l/m			
	8	Grade		J55	L80	N80	C90	T95	P110	J55	L80	N80	C90	T95	P110	
	9	Collapse resistance (MPa)		83.5	121.4	121.4	136.6	144.2	166.9	89.3	129.9	129.9	146.1	154.3	178.6	
	10	Internal yield pressure (MPa)		83.6	121.5	121.5	136.7	144.3	167.1	90.5	131.6	131.6	148.1	156.3	181.0	
	11	Pipe body yield strength (1000 daN)		69.9	101.7	101.7	114.4	120.8	139.8	74.8	108.8	108.8	122.4	129.2	149.6	
	12	API Non-Upset														
	13	API External Upset														
	14	Grant Prideco CSTCP														
Connection efficiency	15	Grant Prideco STL														
	16	Grant Prideco TCII														
	17	Hydril CS														
	18	Hydril PH4-PH6														
	19	Vallourec & Mannesmann TDS														
	20	Vallourec & Mannesmann New VAM		103.1												
	21	Vallourec & Mannesmann VAM ACE		102.0												
	22	Vallourec & Mannesmann VAM PRO		100.0												
	23	Vallourec & Mannesmann FJL		55.0												
	Connection characteristics	24	API Non-Upset													
		25	API External Upset													
26		Grant Prideco CSTCP														
27		Grant Prideco STL														
28		Grant Prideco TCII														
29		Hydril CS														
30		Hydril PH4-PH6														
31		Vallourec & Mannesmann TDS														
32		Vallourec & Mannesmann New VAM		324	441	510	510	510	579	87.2	52.3	746	780	841	93.7	51.6
33		Vallourec & Mannesmann VAM ACE		343	422	461	461	491	491	87.0	52.3				88.0	50.7
34		Vallourec & Mannesmann VAM PRO			206	226	226	245	245	85.3	52.3				86.3	50.7
35	Vallourec & Mannesmann FJL								73.0	52.3						

MPa x 145 = psi daN x 2.25 = lb daN.m x 7.38 = lb.ft mm x 0.0394 = in

GEOMETRICAL CHARACTERISTICS AND MECHANICAL PROPERTIES OF TUBING (continued)

1	Nominal size (OD)	2.875 in				73.0 mm				3.500 in				88.9 mm				
		11.50 lb/ft				16.78 daN/m				7.70 lb/ft				11.24 daN/m				
Pipe body	3	Wall thickness	0.440 in		11.2 mm		0.216 in		5.5 mm									
	4	Inside diameter	1.995 in		50.7 mm		3.068 in		77.9 mm									
	5	Steel cross-section	3.366 in ²		2172 mm ²		2.228 in ²		1438 mm ²									
	6	Capacity	0.162 gal/ft		2.02 l/m		0.384 gal/ft		4.77 l/m									
	7	Displacement	0.337 gal/ft		4.19 l/m		0.500 gal/ft		6.21 l/m									
	8	Grade	J55	L80	N80	C90	T95	P110	J55	L80	N80	C90	T95	P110				
	9	Collapse resistance (MPa)	98.3	143.0	143.0	160.9	169.8	196.6	41.2	54.2	54.2	58.9	61.0	67.1				
10	Internal yield pressure (MPa)	101.6	147.7	147.7	166.2	175.4	203.1	41.0	59.6	59.6	67.0	70.7	81.9					
11	Pipe body yield strength (1000 daN)	82.3	119.8	119.8	134.8	142.2	164.7	54.5	79.3	79.3	89.2	94.2	109.0					
Connection efficiency	12	API Non-Upset																
	13	API External Upset																
	14	Grant Prideco CSTCP																
	15	Grant Prideco STL																
	16	Grant Prideco TCI																
	17	Hydril CS																
	18	Hydril PH4-PH6																
	19	Vallourec & Mannesmann TDS																
	20	Vallourec & Mannesmann New VAM																
	21	Vallourec & Mannesmann VAM ACE																
	22	Vallourec & Mannesmann VAM PRO																
23	Vallourec & Mannesmann FJL																	
Connection characteristics	24	API Non-Upset																
	25	API External Upset																
	26	Grant Prideco CSTCP																
	27	Grant Prideco STL																
	28	Grant Prideco TCI																
	29	Hydril CS																
	30	Hydril PH4-PH6																
	31	Vallourec & Mannesmann TDS																
	32	Vallourec & Mannesmann New VAM																
	33	Vallourec & Mannesmann VAM ACE																
	34	Vallourec & Mannesmann VAM PRO																
	35	Vallourec & Mannesmann FJL																

MPa x 145 = psi daN x 2.25 = lb daN.m x 7.38 = lb.ft mm x 0.0394 = in

GEOMETRICAL CHARACTERISTICS AND MECHANICAL PROPERTIES OF TUBING (continued)

1	Nominal size (OD)	3.500 in		88.9 mm		3.500 in		88.9 mm												
		9.20/9.30 lb/ft		13.43/13.57 daN/m		10.20 lb/ft		14.89 daN/m												
Pipe body	3	Wall thickness	0.254 in	6.5 mm	0.289 in	7.3 mm	0.289 in	7.3 mm	0.289 in	7.3 mm										
	4	Inside diameter	2.992 in	76.0 mm	2.922 in	74.2 mm	2.922 in	74.2 mm	2.922 in	74.2 mm										
	5	Steel cross-section	2.590 in ²	1671 mm ²	2.915 in ²	1881 mm ²	2.915 in ²	1881 mm ²	2.915 in ²	1881 mm ²										
	6	Capacity	0.365 gal/ft	4.54 l/m	0.348 gal/ft	4.33 l/m	0.348 gal/ft	4.33 l/m	0.348 gal/ft	4.33 l/m										
	7	Displacement	0.500 gal/ft	6.21 l/m	0.500 gal/ft	6.21 l/m	0.500 gal/ft	6.21 l/m	0.500 gal/ft	6.21 l/m										
	8	Grade	J55	L80	N80	C90	T95	P110	J55	L80	N80	C90	T95	P110						
	9	Collapse resistance (MPa)	51.0	72.6	72.6	79.8	83.3	93.3	57.5	83.6	83.6	94.0	99.2	114.9						
10	Internal yield pressure (MPa)	48.2	70.1	70.1	78.8	83.2	96.3	54.8	79.7	79.7	89.7	94.6	109.6							
11	Pipe body yield strength (1000 daN)	63.4	92.2	92.2	103.7	109.5	126.7	71.3	103.7	103.7	116.7	123.2	142.6							
Connection efficiency	12	API Non-Upset	76.8																	
	13	API External Upset	100.0																	
	14	Grant Prideco CSTCP	100.0																	
	15	Grant Prideco STL	50.0																	
	16	Grant Prideco TCI	100.0																	
	17	Hydril CS	100.0																	
	18	Hydril PH4-PH6	100.0																	
	19	Vallourec & Mannesmann TDS	100.0																	
	20	Vallourec & Mannesmann New VAM	103.4																	
	21	Vallourec & Mannesmann VAM ACE	101.5																	
	22	Vallourec & Mannesmann VAM PRO	100.0																	
	23	Vallourec & Mannesmann FJL	54.8																	
	Connection characteristics	24	API Non-Upset	201		278		301		355		108.0		233		323		108.0		71.0
25		API External Upset	309		430		465		549		114.3		381		458		101.1		72.9	
26		Grant Prideco CSTCP	381		458		217		458		99.4		163		217		88.9		71.0	
27		Grant Prideco STL	163		217		217		217		88.9		380		427		100.1		71.0	
28		Grant Prideco TCI	380		427		427		427		98.7		380		461		99.4		71.0	
29		Hydril CS	380		461		461		461		99.4		380		461		99.4		71.0	
30		Hydril PH4-PH6	380		461		461		461		99.4		380		461		99.4		71.0	
31		Vallourec & Mannesmann TDS	324		441		510		579		107.9		363		500		107.9		71.0	
32		Vallourec & Mannesmann New VAM	334		382		412		441		97.0		422		470		100.6		71.0	
33		Vallourec & Mannesmann VAM ACE	334		382		412		441		97.0		422		470		100.3		71.0	
34		Vallourec & Mannesmann VAM PRO	167		176		176		186		88.9		186		186		88.9		71.0	
35		Vallourec & Mannesmann FJL	167		176		176		186		88.9		186		186		88.9		71.0	

MPa x 145 = psi daN x 2.25 = lb daN.m x 7.38 = lb.ft mm x 0.0394 = in

GEOMETRICAL CHARACTERISTICS AND MECHANICAL PROPERTIES OF TUBING (continued)

1	Nominal size (OD)	3.500 in		88.9 mm		3.500 in		88.9 mm													
		12.70/12.95 lb/ft		18.53/18.90 daN/m		13.70 lb/ft		20.00 daN/m													
Pipe body	2	Nominal weight		88.9 mm		13.70 lb/ft		20.00 daN/m													
	3	Wall thickness		9.5 mm		0.413 in		10.5 mm													
	4	Inside diameter		69.9 mm		2.674 in		67.9 mm													
	5	Steel cross-section		2375 mm ²		4.005 in ²		2584 mm ²													
	6	Capacity		3.83 l/m		0.292 gal/ft		3.62 l/m													
	7	Displacement		6.21 l/m		0.500 gal/ft		6.21 l/m													
	8	Grade	J55	L80	N80	C90	T95	P110	J55	L80	N80	C90	T95	P110							
9	Collapse resistance (MPa)		72.6		105.5		118.7		125.3		145.1		157.9								
	Internal yield pressure (MPa)		71.1		103.4		116.3		122.8		142.2		156.6								
	Pipe body yield strength (1000 daN)		90.1		131.0		147.4		155.6		180.1		196.0								
Connection efficiency	12	API Non-Upset		83.7																	
	13	API External Upset		100.0																	
	14	Grant Prideco CSTCP		100.0																	
	15	Grant Prideco STL		64.7																	
	16	Grant Prideco TCII		100.0																	
	17	Hydril CS																			
	18	Hydril PH4-PH6		100.0																	
	19	Vallourec & Mannesmann TDS		100.0																	
	20	Vallourec & Mannesmann New VAM		103.2																	
	21	Vallourec & Mannesmann VAM ACE		101.8																	
	22	Vallourec & Mannesmann VAM PRO		100.0																	
23	Vallourec & Mannesmann FJL		64.9																		
Connection characteristics	Make-up torque (daN.m)		J55	LN80	C90	C95	P110	Drift API (mm)		Make-up torque (daN.m)		J55	LN80	C90	C95	P110	OD (mm)	ID (mm)	Drift API (mm)		
	24	API Non-Upset		430	466	550	550	108.0	66.7	66.7	66.7	66.7	66.7	66.7	66.7	66.7	66.7	66.7	66.7	66.7	
	25	API External Upset		576	625	736	736	114.3	66.7	66.7	66.7	66.7	66.7	66.7	66.7	66.7	66.7	66.7	66.7	66.7	
	26	Grant Prideco CSTCP		841	841	1071	1071	109.6	66.7	66.7	66.7	66.7	66.7	66.7	66.7	66.7	66.7	66.7	66.7	66.7	
	27	Grant Prideco STL		312	312	312	312	88.9	66.7	66.7	66.7	66.7	66.7	66.7	66.7	66.7	66.7	66.7	66.7	66.7	
	28	Grant Prideco TCII		427	427	427	427	103.2	66.7	66.7	66.7	66.7	66.7	66.7	66.7	66.7	66.7	66.7	66.7	66.7	
	29	Hydril CS																			
	30	Hydril PH4-PH6		841	929	1071	1071	109.6	66.7	66.7	66.7	66.7	66.7	66.7	66.7	66.7	66.7	66.7	66.7	66.7	
	31	Vallourec & Mannesmann TDS		579	667	755	755	107.9	66.7	66.7	66.7	66.7	66.7	66.7	66.7	66.7	66.7	66.7	66.7	66.7	
	32	Vallourec & Mannesmann New VAM		667	716	716	716	103.6	66.7	66.7	66.7	66.7	66.7	66.7	66.7	66.7	66.7	66.7	66.7	66.7	
	33	Vallourec & Mannesmann VAM ACE		667	716	716	716	103.4	66.7	66.7	66.7	66.7	66.7	66.7	66.7	66.7	66.7	66.7	66.7	66.7	
34	Vallourec & Mannesmann VAM PRO		236	264	264	264	102.5	66.7	66.7	66.7	66.7	66.7	66.7	66.7	66.7	66.7	66.7	66.7	66.7		
35	Vallourec & Mannesmann FJL		236	264	264	264	88.9	66.7	66.7	66.7	66.7	66.7	66.7	66.7	66.7	66.7	66.7	66.7	66.7		

MPa x 145 = psi daN x 2.25 = lb daN.m x 7.38 = lb.ft mm x 0.0394 = in

GEOMETRICAL CHARACTERISTICS AND MECHANICAL PROPERTIES OF TUBING (continued)

1	Nominal size (OD)	3.500 in		88.9 mm		3.500 in		88.9 mm					
		14.30 lb/ft		20.87 daN/m		14.70 lb/ft		21.45 daN/m					
Pipe body	3	Wall thickness	0.430 in	10.9 mm	J55	L80	N80	C90	T95	P110	11.4 mm		
	4	Inside diameter	2.640 in	67.1 mm	81.7	118.9	118.9	133.7	141.2	163.5	66.1 mm		
	5	Steel cross-section	4.147 in ²	2676 mm ²	81.5	118.6	118.6	133.4	140.8	163.1	2777 mm ²		
	6	Capacity	0.284 gal/ft	3.53 l/m	101.5	147.6	147.6	166.0	175.3	202.9	3.43 l/m		
	7	Displacement	0.500 gal/ft	6.21 l/m							6.21 l/m		
	8	Grade	J55	L80	N80	C90	T95	P110	J55	L80	N80	C90	T95
	9	Collapse resistance (MPa)	81.7	118.9	118.9	133.7	141.2	163.5	84.8	123.4	123.4	138.8	146.5
Connection efficiency	10	Internal yield pressure (MPa)	81.5	118.6	118.6	133.4	140.8	85.1	123.8	123.8	139.3	147.0	
	11	Pipe body yield strength (1000 daN)	101.5	147.6	147.6	166.0	175.3	202.9	105.3	153.1	153.1	172.3	181.9
	12	API Non-Upset											
	13	API External Upset											
	14	Grant Prideco CSTCP			100.0								
Connection characteristics	15	Grant Prideco STL											
	16	Grant Prideco TCII											
	17	Hydril CS											
	18	Hydril PH4-PH6											
	19	Vallourec & Mannesmann TDS											
	20	Vallourec & Mannesmann New VAM			101.9								
	21	Vallourec & Mannesmann VAM ACE			100.0								
	22	Vallourec & Mannesmann VAM PRO											
	23	Vallourec & Mannesmann FJL											
	24	API Non-Upset											
25	API External Upset												
26	Grant Prideco CSTCP												
27	Grant Prideco STL												
28	Grant Prideco TCII												
29	Hydril CS												
30	Hydril PH4-PH6												
31	Vallourec & Mannesmann TDS												
32	Vallourec & Mannesmann New VAM												
33	Vallourec & Mannesmann VAM ACE												
34	Vallourec & Mannesmann VAM PRO												
35	Vallourec & Mannesmann FJL												

MPa x 145 = psi daN x 2.25 = lb daN.m x 7.38 = lb.ft mm x 0.0394 = in

GEOMETRICAL CHARACTERISTICS AND MECHANICAL PROPERTIES OF TUBING (continued)

1	Nominal size (OD)	3.500 in			88.9 mm			3.500 in			88.9 mm			
		15.50 lb/ft			22.62 daN/m			17.00 lb/ft			24.81 daN/m			
2	Nominal weight	0.476 in 2.548 in 4.522 in ² 0.265 gal/ft 0.500 gal/ft			12.1 mm 64.7 mm 2917 mm ² 3.29 l/m 6.21 l/m			0.530 in 2.440 in 4.945 in ² 0.243 gal/ft 0.500 gal/ft			13.5 mm 62.0 mm 3190 mm ² 3.02 l/m 6.21 l/m			
3	Wall thickness	J55	L80	N80	C90	T95	P110	J55	L80	N80	C90	T95	P110	
4	Inside diameter	89.1	129.6	129.6	145.8	153.9	178.2	97.5	141.8	141.8	159.5	168.3	194.9	
5	Steel cross-section	90.3	131.3	131.3	147.7	155.9	180.5	100.5	146.2	146.2	164.4	173.6	201.0	
6	Capacity	110.6	160.9	160.9	181.0	191.1	221.3	121.0	176.0	176.0	198.0	209.0	242.0	
7	Displacement	100.0												
8	Grade	100.0												
9	Collapse resistance (MPa)	100.0												
10	Internal yield pressure (MPa)	103.0												
11	Pipe body yield strength (1000 daN)	101.7												
12	API Non-Upset	100.0												
13	API External Upset	68.0												
14	Grant Prideco CSTCP	100.0												
15	Grant Prideco STL	100.0												
16	Grant Prideco TCII	100.0												
17	Hydril CS	100.0												
18	Hydril PH4-PH6	100.0												
19	Vallourec & Mannesmann TDS	100.0												
20	Vallourec & Mannesmann New VAM	100.0												
21	Vallourec & Mannesmann VAM ACE	100.0												
22	Vallourec & Mannesmann VAM PRO	100.0												
23	Vallourec & Mannesmann FJL	100.0												
24	API Non-Upset	J55			C90			C95			P110			Drift API (mm)
		LN80	C90	C90	C90	C95	C95	P110	LN80	C90	C95	P110	OD (mm)	
25	API External Upset	312			393			427			1071			61.5
26	Grant Prideco CSTCP	841			841			976			1071			61.5
27	Grant Prideco STL	393			427			427			393			61.5
28	Grant Prideco TCII	427			427			427			427			61.5
29	Hydril CS	841			841			929			1071			61.5
30	Hydril PH4-PH6	804			883			883			1029			61.5
31	Vallourec & Mannesmann TDS	883			980			980			1079			61.5
32	Vallourec & Mannesmann New VAM	294			324			324			373			61.5
33	Vallourec & Mannesmann VAM ACE	588			883			883			1029			61.5
34	Vallourec & Mannesmann VAM PRO	785			980			980			1079			61.5
35	Vallourec & Mannesmann FJL	294			324			324			373			61.5

MPa x 145 = psi daN x 2.25 = lb daN.m x 7.38 = lb.ft mm x 0.0394 = in

GEOMETRICAL CHARACTERISTICS AND MECHANICAL PROPERTIES OF TUBING (continued)

1	Nominal size (OD)	4.000 in				101.6 mm									
		J55	L80	N80	C90	T95	P110	J55	L80	N80	C90	T95	P110		
2	Nominal weight	9.50 lb/ft				13.86 daN/m				16.05 daN/m					
3	Wall thickness	0.226 in				5.7 mm				6.7 mm					
4	Inside diameter	3.548 in				90.1 mm				88.3 mm					
5	Steel cross-section	2.680 in ²				1729 mm ²				1985 mm ²					
6	Capacity	0.514 gal/ft				6.38 l/m				6.12 l/m					
7	Displacement	0.653 gal/ft				8.11 l/m				8.11 l/m					
8	Grade	J55	L80	N80	C90	T95	P110	J55	L80	N80	C90	T95	P110		
9	Collapse resistance (MPa)	35.3	45.4	45.4	48.8	50.4	54.5	45.5	60.7	60.7	66.2	68.8	76.2		
10	Internal yield pressure (MPa)	37.5	54.5	54.5	61.4	64.8	75.0	43.5	63.2	63.2	71.1	75.1	86.9		
11	Pipe body yield strength (1000 daN)	65.6	95.4	95.4	107.3	113.2	131.1	75.3	109.5	109.5	123.2	130.0	150.5		
12	API Non-Upset	67.2													
13	API External Upset	100.0													
14	Grant Prideco CSTCP	100.0													
15	Grant Prideco STL	55.1													
16	Grant Prideco TCII	100.0													
17	Hydril CS	100.0													
18	Hydril PH4-PH6	100.0													
19	Vallourec & Mannesmann TDS	100.0													
20	Vallourec & Mannesmann New VAM	103.8													
21	Vallourec & Mannesmann VAM ACE	101.9													
22	Vallourec & Mannesmann VAM PRO	100.0													
23	Vallourec & Mannesmann FJL	54.8													
Connection efficiency		Make-up torque (daN.m)				Drift API (mm)				Make-up torque (daN.m)				Drift API (mm)	
		J55	LN80	C90	C95	P110	OD (mm)	ID (mm)	J55	LN80	C90	C95	P110	OD (mm)	ID (mm)
Connection characteristics		165	230	264		120.7	86.9	347	485	525		127.0	85.1		
		149	190	190	190	190	88.1	86.9	458	534		534	85.1		
		392	540	628	628	706	86.9	176	217	217	217	217	86.0		
		343	392	441	441	491	89.8	86.9	488	488	488	488	86.0		
		176	206	206	206	236	86.9	461	536	536	536	536	85.1		
		392	540	628	628	706	88.3	86.9	412	559	647	647	88.3		
		343	392	441	441	491	86.9	441	519	569	569	618	85.1		
		176	206	206	206	236	88.4	86.9	195	216	216	245	111.4		
							86.9						85.1		

MPa x 145 = psi daN x 2.25 = lb daN.m x 7.38 = lb.ft mm x 0.0394 = in

GEOMETRICAL CHARACTERISTICS AND MECHANICAL PROPERTIES OF TUBING (continued)

Pipe body	Nominal size (OD)		4,000 in		101.6 mm		4,000 in		101.6 mm					
			13.20 lb/ft		19.26 daN/m		14.80 lb/ft		21.60 daN/m					
Pipe body	3	Wall thickness	0.330 in	8.4 mm	8.4 mm	0.380 in	9.7 mm	0.380 in	9.7 mm	0.380 in	9.7 mm			
	4	Inside diameter	3.340 in	84.8 mm	84.8 mm	3.240 in	82.3 mm	3.240 in	82.3 mm	3.240 in	82.3 mm			
	5	Steel cross-section	3.805 in ²	2455 mm ²	2455 mm ²	4.322 in ²	2788 mm ²	4.322 in ²	2788 mm ²	4.322 in ²	2788 mm ²			
	6	Capacity	0.455 gal/ft	5.65 l/m	5.65 l/m	0.428 gal/ft	5.32 l/m	0.428 gal/ft	5.32 l/m	0.428 gal/ft	5.32 l/m			
	7	Displacement	0.653 gal/ft	8.11 l/m	8.11 l/m	0.653 gal/ft	8.11 l/m	0.653 gal/ft	8.11 l/m	0.653 gal/ft	8.11 l/m			
	8	Grade	J55	L80	N80	C90	T95	P110	J55	L80	N80	C90	T95	P110
	9	Collapse resistance (MPa)	57.4	83.5	83.5	93.9	99.2	114.8	65.2	94.8	94.8	106.7	112.6	130.4
Pipe body	10	Internal yield pressure (MPa)	54.7	79.6	79.6	89.6	94.6	109.5	63.0	91.7	91.7	103.2	108.9	126.1
	11	Pipe body yield strength (1000 daN)	93.1	135.4	135.4	152.3	160.8	186.2	105.7	153.8	153.8	173.0	182.6	211.5
	12	API Non-Upset												
Connection efficiency	13	API External Upset												
	14	Grant Prideco CSTCP				100.0								
	15	Grant Prideco STL				58.4								
	16	Grant Prideco TCI				100.0								
	17	Hydril CS												
	18	Hydril PH4-PH6				100.0								
	19	Vallourec & Mannesmann TDS												
	20	Vallourec & Mannesmann New VAM				103.9								
	21	Vallourec & Mannesmann VAM ACE				102.0								
	22	Vallourec & Mannesmann VAM PRO				100.0								
	23	Vallourec & Mannesmann FJL				55.0								
Connection characteristics	24	API Non-Upset												
	25	API External Upset												
	26	Grant Prideco CSTCP				1071								
	27	Grant Prideco STL	227	285	285	285	83.2	81.7						
	28	Grant Prideco TCI		488	488	488	86.4	81.7						
	29	Hydril CS												
	30	Hydril PH4-PH6		841	929	976	83.2	81.7						
	31	Vallourec & Mannesmann TDS				1071								
	32	Vallourec & Mannesmann New VAM	470	647	746	843	81.7	81.7	588	813	941	1079	117.0	79.1
	33	Vallourec & Mannesmann VAM ACE	491	588	637	686	81.7	81.7	637	765	834	912	117.0	79.1
	34	Vallourec & Mannesmann VAM PRO					82.8	81.7						
	35	Vallourec & Mannesmann FJL		304	343	373	81.7	81.7		353	382	412	101.6	79.1

MPa x 145 = psi daN x 2.25 = lb daN.m x 7.38 = lb.ft mm x 0.0394 = in

GEOMETRICAL CHARACTERISTICS AND MECHANICAL PROPERTIES OF TUBING (continued)

1	Nominal size (OD)	4.000 in				101.6 mm											
		J55	L80	N80	C90	T95	P110	J55	L80	N80	C90	T95	P110				
2	Nominal weight	16.10 lb/ft				23.50 daN/m				24.08 daN/m							
3	Wall thickness	0.415 in				10.5 mm				10.9 mm							
4	Inside diameter	3.170 in				80.5 mm				79.8 mm							
5	Steel cross-section	4.674 in ²				3015 mm ²				3111 mm ²							
6	Capacity	0.410 gal/ft				5.09 l/m				5.00 l/m							
7	Displacement	0.653 gal/ft				8.11 l/m				8.11 l/m							
8	Grade	J55	L80	N80	C90	T95	P110	J55	L80	N80	C90	T95	P110				
9	Collapse resistance (MPa)	70.5	102.6	102.6	115.4	121.8	141.0	72.8	105.8	105.8	119.1	125.7	145.5				
10	Internal yield pressure (MPa)	68.9	100.1	100.1	112.7	118.9	137.7	71.3	103.8	103.8	116.7	123.2	142.7				
11	Pipe body yield strength (1000 daN)	114.3	166.3	166.3	187.1	197.5	228.7	118.0	171.6	171.6	193.1	203.8	236.0				
12	API Non-Upset	100.0															
13	API External Upset	102.0															
14	Grant Prideco CSTCP	100.0															
15	Grant Prideco STL	102.8															
16	Grant Prideco TCI	101.5															
17	Hydril CS	100.0															
18	Hydril PH4-PH6	64.5															
19	Vallourec & Mannesmann TDS	102.8															
20	Vallourec & Mannesmann New VAM	101.5															
21	Vallourec & Mannesmann VAM ACE	100.0															
22	Vallourec & Mannesmann VAM PRO	64.5															
23	Vallourec & Mannesmann FJL	100.0															
24	API Non-Upset	J55				LN80				C90				P110			
		J55	LN80	C90	P110	J55	LN80	C90	P110	J55	LN80	C90	P110	J55	LN80	C90	P110
25	API External Upset	100.0															
26	Grant Prideco CSTCP	102.8															
27	Grant Prideco STL	101.5															
28	Grant Prideco TCI	100.0															
29	Hydril CS	64.5															
30	Hydril PH4-PH6	102.8															
31	Vallourec & Mannesmann TDS	101.5															
32	Vallourec & Mannesmann New VAM	100.0															
33	Vallourec & Mannesmann VAM ACE	64.5															
34	Vallourec & Mannesmann VAM PRO	102.8															
35	Vallourec & Mannesmann FJL	101.5															
Connection efficiency	Connection characteristics	J55				LN80				C90				P110			
		J55	LN80	C90	P110	J55	LN80	C90	P110	J55	LN80	C90	P110	J55	LN80	C90	P110
24	API Non-Upset	841				929				976				1071			
25	API External Upset	77.3															
26	Grant Prideco CSTCP	78.2															
27	Grant Prideco STL	77.3															
28	Grant Prideco TCI	77.3															
29	Hydril CS	77.3															
30	Hydril PH4-PH6	77.3															
31	Vallourec & Mannesmann TDS	77.3															
32	Vallourec & Mannesmann New VAM	77.3															
33	Vallourec & Mannesmann VAM ACE	77.3															
34	Vallourec & Mannesmann VAM PRO	77.3															
35	Vallourec & Mannesmann FJL	77.3															

MPa x 145 = psi daN x 2.25 = lb daN.m x 7.38 = lb.ft mm x 0.0394 = in

GEOMETRICAL CHARACTERISTICS AND MECHANICAL PROPERTIES OF TUBING (continued)

1	Nominal size (OD)	4.000 in				101.6 mm											
		18.90 lb/ft				27.58 daN/m											
2	Nominal weight	0.500 in				12.7 mm											
3	Wall thickness	3.000 in				76.2 mm											
4	Inside diameter	5.498 in ²				3547 mm ²											
5	Steel cross-section	0.367 gal/ft				4.56 l/m											
6	Capacity	0.653 gal/ft				8.11 l/m											
7	Displacement	J55	L80	N80	C90	T95	P110	J55	L80	N80	C90	T95	P110				
8	Grade	83.0	120.7	120.7	135.7	143.3	165.9	98.0	142.6	142.6	160.4	169.3	196.0				
9	Collapse resistance (MPa)	83.0	120.7	120.7	135.7	143.3	165.9	101.2	147.2	147.2	165.6	174.8	202.4				
10	Internal yield pressure (MPa)	134.5	195.6	195.6	220.1	232.3	269.0	158.9	231.2	231.2	260.1	274.5	317.9				
11	Pipe body yield strength (1000 daN)	100.0															
12	API Non-Upset	102.2															
13	API External Upset	100.0															
14	Grant Prideco CSTCP	100.0															
15	Grant Prideco STL	100.0															
16	Grant Prideco TCII	100.0															
17	Hydril CS	100.0															
18	Hydril PH4-PH6	100.0															
19	Vallourec & Mannesmann TDS	100.0															
20	Vallourec & Mannesmann New VAM	100.0															
21	Vallourec & Mannesmann VAM ACE	100.0															
22	Vallourec & Mannesmann VAM PRO	100.0															
23	Vallourec & Mannesmann FJL	100.0															
24	API Non-Upset	1295				1417				1478				1600			
		956				1029				1029				1125			
25	API External Upset	883				1029				1029				1125			
26	Grant Prideco CSTCP	883				1029				1029				1125			
27	Grant Prideco STL	883				1029				1029				1125			
28	Grant Prideco TCII	883				1029				1029				1125			
29	Hydril CS	883				1029				1029				1125			
30	Hydril PH4-PH6	883				1029				1029				1125			
31	Vallourec & Mannesmann TDS	883				1029				1029				1125			
32	Vallourec & Mannesmann New VAM	883				1029				1029				1125			
33	Vallourec & Mannesmann VAM ACE	883				1029				1029				1125			
34	Vallourec & Mannesmann VAM PRO	883				1029				1029				1125			
35	Vallourec & Mannesmann FJL	883				1029				1029				1125			
Pipe body	Nominal weight	0.610 in				15.5 mm				32.40 daN/m							
		2.780 in				70.6 mm				32.40 daN/m							
Pipe body	Nominal weight	6.496 in ²				4191 mm ²				32.40 daN/m							
		0.315 gal/ft				3.92 l/m				32.40 daN/m							
Pipe body	Displacement	0.653 gal/ft				8.11 l/m				32.40 daN/m							
		0.653 gal/ft				8.11 l/m				32.40 daN/m							
Connection efficiency	API External Upset	100.0				100.0				100.0							
		102.2				102.2				102.2							
Connection efficiency	Grant Prideco CSTCP	100.0				100.0				100.0							
		100.0				100.0				100.0							
Connection efficiency	Grant Prideco STL	100.0				100.0				100.0							
		100.0				100.0				100.0							
Connection efficiency	Grant Prideco TCII	100.0				100.0				100.0							
		100.0				100.0				100.0							
Connection efficiency	Hydril CS	100.0				100.0				100.0							
		100.0				100.0				100.0							
Connection efficiency	Hydril PH4-PH6	100.0				100.0				100.0							
		100.0				100.0				100.0							
Connection efficiency	Vallourec & Mannesmann TDS	100.0				100.0				100.0							
		100.0				100.0				100.0							
Connection efficiency	Vallourec & Mannesmann New VAM	100.0				100.0				100.0							
		100.0				100.0				100.0							
Connection efficiency	Vallourec & Mannesmann VAM ACE	100.0				100.0				100.0							
		100.0				100.0				100.0							
Connection efficiency	Vallourec & Mannesmann VAM PRO	100.0				100.0				100.0							
		100.0				100.0				100.0							
Connection efficiency	Vallourec & Mannesmann FJL	100.0				100.0				100.0							
		100.0				100.0				100.0							
Connection characteristics	API Non-Upset	1451				1573				1634				1756			
		1451				1573				1634				1756			
Connection characteristics	API External Upset	73.0				74.2				73.0				73.0			
		73.0				73.0				73.0				73.0			
Connection characteristics	Grant Prideco CSTCP	120.5				127.0				120.5				123.9			
		118.6				127.0				120.5				123.9			
Connection characteristics	Grant Prideco STL	120.5				127.0				120.5				123.9			
		118.6				127.0				120.5				123.9			
Connection characteristics	Grant Prideco TCII	120.5				127.0				120.5				123.9			
		118.6				127.0				120.5				123.9			
Connection characteristics	Hydril CS	120.5				127.0				120.5				123.9			
		118.6				127.0				120.5				123.9			
Connection characteristics	Hydril PH4-PH6	120.5				127.0				120.5				123.9			
		118.6				127.0				120.5				123.9			
Connection characteristics	Vallourec & Mannesmann TDS	120.5				127.0				120.5				123.9			
		118.6				127.0				120.5				123.9			
Connection characteristics	Vallourec & Mannesmann New VAM	120.5				127.0				120.5				123.9			
		118.6				127.0				120.5				123.9			
Connection characteristics	Vallourec & Mannesmann VAM ACE	120.5				127.0				120.5				123.9			
		118.6				127.0				120.5				123.9			
Connection characteristics	Vallourec & Mannesmann VAM PRO	120.5				127.0				120.5				123.9			
		118.6				127.0				120.5				123.9			
Connection characteristics	Vallourec & Mannesmann FJL	120.5				127.0				120.5				123.9			
		118.6				127.0				120.5				123.9			

MPa x 145 = psi daN x 2.25 = lb daN.m x 7.38 = lb.ft mm x 0.0394 = in

GEOMETRICAL CHARACTERISTICS AND MECHANICAL PROPERTIES OF TUBING (continued)

Pipe body	Nominal size (OD)		4.500 in		114.3 mm		4.500 in		114.3 mm					
	Nominal weight		12.60/12.75 lb/ft		18.39/18.61 daN/m		15.20 lb/ft		22.18 daN/m					
Pipe body	3	Wall thickness	0.271 in		6.9 mm		0.337 in		8.6 mm					
	4	Inside diameter	3.958 in		100.5 mm		3.826 in		97.2 mm					
	5	Steel cross-section	3.600 in ²		2323 mm ²		4.407 in ²		2844 mm ²					
	6	Capacity	0.639 gal/ft		7.94 l/m		0.597 gal/ft		7.42 l/m					
	7	Displacement	0.826 gal/ft		10.26 l/m		0.826 gal/ft		10.26 l/m					
	8	Grade	J55	L80	N80	C90	T95	P110	J55	L80	N80	C90	T95	P110
	9	Collapse resistance (MPa)	39.5	51.7	51.7	56.0	58.0	63.5	52.5	76.4	76.4	84.3	88.0	98.9
10	Internal yield pressure (MIPa)	40.0	58.1	58.1	65.4	69.0	79.9	49.7	72.3	72.3	81.3	85.8	99.4	
11	Pipe body yield strength (1000 daN)	88.1	128.1	128.1	144.1	152.1	176.2	107.8	156.8	156.8	176.4	186.2	215.7	
Connection efficiency	12	API Non-Upset												
	13	API External Upset												
	14	Grant Prideco CSTCP												
	15	Grant Prideco STL												
	16	Grant Prideco TCII												
	17	Hydril CS												
	18	Hydril PH4-PH6												
	19	Vallourec & Mannesmann TDS												
	20	Vallourec & Mannesmann New VAM												
	21	Vallourec & Mannesmann VAM ACE												
	22	Vallourec & Mannesmann VAM PRO												
23	Vallourec & Mannesmann FJL													
Connection characteristics	24	API Non-Upset	236	328	357									
	25	API External Upset	388	540	587									
	26	Grant Prideco CSTCP	534	686		686								
	27	Grant Prideco STL	203	258	258	258	258	258	258	339	339	339	339	
	28	Grant Prideco TCII		549	549	549	549	549	549	549	549	549	549	
	29	Hydril CS	536	685	685	685	685	685	685	685	685	685	685	
	30	Hydril PH4-PH6												
	31	Vallourec & Mannesmann TDS												
	32	Vallourec & Mannesmann New VAM	480	647	746	834	100.5	97.4	569	785	902	1029	127.3	94.0
	33	Vallourec & Mannesmann VAM ACE	441	491	540	588	124.3	97.4	588	735	785	834	127.1	94.0
	34	Vallourec & Mannesmann VAM PRO					124.9	97.4					125.3	94.0
	35	Vallourec & Mannesmann FJL		304	334	373	114.3	97.4	343	373	373	412	114.3	94.0

MPa x 145 = psi daN x 2.25 = lb daN.m x 7.38 = lb.ft mm x 0.0394 = in

GEOMETRICAL CHARACTERISTICS AND MECHANICAL PROPERTIES OF TUBING (continued)

1	Nominal size (OD)	4,500 in					114.3 mm					4,500 in					114.3 mm				
		17.00 lb/ft					24.81 daN/m					18.90 lb/ft					27.58 daN/m				
Pipe body	3	Wall thickness	0.380 in	9.7 mm						10.9 mm											
	4	Inside diameter	3.740 in	95.0 mm						92.5 mm											
	5	Steel cross-section	4.918 in ²	3173 mm ²						3547 mm ²											
	6	Capacity	0.571 gal/ft	7.09 l/m						6.71 l/m											
	7	Displacement	0.826 gal/ft	10.26 l/m						10.26 l/m											
	8	Grade	J55	L80	N80	C90	T95	P110	J55	L80	N80	C90	T95	P110							
	9	Collapse resistance (MPa)	58.6	85.3	85.3	96.0	101.3	117.3	65.5	95.3	95.3	107.3	113.2	131.1							
10	Internal yield pressure (MPa)	56.0	81.5	81.5	91.7	96.8	112.1	63.4	92.2	92.2	103.8	109.5	126.8								
11	Pipe body yield strength (1000 daN)	120.3	175.0	175.0	196.9	207.8	240.7	134.5	195.7	195.7	220.1	232.3	269.0								
Connection efficiency	12	API Non-Upset																			
	13	API External Upset																			
	14	Grant Prideco CSTCP																			
	15	Grant Prideco STL																			
	16	Grant Prideco TCII																			
	17	Hydriil CS																			
	18	Hydriil PH4-PH6																			
	19	Vallourec & Mannesmann TDS																			
	20	Vallourec & Mannesmann New VAM																			
	21	Vallourec & Mannesmann VAM ACE																			
22	Vallourec & Mannesmann VAM PRO																				
23	Vallourec & Mannesmann FJL																				
Connection characteristics		Make-up torque (daN.m)					Drift API (mm)					Make-up torque (daN.m)					Drift API (mm)				
		J55	LN80	C90	C95	P110	OD (mm)	ID (mm)	J55	LN80	C90	C95	P110	OD (mm)	ID (mm)						
	24	API Non-Upset																			
	25	API External Upset																			
	26	Grant Prideco CSTCP																			
	27	Grant Prideco STL																			
	28	Grant Prideco TCII																			
	29	Hydriil CS																			
	30	Hydriil PH4-PH6	1024	1132	1173	1281	132.3	92.7	1146	1268	1329	1451	135.0	90.4							
	31	Vallourec & Mannesmann TDS																			
	32	Vallourec & Mannesmann New VAM	686	941	1079	1227	127.0	95.0	961	1125	1125	1274	127.0	92.5							
	33	Vallourec & Mannesmann VAM ACE	735	883	931	980	129.7	91.8	1029	1125	1125	1227	132.1	89.3							
34	Vallourec & Mannesmann VAM PRO																				
35	Vallourec & Mannesmann FJL	373	412	412	451	127.0	91.8	403	442	442	500	128.8	89.3								

MPa x 145 = psi daN x 2.25 = lb daN.m x 7.38 = lb.ft mm x 0.0394 = in

GEOMETRICAL CHARACTERISTICS AND MECHANICAL PROPERTIES OF TUBING (continued)

1	Nominal size (OD)	4.500 in					114.3 mm														
		J55	L80	N80	C90	P110	J55	L80	N80	C90	P110										
2	Nominal weight	21.50 lb/ft					31.38 daN/m					4.500 in					114.3 mm				
3	Wall thickness	0.500 in					12.7 mm					23.70 lb/ft					34.59 daN/m				
4	Inside diameter	3.500 in					88.9 mm					0.560 in					14.2 mm				
5	Steel cross-section	6.283 in ²					4054 mm ²					3.380 in					85.9 mm				
6	Capacity	0.500 gal/ft					6.21 l/m					6.932 in ²					4472 mm ²				
7	Displacement	0.826 gal/ft					10.26 l/m					0.466 gal/ft					5.79 l/m				
8	Grade	J55	L80	N80	C90	P110	J55	L80	N80	C90	P110	J55	L80	N80	C90	P110	J55	L80	N80	C90	P110
9	Collapse resistance (MPa)	74.9					122.6					82.6					135.2				
10	Internal yield pressure (MPa)	73.7					120.7					82.6					135.1				
11	Pipe body yield strength (1000 daN)	153.7					251.5					169.6					277.5				
12	API Non-Upset																				
13	API External Upset																				
14	Grant Prideco CSTCP																				
15	Grant Prideco STL																				
16	Grant Prideco TCII																				
17	Hydril CS																				
18	Hydril PH4-PH6																				
19	Vallourec & Mannesmann TDS																				
20	Vallourec & Mannesmann New VAM																				
21	Vallourec & Mannesmann VAM ACE																				
22	Vallourec & Mannesmann VAM PRO																				
23	Vallourec & Mannesmann FJL																				
24	API Non-Upset	J55					P110					J55					P110				
		LN80					C90					LN80					C90				
25	API External Upset																				
26	Grant Prideco CSTCP																				
27	Grant Prideco STL																				
28	Grant Prideco TCII																				
29	Hydril CS																				
30	Hydril PH4-PH6																				
31	Vallourec & Mannesmann TDS																				
32	Vallourec & Mannesmann New VAM																				
33	Vallourec & Mannesmann VAM ACE																				
34	Vallourec & Mannesmann VAM PRO																				
35	Vallourec & Mannesmann FJL																				
Connection efficiency																					
Connection characteristics		J55					P110					J55					P110				
		LN80					C90					LN80					C90				
		1451					1600					1559					1708				
		834					1830					853					1803				
		1079										1274					1424				
		451					1376					1227					1424				
		491					1376					1566					1668				
		491					1471					451					530				
		1681					131.3					530					588				
		1600					114.3					530					588				
		1376					86.9					1708					1803				
		1376					92.5					1559					1803				
		1376					85.7					1559					1803				
		491					87.7					451					530				
		491					87.7					451					530				
		491					87.7					451					530				
		491					87.7					451					530				
		491					87.7					451					530				

MPa x 145 = psi daN x 2.25 = lb daN.m x 7.38 = lb.ft mm x 0.0394 = in

GEOMETRICAL CHARACTERISTICS AND MECHANICAL PROPERTIES OF TUBING (continued)

		4.500 in		114.3 mm						
		26.10 lb/ft		38.09 daN/m						
Pipe body	1	Nominal size (OD)								
	2	Nominal weight								
	3	Wall thickness			16.0 mm					
	4	Inside diameter			82.3 mm					
	5	Steel cross-section			4942 mm ²					
	6	Capacity			5.32 l/m					
	7	Displacement			10.26 l/m					
	8	Grade	J55	L80	N80	C90	T95	P110		
	9	Collapse resistance (MPa)	91.3	132.8	132.8	149.4	157.7	182.6		
	10	Internal yield pressure (MPa)	92.9	135.1	135.1	152.0	160.5	185.8		
	11	Pipe body yield strength (1000 daN)	187.4	272.6	272.6	306.6	323.7	374.8		
			100.0							
Connection efficiency	12	API Non-Upset								
	13	API External Upset								
	14	Grant Prideco CSTCP								
	15	Grant Prideco STL								
	16	Grant Prideco TCII								
	17	Hydril CS								
	18	Hydril PH4-PH6								
	19	Vallourec & Mannesmann TDS								
	20	Vallourec & Mannesmann New VAM								
	21	Vallourec & Mannesmann VAM ACE								
	22	Vallourec & Mannesmann VAM PRO								
23	Vallourec & Mannesmann FJL									
Connection characteristics			Make-up torque (daN.m)				OD (mm)	ID (mm)	Drift API (mm)	
			J55	LN80	C90	C95	P110			
	24	API Non-Upset								
	25	API External Upset								
	26	Grant Prideco CSTCP								
	27	Grant Prideco STL								
	28	Grant Prideco TCII								
	29	Hydril CS								
	30	Hydril PH4-PH6	1756	1939	2027	2210	144.5	80.3	79.1	
	31	Vallourec & Mannesmann TDS								
	32	Vallourec & Mannesmann New VAM								
	33	Vallourec & Mannesmann VAM ACE								
34	Vallourec & Mannesmann VAM PRO									
35	Vallourec & Mannesmann FJL									

MPa x 145 = psi daN x 2.25 = lb daN.m x 7.38 = lb.ft mm x 0.0394 = in

GEOMETRICAL CHARACTERISTICS AND MECHANICAL PROPERTIES OF CASING

	1	Nominal size (OD)	1	4.500 in					114.3 mm					4.500 in					114.3 mm				
				10.50 lb/ft					15.3 daN/m					11.60 lb/ft					16.9 daN/m				
Pipe body	2	Nominal weight	2	10.50 lb/ft					15.3 daN/m					11.60 lb/ft					16.9 daN/m				
	3	Wall thickness	3	0.224 in					5.7 mm					0.250 in					6.3 mm				
	4	Inside diameter	4	4.052 in					102.9 mm					4.000 in					101.6 mm				
	5	Steel cross-section	5	3.01 in ²					1941 mm ²					3.34 in ²					2154 mm ²				
	6	Capacity	6	0.67 gal/ft					8.32 l/m					0.65 gal/ft					8.11 l/m				
	7	Displacement (1)	7	0.83 gal/ft					10.26 l/m					0.83 gal/ft					10.26 l/m				
	8	Grade	8	K55	L80	N80	C90	T95	P110	Q125	K55	L80	N80	C90	T95	P110	Q125						
Pipe body	9	Collapse resistance (MPa)	9	27.6	34.0	34.0	35.9	36.6	38.3	40.2	34.2	43.8	43.8	47.0	48.4	52.2	55.2						
	10	Internal yield pressure (MPa)	10	33.0	48.0	48.0	54.1	57.1	66.1	75.1	36.9	53.6	53.6	60.3	63.7	73.7	83.8						
	11	Pipe body yield strength (1000 daN)	11	74	107	107	120	127	147	167	82	119	119	134	141	163	186						
Tensile strength (10 ³ daN)	12	Buttress Standard	12	111	117	122	124	130	154	168	123	129	135	138	145	171	187						
	13	Buttress Special Clearance	13	111	117	122	124	130	154	168	123	129	135	138	145	171	187						
	14	API STC	14	65	81	83	85	90	107	115	76	94	96	99	104	124	134						
	15	API LTC	15	69	81	85	85	90	107	115	80	94	99	99	104	124	134						
Connection efficiency	16	Grant Prideco TCII	16																				
	17	Grant Prideco STL	17	48.5										52.8									
	18	Hydriil LX	18																				
	19	Hydriil 563	19											91.1									
	20	Hydriil 511	20	63.2										63.2									
	21	Hydriil 521	21	60.5										64.1									
	22	Vallourec & Mannesmann New VAM	22	113.7										102.5									
	23	Vallourec & Mannesmann VAM ACE	23	112.4										104.1									
	24	Vallourec & Mannesmann VAM PRO	24	100.0										100.0									
	25	Vallourec & Mannesmann VAM TOP	25																				
	26	Vallourec & Mannesmann FJL	26											45.9									
Connection characteristics	27	Buttress Standard	27	Make-up torque (daN.m)					OD (mm)	ID (mm)	Drift API (mm)	Make-up torque (daN.m)					OD (mm)	ID (mm)	Drift API (mm)				
	28	Buttress Special Clearance	28	K55	L80	C90/95	P110	Q125				K55	L80	C90/95	P110	Q125							
	29	API STC	29	198					127.0					127.0									
	30	API LTC	30						123.8					127.0									
	31	Grant Prideco TCII	31		549	549	549	549	123.3	104.4	99.7		230		549	549	549	549	124.4	103.1	98.4		
	32	Grant Prideco STL	32	149	190	190	190	190	114.3	100.4	99.7	176	230	230	230	230	114.3	99.8	98.4				
	33	Hydriil LX	33																				
	34	Hydriil 563	34										407	407	407	407	132.1	100.3	98.4				
	35	Hydriil 511	35	230	230	230	230	230	114.3	100.6	99.7	244	244	244	244	244	114.3	99.3	98.4				
	36	Hydriil 521	36	420	420	420	420	420	118.1	101.0	99.7	488	488	488	488	488	119.3	100.6	98.4				
	37	Vallourec & Mannesmann New VAM	37	461	607	706	795	892	123.5		99.7	470	628	725	813	912	123.5		98.4				
	38	Vallourec & Mannesmann VAM ACE	38	373	451	491	540	588	123.5		99.7	441	540	588	637	686	123.8		98.4				
	39	Vallourec & Mannesmann VAM PRO	39						122.9		99.7						124.0		98.4				
	40	Vallourec & Mannesmann VAM TOP	40																				
	41	Vallourec & Mannesmann FJL	41										294	324	363	403	114.3	99.5	98.4				

(1) The closed-end displacement does not account for couplings. MPa × 145 = psi daN × 2.25 = lb daN.m × 7.38 = lb.ft mm × 0.0394 = in

GEOMETRICAL CHARACTERISTICS AND MECHANICAL PROPERTIES OF CASING (continued)

		4.500 in 114.3 mm								4.500 in 114.3 mm								
		13.50 lb/ft 19.7 daN/m								15.10 lb/ft 22.0 daN/m								
Pipe body	1	Nominal size (OD)	4.500 in 114.3 mm								4.500 in 114.3 mm							
	2	Nominal weight	13.50 lb/ft 19.7 daN/m								15.10 lb/ft 22.0 daN/m							
	3	Wall thickness	0.290 in 7.4 mm								0.337 in 8.6 mm							
	4	Inside diameter	3.920 in 99.6 mm								3.826 in 97.2 mm							
	5	Steel cross-section	3.84 in ² 2475 mm ²								4.41 in ² 2844 mm ²							
	6	Capacity	0.63 gal/ft 7.79 l/m								0.60 gal/ft 7.42 l/m							
	7	Displacement (1)	0.83 gal/ft 10.26 l/m								0.83 gal/ft 10.26 l/m							
	8	Grade	K55 L80 N80 C90 T95 P110 Q125								K55 L80 N80 C90 T95 P110 Q125							
	9	Collapse resistance (MPa)	44.3 58.9 58.9 64.1 66.6 73.7 80.0								52.5 76.4 76.4 84.3 88.0 98.9 109.1							
	10	Internal yield pressure (MPa)	42.8 62.2 62.2 70.0 73.9 85.5 97.2								49.7 72.3 72.3 81.3 85.8 99.4 112.9							
	11	Pipe body yield strength (1000 daN)	94 136 136 154 162 188 213								108 157 157 176 186 216 245							
Tensile strength (10 ³ daN)	12	Buttress Standard	141	149	155	158	166	197	214	162	171	178	182	191	226	246		
	13	Buttress Special Clearance	141	142	150	150	157	187	202	142	142	150	150	157	187	202		
	14	API STC	92	114	117	120	126	150	162	110	137	140	144	152	180	195		
	15	API LTC	97	114	120	120	126	150	162	116	137	144	144	152	180	195		
Connection efficiency	16	Grant Prideco TCII																
	17	Grant Prideco STL	56.9								58.9							
	18	Hydriil LX	73.8								72.8							
	19	Hydriil 563	92.2								93.3							
	20	Hydriil 511	60.6								61.2							
	21	Hydriil 521	68.2															
	22	Vallourec & Mannesmann New VAM	109.0								103.6							
	23	Vallourec & Mannesmann VAM ACE	108.1								101.9							
	24	Vallourec & Mannesmann VAM PRO	100.0								100.0							
	25	Vallourec & Mannesmann VAM TOP																
	26	Vallourec & Mannesmann FJL	52.9								59.1							
Connection characteristics			Make-up torque (daN.m)					OD (mm)	ID (mm)	Drift API (mm)	Make-up torque (daN.m)					OD (mm)	ID (mm)	Drift API (mm)
			K55	LN80	C90/95	P110	Q125				K55	LN80	C90/95	P110	Q125			
	27	Buttress Standard					127.0		96.4					127.0		94.0		
	28	Buttress Special Clearance					123.8		96.4					123.8		94.0		
	29	API STC																
	30	API LTC		371	424	496		127.0		96.4				597	666	127.0	94.0	
	31	Grant Prideco TCII		549	549	549	549	126.0	101.1	96.4		549	549	549	549	127.9	98.7	94.0
	32	Grant Prideco STL	217	285	285	285	285	114.3	97.9	96.4	258	339	339	339	339	114.3	95.9	94.0
	33	Hydriil LX	339	400	441	475	508	116.5	97.5	96.4	407	488	529	583	630	116.8	95.1	94.0
	34	Hydriil 563	542	542	542	542		132.1	98.3	96.4	800	800	800	800		132.1	94.0	
	35	Hydriil 511	285	285	285	285	285	114.3	97.2	96.4	380	380	380	380	380	114.3	94.8	94.0
	36	Hydriil 521	569	569	569	569	569	120.9	98.6	96.4								
	37	Vallourec & Mannesmann New VAM	500	667	765	864	952	126.0		96.4	569	785	902	1029	1125	127.3	94.0	
	38	Vallourec & Mannesmann VAM ACE	491	569	618	667	735	126.0		96.4	588	735	785	834	883	127.1	94.0	
	39	Vallourec & Mannesmann VAM PRO						125.6		96.4						125.3	94.0	
	40	Vallourec & Mannesmann VAM TOP																
	41	Vallourec & Mannesmann FJL		315	343	382	422	114.3	97.6	96.4		343	373	412	451	114.3	95.4	94.0

(1) The closed-end displacement does not account for couplings. MPa × 145 = psi daN × 2.25 = lb daN.m × 7.38 = lb.ft mm × 0.0394 = in

GEOMETRICAL CHARACTERISTICS AND MECHANICAL PROPERTIES OF CASING (continued)

		5.000 in 127.0 mm								5.000 in 127.0 mm										
Pipe body	1	Nominal size (OD)	5.000 in 127.0 mm								5.000 in 127.0 mm									
	2	Nominal weight	13.00 lb/ft 19.0 daN/m								15.00 lb/ft 21.9 daN/m									
	3	Wall thickness	0.253 in 6.4 mm				0.296 in 7.5 mm													
	4	Inside diameter	4.494 in 114.1 mm				4.408 in 112.0 mm													
	5	Steel cross-section	3.77 in ² 2434 mm ²				4.37 in ² 2822 mm ²													
	6	Capacity	0.82 gal/ft 10.23 l/m				0.79 gal/ft 9.85 l/m													
	7	Displacement (1)	1.02 gal/ft 12.67 l/m				1.02 gal/ft 12.67 l/m													
	8	Grade	8	K55	L80	N80	C90	T95	P110	Q125	K55	L80	N80	C90	T95	P110	Q125			
9	Collapse resistance (MPa)	9	28.6	35.4	35.4	37.4	38.3	40.3	41.7	38.3	50.0	50.0	54.0	55.9	61.0	65.4				
10	Internal yield pressure (MPa)	10	33.6	48.8	48.8	54.9	58.0	67.2	76.3	39.3	57.1	57.1	64.3	67.9	78.6	89.3				
11	Pipe body yield strength (1000 daN)	11	92	134	134	151	159	185	210	107	156	156	175	185	214	243				
Tensile strength (10 ³ daN)	12	Buttress Standard	12	138	145	152	155	163	193	210	159	169	176	180	189	224	244			
	13	Buttress Special Clearance	13	138	145	152	155	163	193	210	159	162	171	171	179	213	230			
	14	API STC	14	83	104	106	113	118	140	152	101	127	129	138	145	172	187			
	15	API LTC	15	89	107	113	113	118	141	152	110	131	138	138	145	173	187			
Connection efficiency	16	Grant Prideco TCII	16												57.0					
	17	Grant Prideco STL	17	54.4											71.9					
	18	HydriL LX	18												90.3					
	19	HydriL 563	19	88.8											60.7					
	20	HydriL 511	20												64.4					
	21	HydriL 521	21	64.4											125.7					
	22	Vallourec & Mannesmann New VAM	22	145.7											121.1					
	23	Vallourec & Mannesmann VAM ACE	23	140.4											100.0					
	24	Vallourec & Mannesmann VAM PRO	24	100.0											102.0					
	25	Vallourec & Mannesmann VAM TOP	25												55.0					
26	Vallourec & Mannesmann FJL	26	55.1																	
Connection Characteristics	27	Buttress Standard	27	Make-up torque (daN.m)					OD (mm)	ID (mm)	Drift API (mm)	Make-up torque (daN.m)					OD (mm)	ID (mm)	Drift API (mm)	
	28	Buttress Special Clearance	28	K55	LN80	C90/95	P110	Q125				K55	LN80	C90/95	P110	Q125				
	29	API STC	29	252					141.3	111.0		309							141.3	108.8
	30	API LTC	30	273					141.3	111.0		334	422	483					141.3	108.8
	31	Grant Prideco TCII	31						141.3	111.0			502	502	502	502	137.9	109.6	108.8	
	32	Grant Prideco STL	32	203	271	271	271	271	127.0	112.3	111.0	258	325	325	325	325	127.0	110.4	108.8	
	33	HydriL LX	33						141.3	112.9	111.0	407	488	536	590	637	129.3	109.9	108.8	
	34	HydriL 563	34	610	610	610	610	610	141.3	112.9	111.0	746	746	746	746	746	141.3	110.7	108.8	
	35	HydriL 511	35						141.3	112.9	111.0	312	312	312	312	312	127.0	109.7	108.8	
	36	HydriL 521	36	556	556	556	556	556	131.7	112.9	111.0	556	556	556	556	556	133.5	110.7	108.8	
	37	Vallourec & Mannesmann New VAM	37	569	618	658	686	716	141.9		111.0	637	697	725	755	795	141.9		108.8	
	38	Vallourec & Mannesmann VAM ACE	38	491	540	588	637	686	141.3		111.0	491	540	588	637	686	141.3		108.8	
	39	Vallourec & Mannesmann VAM PRO	39						141.8		111.0						141.8		108.8	
	40	Vallourec & Mannesmann VAM TOP	40						141.8		111.0						141.8		108.8	
	41	Vallourec & Mannesmann FJL	41		245	285	324	390	127.0	112.2	111.0	588	686	785	883	980	138.9	112.5	108.8	

(1) The closed-end displacement does not account for couplings. MPa × 145 = psi daN × 2.25 = lb daN.m × 7.38 = lb.ft mm × 0.0394 = in

GEOMETRICAL CHARACTERISTICS AND MECHANICAL PROPERTIES OF CASING (continued)

			5.000 in 127.0 mm							5.000 in 127.0 mm											
			18.00 lb/ft 26.3 daN/m							21.40 lb/ft 31.2 daN/m											
Pipe body	1	Nominal size (OD)	1	5.000 in 127.0 mm							5.000 in 127.0 mm										
	2	Nominal weight	2	18.00 lb/ft 26.3 daN/m							21.40 lb/ft 31.2 daN/m										
	3	Wall thickness	3	0.362 in 9.2 mm							0.437 in 11.1 mm										
	4	Inside diameter	4	4.276 in 108.6 mm							4.126 in 104.8 mm										
	5	Steel cross-section	5	5.27 in ² 3403 mm ²							6.26 in ² 4042 mm ²										
	6	Capacity	6	0.75 gal/ft 9.26 l/m							0.69 gal/ft 8.63 l/m										
	7	Displacement (1)	7	1.02 gal/ft 12.67 l/m							1.02 gal/ft 12.67 l/m										
	8	Grade	8	K55	L80	N80	C90	T95	P110	Q125	K55	L80	N80	C90	T95	P110	Q125				
	9	Collapse resistance (MPa)	9	50.9	72.3	72.3	79.5	82.9	92.9	102.2	60.5	88.0	88.0	99.0	104.5	121.0	137.5				
	10	Internal yield pressure (MPa)	10	48.0	69.9	69.9	78.6	83.0	96.1	109.2	58.0	84.4	84.4	94.9	100.2	116.0	131.8				
	11	Pipe body yield strength (1000 daN)	11	129	188	188	211	223	258	293	153	223	223	251	265	307	348				
Tensile strength (10 ³ daN)	12	Buttress Standard	12	192	203	212	217	228	270	294	227	227	239	239	251	299	322				
	13	Buttress Special Clearance	13	162	162	171	171	179	213	230	162	162	171	171	179	213	230				
	14	API STC	14	129	162	165	176	185	219	238	160	200	204	218	229	271	294				
	15	API LTC	15	140	167	176	176	185	220	238	173	207	218	218	229	273	294				
Connection efficiency	16	Grant Prideco TCII	16																		
	17	Grant Prideco STL	17	58.2																	
	18	HydriL LX	18	70.1							79.2										
	19	HydriL 563	19	92.0							88.8										
	20	HydriL 511	20	62.8																	
	21	HydriL 521	21	73.8																	
	22	Vallourec & Mannesmann New VAM	22	104.2							87.8										
	23	Vallourec & Mannesmann VAM ACE	23	102.0							111.1										
	24	Vallourec & Mannesmann VAM PRO	24	100.0							91.0										
	25	Vallourec & Mannesmann VAM TOP	25	102.1							102.1										
	26	Vallourec & Mannesmann FJL	26	60.8							65.2										
Connection characteristics	27	Buttress Standard	27	Make-up torque (daN.m)					OD (mm)	ID (mm)	Drift API (mm)	Make-up torque (daN.m)					OD (mm)	ID (mm)	Drift API (mm)		
	28	Buttress Special Clearance	28						141.3		105.4						141.3		101.6		
	29	API STC	29						136.5		105.4						136.5		101.6		
	30	API LTC	30		538	617			141.3		105.4	665	762			141.3		101.6			
	31	Grant Prideco TCII	31		556	556	556	556	140.5	109.6	105.4	922	922	922	922	143.4	106.3	101.6			
	32	Grant Prideco STL	32	325	380	380	380	380	127.0	106.4	105.4										
	33	HydriL LX	33	515	597	644	691	739	129.7	106.6	105.4	563	651	705	759	813	130.0	102.8	101.6		
	34	HydriL 563	34	881	881	881	881	881	141.3		105.4	1885	1885	1885	1885	1885	146.1	103.5	101.6		
	35	HydriL 511	35	542	542	542	542	542	127.0	106.3	105.4										
	36	HydriL 521	36	827	827	827	827	827	136.1	107.3	105.4										
	37	Vallourec & Mannesmann New VAM	37	774	834	873	912	961	141.9		105.4	971	1079	1125	1180	1227	141.9		101.6		
	38	Vallourec & Mannesmann VAM ACE	38	637	785	883	931	1029	141.5		105.4	883	1079	1180	1274	1376	146.1		101.6		
	39	Vallourec & Mannesmann VAM PRO	39								141.8		105.4						141.8		101.6
	40	Vallourec & Mannesmann VAM TOP	40	686	785	834	931	1029	141.7		105.4	931	1125	1274	1376	1471	144.6		101.6		
	41	Vallourec & Mannesmann FJL	41		264	304	343	373	127.0	106.9	105.4		530	569	588	607	127.0	103.6	101.6		

(1) The closed-end displacement does not account for couplings. MPa × 145 = psi daN × 2.25 = lb daN.m × 7.38 = lb.ft mm × 0.0394 = in

GEOMETRICAL CHARACTERISTICS AND MECHANICAL PROPERTIES OF CASING (continued)

Pipe body	1	Nominal size (OD)	1	5.000 in					127.0 mm					5.000 in					127.0 mm				
	2	Nominal weight	2	23.20 lb/ft					33.9 daN/m					24.10 lb/ft					35.2 daN/m				
	3	Wall thickness	3	0.478 in					12.1 mm					0.500 in					12.7 mm				
	4	Inside diameter	4	4.044 in					102.7 mm					4.000 in					101.6 mm				
	5	Steel cross-section	5	6.79 in ²					4381 mm ²					7.07 in ²					4560 mm ²				
	6	Capacity	6	0.67 gal/ft					8.29 l/m					0.65 gal/ft					8.11 l/m				
	7	Displacement (1)	7	1.02 gal/ft					12.67 l/m					1.02 gal/ft					12.67 l/m				
	8	Grade	8	K55	L80	N80	C90	T95	P110	Q125	K55	L80	N80	C90	T95	P110	Q125						
	9	Collapse resistance (MPa)	9	65.6	95.4	95.4	107.3	113.3	131.1	149.0	68.3	99.3	99.3	111.7	117.9	136.5	155.1						
10	Internal yield pressure (MPa)	10	63.4	92.3	92.3	103.8	109.6	126.9	144.2	66.4	96.5	96.5	108.6	114.6	132.7	150.8							
11	Pipe body yield strength (1000 daN)	11	166	242	242	272	287	332	378	173	252	252	283	299	346	393							
Tensile strength (10 ³ daN)	12	Buttress Standard	12	227	227	239	239	251	299	322	227	227	239	239	251	299	322						
	13	Buttress Special Clearance	13	162	162	171	171	179	213	230	162	162	171	171	179	213	230						
	14	API STC	14	176	221	225	240	252	299	324	185	232	236	252	265	314	340						
	15	API LTC	15	191	228	240	240	252	300	324	200	239	252	252	265	315	340						
Connection efficiency	16	Grant Prideco TCII	16																				
	17	Grant Prideco STL	17													67.6							
	18	Hydril LX	18													79.0							
	19	Hydril 563	19													89.7							
	20	Hydril 511	20																				
	21	Hydril 521	21																				
	22	Vallourec & Mannesmann New VAM	22													81.0							
	23	Vallourec & Mannesmann VAM ACE	23													102.5							
	24	Vallourec & Mannesmann VAM PRO	24													89.0							
	25	Vallourec & Mannesmann VAM TOP	25													102.0							
	26	Vallourec & Mannesmann FJL	26													67.4							
Connection characteristics	27	Buttress Standard	27	Make-up torque (daN.m)					OD (mm)	ID (mm)	Drift API (mm)	Make-up torque (daN.m)					OD (mm)	ID (mm)	Drift API (mm)				
	28	Buttress Special Clearance	28	K55	L80	C90/95	P110	Q125				K55	L80	C90/95	P110	Q125							
	29	API STC	29																				
	30	API LTC	30																				
	31	Grant Prideco TCII	31		1139	1139	1139	1139	144.9	104.4	99.5					141.3		98.4					
	32	Grant Prideco STL	32	461	590	590	590	590	127.0	101.3	99.5	420	529	529	529	529	127.0	103.0	98.4				
	33	Hydril LX	33	583	678	739	766	847	130.3	100.7	99.5	630	725	780	841	902	130.4	99.6	98.4				
	34	Hydril 563	34	1966	1966	1966	1966	1966	146.1	101.4	99.5	2034	2034	2034	2034	2034	146.1	100.3	98.4				
	35	Hydril 511	35																				
	36	Hydril 521	36																				
	37	Vallourec & Mannesmann New VAM	37	1029	1125	1180	1227	1274	141.9		99.5	1029	1125	1180	1274	1322	141.9		98.4				
	38	Vallourec & Mannesmann VAM ACE	38	980	1274	1376	1519	1668	146.1		99.5	1079	1376	1471	1668	1763	147.5		98.4				
	39	Vallourec & Mannesmann VAM PRO	39						141.8		99.5					141.8			98.4				
	40	Vallourec & Mannesmann VAM TOP	40	1079	1322	1424	1620	1817	146.1		99.5												
	41	Vallourec & Mannesmann FJL	41		540	588	637	697	127.0	101.5	99.5		549	607	667	716	127.0	100.5	98.4				

(1) The closed-end displacement does not account for couplings. MPa × 145 = psi daN × 2.25 = lb daN.m × 7.38 = lb.ft mm × 0.0394 = in

GEOMETRICAL CHARACTERISTICS AND MECHANICAL PROPERTIES OF CASING (continued)

Pipe body	1	Nominal size (OD)	1	5.500 in					139.7 mm					5.500 in					139.7 mm				
	2	Nominal weight	2	14.00 lb/ft					20.4 daN/m					15.50 lb/ft					22.6 daN/m				
	3	Wall thickness	3	0.244 in					6.2 mm					0.275 in					7.0 mm				
	4	Inside diameter	4	5.012 in					127.3 mm					4.950 in					125.7 mm				
	5	Steel cross-section	5	4.03 in ²					2599 mm ²					4.51 in ²					2912 mm ²				
	6	Capacity	6	1.02 gal/ft					12.73 l/m					1.00 gal/ft					12.42 l/m				
	7	Displacement (1)	7	1.23 gal/ft					15.33 l/m					1.23 gal/ft					15.33 l/m				
	8	Grade	8	K55	L80	N80	C90	T95	P110	Q125	K55	L80	N80	C90	T95	P110	Q125						
	9	Collapse resistance (MPa)	9	21.5	24.9	24.9	26.6	27.3	29.2	30.4	27.9	34.4	34.4	36.3	37.1	38.8	40.6						
	10	Internal yield pressure (MPa)	10	29.4	42.8	42.8	48.2	50.9	58.9	66.9	33.2	48.3	48.3	54.3	57.3	66.4	75.4						
	11	Pipe body yield strength (1000 daN)	11	99	143	143	161	170	197	224	110	161	161	181	191	221	251						
Tensile strength (10 ⁵ daN)	12	Buttress Standard	12	145	155	161	165	173	205	224	163	173	181	185	194	230	251						
	13	Buttress Special Clearance	13	145	155	161	165	173	205	224	163	173	181	185	194	230	251						
	14	API STC	14	84	106	108	117	123	144	161	99	124	126	137	144	168	188						
	15	API LTC	15	91	113	116	119	125	149	161	106	132	136	139	146	174	188						
Connection efficiency	16	Grant Prideco TCII	16												49.3								
	17	Grant Prideco STL	17												49.3								
	18	Hydril LX	18												49.3								
	19	Hydril 563	19												88.5								
	20	Hydril 511	20												89.7								
	21	Hydril 521	21												60.4								
	22	Vallourec & Mannesmann New VAM	22												66.9								
	23	Vallourec & Mannesmann VAM ACE	23												132.4								
	24	Vallourec & Mannesmann VAM PRO	24												128.5								
	25	Vallourec & Mannesmann VAM TOP	25												100.0								
26	Vallourec & Mannesmann FJL	26												102.1									
Connection characteristics	27	Buttress Standard	27	Make-up torque (daN.m)					OD (mm)	ID (mm)	Drift API (mm)	Make-up torque (daN.m)					OD (mm)	ID (mm)	Drift API (mm)				
	28	Buttress Special Clearance	28						153.7		124.1						153.7		122.6				
	29	API STC	29	256					153.7		124.1	301					153.7		122.6				
	30	API LTC	30									324					153.7		122.6				
	31	Grant Prideco TCII	31														149.8	124.2	122.6				
	32	Grant Prideco STL	32	217	271	271	271	271	139.7	125.5	124.1	230	339	339	339	339	139.7	124.2	122.6				
	33	Hydril LX	33																				
	34	Hydril 563	34	610	610	610	610	610	153.7	126.0	124.1	705	705	705	705	705	153.7	124.5	122.6				
	35	Hydril 511	35									312	312	312	312	312	139.7	123.4	122.6				
	36	Hydril 521	36	542	542	542	542	542	143.8	125.7	124.1	624	624	624	624	624	145.1	124.5	122.6				
	37	Vallourec & Mannesmann New VAM	37	540	647	686	725	765	154.3		124.1	637	697	735	774	813	154.3		122.6				
	38	Vallourec & Mannesmann VAM ACE	38									392	491	540	588	637	153.7		122.6				
	39	Vallourec & Mannesmann VAM PRO	39														154.2		122.6				
	40	Vallourec & Mannesmann VAM TOP	40									540	686	785	883	980	150.6		122.6				
	41	Vallourec & Mannesmann FJL	41										363	412	470	519	139.7	123.8	122.6				

(1) The closed-end displacement does not account for couplings. MPa × 145 = psi daN × 2.25 = lb daN.m × 7.38 = lb.ft mm × 0.0394 = in

GEOMETRICAL CHARACTERISTICS AND MECHANICAL PROPERTIES OF CASING (continued)

Pipe body	1	Nominal size (OD)	1	5.500 in		139.7 mm		5.500 in		139.7 mm									
	2	Nominal weight	2	17.00 lb/ft		24.8 daN/m		20.00 lb/ft		29.2 daN/m									
	3	Wall thickness	3	0.304 in		7.7 mm		0.361 in		9.2 mm									
	4	Inside diameter	4	4.892 in		124.3 mm		4.778 in		121.4 mm									
	5	Steel cross-section	5	4.96 in ²		3202 mm ²		5.83 in ²		3760 mm ²									
	6	Capacity	6	0.98 gal/ft		12.13 l/m		0.93 gal/ft		11.57 l/m									
	7	Displacement (1)	7	1.23 gal/ft		15.33 l/m		1.23 gal/ft		15.33 l/m									
	8	Grade	8	K55	L80	N80	C90	T95	P110	Q125	K55	L80	N80	C90	T95	P110	Q125		
	9	Collapse resistance (MPa)	9	33.9	43.3	43.3	46.5	47.9	51.6	54.4	45.6	60.9	60.9	66.4	69.1	76.6	83.3		
	10	Internal yield pressure (MPa)	10	36.7	53.4	53.4	60.0	63.4	73.4	83.4	43.6	63.4	63.4	71.3	75.2	87.1	99.0		
	11	Pipe body yield strength (1000 daN)	11	121	177	177	199	210	243	276	143	207	207	233	246	285	324		
Tensile strength (10 ³ daN)	12	Buttress Standard	12	179	190	198	203	213	253	276	210	224	233	238	251	297	324		
	13	Buttress Special Clearance	13	179	179	189	189	198	236	255	179	179	189	189	198	236	255		
	14	API STC	14	112	141	144	155	164	191	214	138	174	177	191	202	235	263		
	15	API LTC	15	121	150	155	158	166	198	214	149	185	190	195	205	244	263		
	Connection efficiency	16	Grant Prideco TCII	16															
17		Grant Prideco STL	17			52.9						59.0							
18		Hydril LX	18			71.9						71.0							
19		Hydril 563	19			90.6						92.0							
20		Hydril 511	20			60.9						62.4							
21		Hydril 521	21			69.6						73.8							
22		Vallourec & Mannesmann New VAM	22			120.5						102.6							
23		Vallourec & Mannesmann VAM ACE	23			116.9						115.7							
24		Vallourec & Mannesmann VAM PRO	24			100.0						100.0							
25		Vallourec & Mannesmann VAM TOP	25			102.1						102.1							
26		Vallourec & Mannesmann FJL	26			55.1						58.7							
Connection characteristics			Make-up torque (daN.m)					OD (mm)	ID (mm)	Drift API (mm)	Make-up torque (daN.m)					OD (mm)	ID (mm)	Drift API (mm)	
			K55	LN80	C90/95	P110	Q125				K55	LN80	C90/95	P110	Q125				
	27	Buttress Standard	27						153.7		121.1						153.7		118.2
	28	Buttress Special Clearance	28						149.2		121.1						149.2		118.2
	29	API STC	29	342					153.7		121.1								
	30	API LTC	30	369	467	537	626		153.7		121.1		575	660	771		153.7		118.2
	31	Grant Prideco TCII	31		590	590	590	590	151.0	122.3	121.1		630	630	630	630	153.3	122.3	118.2
	32	Grant Prideco STL	32	271	380	380	380	380	139.7	122.4	121.1	298	447	447	447	447	139.7	119.3	118.2
	33	Hydril LX	33	475	576	644	705	766	142.2	122.2	121.1	583	685	746	807	868	142.4	119.3	118.2
	34	Hydril 563	34	786	786	786	786	786	153.7	123.0	121.1	895	895	895	895	895	153.7		118.2
	35	Hydril 511	35	339	339	339	339	339	139.7	122.0	121.1	529	529	529	529	529	139.7	119.1	118.2
	36	Hydril 521	36	705	705	705	705	705	146.3	123.0	121.1	854	854	854	854	854	148.6	120.1	118.2
	37	Vallourec & Mannesmann New VAM	37	686	746	785	824	864	154.3		121.1	804	883	922	971	1029	154.3		118.2
	38	Vallourec & Mannesmann VAM ACE	38	540	686	735	785	834	153.7		121.1	735	883	980	1029	1125	156.2		118.2
	39	Vallourec & Mannesmann VAM PRO	39						154.2		121.1						154.2		118.2
	40	Vallourec & Mannesmann VAM TOP	40	588	735	834	931	1029	151.8		121.1	735	883	980	1029	1125	154.2		118.2
	41	Vallourec & Mannesmann FJL	41		382	431	480	540	139.7	122.5	121.1	480	549	607	677	747	139.7	119.6	118.2

(1) The closed-end displacement does not account for couplings. MPa x 145 = psi daN x 2.25 = lb daN.m x 7.38 = lb.ft mm x 0.0394 = in

GEOMETRICAL CHARACTERISTICS AND MECHANICAL PROPERTIES OF CASING (continued)

	Pipe body	1	Nominal size (OD)		1	5.500 in		139.7 mm		5.500 in		139.7 mm								
			2	23.00 lb/ft		33.6 daN/m	2	26.00 lb/ft	37.9 daN/m											
	Pipe body	3	Wall thickness	3	0.415 in	10.5 mm	0.476 in	12.1 mm												
		4	Inside diameter	4	4.670 in	118.6 mm	4.548 in	115.5 mm												
		5	Steel cross-section	5	6.63 in ²	4277 mm ²	7.51 in ²	4847 mm ²												
		6	Capacity	6	0.89 gal/ft	11.05 l/m	0.84 gal/ft	10.48 l/m												
		7	Displacement (1)	7	1.23 gal/ft	15.33 l/m	1.23 gal/ft	15.33 l/m												
		8	Grade	8	K55 L80 N80 C90 T95 P110 Q125	K55 L80 N80 C90 T95 P110 Q125	K55 L80 N80 C90 T95 P110 Q125	K55 L80 N80 C90 T95 P110 Q125												
		9	Collapse resistance (MPa)	9	52.9 77.0 77.0 85.3 89.2 100.2 110.7	60.0 87.2 87.2 98.1 103.6 119.9 136.3														
	10	Internal yield pressure (MPa)	10	50.1 72.8 72.8 81.9 86.5 100.1 113.8	57.4 83.5 83.5 94.0 99.2 114.9 130.5															
	11	Pipe body yield strength (1000 daN)	11	162 236 236 265 280 324 369	184 267 267 301 317 368 418															
	Tensile strength (10 ³ daN)	12	Buttress Standard	12	239 245 258 258 271 322 348	245 245 258 258 271 322 348														
		13	Buttress Special Clearance	13	179 179 189 189 198 236 255	179 179 189 189 198 236 255														
		14	API STC	14	162 204 208 224 237 276 309	188 237 241 261 275 321 359														
		15	API LTC	15	175 217 223 229 240 286 309	203 253 260 266 279 333 359														
	Connection efficiency	16	Grant Prideco TCII	16																
		17	Grant Prideco STL	17		62.9						67.0								
		18	Hydril LX	18		77.7						76.3								
		19	Hydril 563	19		93.0						89.7								
		20	Hydril 511	20																
		21	Hydril 521	21		76.5														
		22	Vallourec & Mannesmann New VAM	22		90.2						79.6								
		23	Vallourec & Mannesmann VAM ACE	23		101.7						102.0								
		24	Vallourec & Mannesmann VAM PRO	24		92.0						89.0								
		25	Vallourec & Mannesmann VAM TOP	25		101.9						101.9								
		26	Vallourec & Mannesmann FJL	26		63.7						67.0								
	Connection characteristics	27	Buttress Standard	27	Make-up torque (daN.m)					OD (mm)	ID (mm)	Drift API (mm)	Make-up torque (daN.m)					OD (mm)	ID (mm)	Drift API (mm)
		28	Buttress Special Clearance	28	K55	L80	C90/95	P110	Q125				K55	L80	C90/95	P110	Q125			
		29	API STC	29						153.7					153.7			112.3		
		30	API LTC	30						149.2					149.2			112.3		
		31	Grant Prideco TCII	31		675	776	906	1013	153.7					153.7			115.4		
		32	Grant Prideco STL	32		1017	1017	1017	1017	155.4	119.9				155.4	119.9		115.4		
		33	Hydril LX	33	353	569	569	569	569	139.7	116.8				139.7	116.8		115.4		
		34	Hydril 563	34	590	698	766	827	895	142.7	116.6				142.7	116.6		115.4		
		35	Hydril 511	35	1044	1044	1044	1044	1044	153.7					153.7			115.4		
		36	Hydril 521	36						153.7					153.7			115.4		
		37	Vallourec & Mannesmann New VAM	37	990	990	990	990	990	150.8	117.3				150.8	117.3		115.4		
		38	Vallourec & Mannesmann VAM ACE	38	961	1079	1125	1180	1274	154.3					154.3			115.4		
		39	Vallourec & Mannesmann VAM PRO	39	883	1079	1180	1322	1424	156.2					156.2			115.4		
		40	Vallourec & Mannesmann VAM TOP	40						154.2					154.2			115.4		
		41	Vallourec & Mannesmann FJL	41	931	1125	1227	1424	1519	156.4					156.4			115.4		
					579	598	658	716	139.7	116.9				139.7	116.9		115.4			

(1) The closed-end displacement does not account for couplings. MPa x 145 = psi daN x 2.25 = lb daN.m x 7.38 = lb.ft mm x 0.0394 = in

GEOMETRICAL CHARACTERISTICS AND MECHANICAL PROPERTIES OF CASING (continued)

Pipe body	1	Nominal size (OD)	1	5.500 in					139.7 mm					6.625 in					168.3 mm				
	2	Nominal weight	2	26.80 lb/ft					39.1 daN/m					20.00 lb/ft					29.2 daN/m				
	3	Wall thickness	3	0.500 in					12.7 mm					0.288 in					7.3 mm				
	4	Inside diameter	4	4.500 in					114.3 mm					6.049 in					153.6 mm				
	5	Steel cross-section	5	7.85 in ²					5067 mm ²					5.73 in ²					3699 mm ²				
	6	Capacity	6	0.83 gal/ft					10.26 l/m					1.49 gal/ft					18.54 l/m				
	7	Displacement (1)	7	1.23 gal/ft					15.33 l/m					1.79 gal/ft					22.24 l/m				
	8	Grade	8	K55	L80	N80	C90	T95	P110	Q125	K55	L80	N80	C90	T95	P110	Q125						
	9	Collapse resistance (MPa)	9	62.7	91.2	91.2	102.6	108.3	125.4	142.5	20.5	24.0	24.0	25.5	26.2	27.8	28.7						
	10	Internal yield pressure (MPa)	10	60.3	87.8	87.8	98.7	104.2	120.7	137.1	28.8	42.0	42.0	47.2	49.8	57.7	65.6						
	11	Pipe body yield strength (1000 daN)	11	192	279	279	314	332	384	437	140	204	204	230	242	281	319						
Tensile strength (10 ³ daN)	12	Buttress Standard	12	245	245	258	258	271	322	348	202	217	226	233	245	289	316						
	13	Buttress Special Clearance	13	179	179	189	189	198	236	255	202	217	226	231	243	289	312						
	14	API STC	14	198	250	255	275	290	339	379	119	151	154	167	176	205	230						
	15	API LTC	15	214	267	274	281	295	351	379	129	164	167	180	189	222	243						
	16	Grant Prideco TCII	16																				
Connection efficiency	17	Grant Prideco STL	17	63.4					57.0														
	18	Hydril LX	18	78.7																			
	19	Hydril 563	19	90.2					88.6														
	20	Hydril 511	20																				
	21	Hydril 521	21											65.5									
	22	Vallourec & Mannesmann New VAM	22											168.6									
	23	Vallourec & Mannesmann VAM ACE	23	102.0					164.1														
	24	Vallourec & Mannesmann VAM PRO	24											100.0									
	25	Vallourec & Mannesmann VAM TOP	25											101.9									
	26	Vallourec & Mannesmann FJL	26	65.1																			
	Connection characteristics	27	Buttress Standard	27	Make-up torque (daN.m)					OD (mm)	ID (mm)	Drift API (mm)	Make-up torque (daN.m)					OD (mm)	ID (mm)	Drift API (mm)			
28		Buttress Special Clearance	28	K55	L80	C90/95	P110	Q125	K55				L80	C90/95	P110	Q125							
29		API STC	29						153.7									111.1					
30		API LTC	30						149.2									111.1					
31		Grant Prideco TCII	31		1356	1356	1356	1356	158.7	116.1	111.1		644	644	644	644	178.8	152.1	150.5				
32		Grant Prideco STL	32	515	651	651	651	651	139.7	113.5	111.1	325	420	420	420	420	168.3	152.1	150.5				
33		Hydril LX	33	780	902	976	1051	1119	143.1	112.3	111.1												
34		Hydril 563	34	1627	1627	1627	1627	1627	155.6	113.0	111.1	800	800	800	800	800	187.7	152.4	150.5				
35		Hydril 511	35																				
36		Hydril 521	36									746	746	746	746	746	173.2	152.4	150.5				
37		Vallourec & Mannesmann New VAM	37									765	864	912	971	1029	188.3		150.5				
38		Vallourec & Mannesmann VAM ACE	38	1125	1424	1566	1715	1864	159.5		111.1	540	686	735	785	834	187.7		150.5				
39		Vallourec & Mannesmann VAM PRO	39														188.2		150.5				
40		Vallourec & Mannesmann VAM TOP	40									637	834	931	1079	1180	179.9		150.5				
41		Vallourec & Mannesmann FJL	41						139.7	111.5	111.1												

(1) The closed-end displacement does not account for couplings. MPa × 145 = psi daN × 2.25 = lb daN.m × 7.38 = lb.ft mm × 0.0394 = in

GEOMETRICAL CHARACTERISTICS AND MECHANICAL PROPERTIES OF CASING (continued)

Pipe body	1	Nominal size (OD)	1	6.625 in					168.3 mm					6.625 in					168.3 mm				
	2	Nominal weight	2	23.20 lb/ft					33.9 daN/m					24.00 lb/ft					35.0 daN/m				
	3	Wall thickness	3	0.330 in					8.4 mm					0.352 in					8.9 mm				
	4	Inside diameter	4	5.965 in					151.5 mm					5.921 in					150.4 mm				
	5	Steel cross-section	5	6.53 in ²					4210 mm ²					6.94 in ²					4475 mm ²				
	6	Capacity	6	1.45 gal/ft					18.03 l/m					1.43 gal/ft					17.76 l/m				
	7	Displacement (1)	7	1.79 gal/ft					22.24 l/m					1.79 gal/ft					22.24 l/m				
	8	Grade	8	K55	L80	N80	C90	T95	P110	Q125	K55	L80	N80	C90	T95	P110	Q125						
	9	Collapse resistance (MPa)	9	27.7	34.1	34.1	35.9	36.7	38.4	40.2	31.4	39.7	39.7	42.3	43.5	46.4	48.4						
	10	Internal yield pressure (MPa)	10	33.1	48.1	48.1	54.1	57.1	66.1	75.1	35.3	51.3	51.3	57.7	60.9	70.5	80.1						
	11	Pipe body yield strength (1000 daN)	11	160	232	232	261	276	319	363	170	247	247	278	293	339	386						
Tensile strength (10 ³ -daN)	12	Buttress Standard	12	229	248	258	265	278	329	360	244	263	274	281	296	350	383						
	13	Buttress Special Clearance	13	220	220	231	231	243	289	312	220	220	231	231	243	289	312						
	14	API STC	14	141	179	182	198	208	243	272	152	194	197	214	225	263	295						
	15	API LTC	15	153	194	198	214	224	264	289	166	210	214	231	243	285	312						
	16	Grant Prideco TCII	16																				
17	Grant Prideco STL	17													59.8								
18	Hydril LX	18													66.6								
19	Hydril 563	19													90.6								
20	Hydril 511	20													63.3								
21	Hydril 521	21													71.0								
22	Vallourec & Mannesmann New VAM	22													139.4								
23	Vallourec & Mannesmann VAM ACE	23													135.6								
24	Vallourec & Mannesmann VAM PRO	24													100.0								
25	Vallourec & Mannesmann VAM TOP	25													102.1								
26	Vallourec & Mannesmann FJL	26													57.6								
Connection efficiency	16	Grant Prideco TCII	16																				
	17	Grant Prideco STL	17													59.8							
	18	Hydril LX	18													66.6							
	19	Hydril 563	19													90.6							
	20	Hydril 511	20													63.3							
	21	Hydril 521	21													71.0							
	22	Vallourec & Mannesmann New VAM	22													139.4							
	23	Vallourec & Mannesmann VAM ACE	23													135.6							
	24	Vallourec & Mannesmann VAM PRO	24													100.0							
	25	Vallourec & Mannesmann VAM TOP	25													102.1							
	26	Vallourec & Mannesmann FJL	26													57.6							
	Connection characteristics	27	Buttress Standard	27	Make-up torque (daN.m)					OD (mm)	ID (mm)	Drift API (mm)	Make-up torque (daN.m)					OD (mm)	ID (mm)	Drift API (mm)			
28		Buttress Special Clearance	28	K55	L80	C90/95	P110	Q125	187.7		148.3	K55	L80	C90/95	P110	Q125	187.7		147.2				
29		API STC	29					177.8		148.3	464					177.8		147.2					
30		API LTC	30								504	647	744	869		187.7		147.2					
31		Grant Prideco TCII	31		1064	1064	1064	1064	180.6	150.0	148.3	1139	1139	1139	1139	181.6	148.3	147.2					
32		Grant Prideco STL	32								420	529	529	529	529	168.3	149.3	147.2					
33		Hydril LX	33	732	922	1037	1152	1274	171.1	149.6	148.3	800	990	1098	1200	1308	171.2	148.4	147.2				
34		Hydril 563	34								1017	1017	1017	1017	1017	187.7	149.1	147.2					
35		Hydril 511	35								691	691	691	691	691	168.3	148.1	147.2					
36		Hydril 521	36								936	936	936	936	936	175.9	149.1	147.2					
37		Vallourec & Mannesmann New VAM	37	843	941	980	1079	1125	188.3		148.3	941	1079	1125	1180	1274	188.3		147.2				
38		Vallourec & Mannesmann VAM ACE	38								785	980	1079	1125	1227	187.7		147.2					
39		Vallourec & Mannesmann VAM PRO	39						188.2		148.3					188.2		147.2					
40		Vallourec & Mannesmann VAM TOP	40	686	883	980	1125	1227	181.7		148.3	735	931	1029	1180	1274	182.7		147.2				
41		Vallourec & Mannesmann FJL	41		637	736	834	931	168.3	149.8	148.3		658	755	853	952	168.3	148.8	147.2				

(1) The closed-end displacement does not account for couplings. MPa × 145 = psi daN × 2.25 = lb daN.m × 7.38 = lb.ft mm × 0.0394 = in

GEOMETRICAL CHARACTERISTICS AND MECHANICAL PROPERTIES OF CASING (continued)

		6.625 in 168.3 mm								6.625 in 168.3 mm								
		28.00 lb/ft 40.9 daN/m								32.00 lb/ft 46.7 daN/m								
Pipe body	1	Nominal size (OD)	6.625 in 168.3 mm								6.625 in 168.3 mm							
	2	Nominal weight	28.00 lb/ft 40.9 daN/m								32.00 lb/ft 46.7 daN/m							
	3	Wall thickness	0.417 in 10.6 mm								0.475 in 12.1 mm							
	4	Inside diameter	5.791 in 147.1 mm								5.675 in 144.1 mm							
	5	Steel cross-section	8.13 in ² 5247 mm ²								9.18 in ² 5921 mm ²							
	6	Capacity	1.37 gal/ft 16.99 l/m								1.31 gal/ft 16.32 l/m							
	7	Displacement (1)	1.79 gal/ft 22.24 l/m								1.79 gal/ft 22.24 l/m							
	8	Grade	K55	L80	N80	C90	T95	P110	Q125	K55	L80	N80	C90	T95	P110	Q125		
Tensile strength (10 ³ daN)	9	Collapse resistance (MPa)	42.6	56.3	56.3	61.2	63.6	70.1	75.8	50.5	71.2	71.2	78.1	81.5	91.2	100.2		
	10	Internal yield pressure (MPa)	41.8	60.8	60.8	68.4	72.1	83.5	94.9	47.6	69.2	69.2	77.9	82.2	95.2	108.1		
	11	Pipe body yield strength (1000 daN)	199	289	289	326	344	398	452	225	327	327	367	388	449	510		
Tensile strength (10 ³ daN)	12	Buttress Standard	286	308	321	330	347	410	449	323	348	362	372	391	463	506		
	13	Buttress Special Clearance	220	220	231	231	243	289	312	220	220	231	231	243	289	312		
	14	API STC	185	236	240	261	275	321	359	215	273	278	301	318	371	415		
	15	API LTC	202	256	261	282	296	347	380	233	296	301	326	342	402	440		
Connection efficiency	16	Grant Prideco TCII																
	17	Grant Prideco STL	66.9								68.1							
	18	Hydril LX	77.9								79.3							
	19	Hydril 563	92.0								92.9							
	20	Hydril 511	59.9															
	21	Hydril 521	74.7								77.3							
	22	Vallourec & Mannesmann New VAM	118.9								105.4							
	23	Vallourec & Mannesmann VAM ACE	115.7								102.5							
	24	Vallourec & Mannesmann VAM PRO	100.0								100.0							
	25	Vallourec & Mannesmann VAM TOP	101.9															
26	Vallourec & Mannesmann FJL	63.8								65.8								
Connection characteristics	27	Buttress Standard	Make-up torque (daN.m)					OD (mm)	ID (mm)	Drift API (mm)	Make-up torque (daN.m)					OD (mm)	ID (mm)	Drift API (mm)
			K55	LN80	C90/95	P110	Q125				K55	LN80	C90/95	P110	Q125			
	28	Buttress Special Clearance						187.7		143.9						187.7		141.0
	29	API STC						177.8		143.9						177.8		141.0
	30	API LTC						187.7		143.9						187.7		141.0
	31	Grant Prideco TCII		788	907	1059		187.7		143.9		911	1049	1226	1371	187.7		141.0
	32	Grant Prideco STL		1254	1254	1254	1254	184.3	148.3	143.9		1552	1552	1552	1552	186.6	145.7	141.0
	33	Hydril LX	563	705	705	705	705	168.3	145.1	143.9	637	800	800	800	800	168.3	142.5	141.0
	34	Hydril 563	793	949	1051	1146	1220	171.5	145.1	143.9	949	1105	1207	1329	1437	171.8	142.1	141.0
	35	Hydril 511	1166	1166	1166	1166	1166	187.7		143.9	1342	1342	1342	1342	1342	187.7		141.0
	36	Hydril 521	895	895	895	895	895	168.3	144.8	143.9								
	37	Vallourec & Mannesmann New VAM	1125	1125	1125	1125	1125	178.5	145.8	143.9	1302	1302	1302	1302	1302	180.8	142.9	141.0
	38	Vallourec & Mannesmann VAM ACE	1180	1322	1424	1519	1566	188.3		143.9	1227	1424	1519	1566	1668	188.3		141.0
	39	Vallourec & Mannesmann VAM PRO	1079	1274	1376	1471	1668	187.7		143.9	1376	1566	1763	1966	2156	187.7		141.0
	40	Vallourec & Mannesmann VAM TOP						188.2		143.9						188.2		141.0
	41	Vallourec & Mannesmann FJL	1079	1274	1376	1519	1668	185.3		143.9								
				706	803	902	980	168.3	145.6	143.9		755	853	952	1030	168.3	143.0	141.0

(1) The closed-end displacement does not account for couplings. MPa × 145 = psi daN × 2.25 = lb daN.m × 7.38 = lb.ft mm × 0.0394 = in

GEOMETRICAL CHARACTERISTICS AND MECHANICAL PROPERTIES OF CASING (continued)

			6.625 in						7.000 in												
			168.3 mm						177.8 mm												
Pipe body	1	Nominal size (OD)	1	6.625 in						7.000 in											
	2	Nominal weight	2	35.00 lb/ft						20.00 lb/ft											
	3	Wall thickness	3	0.525 in						0.272 in											
	4	Inside diameter	4	5.575 in						6.456 in											
	5	Steel cross-section	5	10.06 in ²						5.75 in ²											
	6	Capacity	6	1.27 gal/ft						1.70 gal/ft											
	7	Displacement (1)	7	1.79 gal/ft						2.00 gal/ft											
	8	Grade	8	K55	L80	N80	C90	T95	P110	Q125	K55	L80	N80	C90	T95	P110	Q125				
	9	Collapse resistance (MPa)	9	55.3	80.5	80.5	90.6	95.6	109.4	121.3	15.7	18.9	18.9	19.7	20.0	20.5	20.6				
	10	Internal yield pressure (MPa)	10	52.6	76.5	76.5	86.1	90.8	105.2	119.5	25.8	37.5	37.5	42.2	44.5	51.6	58.6				
	11	Pipe body yield strength (1000 daN)	11	246	358	358	403	425	492	559	141	205	205	230	243	281	320				
Tensile strength (10 ³ daN)	12	Buttress Standard	12	354	382	397	408	429	507	555	200	217	226	233	245	289	316				
	13	Buttress Special Clearance	13	220	220	231	231	243	289	312	200	217	226	233	245	289	316				
	14	API STC	14	239	305	310	336	354	413	463	113	145	147	160	168	196	220				
	15	API LTC	15	260	330	336	363	381	448	490	125	159	162	175	185	216	240				
	16	Grant Prideco TCII	16							55.7											
Connection efficiency	17	Grant Prideco STL	17							55.7											
	18	HydriL LX	18	80.6																	
	19	HydriL 563	19							88.0											
	20	HydriL 511	20																		
	21	HydriL 521	21							63.1											
	22	Vallourec & Mannesmann New VAM	22	96.1																	
	23	Vallourec & Mannesmann VAM ACE	23	102.0																	
	24	Vallourec & Mannesmann VAM PRO	24	100.0						100.0											
	25	Vallourec & Mannesmann VAM TOP	25																		
	26	Vallourec & Mannesmann FJL	26	67.4																	
	Connection characteristics	27	Buttress Standard	27	Make-up torque (daN.m)					OD (mm)	ID (mm)	Drift API (mm)	Make-up torque (daN.m)					OD (mm)	ID (mm)	Drift API (mm)	
28		Buttress Special Clearance	28	K55	L80	C90/95	P110	Q125				K55	L80	C90/95	P110	Q125					
29		API STC	29						187.7		138.4								194.5		160.8
30		API LTC	30						177.8		138.4	344							187.3		160.8
31		Grant Prideco TCII	31		1817	1817	1817	1817	188.5	143.5	138.4								194.5		160.8
32		Grant Prideco STL	32									325	407	407	407	407	177.8	162.4			160.8
33		HydriL LX	33	1024	1220	1342	1451	1559	172.0	139.6	138.4										
34		HydriL 563	34									759	759	759	759	759	194.5	162.7			160.8
35		HydriL 511	35																		
36		HydriL 521	36									705	705	705	705	705	181.6	162.1			160.8
37		Vallourec & Mannesmann New VAM	37	1322	1471	1566	1668	1763	188.3		138.4										
38		Vallourec & Mannesmann VAM ACE	38	1566	1864	2061	2156	2156	189.6		138.4										
39		Vallourec & Mannesmann VAM PRO	39						188.2		138.4								195.0		160.8
40		Vallourec & Mannesmann VAM TOP	40																		
41		Vallourec & Mannesmann FJL	41		804	902	980	1079	168.3	140.4	138.4										

(1) The closed-end displacement does not account for couplings. MPa × 145 = psi daN × 2.25 = lb daN.m × 7.38 = lb.ft mm × 0.0394 = in

GEOMETRICAL CHARACTERISTICS AND MECHANICAL PROPERTIES OF CASING (continued)

Pipe body	1	Nominal size (OD)	1	7.000 in					177.8 mm					7.000 in					177.8 mm								
	2	Nominal weight	2	23.00 lb/ft					33.6 daN/m					26.00 lb/ft					37.9 daN/m								
	3	Wall thickness	3	0.317 in					8.1 mm					0.362 in					9.2 mm								
	4	Inside diameter	4	6.366 in					161.7 mm					6.276 in					159.4 mm								
	5	Steel cross-section	5	6.66 in ²					4294 mm ²					7.55 in ²					4870 mm ²								
	6	Capacity	6	1.65 gal/ft					20.53 l/m					1.61 gal/ft					19.96 l/m								
	7	Displacement (1)	7	2.00 gal/ft					24.83 l/m					2.00 gal/ft					24.83 l/m								
	8	Grade	8	K55	L80	N80	C90	T95	P110	Q125	K55	L80	N80	C90	T95	P110	Q125										
	9	Collapse resistance (MPa)	9	22.5	26.4	26.4	27.8	28.6	30.6	32.0	29.8	37.3	37.3	39.6	40.6	43.0	44.5										
	10	Internal yield pressure (MPa)	10	30.1	43.7	43.7	49.2	51.9	60.1	68.3	34.3	49.9	49.9	56.2	59.3	68.6	78.0										
	11	Pipe body yield strength (1000 daN)	11	163	237	237	266	281	326	370	185	269	269	302	319	369	420										
Tensile strength (10 ³ daN)	12	Buttress Standard	12	232	251	261	269	283	335	366	263	285	297	305	321	380	415										
	13	Buttress Special Clearance	13	232	237	250	250	262	312	337	237	237	250	250	262	312	337										
	14	API STC	14	138	176	179	194	205	239	267	162	207	210	228	240	281	314										
	15	API LTC	15	152	193	197	213	225	262	291	178	227	231	250	264	308	342										
Connection efficiency	16	Grant Prideco TCII	16																								
	17	Grant Prideco STL	17												59.2												
	18	Hydril LX	18												74.2												
	19	Hydril 563	19												90.9												
	20	Hydril 511	20												60.9												
	21	Hydril 521	21												71.2												
	22	Vallourec & Mannesmann New VAM	22												120.1												
	23	Vallourec & Mannesmann VAM ACE	23												117.3												
	24	Vallourec & Mannesmann VAM PRO	24												100.0												
	25	Vallourec & Mannesmann VAM TOP	25												101.9												
	26	Vallourec & Mannesmann FJL	26												56.9												
Connection characteristics			Make-up torque (daN.m)					OD (mm)	ID (mm)	Drift API (mm)	Make-up torque (daN.m)					OD (mm)	ID (mm)	Drift API (mm)									
			K55	LN80	C90/95	P110	Q125				K55	LN80	C90/95	P110	Q125												
			27	Buttress Standard	27									194.5					158.5						194.5		156.2
			28	Buttress Special Clearance	28									187.3					158.5						187.3		156.2
			29	API STC	29	419								194.5					158.5	494					194.5		156.2
			30	API LTC	30	462	595				685			194.5					158.5	544	698	804	940		194.4		156.2
			31	Grant Prideco TCII	31		915				915	915	915	189.2	160.2				158.5		1193	1193	1193	1193	191.1	158.2	156.2
			32	Grant Prideco STL	32	393	502				502	502	502	177.8	160.4				158.5	508	651	651	651	651	177.8	157.8	156.2
			33	Hydril LX	33	820	942				1051	1159	1281	180.6	159.7				158.5	868	1058	1166	1302	1410	180.8	157.4	156.2
			34	Hydril 563	34	908	908				908	908	908	194.5	160.4				158.5	1058	1058	1058	1058	1058	194.5	158.1	156.2
			35	Hydril 511	35	515	515				515	515	515	177.8	159.7				158.5	813	813	813	813	813	177.8	157.1	156.2
			36	Hydril 521	36	841	841				841	841	841	183.5	159.8				158.5	976	976	976	976	976	185.4	157.5	156.2
			37	Vallourec & Mannesmann New VAM	37	843	952				1029	1079	1125	195.1					158.5	980	1125	1180	1274	1376	195.1		156.2
			38	Vallourec & Mannesmann VAM ACE	38	637	785				834	883	980	194.5					158.5	883	1079	1180	1274	1376	194.5		156.2
			39	Vallourec & Mannesmann VAM PRO	39									195.0					158.5						195.0		156.2
			40	Vallourec & Mannesmann VAM TOP	40	834	1029				1125	1274	1376	190.2					158.5	931	1125	1227	1376	1471	192.2		156.2
			41	Vallourec & Mannesmann FJL	41		795				912	1030	1128	177.8	160.0				158.5		824	941	1079	1177	177.8	157.8	156.2

(1) The closed-end displacement does not account for couplings. MPa × 145 = psi daN × 2.25 = lb daN.m × 7.38 = lb.ft mm × 0.0394 = in

GEOMETRICAL CHARACTERISTICS AND MECHANICAL PROPERTIES OF CASING (continued)

			7.000 in 177.8 mm							7.000 in 177.8 mm								
			29.00 lb/ft 42.3 daN/m							32.00 lb/ft 46.7 daN/m								
Pipe body	1	Nominal size (OD)	7.000 in 177.8 mm							7.000 in 177.8 mm								
	2	Nominal weight	29.00 lb/ft 42.3 daN/m							32.00 lb/ft 46.7 daN/m								
	3	Wall thickness	0.408 in 10.4 mm							0.453 in 11.5 mm								
	4	Inside diameter	6.184 in 157.1 mm							6.094 in 154.8 mm								
	5	Steel cross-section	8.45 in ² 5451 mm ²							9.32 in ² 6011 mm ²								
	6	Capacity	1.56 gal/ft 19.38 l/m							1.52 gal/ft 18.82 l/m								
	7	Displacement (1)	2.00 gal/ft 24.83 l/m							2.00 gal/ft 24.83 l/m								
	8	Grade	K55	L80	N80	C90	T95	P110	Q125	K55	L80	N80	C90	T95	P110	Q125		
	9	Collapse resistance (MPa)	37.3	48.4	48.4	52.3	54.0	58.8	62.8	44.6	59.3	59.3	64.6	67.2	74.3	80.7		
	10	Internal yield pressure (MPa)	38.7	56.3	56.3	63.3	66.8	77.4	87.9	42.9	62.5	62.5	70.3	74.2	85.9	97.6		
	11	Pipe body yield strength (1000 daN)	207	301	301	338	357	413	470	228	332	332	373	394	456	518		
Tensile strength (10 ³ daN)	12	Buttress Standard	295	319	332	342	359	425	465	325	352	366	377	396	468	513		
	13	Buttress Special Clearance	237	237	250	250	262	312	337	237	237	250	250	262	312	337		
	14	API STC	186	238	242	262	277	323	362	209	268	272	295	311	363	407		
	15	API LTC	205	261	266	288	304	354	394	231	294	299	324	342	399	443		
Connection efficiency	16	Grant Prideco TCII																
	17	Grant Prideco STL	63.9							67.0								
	18	Hydril LX	76.5							79.5								
	19	Hydril 563	91.8							92.6								
	20	Hydril 511	60.6															
	21	Hydril 521	73.9							76.1								
	22	Vallourec & Mannesmann New VAM	107.3							97.3								
	23	Vallourec & Mannesmann VAM ACE	104.8							128.1								
	24	Vallourec & Mannesmann VAM PRO	100.0							100.0								
	25	Vallourec & Mannesmann VAM TOP	102.1							102.1								
	26	Vallourec & Mannesmann FJL	61.5							65.1								
Connection characteristics			Make-up torque (daN.m)					OD (mm)	ID (mm)	Drift API (mm)	Make-up torque (daN.m)					OD (mm)	ID (mm)	Drift API (mm)
			K55	LN80	C90/95	P110	Q125				K55	LN80	C90/95	P110	Q125			
	27	Buttress Standard					194.5		153.9					194.5		151.6		
	28	Buttress Special Clearance					187.3		153.9					187.3		151.6		
	29	API STC																
	30	API LTC		803	926	1081	194.4		153.9		904	1041	1216	194.5		151.6		
	31	Grant Prideco TCII		1281	1281	1281	1281	193.0	158.2	153.9		1519	1519	1519	194.9	156.2	151.6	
	32	Grant Prideco STL	569	732	732	732	732	177.8	157.2	153.9	637	813	813	813	813	177.8	153.1	151.6
	33	Hydril LX	786	963	1064	1173	1295	181.1	156.5	153.9	969	1146	1241	1349	1458	181.7	153.3	151.6
	34	Hydril 563	1139	1139	1139	1139	1139	194.5		153.9	1288	1288	1288	1288	1288	194.5		151.6
	35	Hydril 511	908	908	908	908	908	177.8	154.8	153.9								
	36	Hydril 521	1125	1125	1125	1125	1125	187.3	155.2	153.9	1261	1261	1261	1261	1261	189.2	153.7	151.6
	37	Vallourec & Mannesmann New VAM	1125	1274	1376	1471	1566	195.1		153.9	1227	1376	1471	1566	1668	195.1		151.6
	38	Vallourec & Mannesmann VAM ACE	1079	1274	1376	1566	1668	194.5		153.9	1274	1519	1668	1864	1959	200.9		151.6
	39	Vallourec & Mannesmann VAM PRO						195.0		153.9						195.0		151.6
	40	Vallourec & Mannesmann VAM TOP	1079	1274	1376	1566	1668	194.2		153.9	1274	1519	1668	1864	2007	196.0		151.6
	41	Vallourec & Mannesmann FJL		864	980	1079	1226	177.8	155.5	153.9		912	1030	1128	1274	177.8	153.3	151.6

(1) The closed-end displacement does not account for couplings. MPa × 145 = psi daN × 2.25 = lb daN.m × 7.38 = lb.ft mm × 0.0394 = in

GEOMETRICAL CHARACTERISTICS AND MECHANICAL PROPERTIES OF CASING (continued)

Pipe body	1	Nominal size (OD)	1	7.000 in 177.8 mm					7.000 in 177.8 mm										
	2	Nominal weight	2	35.00 lb/ft 51.1 daN/m					38.00 lb/ft 55.5 daN/m										
	3	Wall thickness	3	0.498 in 12.6 mm					0.540 in 13.7 mm										
	4	Inside diameter	4	6.004 in 152.5 mm					5.920 in 150.4 mm										
	5	Steel cross-section	5	10.17 in ² 6563 mm ²					10.96 in ² 7070 mm ²										
	6	Capacity	6	1.47 gal/ft 18.27 l/m					1.43 gal/ft 17.76 l/m										
	7	Displacement (1)	7	2.00 gal/ft 24.83 l/m					2.00 gal/ft 24.83 l/m										
	8	Grade	8	K55	L80	N80	C90	T95	P110	Q125	K55	L80	N80	C90	T95	P110	Q125		
	9	Collapse resistance (MPa)	9	50.1	70.2	70.2	77.0	80.3	89.8	98.7	54.0	78.5	78.5	88.4	92.6	104.3	115.4		
	10	Internal yield pressure (MPa)	10	47.2	68.7	68.7	77.3	81.5	94.4	107.3	51.2	74.5	74.5	83.8	88.4	102.4	116.3		
	11	Pipe body yield strength (1000 daN)	11	249	362	362	407	430	498	566	268	390	390	439	463	536	609		
Tensile strength (10 ³ daN)	12	Buttress Standard	12	355	370	390	390	409	487	526	370	370	390	390	409	487	526		
	13	Buttress Special Clearance	13	237	237	250	250	262	312	337	237	237	250	250	262	312	337		
	14	API STC	14	232	297	302	328	346	403	452	254	324	330	358	377	440	493		
	15	API LTC	15	256	327	332	360	379	443	492	280	356	362	393	414	483	537		
Connection efficiency	16	Grant Prideco TCII	16																
	17	Grant Prideco STL	17	67.9					68.6										
	18	Hydril LX	18	80.7					81.8										
	19	Hydril 563	19	89.4					90.1										
	20	Hydril 511	20																
	21	Hydril 521	21																
	22	Vallourec & Mannesmann New VAM	22	89.1					82.7										
	23	Vallourec & Mannesmann VAM ACE	23	117.4					108.9										
	24	Vallourec & Mannesmann VAM PRO	24	91.0					85.0										
	25	Vallourec & Mannesmann VAM TOP	25	102.0					101.9										
	26	Vallourec & Mannesmann FJL	26	65.3					65.3										
Connection characteristics				Make-up torque (daN.m)								Make-up torque (daN.m)							
				K55	L80	C90/95	P110	Q125	OD (mm)	ID (mm)	Drift API (mm)	K55	L80	C90/95	P110	Q125	OD (mm)	ID (mm)	Drift API (mm)
	27	Buttress Standard	27						194.5		149.3						194.5		147.2
	28	Buttress Special Clearance	28						187.3		149.3						187.3		147.2
	29	API STC	29																
	30	API LTC	30		1003	1157	1350	1512	194.5		149.3		1095	1262	1474	1649	194.5		147.2
	31	Grant Prideco TCII	31		1769	1769	1769	1769	196.7	154.2	149.3		2020	2020	2020	2020	198.3	152.3	147.2
	32	Grant Prideco STL	32	705	895	895	895	895	177.8	150.5	149.3	773	976	976	976	976	177.8	148.3	147.2
	33	Hydril LX	33	976	1173	1322	1437	1546	181.5	150.5	149.3	1017	1213	1342	1451	1559	182.1	150.1	147.2
	34	Hydril 563	34	2007	2007	2007	2007	2007	196.8	151.2	149.3	2196	2196	2196	2196	2196	196.8	149.1	147.2
	35	Hydril 511	35																
	36	Hydril 521	36																
	37	Vallourec & Mannesmann New VAM	37	1274	1424	1519	1620	1715	195.1		149.3	1322	1519	1566	1668	1763	195.1		147.2
	38	Vallourec & Mannesmann VAM ACE	38	1471	1763	1959	2156	2156	200.9		149.3	1668	2061	2156	2156	2156	200.9		147.2
	39	Vallourec & Mannesmann VAM PRO	39						195.0		149.3						195.0		147.2
	40	Vallourec & Mannesmann VAM TOP	40	1471	1817	2061	2257	2454	197.8		149.3	1715	2102	2352	2549	2847	199.4		147.2
	41	Vallourec & Mannesmann FJL	41		961	1079	1177	1325	177.8	151.3	149.3		1030	1128	1226	1376	177.8	149.2	147.2

(1) The closed-end displacement does not account for couplings. MPa × 145 = psi daN × 2.25 = lb daN.m × 7.38 = lb.ft mm × 0.0394 = in

GEOMETRICAL CHARACTERISTICS AND MECHANICAL PROPERTIES OF CASING (continued)

Pipe body	1	Nominal size (OD)	1	7.000 in					177.8 mm					7.000 in					177.8 mm					
	2	Nominal weight	2	41.00 lb/ft					59.8 daN/m					44.00 lb/ft					64.2 daN/m					
	3	Wall thickness	3	0.590 in					15.0 mm					0.640 in					16.3 mm					
	4	Inside diameter	4	5.820 in					147.8 mm					5.720 in					145.3 mm					
	5	Steel cross-section	5	11.88 in ²					7665 mm ²					12.79 in ²					8250 mm ²					
	6	Capacity	6	1.38 gal/ft					17.16 l/m					1.33 gal/ft					16.58 l/m					
	7	Displacement (1)	7	2.00 gal/ft					24.83 l/m					2.00 gal/ft					24.83 l/m					
	8	Grade	8	K55	L80	N80	C90	T95	P110	Q125	K55	L80	N80	C90	T95	P110	Q125	K55	L80	N80	C90	T95	P110	Q125
9	Collapse resistance (MPa)	9	58.5	85.1	85.1	95.8	101.1	117.1	133.0	63.0	91.6	91.6	103.1	108.8	126.0	143.2	63.0	91.6	91.6	103.1	108.8	126.0	143.2	
10	Internal yield pressure (MPa)	10	55.9	81.4	81.4	91.5	96.6	111.9	127.1	60.7	88.3	88.3	99.3	104.8	121.3	137.9	60.7	88.3	88.3	99.3	104.8	121.3	137.9	
11	Pipe body yield strength (1000 daN)	11	291	423	423	476	502	581	661	313	455	455	512	540	626	711	313	455	455	512	540	626	711	
Tensile strength (10 ³ daN)	12	Buttress Standard	12	370	370	390	390	409	487	526	370	370	390	390	409	487	526	370	370	390	390	409	487	526
	13	Buttress Special Clearance	13	237	237	250	250	262	312	337	237	237	250	250	262	312	337	237	237	250	250	262	312	337
	14	API STC	14	279	356	362	393	414	483	541	303	387	394	427	450	526	589	303	387	394	427	450	526	589
	15	API LTC	15	307	391	398	431	455	531	589	334	426	433	469	495	577	641	334	426	433	469	495	577	641
Connection efficiency	16	Grant Prideco TCII	16											65.0										
	17	Grant Prideco STL	17						68.1															
	18	Hydril LX	18						82.2															
	19	Hydril 563	19						90.9															
	20	Hydril 511	20																					
	21	Hydril 521	21																					
	22	Vallourec & Mannesmann New VAM	22						76.3					70.9										
	23	Vallourec & Mannesmann VAM ACE	23						103.7															
	24	Vallourec & Mannesmann VAM PRO	24						85.0					79.0										
	25	Vallourec & Mannesmann VAM TOP	25						102.0															
26	Vallourec & Mannesmann FJL	26						65.1																
Connection characteristics	27	Buttress Standard	27	Make-up torque (daN.m)					OD (mm)	ID (mm)	Drift-API (mm)	Make-up torque (daN.m)					OD (mm)	ID (mm)	Drift-API (mm)					
	28	Buttress Special Clearance	28						194.5		144.7						194.5		142.1					
	29	API STC	29						187.3		144.7						187.3		142.1					
	30	API LTC	30																					
	31	Grant Prideco TCII	31																					
	32	Grant Prideco STL	32	841	1071	1071	1071	1071	177.8	145.9	144.7	841	1071	1071	1071	1071	177.8	146.3	142.1					
	33	Hydril LX	33	1173	1376	1491	1627	1830	181.9	145.8	144.7													
	34	Hydril 563	34	2346	2346	2346	2346	2346	196.8		144.7													
	35	Hydril 511	35																					
	36	Hydril 521	36																					
	37	Vallourec & Mannesmann New VAM	37	1424	1566	1668	1763	1864	195.1		144.7	1668	1864	1959	2061	2156	195.1		142.1					
	38	Vallourec & Mannesmann VAM ACE	38	1959	2156	2156	2156	2156	201.7		144.7													
	39	Vallourec & Mannesmann VAM PRO	39						195.0		144.7					195.0		142.1						
	40	Vallourec & Mannesmann VAM TOP	40	1959	2454	2746	2942	3139	201.4		144.7													
	41	Vallourec & Mannesmann FJL	41		1079	1177	1325	1424	177.8	146.6	144.7													

(1) The closed-end displacement does not account for couplings. MPa × 145 = psi daN × 2.25 = lb daN.m × 7.38 = lb.ft mm × 0.0394 = in

GEOMETRICAL CHARACTERISTICS AND MECHANICAL PROPERTIES OF CASING (continued)

Pipe body	1	Nominal size (OD)	1	7.000 in		177.8 mm		7.625 in		193.7 mm										
	2	Nominal weight	2	46.00 lb/ft		67.1 daN/m		26.40 lb/ft		38.5 daN/m										
	3	Wall thickness	3	0.670 in		17.0 mm		0.328 in		8.3 mm										
	4	Inside diameter	4	5.660 in		143.8 mm		6.969 in		177.0 mm										
	5	Steel cross-section	5	13.32 in ²		8596 mm ²		7.52 in ²		4851 mm ²										
	6	Capacity	6	1.31 gal/ft		16.23 l/m		1.98 gal/ft		24.61 l/m										
	7	Displacement (1)	7	2.00 gal/ft		24.83 l/m		2.37 gal/ft		29.46 l/m										
	8	Grade	8	K55	L80	N80	C90	T95	P110	Q125	K55	L80	N80	C90	T95	P110	Q125			
	9	Collapse resistance (MPa)	9	65.6	95.5	95.5	107.4	113.4	131.3	149.2	20.0	23.5	23.5	24.9	25.6	27.1	27.9			
	10	Internal yield pressure (MPa)	10	63.5	92.4	92.4	103.9	109.7	127.0	144.4	28.5	41.5	41.5	46.7	49.3	57.1	64.9			
	11	Pipe body yield strength (1000 daN)	11	326	474	474	533	563	652	741	184	268	268	301	318	368	418			
Tensile strength (10 ³ daN)	12	Buttress Standard	12	370	370	390	390	409	487	526	258	282	293	303	318	376	412			
	13	Buttress Special Clearance	13	237	237	250	250	262	312	337	258	282	293	303	318	376	412			
	14	API STC	14	317	406	412	448	472	551	617	152	196	198	216	227	265	297			
	15	API LTC	15	350	446	453	492	518	605	672	167	214	218	237	249	291	326			
	16	Grant Prideco TCII	16																	
Connection efficiency	17	Grant Prideco STL	17	64.6						58.2										
	18	Hydril LX	18							74.1										
	19	Hydril 563	19							90.0										
	20	Hydril 511	20							61.6										
	21	Hydril 521	21							67.7										
	22	Vallourec & Mannesmann New VAM	22	68.0						171.6										
	23	Vallourec & Mannesmann VAM ACE	23							166.8										
	24	Vallourec & Mannesmann VAM PRO	24	75.0						100.0										
	25	Vallourec & Mannesmann VAM TOP	25																	
	26	Vallourec & Mannesmann FJL	26							51.8										
	Connection characteristics	27	Buttress Standard	27	Make-up torque (daN.m)					OD (mm)	ID (mm)	Drift API (mm)	Make-up torque (daN.m)					OD (mm)	ID (mm)	Drift API (mm)
28		Buttress Special Clearance	28	K55	L80	C90/95	P110	Q125	194.5	140.6	140.6	K55	L80	C90/95	P110	Q125	215.9	173.8	173.8	
29		API STC	29									464					215.9	173.8	173.8	
30		API LTC	30									511	659	759			215.9	173.8	173.8	
31		Grant Prideco TCII	31										1044	1044	1044	205.9	175.5	173.8	173.8	
32		Grant Prideco STL	32	881	1112	1112	1112	1112	177.8	147.3	140.6	447	576	576	576	576	193.7	175.0	173.8	173.8
33		Hydril LX	33									929	1166	1308	1430	1620	196.7	175.0	173.8	173.8
34		Hydril 563	34									1058	1058	1058	1058	1058	215.9	175.7	173.8	173.8
35		Hydril 511	35									583	583	583	583	583	193.7	174.8	173.8	173.8
36		Hydril 521	36									976	976	976	976	976	199.8	175.1	173.8	173.8
37		Vallourec & Mannesmann New VAM	37	1763	1912	1959	2061	2156	195.1		140.6	971	1079	1180	1227	1322	216.6		173.8	173.8
38		Vallourec & Mannesmann VAM ACE	38									735	834	931	1029	1125	215.9		173.8	173.8
39		Vallourec & Mannesmann VAM PRO	39						195.0		140.6						216.4		173.8	173.8
40		Vallourec & Mannesmann VAM TOP	40																173.8	173.8
41		Vallourec & Mannesmann FJL	41										961	1128	1274	1424	193.7	175.4	173.8	173.8

(1) The closed-end displacement does not account for couplings. MPa × 145 = psi daN × 2.25 = lb daN.m × 7.38 = lb.ft mm × 0.0394 = in

GEOMETRICAL CHARACTERISTICS AND MECHANICAL PROPERTIES OF CASING (continued)

			7.625 in 193.7 mm							7.625 in 193.7 mm										
			29.70 lb/ft 43.3 daN/m							33.70 lb/ft 49.2 daN/m										
Pipe body	1	Nominal size (OD)	1	7.625 in 193.7 mm							7.625 in 193.7 mm									
	2	Nominal weight	2	29.70 lb/ft 43.3 daN/m							33.70 lb/ft 49.2 daN/m									
	3	Wall thickness	3	0.375 in 9.5 mm							0.430 in 10.9 mm									
	4	Inside diameter	4	6.875 in 174.6 mm							6.765 in 171.8 mm									
	5	Steel cross-section	5	8.54 in ² 5510 mm ²							9.72 in ² 6271 mm ²									
	6	Capacity	6	1.93 gal/ft 23.95 l/m							1.87 gal/ft 23.19 l/m									
	7	Displacement (1)	7	2.37 gal/ft 29.46 l/m							2.37 gal/ft 29.46 l/m									
	8	Grade	8	K55	L80	N80	C90	T95	P110	Q125	K55	L80	N80	C90	T95	P110	Q125			
	9	Collapse resistance (MPa)	9	27.0	33.0	33.0	34.7	35.4	36.9	39.1	35.1	45.2	45.2	48.6	50.2	54.3	57.5			
	10	Internal yield pressure (MPa)	10	32.6	47.5	47.5	53.4	56.4	65.3	74.2	37.4	54.4	54.4	61.2	64.6	74.8	85.1			
	11	Pipe body yield strength (1000 daN)	11	209	304	304	342	361	418	475	238	346	346	389	411	476	540			
Tensile strength (10 ³ daN)	12	Buttress Standard	12	293	321	333	344	362	427	468	334	365	379	391	412	486	533			
	13	Buttress Special Clearance	13	293	321	333	344	361	427	465	327	327	344	344	361	430	465			
	14	API STC	14	179	230	233	254	267	312	350	210	269	273	297	313	366	410			
	15	API LTC	15	197	252	256	278	293	342	383	231	295	300	326	343	401	449			
Connection efficiency	16	Grant Prideco TCII	16																	
	17	Grant Prideco STL	17	65.0							66.8									
	18	Hydril LX	18	74.4							78.4									
	19	Hydril 563	19	91.2							92.3									
	20	Hydril 511	20	61.1							60.1									
	21	Hydril 521	21	71.2							74.3									
	22	Vallourec & Mannesmann New VAM	22	151.0							132.7									
	23	Vallourec & Mannesmann VAM ACE	23	146.9							129.0									
	24	Vallourec & Mannesmann VAM PRO	24	100.0							100.0									
	25	Vallourec & Mannesmann VAM TOP	25	102.0							102.0									
	26	Vallourec & Mannesmann FJL	26	57.5							62.7									
Connection characteristics	27	Buttress Standard	27	Make-up torque (daN.m)					OD (mm)	ID (mm)	Drift API (mm)	Make-up torque (daN.m)					OD (mm)	ID (mm)	Drift API (mm)	
				K55	L80	C90/95	P110	Q125				K55	L80	C90/95	P110	Q125				
	28	Buttress Special Clearance	28						215.9		171.4							215.9		168.7
	29	API STC	29					206.4		171.4							206.4		168.7	
	30	API LTC	30		774	893	1043		215.9		171.4		907	1047	1222		215.9		168.7	
	31	Grant Prideco TCII	31		1342	1342	1342	1342	207.9	173.0	171.4		1458	1458	1458	1458	210.2	173.0	168.7	
	32	Grant Prideco STL	32	569	719	719	719	719	193.7	172.3	171.4	664	841	841	841	841	193.7	169.8	168.7	
	33	Hydril LX	33	1071	1322	1444	1559	1763	196.9	172.6	171.4	1003	1220	1335	1458	1627	197.2	169.8	168.7	
	34	Hydril 563	34	1166	1166	1166	1166	1166	215.9		171.4	1369	1369	1369	1369	1369	215.9		168.7	
	35	Hydril 511	35	922	922	922	922	922	193.7	172.4	171.4	1180	1180	1180	1180	1180	193.7	169.6	168.7	
	36	Hydril 521	36	1139	1139	1139	1139	1139	201.9	172.7	171.4	1329	1329	1329	1329	1329	204.1	169.9	168.7	
	37	Vallourec & Mannesmann New VAM	37	1125	1274	1376	1471	1566	216.6		171.4	1376	1566	1668	1817	1912	216.6		168.7	
	38	Vallourec & Mannesmann VAM ACE	38	980	1180	1274	1376	1471	215.9		171.4	1180	1376	1566	1668	1763	215.9		168.7	
	39	Vallourec & Mannesmann VAM PRO	39						216.4		171.4						216.4		168.7	
	40	Vallourec & Mannesmann VAM TOP	40	1079	1274	1471	1668	1763	208.6		171.4	1180	1376	1566	1763	1864	210.9		168.7	
	41	Vallourec & Mannesmann FJL	41		980	1128	1274	1424	193.7	173.1	171.4		1030	1177	1325	1471	193.7	170.4	168.7	

(1) The closed-end displacement does not account for couplings. MPa × 145 = psi daN × 2.25 = lb daN.m × 7.38 = lb.ft mm × 0.0394 = in

GEOMETRICAL CHARACTERISTICS AND MECHANICAL PROPERTIES OF CASING (continued)

		7.625 in 193.7 mm								7.625 in 193.7 mm							
		35.80 lb/ft 52.2 daN/m								39.00 lb/ft 56.9 daN/m							
Pipe body	1	Nominal size (OD)		7.625 in 193.7 mm		7.625 in 193.7 mm											
	2	Nominal weight		35.80 lb/ft 52.2 daN/m		39.00 lb/ft 56.9 daN/m											
	3	Wall thickness		0.465 in 11.8 mm		0.500 in 12.7 mm											
	4	Inside diameter		6.695 in 170.1 mm		6.625 in 168.3 mm											
	5	Steel cross-section		10.46 in ² 6748 mm ²		11.19 in ² 7221 mm ²											
	6	Capacity		1.83 gal/ft 22.71 l/m		1.79 gal/ft 22.24 l/m											
	7	Displacement (1)		2.37 gal/ft 29.46 l/m		2.37 gal/ft 29.46 l/m											
Tensile strength (10 ³ daN)	8	Grade		K55 L80 N80 C90 T95 P110 Q125		K55 L80 N80 C90 T95 P110 Q125											
	9	Collapse resistance (MPa)		40.3 53.0 53.0 57.5 59.6 65.3 70.3		45.5 60.8 60.8 66.3 68.9 76.4 83.1											
	10	Internal yield pressure (MPa)		40.5 58.9 58.9 66.2 69.9 80.9 92.0		43.5 63.3 63.3 71.2 75.2 87.0 98.9											
	11	Pipe body yield strength (1000 daN)		256 372 372 419 442 512 582		274 398 398 448 473 548 622											
Connection efficiency	12	Buttress Standard		359 393 408 421 443 523 573		385 420 436 451 474 560 613											
	13	Buttress Special Clearance		327 327 344 344 361 430 465		327 327 344 344 361 430 465											
	14	API STC		229 294 299 325 342 399 448		248 319 324 352 371 433 485											
	15	API LTC		252 323 328 356 375 438 490		273 350 355 386 406 474 531											
Connection characteristics	16	Grant Prideco TCII															
	17	Grant Prideco STL												63.8			
	18	Hydril LX												79.2			
	19	Hydril 563												89.5			
	20	Hydril 511															
	21	Hydril 521												77.3			
	22	Vallourec & Mannesmann New VAM				123.3								115.2			
	23	Vallourec & Mannesmann VAM ACE				119.9								112.1			
	24	Vallourec & Mannesmann VAM PRO				100.0								100.0			
	25	Vallourec & Mannesmann VAM TOP				102.0								102.0			
	26	Vallourec & Mannesmann FJL				65.2								65.2			
Connection characteristics	27	Buttress Standard															
	28	Buttress Special Clearance															
	29	API STC															
	30	API LTC															
	31	Grant Prideco TCII		1668 1668		1668 1668		211.7 171.5		166.9				215.9 165.1			
	32	Grant Prideco STL												206.4 165.1			
	33	Hydril LX															
	34	Hydril 563															
	35	Hydril 511															
	36	Hydril 521															
	37	Vallourec & Mannesmann New VAM		1424 1620		1763 1864		1959 216.6		166.9		1471 1668		1817 1912		2061 216.6	
	38	Vallourec & Mannesmann VAM ACE		1376 1566		1763 1864		1959 215.9		166.9		1566 1763		1959 2061		2156 215.9	
	39	Vallourec & Mannesmann VAM PRO						216.4		166.9				216.4		165.1	
	40	Vallourec & Mannesmann VAM TOP		1376 1668		1864 2061		2257 212.4		166.9		1566 1959		2156 2454		2746 213.8	
	41	Vallourec & Mannesmann FJL		1079 1226		1376 1519		193.7 168.8		166.9		1128 1274		1424 1566		193.7 167.0	

(1) The closed-end displacement does not account for couplings. MPa × 145 = psi daN × 2.25 = lb daN.m × 7.38 = lb.ft mm × 0.0394 = in

GEOMETRICAL CHARACTERISTICS AND MECHANICAL PROPERTIES OF CASING (continued)

Pipe body	1	Nominal size (OD)	1	7.625 in 193.7 mm		7.625 in 193.7 mm													
	2	Nominal weight	2	42.80 lb/ft 62.5 daN/m		45.30 lb/ft 66.1 daN/m													
	3	Wall thickness	3	0.562 in 14.3 mm		0.595 in 15.1 mm													
	4	Inside diameter	4	6.501 in 165.1 mm		6.435 in 163.4 mm													
	5	Steel cross-section	5	12.47 in ² 8045 mm ²		13.14 in ² 8478 mm ²													
	6	Capacity	6	1.72 gal/ft 21.41 l/m		1.69 gal/ft 20.98 l/m													
	7	Displacement (1)	7	2.37 gal/ft 29.46 l/m		2.37 gal/ft 29.46 l/m													
	8	Grade	8	K55 L80 N80 C90 T95 P110 Q125	K55 L80 N80 C90 T95 P110 Q125														
	9	Collapse resistance (MPa)	9	51.8 74.6 74.6 82.0 85.6 96.0 105.8	54.6 79.4 79.4 89.3 94.2 106.5 117.9														
	10	Internal yield pressure (MPa)	10	48.9 71.1 71.1 80.0 84.5 97.8 111.2	51.8 75.3 75.3 84.7 89.4 103.6 117.7														
	11	Pipe body yield strength (1000 daN)	11	305 444 444 499 527 610 693	321 468 468 526 555 643 731														
Tensile strength (10 ³ daN)	12	Buttress Standard	12	428 468 486 502 528 624 683	451 493 512 529 556 657 720														
	13	Buttress Special Clearance	13	327 327 344 344 361 430 465	327 327 344 344 361 430 465														
	14	API STC	14	281 362 367 399 421 491 550	299 384 390 424 447 522 584														
	15	API LTC	15	310 397 403 437 461 538 603	329 421 428 465 490 572 640														
Connection efficiency	16	Grant Prideco TCII	16																
	17	Grant Prideco STL	17	69.5			69.9												
	18	Hydril LX	18	81.6			82.3												
	19	Hydril 563	19	90.6			91.0												
	20	Hydril 511	20																
	21	Hydril 521	21																
	22	Vallourec & Mannesmann New VAM	22	103.5			98.2												
	23	Vallourec & Mannesmann VAM ACE	23	102.0			102.0												
	24	Vallourec & Mannesmann VAM PRO	24	100.0			100.0												
	25	Vallourec & Mannesmann VAM TOP	25																
26	Vallourec & Mannesmann FJL	26	65.1			66.0													
Connection characteristics			Make-up torque (daN.m)					OD (mm)	ID (mm)	Drift API (mm)	Make-up torque (daN.m)					OD (mm)	ID (mm)	Drift API (mm)	
			K55	LN80	C90/95	P110	Q125				K55	LN80	C90/95	P110	Q125				
	27	Buttress Standard	27					215.9		162.0				215.9		160.3			
	28	Buttress Special Clearance	28					206.4		162.0				206.4		160.3			
	29	API STC	29																
	30	API LTC	30																
	31	Grant Prideco TCII	31		1218	1406	1641	1837	215.9		162.0								
	32	Grant Prideco STL	32		2285	2285	2285	2285	215.6	167.2	162.0								
	33	Hydril LX	33	1200	1458	1559	1695	1898	197.8	163.1	162.0	936	1180	1180	1180	1180	193.7	162.8	160.3
	34	Hydril 563	34	2413	2413	2413	2413	2413	215.9		162.0	1288	1491	1695	1830	1966	197.9	161.4	160.3
	35	Hydril 511	35									2576	2576	2576	2576	2576	215.9		160.3
	36	Hydril 521	36																
	37	Vallourec & Mannesmann New VAM	37	1620	1817	1912	2061	2156	216.6		162.0	1668	1864	1959	2061	2156	216.6		160.3
	38	Vallourec & Mannesmann VAM ACE	38	1864	2061	2156	2156	2156	216.2		162.0	2061	2156	2156	2156	2156	217.5		160.3
	39	Vallourec & Mannesmann VAM PRO	39						216.4		162.0						216.4		160.3
	40	Vallourec & Mannesmann VAM TOP	40																
	41	Vallourec & Mannesmann FJL	41		1177	1325	1471	1620	193.7	163.9	162.0		1177	1376	1519	1715	193.7	162.2	160.3

(1) The closed-end displacement does not account for couplings. MPa x 145 = psi daN x 2.25 = lb daN.m x 7.38 = lb.ft mm x 0.0394 = in

GEOMETRICAL CHARACTERISTICS AND MECHANICAL PROPERTIES OF CASING (continued)

		Pipe body								Pipe body															
		1	2	3	4	5	6	7	8	9	10	11	12	13	14	15	16	17	18	19	20	21	22	23	24
	1	Nominal size (OD)	7.625 in 193.7 mm								8.625 in 219.1 mm														
	2	Nominal weight	47.10 lb/ft 68.7 daN/m								28.00 lb/ft 40.9 daN/m														
	3	Wall thickness	0.625 in 15.9 mm								0.304 in 7.7 mm														
	4	Inside diameter	6.375 in 161.9 mm								8.017 in 203.6 mm														
	5	Steel cross-section	13.74 in ² 8867 mm ²								7.95 in ² 5127 mm ²														
	6	Capacity	1.66 gal/ft 20.59 l/m								2.62 gal/ft 32.57 l/m														
	7	Displacement (1)	2.37 gal/ft 29.46 l/m								3.04 gal/ft 37.69 l/m														
	8	Grade	K55 L80 N80 C90 T95 P110 Q125								K55 L80 N80 C90 T95 P110 Q125														
	9	Collapse resistance (MPa)	57.1 83.0 83.0 93.4 98.6 114.1 128.9								13.0 14.9 14.9 15.2 15.2 15.2 15.2														
	10	Internal yield pressure (MPa)	54.4 79.1 79.1 89.0 94.0 108.8 123.6								23.4 34.0 34.0 38.3 40.4 46.8 53.2														
	11	Pipe body yield strength (1000 daN)	336 489 489 550 581 673 764								194 283 283 318 336 389 442														
Tensile strength (10 ³ daN)	12	Buttress Standard	472 516 536 551 579 687 744								267 295 306 318 334 394 433														
	13	Buttress Special Clearance	327 327 344 344 361 430 465								267 295 306 318 334 394 433														
	14	API STC	315 404 411 446 470 549 615								149 193 196 213 225 262 294														
	15	API LTC	346 443 450 489 516 602 674								168 216 219 239 252 293 329														
Connection efficiency	16	Grant Prideco TCII																							
	17	Grant Prideco STL	70.2								57.1														
	18	Hydril LX	82.3																						
	19	Hydril 563																							
	20	Hydril 511																							
	21	Hydril 521																							
	22	Vallourec & Mannesmann New VAM	93.9								206.4														
	23	Vallourec & Mannesmann VAM ACE									202.8														
	24	Vallourec & Mannesmann VAM PRO	100.0								100.0														
	25	Vallourec & Mannesmann VAM TOP																							
26	Vallourec & Mannesmann FJL																								
Connection characteristics			Make-up torque (daN.m)					OD (mm)	ID (mm)	Drift API (mm)	Make-up torque (daN.m)					OD (mm)	ID (mm)	Drift API (mm)							
			K55	LN80	C90/95	P110	Q125				K55	LN80	C90/95	P110	Q125										
	27	Buttress Standard						215.9						244.5			200.5								
	28	Buttress Special Clearance						206.4						231.8			200.5								
	29	API STC																							
	30	API LTC		1367	1571	1834	2054	215.9																	
	31	Grant Prideco TCII		2712	2712	2712	2712	224.8	164.4		976	976	976	976	230.7	202.1	200.5								
	32	Grant Prideco STL	976	1241	1241	1241	1241	193.7	161.5		461	583	583	583	219.1	202.2	200.5								
	33	Hydril LX	1383	1627	1830	1966	2169	198.1	159.9																
	34	Hydril 563																							
	35	Hydril 511																							
	36	Hydril 521																							
	37	Vallourec & Mannesmann New VAM	1715	1912	2061	2156	2156	216.6			1029	1180	1274	1376	1471	245.1	200.5								
	38	Vallourec & Mannesmann VAM ACE									735	834	883	931	980	244.5	200.5								
	39	Vallourec & Mannesmann VAM PRO						216.4								244.5	200.5								
40	Vallourec & Mannesmann VAM TOP																								
41	Vallourec & Mannesmann FJL																								

(1) The closed-end displacement does not account for couplings. MPa × 145 = psi daN × 2.25 = lb daN.m × 7.38 = lb.ft mm × 0.0394 = in

GEOMETRICAL CHARACTERISTICS AND MECHANICAL PROPERTIES OF CASING (continued)

	Pipe body							Tensile strength (10 ³ daN)							Connection efficiency							Connection characteristics																		
	1	2	3	4	5	6	7	8	9	10	11	12	13	14	15	16	17	18	19	20	21	22	23	24	25	26	27	28	29	30	31	32	33	34	35	36	37	38	39	40
	Nominal size (OD)	8.625 in 219.1 mm							8.625 in 219.1 mm																															
	Nominal weight	32.00 lb/ft 46.7 daN/m							36.00 lb/ft 52.5 daN/m																															
	Wall thickness	0.352 in 8.9 mm							0.400 in 10.2 mm																															
	Inside diameter	7.921 in 201.2 mm							7.825 in 198.8 mm																															
	Steel cross-section	9.15 in ² 5902 mm ²							10.34 in ² 6668 mm ²																															
	Capacity	2.56 gal/ft 31.79 l/m							2.50 gal/ft 31.03 l/m																															
	Displacement (1)	3.04 gal/ft 37.69 l/m							3.04 gal/ft 37.69 l/m																															
	Grade	K55 L80 N80 C90 T95 P110 Q125							K55 L80 N80 C90 T95 P110 Q125																															
	Collapse resistance (MPa)	17.5 21.0 21.0 22.2 22.6 23.6 23.9							23.8 28.3 28.3 29.3 30.0 32.3 34.0																															
	Internal yield pressure (MPa)	27.1 39.4 39.4 44.3 46.8 54.2 61.6							30.8 44.8 44.8 50.4 53.2 61.6 69.9																															
	Pipe body yield strength (1000 daN)	224 326 326 366 387 448 509							253 368 368 414 437 506 575																															
	Buttress Standard	307 340 352 366 384 454 498							347 384 398 413 434 512 563																															
	Buttress Special Clearance	307 340 352 366 384 454 498							347 373 393 393 412 491 530																															
	API STC	179 232 235 256 270 315 353							208 270 273 298 314 366 411																															
	API LTC	201 259 263 286 302 352 394							234 302 306 333 351 410 459																															
	Grant Prideco TCII																																							
	Grant Prideco STL	59.3							66.0																															
	Hydril LX								73.3																															
	Hydril 563	90.7							91.8																															
	Hydril 511	57.3							61.4																															
	Hydril 521	68.1							71.4																															
	Vallourec & Mannesmann New VAM	179.3							158.7																															
	Vallourec & Mannesmann VAM ACE	176.2							156.0																															
	Vallourec & Mannesmann VAM PRO	100.0							100.0																															
	Vallourec & Mannesmann VAM TOP								102.1																															
	Vallourec & Mannesmann FJL	54.5							59.7																															
		Make-up torque (daN.m)					OD (mm)	ID (mm)	Drift API (mm)	Make-up torque (daN.m)					OD (mm)	ID (mm)	Drift API (mm)																							
		K55	LN80	C90/95	P110	Q125				K55	LN80	C90/95	P110	Q125																										
	Buttress Standard						244.5		198.0						244.5		195.6																							
	Buttress Special Clearance						231.8		198.0						231.8		195.6																							
	API STC	545					244.5		198.0	635					244.5		195.6																							
	API LTC	613					244.5		198.0	713	926	1070			244.5		195.6																							
	Grant Prideco TCII		1369	1369	1369	1369	232.8	199.7	198.0		1478	1478	1478	1478	234.9	199.7	195.6																							
	Grant Prideco STL		556	705	705	705	219.1	200.2	198.0	691	881	881	881	881	219.1	196.9	195.6																							
	Hydril LX									1173	1458	1627	1763	1966	222.6	196.7	195.6																							
	Hydril 563	1274	1274	1274	1274	1274	244.5	201.6	198.0	1424	1424	1424	1424	1424	244.5		195.6																							
	Hydril 511	746	746	746	746	746	219.1	201.1	198.0	1098	1098	1098	1098	1098	219.1	196.7	195.6																							
	Hydril 521	1166	1166	1166	1166	1166	225.8	201.3	198.0	1383	1383	1383	1383	1383	227.8	196.8	195.6																							
	Vallourec & Mannesmann New VAM	1125	1274	1376	1471	1566	245.1		198.0	1376	1566	1668	1817	1959	245.1		195.6																							
	Vallourec & Mannesmann VAM ACE	883	980	1079	1180	1274	244.5		198.0	1079	1227	1376	1471	1566	244.5		195.6																							
	Vallourec & Mannesmann VAM PRO						244.5		198.0						244.5		195.6																							
	Vallourec & Mannesmann VAM TOP									1079	1227	1376	1471	1566	235.4		195.6																							
	Vallourec & Mannesmann FJL		1226	1424	1620	1817	219.1	199.7	198.0		1274	1471	1668	1864	219.1	197.3	195.6																							

(1) The closed-end displacement does not account for couplings. MPa × 145 = psi daN × 2.25 = lb daN.m × 7.38 = lb.ft mm × 0.0394 = in

GEOMETRICAL CHARACTERISTICS AND MECHANICAL PROPERTIES OF CASING (continued)

	Pipe body								Pipe body																		
	1	2	3	4	5	6	7	8	9	10	11	12	13	14	15	16	17	18	19	20	21	22	23	24	25	26	
	Nominal size (OD)		8.625 in	219.1 mm					8.625 in	219.1 mm																	
	Nominal weight		40.00 lb/ft	58.4 daN/m					44.00 lb/ft	64.2 daN/m																	
	Wall thickness		0.450 in	11.4 mm					0.500 in	12.7 mm																	
	Inside diameter		7.725 in	196.2 mm					7.625 in	193.7 mm																	
	Steel cross-section		11.56 in ²	7456 mm ²					12.76 in ²	8234 mm ²																	
	Capacity		2.43 gal/ft	30.24 l/m					2.37 gal/ft	29.46 l/m																	
	Displacement (1)		3.04 gal/ft	37.69 l/m					3.04 gal/ft	37.69 l/m																	
	Grade		K55	L80	N80	C90	T95	P110	Q125	K55	L80	N80	C90	T95	P110	Q125											
	Collapse resistance (MPa)		30.3	38.1	38.1	40.5	41.5	44.1	45.7	36.9	47.9	47.9	51.7	53.4	58.1	61.9											
	Internal yield pressure (MPa)		34.6	50.4	50.4	56.7	59.8	69.2	78.7	38.5	56.0	56.0	63.0	66.4	76.9	87.4											
	Pipe body yield strength (1000 daN)		283	411	411	463	488	565	643	312	454	454	511	539	624	710											
Tensile strength (10 ³ daN)	Buttress Standard	12	388	430	445	462	486	573	629	428	474	492	510	536	633	695											
	Buttress Special Clearance	13	373	373	393	393	412	491	530	373	373	393	393	412	491	530											
	API STC	14	239	309	313	341	360	419	470	268	347	352	384	405	472	529											
	API LTC	15	268	345	351	381	402	469	526	302	389	394	429	452	528	592											
Connection efficiency	Grant Prideco TCII	16																									
	Grant Prideco STL	17				67.3																					
	Hydril LX	18				75.7																					
	Hydril 563	19				92.6																					
	Hydril 511	20				58.6																					
	Hydril 521	21				74.2																					
	Vallourec & Mannesmann New VAM	22				141.9																					
	Vallourec & Mannesmann VAM ACE	23				139.5																					
	Vallourec & Mannesmann VAM PRO	24				100.0																					
	Vallourec & Mannesmann VAM TOP	25				102.1																					
	Vallourec & Mannesmann FJL	26				63.9																					
Connection characteristics	Buttress Standard	27								244.5													244.5			190.5	
	Buttress Special Clearance	28								231.8													231.8			190.5	
	API STC	29																									
	API LTC	30																									
	Grant Prideco TCII	31			1060	1226	1430			244.5													244.5			190.5	
	Grant Prideco STL	32			1830	1830	1830	1830	237.1	197.4	193.0												219.6	219.6	219.6	219.6	190.5
	Hydril LX	33	786	1003	1003	1003	1003	219.1	194.7	193.0	759	963	963	963	963	219.1	194.8	190.5									
	Hydril 563	34	1363	1627	1830	1966	2169	222.8	194.6	193.0	1396	1695	1898	2102	2305	223.1	191.6	190.5									
	Hydril 511	35	1627	1627	1627	1627	1627	244.5		193.0	2468	2468	2468	2468	2468	244.5	192.4	190.5									
	Hydril 521	36	1369	1369	1369	1369	1369	219.1	194.8	193.0	1763	1763	1763	1763	1763	232.0	191.8	190.5									
	Vallourec & Mannesmann New VAM	37	1573	1573	1573	1573	1573	229.9	194.9	193.0	1763	1763	1763	1763	1763	232.0	191.8	190.5									
	Vallourec & Mannesmann VAM ACE	38	1471	1668	1817	1912	2061	245.1		193.0	1566	1763	1912	2061	2156	244.5	190.5										
	Vallourec & Mannesmann VAM PRO	39	1376	1566	1763	1864	1959	244.5		193.0	1668	1864	2061	2156	2156	244.5	190.5										
	Vallourec & Mannesmann VAM TOP	40						244.5		193.0						244.5	190.5										
	Vallourec & Mannesmann FJL	41	1376	1668	1864	2061	2257	237.5		193.0	1763	2257	2454	2746	2942	239.6	190.5										
				1325	1519	1668	1864	219.1	194.9	193.0		1376	1566	1763	1959	219.1	192.6	190.5									

(1) The closed-end displacement does not account for couplings. MPa × 145 = psi daN × 2.25 = lb daN.m × 7.38 = lb.ft mm × 0.0394 = in

GEOMETRICAL CHARACTERISTICS AND MECHANICAL PROPERTIES OF CASING (continued)

Pipe body	1	Nominal size (OD)	1	8.625 in					219.1 mm					8.625 in					219.1 mm				
	2	Nominal weight	2	49.00 lb/ft					71.5 daN/m					52.00 lb/ft					75.9 daN/m				
	3	Wall thickness	3	0.557 in					14.1 mm					0.595 in					15.1 mm				
	4	Inside diameter	4	7.511 in					190.8 mm					7.435 in					188.8 mm				
	5	Steel cross-section	5	14.12 in ²					9108 mm ²					15.01 in ²					9684 mm ²				
	6	Capacity	6	2.30 gal/ft					28.59 l/m					2.26 gal/ft					28.01 l/m				
	7	Displacement (1)	7	3.04 gal/ft					37.69 l/m					3.04 gal/ft					37.69 l/m				
	8	Grade	8	K55	L80	N80	C90	T95	P110	Q125	K55	L80	N80	C90	T95	P110	Q125						
	9	Collapse resistance (MPa)	9	44.4	59.1	59.1	64.4	66.9	74.0	80.4	48.7	66.6	66.6	72.9	75.9	84.6	92.7						
	10	Internal yield pressure (MPa)	10	42.9	62.3	62.3	70.1	74.0	85.7	97.4	45.8	66.6	66.6	74.9	79.1	91.6	104.0						
	11	Pipe body yield strength (1000 daN)	11	345	502	502	565	597	691	785	367	534	534	601	634	734	835						
Tensile strength (10 ³ daN)	12	Buttress Standard	12	474	525	544	564	593	700	769	504	558	578	600	631	744	817						
	13	Buttress Special Clearance	13	373	373	393	393	412	491	530	373	373	393	393	412	491	530						
	14	API STC	14	302	391	396	432	455	531	595	324	419	425	463	488	570	639						
	15	API LTC	15	339	437	444	483	509	594	665	364	469	476	518	546	637	714						
Connection efficiency	16	Grant Prideco TCII	16																				
	17	Grant Prideco STL	17						59.1														
	18	Hydril LX	18						79.4					79.0									
	19	Hydril 563	19						90.6					91.1									
	20	Hydril 511	20																				
	21	Hydril 521	21																				
	22	Vallourec & Mannesmann New VAM	22						116.2					109.3									
	23	Vallourec & Mannesmann VAM ACE	23						114.2					107.4									
	24	Vallourec & Mannesmann VAM PRO	24						100.0					100.0									
	25	Vallourec & Mannesmann VAM TOP	25						102.0					102.0									
	26	Vallourec & Mannesmann FJL	26						69.2					65.1									
Connection characteristics	27	Buttress Standard	27	Make-up torque (daN.m)					OD (mm)	ID (mm)	Drift API (mm)	Make-up torque (daN.m)					OD (mm)	ID (mm)	Drift API (mm)				
	28	Buttress Special Clearance	28	K55	LN80	C90/95	P110	Q125				K55	LN80	C90/95	P110	Q125							
	29	API STC	29						244.5		187.6						244.5		185.7				
	30	API LTC	30						231.8		187.6					231.8		185.7					
	31	Grant Prideco TCII	31		1342	1551	1810	2028	244.5		187.6												
	32	Grant Prideco STL	32		2624	2624	2624	2624	241.5	192.7	187.6												
	33	Hydril LX	33	759	963	963	963	963	219.1	192.6	187.6												
	34	Hydril 563	34	1627	1966	2102	2305	2508	223.3	189.2	187.6	1627	1966	2169	2440	2644	223.5	186.8	185.7				
	35	Hydril 511	35	2685	2685	2685	2685	2685	244.5		187.6	2874	2874	2874	2874	2874	244.5		185.7				
	36	Hydril 521	36																				
	37	Vallourec & Mannesmann New VAM	37	1668	1864	2061	2156	2156	245.1		187.6	1763	1959	2061	2156	2156	245.1		185.7				
	38	Vallourec & Mannesmann VAM ACE	38	1959	2156	2156	2156	2156	244.5		187.6	2156	2156	2156	2156	2156	244.5		185.7				
	39	Vallourec & Mannesmann VAM PRO	39						244.5		187.6						244.5		185.7				
	40	Vallourec & Mannesmann VAM TOP	40	2257	2847	3037	3139	3139	242.0		187.6	2549	3139	3139	3139	3139	243.5		185.7				
	41	Vallourec & Mannesmann FJL	41		1471	1620	1817	1959	219.1	189.7	187.6		1519	1715	1912	2061	219.1	187.8	185.7				

(1) The closed-end displacement does not account for couplings. MPa x 145 = psi daN x 2.25 = lb daN.m x 7.38 = lb.ft mm x 0.0394 = in

GEOMETRICAL CHARACTERISTICS AND MECHANICAL PROPERTIES OF CASING (continued)

Pipe body	1	Nominal size (OD)	1	9.625 in 244.5 mm					9.625 in 244.5 mm											
	2	Nominal weight	2	36.00 lb/ft 52.5 daN/m					40.00 lb/ft 58.4 daN/m											
	3	Wall thickness	3	0.352 in 8.9 mm					0.395 in 10.0 mm											
	4	Inside diameter	4	8.921 in 226.6 mm					8.835 in 224.4 mm											
	5	Steel cross-section	5	10.25 in ² 6616 mm ²					11.45 in ² 7390 mm ²											
	6	Capacity	6	3.25 gal/ft 40.33 l/m					3.18 gal/ft 39.55 l/m											
	7	Displacement (1)	7	3.78 gal/ft 46.94 l/m					3.78 gal/ft 46.94 l/m											
	8	Grade	8	K55	L80	N80	C90	T95	P110	Q125	K55	L80	N80	C90	T95	P110	Q125			
	9	Collapse resistance (MPa)	9	14.0	16.4	16.4	16.9	17.0	17.1	17.1	17.7	21.3	21.3	22.4	22.9	24.0	24.3			
	10	Internal yield pressure (MPa)	10	24.3	35.3	35.3	39.7	41.9	48.5	55.2	27.2	39.6	39.6	44.6	47.0	54.5	61.9			
	11	Pipe body yield strength (1000 daN)	11	251	365	365	411	433	502	570	280	408	408	459	484	560	637			
Tensile strength (10 ³ daN)	12	Buttress Standard	12	336	377	390	407	428	504	555	375	421	436	454	478	563	620			
	13	Buttress Special Clearance	13	336	377	390	407	428	504	555	375	416	436	437	459	547	591			
	14	API STC	14	188	245	249	271	286	334	374	216	282	285	312	328	383	430			
	15	API LTC	15	218	282	286	312	328	383	430	250	323	328	358	377	440	493			
Connection efficiency	16	Grant Prideco TCH	16																	
	17	Grant Prideco STL	17																	
	18	Hydril LX	18																	
	19	Hydril 563	19	90.7					59.9											
	20	Hydril 511	20																	
	21	Hydril 521	21	66.7					70.0											
	22	Vallourec & Mannesmann New VAM	22	177.6					159.0											
	23	Vallourec & Mannesmann VAM ACE	23	173.9					155.6											
	24	Vallourec & Mannesmann VAM PRO	24	100.0					100.0											
	25	Vallourec & Mannesmann VAM TOP	25						102.1											
	26	Vallourec & Mannesmann FJL	26	53.5					58.4											
Connection characteristics	27	Buttress Standard	27	Make-up torque (daN.m)					OD (mm)	ID (mm)	Drift API (mm)	Make-up torque (daN.m)					OD (mm)	ID (mm)	Drift API (mm)	
	28	Buttress Special Clearance	28	K55	L80	C90/95	P110	Q125				K55	L80	C90/95	P110	Q125				
	29	API STC	29	574					269.9		222.6	659								
	30	API LTC	30	663					269.9		222.6	761	992	1148						
	31	Grant Prideco TCH	31		1593	1593	1593	1593	258.1	225.2	222.6		1708	1708	1708	1708	260.0	225.2	220.4	
	32	Grant Prideco STL	32									691	881	881	881	881	244.5	223.8	220.4	
	33	Hydril LX	33																	
	34	Hydril 563	34	1356	1356	1356	1356	1356	269.9	225.3	222.6	1464	1464	1464	1464	1464	269.9		220.4	
	35	Hydril 511	35									1180	1180	1180	1180	1180	244.5	223.4	220.4	
	36	Hydril 521	36	1247	1247	1247	1247	1247	251.0	224.7	222.6	1424	1424	1424	1424	1424	252.9	223.5	220.4	
	37	Vallourec & Mannesmann New VAM	37	1180	1376	1519	1620	1763	270.5		222.6	1424	1668	1817	1959	2156	270.5		220.4	
	38	Vallourec & Mannesmann VAM ACE	38	980	1180	1274	1376	1471	269.9		222.6	1180	1376	1566	1668	1864	269.9		220.4	
	39	Vallourec & Mannesmann VAM PRO	39						269.9		222.6						269.9		220.4	
	40	Vallourec & Mannesmann VAM TOP	40									1079	1274	1376	1566	1668	260.7		220.4	
	41	Vallourec & Mannesmann FJL	41		1519	1763	2061	2156	244.5	224.3	222.6		1566	1817	2061	2156	244.5	222.2	220.4	

(1) The closed-end displacement does not account for couplings. MPa × 145 = psi daN × 2.25 = lb daN.m × 7.38 = lb.ft mm × 0.0394 = in

GEOMETRICAL CHARACTERISTICS AND MECHANICAL PROPERTIES OF CASING (continued)

Pipe body	1	Nominal size (OD)	1	9.625 in					244.5 mm					9.625 in					244.5 mm				
	2	Nominal weight	2	43.50 lb/ft					63.5 daN/m					47.00 lb/ft					68.6 daN/m				
	3	Wall thickness	3	0.435 in					11.0 mm					0.472 in					12.0 mm				
	4	Inside diameter	4	8.755 in					222.4 mm					8.681 in					220.5 mm				
	5	Steel cross-section	5	12.56 in ²					8103 mm ²					13.57 in ²					8756 mm ²				
	6	Capacity	6	3.13 gal/ft					38.84 l/m					3.07 gal/ft					38.19 l/m				
	7	Displacement (1)	7	3.78 gal/ft					46.94 l/m					3.78 gal/ft					46.94 l/m				
	8	Grade	8	K55	L80	N80	C90	T95	P110	Q125	K55	L80	N80	C90	T95	P110	Q125						
	9	Collapse resistance (MPa)	9	22.4	26.3	26.3	27.6	28.4	30.5	31.9	26.8	32.8	32.8	34.4	35.1	36.5	38.8						
	10	Internal yield pressure (MPa)	10	30.0	43.6	43.6	49.1	51.8	60.0	68.2	32.5	47.3	47.3	53.3	56.2	65.1	74.0						
	11	Pipe body yield strength (1000 daN)	11	307	447	447	503	531	615	698	332	483	483	543	574	664	755						
Tensile strength (10 ³ daN)	12	Buttress Standard	12	411	462	478	498	524	617	679	445	499	516	538	566	667	734						
	13	Buttress Special Clearance	13	411	416	437	437	459	547	591	416	416	437	437	459	547	591						
	14	API STC	14	242	315	319	348	367	428	481	265	346	350	382	403	470	527						
	15	API LTC	15	279	362	367	400	422	492	552	306	397	403	439	463	540	605						
Connection efficiency	16	Grant Prideco TCII	16																				
	17	Grant Prideco STL	17													67.0							
	18	Hydril LX	18													74.1							
	19	Hydril 563	19													92.4							
	20	Hydril 511	20													62.5							
	21	Hydril 521	21													72.3							
	22	Vallourec & Mannesmann New VAM	22													145.0							
	23	Vallourec & Mannesmann VAM ACE	23													141.9							
	24	Vallourec & Mannesmann VAM PRO	24													100.0							
	25	Vallourec & Mannesmann VAM TOP	25													102.0							
	26	Vallourec & Mannesmann FJL	26													62.0							
Connection characteristics	27	Buttress Standard	27	Make-up torque (daN.m)					OD (mm)	ID (mm)	Drift API (mm)	Make-up torque (daN.m)					OD (mm)	ID (mm)	Drift API (mm)				
	28	Buttress Special Clearance	28	K55	LIN80	C90/95	P110	Q125				K55	LIN80	C90/95	P110	Q125							
	29	API STC	29																				
	30	API LTC	30		1110	1285	1498		269.9		218.4		1219	1410	1645	1844	269.9		216.5				
	31	Grant Prideco TCII	31		2054	2054	2054	2054	261.7	223.4	218.4		2373	2373	2373	2373	263.3	221.8	216.5				
	32	Grant Prideco STL	32	868	1098	1098	1098	1098	244.5	219.7	218.4	908	1234	1234	1234	1234	244.5	219.6	216.5				
	33	Hydril LX	33	1491	1830	2034	2237	2508	248.4	220.3	218.4	1627	2034	2305	2440	2644	248.5	218.5	216.5				
	34	Hydril 563	34	1613	1613	1613	1613	1613	269.9		218.4	1790	1790	1790	1790	1790	269.9		216.5				
	35	Hydril 511	35	1315	1315	1315	1315	1315	244.5	220.2	218.4	1627	1627	1627	1627	1627	244.5	217.7	216.5				
	36	Hydril 521	36	1586	1586	1586	1586	1586	254.6	220.5	218.4	1735	1735	1735	1735	1735	256.2	218.6	216.5				
	37	Vallourec & Mannesmann New VAM	37	1620	1912	2061	2156	2156	270.5		218.4	1668	1959	2156	2156	2156	270.5		216.5				
	38	Vallourec & Mannesmann VAM ACE	38	1471	1668	1864	1959	2156	269.9		218.4	1763	1959	2156	2156	2156	269.9		216.5				
	39	Vallourec & Mannesmann VAM PRO	39						269.9		218.4						269.9		216.5				
	40	Vallourec & Mannesmann VAM TOP	40	1471	1763	1959	2156	2352	262.5		218.4	1763	2156	2352	2746	2942	264.1		216.5				
	41	Vallourec & Mannesmann FJL	41		1620	1864	2061	2156	244.5	220.2	218.4		1668	1912	2156	2156	244.5	219.4	216.5				

(1) The closed-end displacement does not account for couplings. MPa × 145 = psi daN × 2.25 = lb daN.m × 7.38 = lb.ft mm × 0.0394 = in

GEOMETRICAL CHARACTERISTICS AND MECHANICAL PROPERTIES OF CASING (continued)

Pipe body	1	Nominal size (OD)	1	9.625 in					244.5 mm					9.625 in					244.5 mm				
	2	Nominal weight	2	53.50 lb/ft					78.1 daN/m					58.40 lb/ft					85.2 daN/m				
	3	Wall thickness	3	0.545 in					13.8 mm					0.595 in					15.1 mm				
	4	Inside diameter	4	8.535 in					216.8 mm					8.435 in					214.2 mm				
	5	Steel cross-section	5	15.55 in ²					10 030 mm ²					16.88 in ²					10 890 mm ²				
	6	Capacity	6	2.97 gal/ft					36.91 l/m					2.90 gal/ft					36.05 l/m				
	7	Displacement (1)	7	3.78 gal/ft					46.94 l/m					3.78 gal/ft					46.94 l/m				
Tensile strength (10 ³ daN)	8	Grade	8	K55	L80	N80	C90	T95	P110	Q125	K55	L80	N80	C90	T95	P110	Q125						
	9	Collapse resistance (MPa)	9	35.4	45.6	45.6	49.1	50.6	54.8	58.2	41.3	54.4	54.4	59.1	61.3	67.3	72.7						
	10	Internal yield pressure (MPa)	10	37.6	54.7	54.7	61.5	64.9	75.2	85.4	41.0	59.7	59.7	67.1	70.9	82.0	93.2						
	11	Pipe body yield strength (1000 daN)	11	380	553	553	622	657	761	864	413	601	601	676	713	826	939						
Connection efficiency	12	Buttress Standard	12	509	572	591	616	648	764	841	553	621	642	669	704	830	913						
	13	Buttress Special Clearance	13	416	416	437	437	459	547	591	416	416	437	437	459	547	591						
	14	API STC	14	311	405	411	448	473	551	618	342	446	452	493	520	606	680						
	15	API LTC	15	359	466	472	515	543	633	710	395	512	519	566	596	696	780						
Connection characteristics	16	Grant Prideco TCII	16																				
	17	Grant Prideco STL	17						62.9					65.0									
	18	Hydril LX	18						77.6					76.9									
	19	Hydril 563	19						93.9					91.2									
	20	Hydril 511	20																				
	21	Hydril 521	21						77.0														
	22	Vallourec & Mannesmann New VAM	22						117.1					107.9									
	23	Vallourec & Mannesmann VAM ACE	23						114.7					105.6									
	24	Vallourec & Mannesmann VAM PRO	24						100.0					100.0									
	25	Vallourec & Mannesmann VAM TOP	25						102.1					102.0									
	26	Vallourec & Mannesmann FJL	26						65.1					68.1									
Connection characteristics	27	Buttress Standard	27	Make-up torque (daN.m)					OD (mm)	ID (mm)	Drift API (mm)	Make-up torque (daN.m)					OD (mm)	ID (mm)	Drift API (mm)				
	28	Buttress Special Clearance	28						269.9		212.8						269.9		210.3				
	29	API STC	29						257.2		212.8						257.2		210.3				
	30	API LTC	30																				
	31	Grant Prideco TCII	31		1430	1654	1928	2163	269.9		212.8												
	32	Grant Prideco STL	32	1098	1383	1383	1383	1383	244.5	217.6	212.8	1112	1410	1410	1410	1410	244.5	215.2	210.3				
	33	Hydril LX	33	1763	2169	2373	2644	2847	249.5	216.8	212.8	1966	2373	2576	2847	3118	249.7	214.5	210.3				
	34	Hydril 563	34	2102	2102	2102	2102	2102	269.9		212.8	3064	3064	3064	3064	3064	269.9		210.3				
	35	Hydril 511	35																				
	36	Hydril 521	36	2020	2020	2020	2020	2020	259.2	216.8	212.8												
	37	Vallourec & Mannesmann New VAM	37	1817	2156	2156	2156	2156	270.5		212.8	1912	2156	2156	2156	2156	270.5		210.3				
	38	Vallourec & Mannesmann VAM ACE	38	1966	2156	2156	2156	2156	269.9		212.8	2156	2156	2156	2156	2156	269.9		210.3				
	39	Vallourec & Mannesmann VAM PRO	39						269.9					269.9									
	40	Vallourec & Mannesmann VAM TOP	40	2454	3139	3139	3139	3139	267.2		212.8	2942	3139	3139	3139	3139	269.2		210.3				
	41	Vallourec & Mannesmann FJL	41		1763	1959	2156	2156	244.5	217.6	212.8		1817	2061	2156	2156	244.5	212.4	210.3				

(1) The closed-end displacement does not account for couplings. MPa × 145 = psi daN × 2.25 = lb daN.m × 7.38 = lb.ft mm × 0.0394 = in

GEOMETRICAL CHARACTERISTICS AND MECHANICAL PROPERTIES OF CASING (continued)

Pipe body	1	Nominal size (OD)	1	9.625 in					244.5 mm					9.625 in					244.5 mm					
	2	Nominal weight	2	59.40 lb/ft					86.7 daN/m					61.10 lb/ft					89.2 daN/m					
	3	Wall thickness	3	0.609 in					15.5 mm					0.625 in					15.9 mm					
	4	Inside diameter	4	8.407 in					213.5 mm					8.375 in					212.7 mm					
	5	Steel cross-section	5	17.25 in ²					11 129 mm ²					17.67 in ²					11 401 mm ²					
	6	Capacity	6	2.88 gal/ft					35.81 l/m					2.86 gal/ft					35.54 l/m					
	7	Displacement (1)	7	3.78 gal/ft					46.94 l/m					3.78 gal/ft					46.94 l/m					
	8	Grade	8	K55	L80	N80	C90	T95	P110	Q125	K55	L80	N80	C90	T95	P110	Q125	K55	L80	N80	C90	T95	P110	Q125
	9	Collapse resistance (MPa)	9	42.9	56.9	56.9	61.9	64.2	70.9	76.7	44.8	59.7	59.7	65.1	67.6	74.9	81.4	44.8	59.7	59.7	65.1	67.6	74.9	81.4
	10	Internal yield pressure (MPa)	10	42.0	61.1	61.1	68.7	72.5	84.0	95.4	43.1	62.7	62.7	70.5	74.4	86.2	97.9	43.1	62.7	62.7	70.5	74.4	86.2	97.9
	11	Pipe body yield strength (1000 daN)	11	422	614	614	691	729	844	959	432	629	629	707	747	865	983	432	629	629	707	747	865	983
Tensile strength (10 ³ daN)	12	Buttress Standard	12	565	634	656	684	720	848	933	579	650	672	701	737	869	956	579	650	672	701	737	869	956
	13	Buttress Special Clearance	13	416	416	437	437	459	547	591	416	416	437	437	459	547	591	416	416	437	437	459	547	591
	14	API STC	14	351	457	463	505	533	621	697	360	469	476	519	548	638	716	360	469	476	519	548	638	716
	15	API LTC	15	405	525	532	580	611	713	800	416	539	547	596	629	733	822	416	539	547	596	629	733	822
	16	Grant Prideco TCII	16																					
Connection efficiency	17	Grant Prideco STL	17																					
	18	Hydril LX	18																					
	19	Hydril 563	19						91.4					91.6										
	20	Hydril 511	20																					
	21	Hydril 521	21																					
	22	Vallourec & Mannesmann New VAM	22						105.6					103.1										
	23	Vallourec & Mannesmann VAM ACE	23						103.3					102.0										
	24	Vallourec & Mannesmann VAM PRO	24						100.0					100.0										
	25	Vallourec & Mannesmann VAM TOP	25																					
	26	Vallourec & Mannesmann FJL	26						66.7					65.1										
	Connection characteristics	27	Buttress Standard	27	Make-up torque (daN.m)					OD (mm)	ID (mm)	Drift API (mm)	Make-up torque (daN.m)					OD (mm)	ID (mm)	Drift API (mm)				
28		Buttress Special Clearance	28	K55	LN80	C90/95	P110	Q125	K55				LN80	C90/95	P110	Q125								
29		API STC	29																					
30		API LTC	30																					
31		Grant Prideco TCII	31																					
32		Grant Prideco STL	32																					
33		Hydril LX	33																					
34		Hydril 563	34	3146	3146	3146	3146	3146	269.9		209.6	3254	3254	3254	3254	3254	269.9		208.8					
35		Hydril 511	35																					
36		Hydril 521	36																					
37		Vallourec & Mannesmann New VAM	37	1966	2156	2156	2156	2156	270.5		209.6	1966	2156	2156	2156	2156	270.5		208.8					
38		Vallourec & Mannesmann VAM ACE	38	2156	2156	2156	2156	2156	269.9		209.6	2156	2156	2156	2156	2156	270.2		208.8					
39		Vallourec & Mannesmann VAM PRO	39						269.9		209.6						269.9		208.8					
40		Vallourec & Mannesmann VAM TOP	40																					
41		Vallourec & Mannesmann FJL	41		1817	2061	2156	2156	244.5	212.4	209.6		1864	2061	2156	2156	244.5	212.4	208.8					

(1) The closed-end displacement does not account for couplings. MPa × 145 = psi daN × 2.25 = lb daN.m × 7.38 = lb.ft mm × 0.0394 = in

GEOMETRICAL CHARACTERISTICS AND MECHANICAL PROPERTIES OF CASING (continued)

Pipe body	1	Nominal size (OD)	1	9.875 in				250.8 mm				10.750 in				273.0 mm						
	2	Nominal weight	2	62.80 lb/ft				91.6 daN/m				40.50 lb/ft				59.1 daN/m						
	3	Wall thickness	3	0.625 in				15.9 mm				0.350 in				8.9 mm						
	4	Inside diameter	4	8.625 in				219.1 mm				10.050 in				255.3 mm						
	5	Steel cross-section	5	18.16 in ²				11 718 mm ²				11.44 in ²				7378 mm ²						
	6	Capacity	6	3.04 gal/ft				37.69 l/m				4.12 gal/ft				51.18 l/m						
	7	Displacement (1)	7	3.98 gal/ft				49.41 l/m				4.72 gal/ft				58.56 l/m						
	8	Grade	8	K55	L80	N80	C90	T95	P110	Q125	K55	L80	N80	C90	T95	P110	Q125					
	9	Collapse resistance (MPa)	9	43.0	56.9	56.9	61.9	64.3	70.9	76.8	10.9	11.9	11.9	11.9	11.9	11.9	11.9					
	10	Internal yield pressure (MPa)	10	42.0	61.1	61.1	68.7	72.5	84.0	95.5	21.6	31.4	31.4	35.4	37.3	43.2	49.1					
	11	Pipe body yield strength (1000 daN)	11	444	646	646	727	768	889	1010	280	407	407	458	483	560	636					
Tensile strength (10 ³ daN)	12	Buttress Standard	12													364	416	429	449	473	557	614
	13	Buttress Special Clearance	13																			
	14	API STC	14													200	262	266	291	306	357	401
	15	API LTC	15																			
Connection efficiency	16	Grant Prideco TCII	16																			
	17	Grant Prideco STL	17													70.3						
	18	Hydril LX	18													79.1						
	19	Hydril 563	19													91.6						
	20	Hydril 511	20													90.7						
	21	Hydril 521	21													63.2						
	22	Vallourec & Mannesmann New VAM	22													176.6						
	23	Vallourec & Mannesmann VAM ACE	23													173.7						
	24	Vallourec & Mannesmann VAM PRO	24													90.0						
	25	Vallourec & Mannesmann VAM TOP	25													102.0						
	26	Vallourec & Mannesmann FJL	26													68.1						
Connection characteristics	27	Buttress Standard	27	Make-up torque (daN.m)					OD (mm)	ID (mm)	Drift API (mm)	Make-up torque (daN.m)					OD (mm)	ID (mm)	Drift API (mm)			
	28	Buttress Special Clearance	28	K55	LN80	C90/95	P110	Q125				K55	LN80	C90/95	P110	Q125						
	29	API STC	29									610										
	30	API LTC	30																			
	31	Grant Prideco TCII	31		3925	3925	3925	3925	275.8	221.3	215.1		1830	1830	1830	1830	286.6	253.5	251.3			
	32	Grant Prideco STL	32	1302	1661	1661	1661	1661	250.8	216.3	215.1	691	881	881	881	881	273.0	254.5	251.3			
	33	Hydril LX	33	2169	2576	2915	3186	3457	255.7	216.8	215.1											
	34	Hydril 563	34	3254	3254	3254	3254	3254	269.9		215.1	1654	1654	1654	1654	1654	298.4	254.0	251.3			
	35	Hydril 511	35																			
	36	Hydril 521	36									1356	1356	1356	1356	1356	275.9	253.4	251.3			
	37	Vallourec & Mannesmann New VAM	37									1274	1519	1668	1817	1959	299.0		251.3			
	38	Vallourec & Mannesmann VAM ACE	38	2752	3186	3186	3186	3186	276.8		215.1	1079	1274	1471	1566	1668	298.4		251.3			
	39	Vallourec & Mannesmann VAM PRO	39																			
	40	Vallourec & Mannesmann VAM TOP	40	3139	3139	3139	3139	3139	277.0		215.1											
	41	Vallourec & Mannesmann FJL	41		1959	2156	2156	2156	250.8	217.9	215.1		1959	2156	2156	2156	273.0	253.2	251.3			

(1) The closed-end displacement does not account for couplings. MPa × 145 = psi daN × 2.25 = lb daN.m × 7.38 = lb.ft mm × 0.0394 = in

GEOMETRICAL CHARACTERISTICS AND MECHANICAL PROPERTIES OF CASING (continued)

Pipe body	1	Nominal size (OD)	1	10.750 in					273.0 mm					10.750 in					273.0 mm				
	2	Nominal weight	2	45.50 lb/ft					66.4 daN/m					51.00 lb/ft					74.4 daN/m				
	3	Wall thickness	3	0.400 in					10.2 mm					0.450 in					11.4 mm				
	4	Inside diameter	4	9.950 in					252.7 mm					9.850 in					250.2 mm				
	5	Steel cross-section	5	13.01 in ²					8391 mm ²					14.56 in ²					9394 mm ²				
	6	Capacity	6	4.04 gal/ft					50.17 l/m					3.96 gal/ft					49.16 l/m				
	7	Displacement (1)	7	4.72 gal/ft					58.56 l/m					4.72 gal/ft					58.56 l/m				
	8	Grade	8	K55	L80	N80	C90	T95	P110	Q125	K55	L80	N80	C90	T95	P110	Q125						
Tensile strength (10 ³ daN)	9	Collapse resistance (MPa)	9	14.4	17.1	17.1	17.6	17.8	18.0	18.0	18.7	22.2	22.2	23.5	24.0	25.2	25.8						
	10	Internal yield pressure (MPa)	10	24.7	35.9	35.9	40.4	42.7	49.4	56.1	27.8	40.4	40.4	45.5	48.0	55.6	63.1						
	11	Pipe body yield strength (1000 daN)	11	318	463	463	521	550	636	723	356	518	518	583	615	712	810						
Tensile strength (10 ³ daN)	12	Buttress Standard	12	414	473	488	511	538	633	698	464	529	546	572	602	709	782						
	13	Buttress Special Clearance	13																				
	14	API STC	14	235	308	312	341	359	419	471	269	353	358	391	412	480	539						
	15	API LTC	15																				
Connection efficiency	16	Grant Prideco TCII	16																				
	17	Grant Prideco STL	17				59.9							67.5									
	18	Hydril LX	18											73.9									
	19	Hydril 563	19				91.8							92.7									
	20	Hydril 511	20				59.0							62.9									
	21	Hydril 521	21				66.5							70.4									
	22	Vallourec & Mannesmann New VAM	22				155.2							138.6									
	23	Vallourec & Mannesmann VAM ACE	23				152.7							136.4									
	24	Vallourec & Mannesmann VAM PRO	24																				
	25	Vallourec & Mannesmann VAM TOP	25				102.1							102.1									
26	Vallourec & Mannesmann FJL	26				58.1							62.6										
Connection characteristics	27	Buttress Standard	27	Make-up torque (daN.m)					OD (mm)	ID (mm)	Drift API (mm)	Make-up torque (daN.m)					OD (mm)	ID (mm)	Drift API (mm)				
	28	Buttress Special Clearance	28						298.4		248.8						298.4		246.2				
	29	API STC	29	716						298.5		248.8	822	1083	1257	1463		298.5	246.2				
	30	API LTC	30																				
	31	Grant Prideco TCII	31		1993	1993	1993	1993	288.8	253.5	248.8							291.0	251.2	246.2			
	32	Grant Prideco STL	32	786	1003	1003	1003	1003	273.0	252.7	248.8	1017	1274	1274	1274	1274	273.0	248.0	246.2				
	33	Hydril LX	33									1830	2305	2508	2847	3051	277.2	248.2	246.2				
	34	Hydril 563	34	1830	1830	1830	1830	1830	298.4		248.8	2102	2102	2102	2102	2102	298.4		246.2				
	35	Hydril 511	35	1329	1329	1329	1329	1329	273.0	252.0	248.8	1722	1722	1722	1722	1722	273.0	247.4	246.2				
	36	Hydril 521	36	1600	1600	1600	1600	1600	278.1	252.1	248.8	1844	1844	1844	1844	1844	280.3	248.3	246.2				
	37	Vallourec & Mannesmann New VAM	37	1566	1912	2061	2156	2156	299.0		248.8	1668	1959	2156	2156	2156	299.0		246.2				
	38	Vallourec & Mannesmann VAM ACE	38	1376	1566	1763	1959	2156	298.4		248.8	1668	1840	2061	2156	2156	298.4		246.2				
	39	Vallourec & Mannesmann VAM PRO	39																				
	40	Vallourec & Mannesmann VAM TOP	40	1180	1471	1566	1763	1959	289.6		248.8	1668	2156	2352	2644	2942	291.8		246.2				
	41	Vallourec & Mannesmann FJL	41		1959	2156	2156	2156	273.0	250.6	248.8		1959	2156	2156	2156	273.0	248.1	246.2				

(1) The closed-end displacement does not account for couplings. MPa × 145 = psi daN × 2.25 = lb daN.m × 7.38 = lb.ft mm × 0.0394 = in

GEOMETRICAL CHARACTERISTICS AND MECHANICAL PROPERTIES OF CASING (continued)

			10.750 in 273.0 mm						10.750 in 273.0 mm										
			273.0 mm						273.0 mm										
Pipe body	1	Nominal size (OD)	10.750 in 273.0 mm						10.750 in 273.0 mm										
	2	Nominal weight	55.50 lb/ft 81.0 daN/m						60.70 lb/ft 88.6 daN/m										
	3	Wall thickness	0.495 in 12.6 mm						0.545 in 13.8 mm										
	4	Inside diameter	9.760 in 247.9 mm						9.660 in 245.4 mm										
	5	Steel cross-section	15.95 in ² 10 289 mm ²						17.47 in ² 11 273 mm ²										
	6	Capacity	3.89 gal/ft 48.27 l/m						3.81 gal/ft 47.28 l/m										
	7	Displacement (1)	4.72 gal/ft 58.56 l/m						4.72 gal/ft 58.56 l/m										
	8	Grade	8	K55	L80	N80	C90	T95	P110	Q125	K55	L80	N80	C90	T95	P110	Q125		
9	Collapse resistance (MPa)	9	23.4	27.7	27.7	28.7	29.6	31.8	33.4	28.7	35.6	35.6	37.6	38.5	40.5	41.9			
10	Internal yield pressure (MPa)	10	30.6	44.4	44.4	50.0	52.8	61.1	69.4	33.6	48.9	48.9	55.1	58.1	67.3	76.5			
11	Pipe body yield strength (1000 daN)	11	390	568	568	638	674	780	887	427	622	622	700	738	855	972			
Tensile strength (10 ³ daN)	12	Buttress Standard	12	508	580	598	627	660	776	856	557	635	655	687	723	851	938		
	13	Buttress Special Clearance	13																
	14	API STC	14	300	393	398	435	459	535	601	334	437	443	484	511	595	668		
	15	API LTC	15																
Connection efficiency	16	Grant Prideco TCII	16																
	17	Grant Prideco STL	17				59.9							69.7					
	18	HydriL LX	18				75.8							76.7					
	19	HydriL 563	19				90.5							91.3					
	20	HydriL 511	20				60.4							64.4					
	21	HydriL 521	21				71.9							74.0					
	22	Vallourec & Mannesmann New VAM	22				126.6							115.6					
	23	Vallourec & Mannesmann VAM ACE	23				124.6							113.7					
	24	Vallourec & Mannesmann VAM PRO	24																
	25	Vallourec & Mannesmann VAM TOP	25				101.9							102.1					
	26	Vallourec & Mannesmann FJL	26				65.2							65.6					
Connection characteristics	27	Buttress Standard	27																
	28	Buttress Special Clearance	28																
	29	API STC	29		1206	1399	1630								1813	2036			
	30	API LTC	30																
	31	Grant Prideco TCII	31		2922	2922	2922	2922	293.0	249.2	243.9		3464	3464	3464	3464	295.1	247.0	241.4
	32	Grant Prideco STL	32		976	1234	1234	1234	273.0	249.3	243.9	1070	1349	1349	1349	1349	273.0	243.5	241.4
	33	HydriL LX	33	2034	2440	2779	2983	3322	277.4	245.9	243.9	2237	2779	3118	3457	3661	277.6	243.3	241.4
	34	HydriL 563	34	3091	3091	3091	3091	3091	298.4	246.6	243.9	3390	3390	3390	3390	3390	298.4		241.4
	35	HydriL 511	35	1871	1871	1871	1871	1871	273.0	245.7	243.9	2495	2495	2495	2495	2495	273.0	242.6	241.4
	36	HydriL 521	36	2400	2400	2400	2400	2400	279.7	246.0	243.9	2698	2698	2698	2698	2698	281.8	243.5	241.4
	37	Vallourec & Mannesmann New VAM	37	1763	2061	2156	2156	2156	299.0		243.9	1864	2156	2156	2156	2156	299.0		241.4
	38	Vallourec & Mannesmann VAM ACE	38	1959	2156	2156	2156	2156	298.4		243.9	2156	2156	2156	2156	2156	298.4		241.4
	39	Vallourec & Mannesmann VAM PRO	39																
	40	Vallourec & Mannesmann VAM TOP	40	2156	2746	3139	3139	3139	293.8		243.9	2746	3139	3139	3139	3139	296.0		241.4
	41	Vallourec & Mannesmann FJL	41		2061	2156	2156	2156	273.0	246.0	243.9		2156	2156	2156	2156	273.0	243.5	241.4

(1) The closed-end displacement does not account for couplings. MPa × 145 = psi daN × 2.25 = lb daN.m × 7.38 = lb.ft mm × 0.0394 = in

GEOMETRICAL CHARACTERISTICS AND MECHANICAL PROPERTIES OF CASING (continued)

	Pipe body	1	11.750 in 273.0 mm							11.750 in 298.4 mm								
			65.70 lb/ft 95.9 daN/m							47.00 lb/ft 68.6 daN/m								
	Pipe body	3	0.595 in 15.1 mm		0.375 in 9.5 mm													
		4	9.560 in 242.8 mm		11.000 in 279.4 mm													
	Pipe body	5	18.98 in ² 12 247 mm ²		13.40 in ² 8646 mm ²													
		6	3.73 gal/ft 46.31 l/m		4.94 gal/ft 61.31 l/m													
	Pipe body	7	4.72 gal/ft 58.56 l/m		5.63 gal/ft 69.96 l/m													
		8	K55 L80 N80 C90 T95 P110 Q125							K55 L80 N80 C90 T95 P110 Q125								
	Pipe body	9	33.9	43.5	43.5	46.6	48.0	51.7	54.6	10.4	11.2	11.2	11.2	11.2	11.2	11.2		
		10	36.7	53.4	53.4	60.1	63.4	73.5	83.5	21.2	30.8	30.8	34.7	36.6	42.4	48.1		
	Pipe body	11	464	675	675	760	802	929	1055	328	477	477	536	566	656	745		
		12	605	690	712	746	785	924	1019	416	482	496	523	550	647	715		
	Tensile strength (10 ³ daN)	13																
		14	367	481	487	533	562	655	735	226	298	302	330	348	406	456		
	Tensile strength (10 ³ daN)	15																
		16																
	Connection efficiency	17																
		18																
	Connection efficiency	19																
		20																
	Connection efficiency	21																
		22																
	Connection efficiency	23																
		24																
	Connection efficiency	25																
		26																
	Connection characteristics	27	Make-up torque (daN.m)					OD (mm)	ID (mm)	Drift API (mm)	Make-up torque (daN.m)					OD (mm)	ID (mm)	Drift API (mm)
		28	K55	L80	C90/95	P110	Q125				K55	L80	C90/95	P110	Q125			
	Connection characteristics	29				1994	2240	298.5	238.9	690					323.9		275.4	
		30																275.4
	Connection characteristics	31		4013	4013	4013	4013	297.2	244.8	238.9	2332	2332	2332	2332	313.0	277.2	275.4	
		32	1152	1458	1458	1458	1458	273.0	245.8	238.9								
	Connection characteristics	33	2373	2915	3254	3525	3796	278.5	242.4	238.9								
		34	3661	3661	3661	3661	3661	298.4		238.9	1763	1763	1763	1763	323.9		275.4	
	Connection characteristics	35	2495	2495	2495	2495	2495	273.0	242.5	238.9								
		36	2996	2996	2996	2996	2996	283.9	242.6	238.9	1546	1546	1546	1546	302.1	277.5	275.4	
	Connection characteristics	37	1959	2156	2156	2156	2156	299.0		238.9	1424	1715	1912	2061	2156	324.4	275.4	
		38	2156	2156	2156	2156	2156	298.4		238.9	1471	1668	1763	1959	2156	323.9	275.4	
	Connection characteristics	39																
		40	3139	3139	3139	3139	3139	298.0		238.9								
	Connection characteristics	41		2156	2156	2156	2156	273.0	241.0	238.9		2156	2156	2156	2156	298.4	278.4	275.4

(1) The closed-end displacement does not account for couplings. MPa × 145 = psi daN × 2.25 = lb daN.m × 7.38 = lb.ft mm × 0.0394 = in

GEOMETRICAL CHARACTERISTICS AND MECHANICAL PROPERTIES OF CASING (continued)

Pipe body	1	Nominal size (OD)	1	11.750 in					298.4 mm					11.750 in					298.4 mm				
	2	Nominal weight	2	54.00 lb/ft					78.8 daN/m					60.00 lb/ft					87.6 daN/m				
	3	Wall thickness	3	0.435 in					11.0 mm					0.489 in					12.4 mm				
	4	Inside diameter	4	10.880 in					276.4 mm					10.772 in					273.6 mm				
	5	Steel cross-section	5	15.46 in ²					9976 mm ²					17.30 in ²					11 161 mm ²				
	6	Capacity	6	4.83 gal/ft					59.98 l/m					4.73 gal/ft					58.80 l/m				
	7	Displacement (1)	7	5.63 gal/ft					69.96 l/m					5.63 gal/ft					69.96 l/m				
	8	Grade	8	K55	L80	N80	C90	T95	P110	Q125	K55	L80	N80	C90	T95	P110	Q125						
	9	Collapse resistance (MPa)	9	14.3	16.9	16.9	17.4	17.6	17.7	17.7	18.4	21.9	21.9	23.2	23.7	24.9	25.4						
	10	Internal yield pressure (MPa)	10	24.6	35.7	35.7	40.2	42.4	49.1	55.8	27.6	40.2	40.2	45.2	47.7	55.2	62.8						
	11	Pipe body yield strength (1000 daN)	11	378	550	550	619	653	757	860	423	616	616	693	731	846	962						
Tensile strength (10 ³ daN)	12	Buttress Standard	12	480	556	573	603	635	746	825	537	622	641	675	710	835	923						
	13	Buttress Special Clearance	13																				
	14	API STC	14	270	355	359	394	415	484	543	308	406	411	450	474	553	621						
	15	API LTC	15																				
Connection efficiency	16	Grant Prideco TCII	16														59.9						
	17	Grant Prideco STL	17														72.5						
	18	Hydril LX	18														90.4						
	19	Hydril 563	19				92.5										60.7						
	20	Hydril 511	20														70.6						
	21	Hydril 521	21					68.5									127.1						
	22	Vallourec & Mannesmann New VAM	22					142.2									125.1						
	23	Vallourec & Mannesmann VAM ACE	23					139.9															
	24	Vallourec & Mannesmann VAM PRO	24																				
	25	Vallourec & Mannesmann VAM TOP	25					102.1									102.0						
	26	Vallourec & Mannesmann FJL	26					59.7									63.5						
Connection characteristics	27	Buttress Standard	27	Make-up torque (daN.m)					OD (mm)	ID (mm)	Drift API (mm)	Make-up torque (daN.m)					OD (mm)	ID (mm)	Drift API (mm)				
	28	Buttress Special Clearance	28	K55	L80	C90/95	P110	Q125				K55	L80	C90/95	P110	Q125							
	29	API STC	29	822					323.9		272.4	940	1245	1445	1684	1891	323.9		269.6				
	30	API LTC	30																				
	31	Grant Prideco TCII	31		2569	2569	2569	2569	315.7	277.2	272.4		3173	3173	3173	3173	318.1	274.8	269.6				
	32	Grant Prideco STL	32									1058	1329	1329	1329	1329	298.4	275.0	269.6				
	33	Hydril LX	33									2305	2915	3254	3593	4000	303.0	271.6	269.6				
	34	Hydril 563	34	2088	2088	2088	2088	2088	323.9		272.4	3051	3051	3051	3051	3051	323.9	272.3	269.6				
	35	Hydril 511	35									2413	2413	2413	2413	2413	298.4	271.1	269.6				
	36	Hydril 521	36	1844	1844	1844	1844	1844	304.7	271.4	272.4	2427	2427	2427	2427	2427	303.0	271.4	269.6				
	37	Vallourec & Mannesmann New VAM	37	1959	2156	2156	2156	2156	324.4		272.4	2061	2156	2156	2156	2156	324.4		269.6				
	38	Vallourec & Mannesmann VAM ACE	38	1864	2061	2156	2156	2156	323.9		272.4	2156	2156	2156	2156	2156	323.9		269.6				
	39	Vallourec & Mannesmann VAM PRO	39																				
	40	Vallourec & Mannesmann VAM TOP	40	1668	2061	2257	2549	2847	316.6		272.4	2257	2942	3139	3139	3139	318.9		269.6				
	41	Vallourec & Mannesmann FJL	41		2156	2156	2156	2156	298.4	275.2	272.4		2156	2156	2156	2156	298.4	272.2	269.6				

(1) The closed-end displacement does not account for couplings. MPa × 145 = psi daN × 2.25 = lb daN.m × 7.38 = lb.ft mm × 0.0394 = in

GEOMETRICAL CHARACTERISTICS AND MECHANICAL PROPERTIES OF CASING (continued)

Pipe body	1	Nominal size (OD)	1	11.750 in					298.4 mm					11.750 in					298.4 mm				
	2	Nominal weight	2	65.00 lb/ft					94.9 daN/m					71.00 lb/ft					103.6 daN/m				
	3	Wall thickness	3	0.534 in					13.6 mm					0.582 in					14.8 mm				
	4	Inside diameter	4	10.682 in					271.3 mm					10.586 in					268.9 mm				
	5	Steel cross-section	5	18.82 in ²					12 139 mm ²					20.42 in ²					13 174 mm ²				
	6	Capacity	6	4.66 gal/ft					57.82 l/m					4.57 gal/ft					56.78 l/m				
	7	Displacement (1)	7	5.63 gal/ft					69.96 l/m					5.63 gal/ft					69.96 l/m				
	8	Grade	8	K55	L80	N80	C90	T95	P110	Q125	K55	L80	N80	C90	T95	P110	Q125						
	9	Collapse resistance (MPa)	9	22.7	26.7	26.7	28.0	28.8	30.9	32.3	27.4	33.6	33.6	35.4	36.1	37.7	39.7						
	10	Internal yield pressure (MPa)	10	30.2	43.9	43.9	49.4	52.1	60.3	68.5	32.9	47.8	47.8	53.8	56.8	65.7	74.7						
	11	Pipe body yield strength (1000 daN)	11	460	670	670	753	795	921	1046	500	727	727	817	863	999	1135						
Tensile strength (10 ³ daN)	12	Buttress Standard	12	584	677	697	734	772	908	1004	634	734	756	796	838	985	1089						
	13	Buttress Special Clearance	13																				
	14	API STC	14	340	448	453	496	523	610	685	374	492	498	546	575	670	753						
	15	API LTC	15																				
Connection efficiency	16	Grant Prideco TCII	16																				
	17	Grant Prideco STL	17				58.8							59.9									
	18	Hydril LX	18				74.4							76.7									
	19	Hydril 563	19				91.2							91.9									
	20	Hydril 511	20				55.8																
	21	Hydril 521	21				70.1							74.6									
	22	Vallourec & Mannesmann New VAM	22				116.9																
	23	Vallourec & Mannesmann VAM ACE	23				115.0																
	24	Vallourec & Mannesmann VAM PRO	24																				
	25	Vallourec & Mannesmann VAM TOP	25					102.1															
	26	Vallourec & Mannesmann FJL	26					64.6															
Connection characteristics				Make-up torque (daN.m)					OD (mm)	ID (mm)	Drift API (mm)	Make-up torque (daN.m)					OD (mm)	ID (mm)	Drift API (mm)				
				K55	L80	C90/95	P110	Q125				K55	L80	C90/95	P110	Q125							
	27	Buttress Standard	27						323.9		267.4						323.9		264.9				
	28	Buttress Special Clearance	28																				
	29	API STC	29																				
	30	API LTC	30																				
	31	Grant Prideco TCII	31		3701	3701	3701	3701	320.0	272.8	267.4		4291	4291	4291	4291	322.1	270.7	264.9				
	32	Grant Prideco STL	32	1125	1424	1424	1424	1424	298.4	271.6	267.4	1251	1566	1566	1566	1566	298.4	271.8	264.9				
	33	Hydril LX	33	2373	2983	3322	3661	4000	303.9	271.0	267.4	2915	3457	3796	4135	4474	304.2	266.8	264.9				
	34	Hydril 563	34	3254	3254	3254	3254	3254	323.9		267.4	3661	3661	3661	3661	3661	323.9		264.9				
	35	Hydril 511	35	2413	2413	2413	2413	2413	298.4	271.1	267.4												
	36	Hydril 521	36	2657	2657	2657	2657	2657	303.9	271.2	267.4	3037	3037	3037	3037	3037	308.0	266.7	264.9				
	37	Vallourec & Mannesmann New VAM	37	2156	2156	2156	2156	2156	324.4		267.4												
	38	Vallourec & Mannesmann VAM ACE	38	2156	2156	2156	2156	2156	323.9		267.4												
	39	Vallourec & Mannesmann VAM PRO	39																				
40	Vallourec & Mannesmann VAM TOP	40	2847	3139	3139	3139	3139	321.0		267.4													
41	Vallourec & Mannesmann FJL	41		2156	2156	2156	2156	298.4	271.8	267.4													

(1) The closed-end displacement does not account for couplings. MPa × 145 = psi daN × 2.25 = lb daN.m × 7.38 = lb.ft mm × 0.0394 = in

GEOMETRICAL CHARACTERISTICS AND MECHANICAL PROPERTIES OF CASING (continued)

Pipe body	1	Nominal size (OD)	1	13.375 in					339.7 mm					13.375 in				339.7 mm						
	2	Nominal weight	2	54.50 lb/ft					79.5 daN/m					61.00 lb/ft				89.0 daN/m						
	3	Wall thickness	3	0.380 in					9.7 mm					0.430 in				10.9 mm						
	4	Inside diameter	4	12.615 in					320.4 mm					12.515 in				317.9 mm						
	5	Steel cross-section	5	15.51 in ²					10 009 mm ²					17.49 in ²				11 282 mm ²						
	6	Capacity	6	6.49 gal/ft					80.64 l/m					6.39 gal/ft				79.36 l/m						
	7	Displacement (1)	7	7.30 gal/ft					90.65 l/m					7.30 gal/ft				90.65 l/m						
	8	Grade	8	K55	L80	N80	C90	T95	P110	Q125	K55	L80	N80	C90	T95	P110	Q125	K55	L80	N80	C90	T95	P110	Q125
	9	Collapse resistance (MPa)	9	7.8	7.9	7.9	7.9	7.9	7.9	7.9	10.6	11.5	11.5	11.5	11.5	11.5	11.5	21.3	31.0	31.0	34.9	36.9	42.7	48.5
	10	Internal yield pressure (MPa)	10	18.9	27.4	27.4	30.9	32.6	37.7	42.9	21.3	31.0	31.0	34.9	36.9	42.7	48.5	42.8	62.2	62.2	70.0	73.9	85.6	97.2
	11	Pipe body yield strength (1000 daN)	11	380	552	552	621	656	759	863	428	622	622	700	739	856	972	428	622	622	700	739	856	972
Tensile strength (10 ³ daN)	12	Buttress Standard	12	462	548	563	597	629	738	818	520	618	634	673	709	832	923	520	618	634	673	709	832	923
	13	Buttress Special Clearance	13																					
	14	API STC	14	243	322	326	358	377	439	494	282	373	377	414	437	509	572	282	373	377	414	437	509	572
	15	API LTC	15																					
Connection efficiency	16	Grant Prideco TCII	16																					
	17	Grant Prideco STL	17																					
	18	Hydril LX	18																					
	19	Hydril 563	19				90.3																	
	20	Hydril 511	20																					
	21	Hydril 521	21					61.0																
	22	Vallourec & Mannesmann New VAM	22					160.4																
	23	Vallourec & Mannesmann VAM ACE	23					158.0																
	24	Vallourec & Mannesmann VAM PRO	24																					
	25	Vallourec & Mannesmann VAM TOP	25																					
	26	Vallourec & Mannesmann FJL	26																					
Connection characteristics	27	Buttress Standard	27																					
	28	Buttress Special Clearance	28																					
	29	API STC	29	742																				
	30	API LTC	30																					
	31	Grant Prideco TCII	31		2657	2657	2657	2657	354.3	318.6	316.5													
	32	Grant Prideco STL	32									1058	1349	1349	1349	1349	339.7	318.6	313.9					
	33	Hydril LX	33																					
	34	Hydril 563	34	2359	2359	2359	2359	2359	365.1	318.5	316.5	2712	2712	2712	2712	2712	365.1	316.0	313.9					
	35	Hydril 511	35																					
	36	Hydril 521	36	2061	2061	2061	2061	2061	343.7	318.5	316.5	2386	2386	2386	2386	2386	320.5	316.0	313.9					
	37	Vallourec & Mannesmann New VAM	37	1566	1959	2156	2156	2156	365.7		316.5	2061	2156	2156	2156	2156	365.7							
	38	Vallourec & Mannesmann VAM ACE	38	1668	1959	2156	2156	2156	365.1		316.5	2061	2156	2156	2156	2156	365.1							
	39	Vallourec & Mannesmann VAM PRO	39																					
	40	Vallourec & Mannesmann VAM TOP	40									1763	2257	2549	2847	3139	357.8							
	41	Vallourec & Mannesmann FJL	41																					
				Make-up torque (daN.m)									Make-up torque (daN.m)											
				K55	LN80	C90/95	P110	Q125	OD (mm)	ID (mm)	Drift API (mm)	K55	LN80	C90/95	P110	Q125	OD (mm)	ID (mm)	Drift API (mm)					

(1) The closed-end displacement does not account for couplings. MPa × 145 = psi daN × 2.25 = lb daN.m × 7.38 = lb.ft mm × 0.0394 = in

GEOMETRICAL CHARACTERISTICS AND MECHANICAL PROPERTIES OF CASING (continued)

Pipe body	1	Nominal size (OD)	1	13.375 in					339.7 mm					13.375 in				339.7 mm							
	2	Nominal weight	2	68.00 lb/ft					99.2 daN/m					72.00 lb/ft				105.1 daN/m							
	3	Wall thickness	3	0.480 in					12.2 mm					0.514 in				13.1 mm							
	4	Inside diameter	4	12.415 in					315.3 mm					12.347 in				313.6 mm							
	5	Steel cross-section	5	19.45 in ²					12 545 mm ²					20.77 in ²				13 398 mm ²							
	6	Capacity	6	6.29 gal/ft					78.10 l/m					6.22 gal/ft				77.25 l/m							
	7	Displacement (1)	7	7.30 gal/ft					90.65 l/m					7.30 gal/ft				90.65 l/m							
	8	Grade	8	K55	L80	N80	C90	T95	P110	Q125	K55	L80	N80	C90	T95	P110	Q125	K55	L80	N80	C90	T95	P110	Q125	
9	Collapse resistance (MPa)	9	13.4	15.6	15.6	16.0	16.1	16.1	16.1	15.4	18.4	18.4	19.2	19.5	19.9	19.9	15.4	18.4	18.4	19.2	19.5	19.9	19.9		
10	Internal yield pressure (MPa)	10	23.8	34.6	34.6	39.0	41.1	47.6	54.1	25.5	37.1	37.1	41.7	44.1	51.0	58.0	25.5	37.1	37.1	41.7	44.1	51.0	58.0		
11	Pipe body yield strength (1000 daN)	11	476	692	692	778	822	951	1081	508	739	739	831	878	1016	1155	508	739	739	831	878	1016	1155		
Tensile strength (10 ³ daN)	12	Buttress Standard	12	578	687	705	749	788	925	1026	618	734	753	800	842	988	1096	618	734	753	800	842	988	1096	
	13	Buttress Special Clearance	13																						
	14	API STC	14	320	424	428	470	496	577	649	345	458	463	508	535	623	701	345	458	463	508	535	623	701	
	15	API LTC	15																						
Connection efficiency	16	Grant Prideco TCII	16																						
	17	Grant Prideco STL	17				59.9							69.0											
	18	HydriL LX	18				72.1							73.6											
	19	HydriL 563	19				92.2							92.7											
	20	HydriL 511	20																						
	21	HydriL 521	21				68.2							70.0											
	22	Vallourec & Mannesmann New VAM	22				127.9							119.8											
	23	Vallourec & Mannesmann VAM ACE	23				126.0							118.0											
	24	Vallourec & Mannesmann VAM PRO	24																						
	25	Vallourec & Mannesmann VAM TOP	25				102.1							102.1											
	26	Vallourec & Mannesmann FJL	26																						
Connection characteristics	27	Buttress Standard	27	Make-up torque (daN.m)					OD (mm)	ID (mm)	Drift API (mm)	Make-up torque (daN.m)					OD (mm)	ID (mm)	Drift API (mm)						
	28	Buttress Special Clearance	28	K55	LN80	C90/95	P110	Q125				K55	LN80	C90/95	P110	Q125									
	29	API STC	29						365.1		311.4														
	30	API LTC	30	973	1298	1510	1758		365.1		311.4		1403	1632	1900	2138		365.1							
	31	Grant Prideco TCII	31		3539	3539	3539	3539	358.8	316.3	311.4		3762	3762	3762	3762		360.3	316.1						
	32	Grant Prideco STL	32	1180	1505	1505	1505	1505	339.7	316.8	311.4	1464	1674	1674	1674	1674		339.7	313.4						
	33	HydriL LX	33	2779	3457	3932	4339	4813	344.5	312.5	311.4	2847	3729	4000	4474	4881		345.5	312.3						
	34	HydriL 563	34	2847	2847	2847	2847	2847	365.1		311.4	3118	3118	3118	3118	3118		365.1							
	35	HydriL 511	35																						
	36	HydriL 521	36	2725	2725	2725	2725	2725	348.2	313.4	311.4	2956	2956	2956	2956	2956		349.7	312.9						
	37	Vallourec & Mannesmann New VAM	37	2156	2156	2156	2156	2156	365.7		311.4	2156	2156	2156	2156	2156		365.7							
	38	Vallourec & Mannesmann VAM ACE	38	2156	2156	2156	2156	2156	365.1		311.4	2156	2156	2156	2156	2156		365.1							
	39	Vallourec & Mannesmann VAM PRO	39																						
	40	Vallourec & Mannesmann VAM TOP	40	2549	3139	3139	3139	3139	360.0		311.4	2942	3139	3139	3139	3139		361.6							
	41	Vallourec & Mannesmann FJL	41																						

(1) The closed-end displacement does not account for couplings. MPa x 145 = psi daN x 2.25 = lb daN.m x 7.38 = lb.ft mm x 0.0394 = in

GEOMETRICAL CHARACTERISTICS AND MECHANICAL PROPERTIES OF CASING (continued)

Pipe body	1	Nominal size (OD)	1	13.375 in					339.7 mm					13.375 in					339.7 mm				
	2	Nominal weight	2	77.00 lb/ft					112.4 daN/m					80.70 lb/ft					117.8 daN/m				
	3	Wall thickness	3	0.550 in					14.0 mm					0.580 in					14.7 mm				
	4	Inside diameter	4	12.275 in					311.8 mm					12.215 in					310.3 mm				
	5	Steel cross-section	5	22.16 in ²					14 297 mm ²					23.31 in ²					15 041 mm ²				
	6	Capacity	6	6.15 gal/ft					76.35 l/m					6.09 gal/ft					75.60 l/m				
	7	Displacement (1)	7	7.30 gal/ft					90.65 l/m					7.30 gal/ft					90.65 l/m				
	8	Grade	8	K55	L80	N80	C90	T95	P110	Q125	K55	L80	N80	C90	T95	P110	Q125						
	9	Collapse resistance (MPa)	9	17.8	21.4	21.4	22.5	23.0	24.1	24.5	20.4	23.8	23.8	25.4	26.0	27.6	28.5						
	10	Internal yield pressure (MPa)	10	27.3	39.7	39.7	44.7	47.1	54.6	62.0	28.8	41.9	41.9	47.1	49.7	57.6	65.4						
	11	Pipe body yield strength (1000 daN)	11	542	789	789	887	936	1084	1232	570	830	830	933	985	1141	1296						
Tensile strength (10 ³ daN)	12	Buttress Standard	12	659	783	804	853	898	1054	1169	694	824	845	898	945	1109	1230						
	13	Buttress Special Clearance	13																				
	14	API STC	14	372	493	499	548	577	672	756	395	523	529	580	612	713	802						
	15	API LTC	15																				
Connection efficiency	16	Grant Prideco TCII	16																				
	17	Grant Prideco STL	17			59.9																	
	18	Hydril LX	18			75.7							75.9										
	19	Hydril 563	19			90.6							91.1										
	20	Hydril 511	20																				
	21	Hydril 521	21				70.3							71.6									
	22	Vallourec & Mannesmann New VAM	22				112.3							106.7									
	23	Vallourec & Mannesmann VAM ACE	23				110.6							105.1									
	24	Vallourec & Mannesmann VAM PRO	24																				
	25	Vallourec & Mannesmann VAM TOP	25				102.1							102.0									
	26	Vallourec & Mannesmann FJL	26																				
Connection characteristics	27	Buttress Standard	27	Make-up torque (daN.m)					OD (mm)	ID (mm)	Drift API (mm)	Make-up torque (daN.m)					OD (mm)	ID (mm)	Drift API (mm)				
	28	Buttress Special Clearance	28																				
	29	API STC	29																				
	30	API LTC	30																				
	31	Grant Prideco TCII	31		4528	4528	4528	4528	361.9	313.2	307.8		4969	4969	4969	4969	363.2	311.9	306.3				
	32	Grant Prideco STL	32	1356	1708	1708	1708	1708	339.7	314.4	307.8												
	33	Hydril LX	33	3118	3864	4339	4745	5220	345.7	309.8	307.8	3322	4271	4813	5355	5898	345.8	308.3	306.3				
	34	Hydril 563	34	4610	4610	4610	4610	4610	365.1	309.9	307.8	4881	4881	4881	4881	4881	365.1	308.4	306.3				
	35	Hydril 511	35																				
	36	Hydril 521	36	3756	3756	3756	3756	3756	347.6	309.9	307.8	4000	4000	4000	4000	4000	348.9	308.4	306.3				
	37	Vallourec & Mannesmann New VAM	37	2156	2156	2156	2156	2156	365.7		307.8	2156	2156	2156	2156	2156	365.7		306.3				
	38	Vallourec & Mannesmann VAM ACE	38	2156	2156	2156	2156	2156	365.1		307.8	2156	2156	2156	2156	2156	365.1		306.3				
	39	Vallourec & Mannesmann VAM PRO	39																				
	40	Vallourec & Mannesmann VAM TOP	40	3139	3139	3139	3139	3139	363.2		307.8	3139	3139	3139	3139	3139	364.5		306.3				
	41	Vallourec & Mannesmann FJL	41																				

(1) The closed-end displacement does not account for couplings. MPa × 145 = psi daN × 2.25 = lb daN.m × 7.38 = lb.ft mm × 0.0394 = in

GEOMETRICAL CHARACTERISTICS AND MECHANICAL PROPERTIES OF CASING (continued)

Pipe body	1	Nominal size (OD)	1	13.625 in					346.1 mm					14.000 in					355.6 mm				
	2	Nominal weight	2	88.20 lb/ft					128.7 daN/m					82.50 lb/ft					120.4 daN/m				
	3	Wall thickness	3	0.625 in					15.9 mm					0.562 in					14.3 mm				
	4	Inside diameter	4	12.375 in					314.3 mm					12.876 in					327.1 mm				
	5	Steel cross-section	5	25.53 in ²					16 468 mm ²					23.73 in ²					15 307 mm ²				
	6	Capacity	6	6.25 gal/ft					77.60 l/m					6.76 gal/ft					84.01 l/m				
	7	Displacement (1)	7	7.57 gal/ft					94.07 l/m					8.00 gal/ft					99.31 l/m				
	8	Grade	8	K55	L80	N80	C90	T95	P110	Q125	K55	L80	N80	C90	T95	P110	Q125						
	9	Collapse resistance (MPa)	9	23.2	27.4	27.4	28.5	29.3	31.5	33.1	16.7	20.3	20.3	21.3	21.7	22.6	22.7						
	10	Internal yield pressure (MPa)	10	30.4	44.3	44.3	49.8	52.6	60.9	69.2	26.6	38.7	38.7	43.6	46.0	53.3	60.5						
	11	Pipe body yield strength (1000 daN)	11	624	908	908	1022	1079	1249	1419	580	844	844	950	1003	1161	1319						
Tensile strength (10 ³ daN)	12	Buttress Standard	12																				
	13	Buttress Special Clearance	13																				
	14	API STC	14																				
	15	API LTC	15																				
Connection efficiency	16	Grant Prideco TCII	16																				
	17	Grant Prideco STL	17																				
	18	Hydril LX	18	70.7																			
	19	Hydril 563	19																				
	20	Hydril 511	20	91.7																			
	21	Hydril 521	21																				
	22	Vallourec & Mannesmann New VAM	22	73.3																			
	23	Vallourec & Mannesmann VAM ACE	23	100.0																			
	24	Vallourec & Mannesmann VAM PRO	24																				
	25	Vallourec & Mannesmann VAM TOP	25																				
	26	Vallourec & Mannesmann FJL	26																				
Connection characteristics	27	Buttress Standard	27	Make-up torque (daN.m)					OD (mm)	ID (mm)	Drift API (mm)	Make-up torque (daN.m)					OD (mm)	ID (mm)	Drift API (mm)				
	28	Buttress Special Clearance	28	K55	LN80	C90/95	P110	Q125				K55	LN80	C90/95	P110	Q125							
	29	API STC	29																				
	30	API LTC	30																				
	31	Grant Prideco TCII	31																				
	32	Grant Prideco STL	32	1844	2346	2346	2346	2346	346.1	312.3	309.6												
	33	Hydril LX	33																				
	34	Hydril 563	34	5017	5017	5017	5017	5017	371.5		309.6												
	35	Hydril 511	35																				
	36	Hydril 521	36	4393	4393	4393	4393	4393	356.6	312.5	309.6												
	37	Vallourec & Mannesmann New VAM	37	2156	2156	2156	2156	2156	365.7		309.6												
	38	Vallourec & Mannesmann VAM ACE	38																				
	39	Vallourec & Mannesmann VAM PRO	39																				
	40	Vallourec & Mannesmann VAM TOP	40																				
	41	Vallourec & Mannesmann FJL	41																				

(1) The closed-end displacement does not account for couplings. MPa × 145 = psi daN × 2.25 = lb daN.m × 7.38 = lb.ft mm × 0.0394 = in

GEOMETRICAL CHARACTERISTICS AND MECHANICAL PROPERTIES OF CASING (continued)

Pipe body	1	Nominal size (OD)	1	14.000 in 355.6 mm					14.000 in 355.6 mm											
	2	Nominal weight	2	94.80 lb/ft 138.4 daN/m					99.00 lb/ft 144.5 daN/m											
	3	Wall thickness	3	0.656 in 16.7 mm					0.688 in 17.5 mm											
	4	Inside diameter	4	12.688 in 322.3 mm					12.624 in 320.6 mm											
	5	Steel cross-section	5	27.50 in ² 17 742 mm ²					28.77 in ² 18 563 mm ²											
	6	Capacity	6	6.57 gal/ft 81.57 l/m					6.50 gal/ft 80.75 l/m											
	7	Displacement (1)	7	8.00 gal/ft 99.31 l/m					8.00 gal/ft 99.31 l/m											
	8	Grade	8	K55	L80	N80	C90	T95	P110	Q125	K55	L80	N80	C90	T95	P110	Q125			
9	Collapse resistance (MPa)	9	24.3	29.1	29.1	30.2	30.7	33.1	34.9	26.9	33.0	33.0	34.6	35.3	36.8	39.0				
10	Internal yield pressure (MPa)	10	31.1	45.2	45.2	50.9	53.7	62.2	70.7	32.6	47.4	47.4	53.4	56.3	65.2	74.1				
11	Pipe body yield strength (1000 daN)	11	673	979	979	1101	1162	1346	1529	704	1024	1024	1152	1216	1408	1600				
Tensile strength (10 ³ daN)	12	Buttress Standard	12																	
	13	Buttress Special Clearance	13																	
	14	API STC	14																	
	15	API LTC	15																	
Connection efficiency	16	Grant Prideco TCII	16																	
	17	Grant Prideco STL	17																	
	18	Hydril LX	18																	
	19	Hydril 563	19																	
	20	Hydril 511	20																	
	21	Hydril 521	21																	
	22	Vallourec & Mannesmann New VAM	22																	
	23	Vallourec & Mannesmann VAM ACE	23																	
	24	Vallourec & Mannesmann VAM PRO	24																	
	25	Vallourec & Mannesmann VAM TOP	25																	
	26	Vallourec & Mannesmann FJL	26																	
Connection characteristics	27	Buttress Standard	27	Make-up torque (daN.m)					OD (mm)	ID (mm)	Drift API (mm)	Make-up torque (daN.m)					OD (mm)	ID (mm)	Drift API (mm)	
	28	Buttress Special Clearance	28	K55	LN80	C90/95	P110	Q125				K55	LN80	C90/95	P110	Q125				
	29	API STC	29																	
	30	API LTC	30																	
	31	Grant Prideco TCII	31																	
	32	Grant Prideco STL	32																	
	33	Hydril LX	33																	
	34	Hydril 563	34																	
	35	Hydril 511	35																	
	36	Hydril 521	36																	
	37	Vallourec & Mannesmann New VAM	37																	
	38	Vallourec & Mannesmann VAM ACE	38																	
	39	Vallourec & Mannesmann VAM PRO	39																	
	40	Vallourec & Mannesmann VAM TOP	40																	
	41	Vallourec & Mannesmann FJL	41																	

(1) The closed-end displacement does not account for couplings. MPa × 145 = psi daN × 2.25 = lb daN.m × 7.38 = lb.ft mm × 0.0394 = in

GEOMETRICAL CHARACTERISTICS AND MECHANICAL PROPERTIES OF CASING (continued)

Pipe body	1	Nominal size (OD)	1	14.000 in 355.6 mm		16.000 in 406.4 mm													
	2	Nominal weight	2	114.00 lb/ft 166.4 daN/m		65.00 lb/ft 94.9 daN/m													
	3	Wall thickness	3	0.800 in 20.3 mm		0.375 in 9.5 mm													
	4	Inside diameter	4	12.400 in 315.0 mm		15.250 in 387.4 mm													
	5	Steel cross-section	5	33.18 in ² 21 403 mm ²		18.41 in ² 11 876 mm ²													
	6	Capacity	6	6.27 gal/ft 77.91 l/m		9.49 gal/ft 117.84 l/m													
	7	Displacement (1)	7	8.00 gal/ft 99.31 l/m		10.44 gal/ft 129.72 l/m													
	8	Grade	8	K55 L80 N80 C90 T95 P110 Q125	K55 L80 N80 C90 T95 P110 Q125														
	9	Collapse resistance (MPa)	9	36.0 46.5 46.5 50.1 51.7 56.1 59.6	4.4 4.4 4.4 4.4 4.4 4.4 4.4														
10	Internal yield pressure (MPa)	10	37.9 55.2 55.2 62.1 65.5 75.8 86.2	15.6 22.6 22.6 25.5 26.9 31.1 35.3															
11	Pipe body yield strength (1000 daN)	11	812 1181 1181 1328 1402 1623 1845	450 655 655 737 778 901 1024															
Tensile strength (10 ³ daN)	12	Buttress Standard	12			509	632	645	694	731	855	954							
	13	Buttress Special Clearance	13																
	14	API STC	14			278	371	375	412	435	506	570							
	15	API LTC	15																
Connection efficiency	16	Grant Prideco TCII	16																
	17	Grant Prideco STL	17																
	18	Hydril LX	18																
	19	Hydril 563	19	93.5															
	20	Hydril 511	20																
	21	Hydril 521	21																
	22	Vallourec & Mannesmann New VAM	22																
	23	Vallourec & Mannesmann VAM ACE	23																
	24	Vallourec & Mannesmann VAM PRO	24																
	25	Vallourec & Mannesmann VAM TOP	25																
	26	Vallourec & Mannesmann FJL	26																
Connection characteristics	27	Buttress Standard	27	Make-up torque (daN.m)					Make-up torque (daN.m)					OD (mm)	ID (mm)	Drift API (mm)			
	28	Buttress Special Clearance	28	K55	LN80	C90/95	P110	Q125	OD (mm)	ID (mm)	Drift API (mm)	K55	LN80	C90/95	P110	Q125	OD (mm)	ID (mm)	Drift API (mm)
	29	API STC	29														431.8		382.6
	30	API LTC	30																
	31	Grant Prideco TCII	31																
	32	Grant Prideco STL	32																
	33	Hydril LX	33																
	34	Hydril 563	34	7593	7593	7593	7593	7593	381.0			310.2							
	35	Hydril 511	35																
	36	Hydril 521	36																
	37	Vallourec & Mannesmann New VAM	37																
	38	Vallourec & Mannesmann VAM ACE	38																
	39	Vallourec & Mannesmann VAM PRO	39																
	40	Vallourec & Mannesmann VAM TOP	40																
	41	Vallourec & Mannesmann FJL	41																

(1) The closed-end displacement does not account for couplings. MPa × 145 = psi daN × 2.25 = lb daN.m × 7.38 = lb.ft mm × 0.0394 = in

GEOMETRICAL CHARACTERISTICS AND MECHANICAL PROPERTIES OF CASING (continued)

Pipe body	1	Nominal size (OD)	1	16.000 in 406.4 mm					16.000 in 406.4 mm										
	2	Nominal weight	2	75.00 lb/ft 109.5 daN/m					84.00 lb/ft 122.6 daN/m										
	3	Wall thickness	3	0.438 in 11.1 mm					0.495 in 12.6 mm										
	4	Inside diameter	4	15.124 in 384.1 mm					15.010 in 381.3 mm										
	5	Steel cross-section	5	21.41 in ² 13 815 mm ²					24.11 in ² 15 556 mm ²										
	6	Capacity	6	9.33 gal/ft 115.90 l/m					9.19 gal/ft 114.16 l/m										
	7	Displacement (1)	7	10.44 gal/ft 129.72 l/m					10.44 gal/ft 129.72 l/m										
	8	Grade	8	K55	L80	N80	C90	T95	P110	Q125	K55	L80	N80	C90	T95	P110	Q125		
	9	Collapse resistance (MPa)	9	7.0	7.0	7.0	7.0	7.0	7.0	7.0	9.7	10.2	10.2	10.2	10.2	10.2	10.2		
	10	Internal yield pressure (MPa)	10	18.2	26.4	26.4	29.7	31.4	36.3	41.3	20.5	29.9	29.9	33.6	35.5	41.1	46.7		
	11	Pipe body yield strength (1000 daN)	11	524	762	762	857	905	1048	1191	590	858	858	965	1019	1180	1341		
Tensile strength (10 ³ daN)	12	Buttress Standard	12	592	735	750	807	850	995	1110	667	828	844	909	958	1120	1250		
	13	Buttress Special Clearance	13																
	14	API STC	14	334	446	451	496	523	609	685	385	514	519	571	602	701	789		
	15	API LTC	15																
Connection efficiency	16	Grant Prideco TCII	16																
	17	Grant Prideco STL	17																
	18	Hydriil LX	18																
	19	Hydriil 563	19	91.6					92.5										
	20	Hydriil 511	20																
	21	Hydriil 521	21	65.6					69.0										
	22	Vallourec & Mannesmann New VAM	22																
	23	Vallourec & Mannesmann VAM ACE	23																
	24	Vallourec & Mannesmann VAM PRO	24																
	25	Vallourec & Mannesmann VAM TOP	25																
	26	Vallourec & Mannesmann FJL	26																
Connection characteristics	27	Buttress Standard	27	Make-up torque (daN.m)					OD (mm)	ID (mm)	Drift API (mm)	Make-up torque (daN.m)					OD (mm)	ID (mm)	Drift API (mm)
	28	Buttress Special Clearance	28																
	29	API STC	29	1020					431.8		379.4	1173					431.8		376.5
	30	API LTC	30						431.8		379.4						431.8		376.5
	31	Grant Prideco TCII	31						431.8	382.2	379.4	3525	3525	3525	3525	3525	431.8		376.5
	32	Grant Prideco STL	32						431.8	382.2	379.4	3525	3525	3525	3525	3525	431.8		376.5
	33	Hydriil LX	33						431.8	382.2	379.4	3525	3525	3525	3525	3525	431.8		376.5
	34	Hydriil 563	34	3254	3254	3254	3254	3254	431.8	382.2	379.4	3525	3525	3525	3525	3525	431.8		376.5
	35	Hydriil 511	35						431.8	382.2	379.4	3525	3525	3525	3525	3525	431.8		376.5
	36	Hydriil 521	36	2725	2725	2725	2725	2725	410.3	382.2	379.4	3159	3159	3159	3159	3159	412.9	379.3	376.5
	37	Vallourec & Mannesmann New VAM	37																
	38	Vallourec & Mannesmann VAM ACE	38																
	39	Vallourec & Mannesmann VAM PRO	39																
	40	Vallourec & Mannesmann VAM TOP	40																
	41	Vallourec & Mannesmann FJL	41																

(1) The closed-end displacement does not account for couplings. MPa × 145 = psi daN × 2.25 = lb daN.m × 7.38 = lb.ft mm × 0.0394 = in

GEOMETRICAL CHARACTERISTICS AND MECHANICAL PROPERTIES OF CASING (continued)

Pipe body	1	Nominal size (OD)	1	16.000 in					406.4 mm					16.000 in					406.4 mm					
	2	Nominal weight	2	94.50 lb/ft					137.9 daN/m					109.00 lb/ft					159.1 daN/m					
	3	Wall thickness	3	0.562 in					14.3 mm					0.656 in					16.7 mm					
	4	Inside diameter	4	14.876 in					377.9 mm					14.688 in					373.1 mm					
	5	Steel cross-section	5	27.26 in ²					17 585 mm ²					31.62 in ²					20 401 mm ²					
	6	Capacity	6	9.03 gal/ft					112.13 l/m					8.80 gal/ft					109.32 l/m					
	7	Displacement (1)	7	10.44 gal/ft					129.72 l/m					10.44 gal/ft					129.72 l/m					
	8	Grade	8	K55	L80	N80	C90	T95	P110	Q125	K55	L80	N80	C90	T95	P110	Q125	K55	L80	N80	C90	T95	P110	Q125
	9	Collapse resistance (MPa)	9	12.9	14.8	14.8	15.0	15.1	15.1	15.1	17.7	21.2	21.2	22.4	22.9	23.9	24.3	17.7	21.2	21.2	22.4	22.9	23.9	24.3
	10	Internal yield pressure (MPa)	10	23.3	33.9	33.9	38.1	40.3	46.6	53.0	27.2	39.6	39.6	44.5	47.0	54.4	61.8	27.2	39.6	39.6	44.5	47.0	54.4	61.8
	11	Pipe body yield strength (1000 daN)	11	667	970	970	1091	1152	1334	1516	774	1125	1125	1266	1336	1547	1758	774	1125	1125	1266	1336	1547	1758
Tensile strength (10 ³ daN)	12	Buttress Standard	12	754	936	955	1027	1083	1266	1413	874	1086	1107	1192	1256	1469	1639	874	1086	1107	1192	1256	1469	1639
	13	Buttress Special Clearance	13																					
	14	API STC	14	444	593	599	658	694	808	910	526	702	709	780	822	957	1077	526	702	709	780	822	957	1077
	15	API LTC	15																					
Connection efficiency	16	Grant Prideco TCII	16																					
	17	Grant Prideco STL	17																					
	18	HydriL LX	18																					
	19	HydriL 563	19																					
	20	HydriL 511	20																					
	21	HydriL 521	21																					
	22	Vallourec & Mannesmann New VAM	22																					
	23	Vallourec & Mannesmann VAM ACE	23																					
	24	Vallourec & Mannesmann VAM PRO	24																					
	25	Vallourec & Mannesmann VAM TOP	25																					
	26	Vallourec & Mannesmann FJL	26																					
Connection characteristics	27	Buttress Standard	27	Make-up torque (daN.m)					OD (mm)	ID (mm)	Drift API (mm)	Make-up torque (daN.m)					OD (mm)	ID (mm)	Drift API (mm)					
	28	Buttress Special Clearance	28	K55	LN80	C90/95	P110	Q125	431.8		373.1	K55	LN80	C90/95	P110	Q125	431.8		368.3					
	29	API STC	29																					
	30	API LTC	30																					
	31	Grant Prideco TCII	31																					
	32	Grant Prideco STL	32																					
	33	HydriL LX	33																					
	34	HydriL 563	34									6644	6644	6644	6644	6644	431.8		368.3					
	35	HydriL 511	35																					
	36	HydriL 521	36									5355	5355	5355	5355	5355	418.2	371.2	368.3					
	37	Vallourec & Mannesmann New VAM	37																					
	38	Vallourec & Mannesmann VAM ACE	38																					
	39	Vallourec & Mannesmann VAM PRO	39																					
	40	Vallourec & Mannesmann VAM TOP	40																					
	41	Vallourec & Mannesmann FJL	41																					

(1) The closed-end displacement does not account for couplings. MPa × 145 = psi daN × 2.25 = lb daN.m × 7.38 = lb.ft mm × 0.0394 = in

GEOMETRICAL CHARACTERISTICS AND MECHANICAL PROPERTIES OF CASING (continued)

Pipe body	1	Nominal size (OD)	1	16.000 in					406.4 mm					18.625 in					473.1 mm								
	2	Nominal weight	2	128.00 lb/ft					186.8 daN/m					87.50 lb/ft					127.7 daN/m								
	3	Wall thickness	3	0.781 in					19.8 mm					0.435 in					11.0 mm								
	4	Inside diameter	4	14.438 in					366.7 mm					17.755 in					451.0 mm								
	5	Steel cross-section	5	37.34 in ²					24 091 mm ²					24.86 in ²					16 038 mm ²								
	6	Capacity	6	8.51 gal/ft					105.63 l/m					12.86 gal/ft					159.73 l/m								
	7	Displacement (l)	7	10.44 gal/ft					129.72 l/m					14.15 gal/ft					175.77 l/m								
	8	Grade	8	K55	L80	N80	C90	T95	P110	Q125	K55	L80	N80	C90	T95	P110	Q125										
	9	Collapse resistance (MPa)	9	26.5	32.4	32.4	34.0	34.6	36.1	38.4	4.3	4.3	4.3	4.3	4.3	4.3	4.3										
	10	Internal yield pressure (MPa)	10	32.4	47.1	47.1	53.0	56.0	64.8	73.6	15.5	22.5	22.5	25.4	26.8	31.0	35.2										
	11	Pipe body yield strength (1000 daN)	11	914	1329	1329	1495	1578	1827	2076	608	885	885	995	1050	1216	1382										
Tensile strength (10 ³ daN)	12	Buttress Standard	12	1032	1282	1308	1402	1472	1735	1893	635	829	840	917	967	1127	1265										
	13	Buttress Special Clearance	13																								
	14	API STC	14	633	845	854	939	990	1152	1297	353	475	480	529	557	649	731										
	15	API LTC	15																								
Connection efficiency	16	Grant Prideco TCII	16																								
	17	Grant Prideco STL	17																								
	18	Hydril LX	18																								
	19	Hydril 563	19																								
	20	Hydril 511	20																								
	21	Hydril 521	21																								
	22	Vallourec & Mannesmann New VAM	22																								
	23	Vallourec & Mannesmann VAM ACE	23																								
	24	Vallourec & Mannesmann VAM PRO	24																								
	25	Vallourec & Mannesmann VAM TOP	25																								
	26	Vallourec & Mannesmann FJL	26																								
Connection characteristics	27	Buttress Standard	27	Make-up torque (daN.m)					OD (mm)	ID (mm)	Drift API (mm)	Make-up torque (daN.m)					OD (mm)	ID (mm)	Drift API (mm)								
	28	Buttress Special Clearance	28	K55	LN80	C90/95	P110	Q125	431.8		362.0	K55	LN80	C90/95	P110	Q125	508.0		446.2								
	29	API STC	29								1077					508.0		446.2									
	30	API LTC	30																								
	31	Grant Prideco TCII	31																								
	32	Grant Prideco STL	32																								
	33	Hydril LX	33																								
	34	Hydril 563	34													508.0	449.1	446.2									
	35	Hydril 511	35																								
	36	Hydril 521	36									3539	3539	3539	3539	3539	478.9	448.0	446.2								
	37	Vallourec & Mannesmann New VAM	37																								
	38	Vallourec & Mannesmann VAM ACE	38																								
	39	Vallourec & Mannesmann VAM PRO	39																								
	40	Vallourec & Mannesmann VAM TOP	40																								
	41	Vallourec & Mannesmann FJL	41																								

(1) The closed-end displacement does not account for couplings. MPa × 145 = psi daN × 2.25 = lb daN.m × 7.38 = lb.ft mm × 0.0394 = in

GEOMETRICAL CHARACTERISTICS AND MECHANICAL PROPERTIES OF CASING (continued)

Pipe body	1	Nominal size (OD)	1	20.000 in					508.0 mm					20.000 in					508.0 mm				
	2	Nominal weight	2	94.00 lb/ft					137.2 daN/m					106.50 lb/ft					155.4 daN/m				
	3	Wall thickness	3	0.438 in					11.1 mm					0.500 in					12.7 mm				
	4	Inside diameter	4	19.124 in					485.7 mm					19.000 in					482.6 mm				
	5	Steel cross-section	5	26.92 in ²					17 366 mm ²					30.63 in ²					19 762 mm ²				
	6	Capacity	6	14.92 gal/ft					185.32 l/m					14.73 gal/ft					182.92 l/m				
	7	Displacement (1)	7	16.32 gal/ft					202.68 l/m					16.32 gal/ft					202.68 l/m				
	8	Grade	8	K55	L80	N80	C90	T95	P110	Q125	K55	L80	N80	C90	T95	P110	Q125						
	9	Collapse resistance (MPa)	9	3.6	3.6	3.6	3.6	3.6	3.6	3.6	5.3	5.3	5.3	5.3	5.3	5.3	5.3						
	10	Internal yield pressure (MPa)	10	14.5	21.1	21.1	23.8	25.1	29.1	33.0	16.6	24.1	24.1	27.1	28.7	33.2	37.7						
	11	Pipe body yield strength (1000 daN)	11	659	958	958	1078	1137	1317	1497	749	1090	1090	1226	1294	1499	1703						
Tensile strength (10 ³ daN)	12	Buttress Standard	12	658	883	892	982	1035	1205	1357	749	1005	1015	1117	1178	1371	1544						
	13	Buttress Special Clearance	13																				
	14	API STC	14	366	495	499	550	580	675	761	427	576	581	641	676	787	887						
	15	API LTC	15	425	572	577	636	670	780	879	495	666	672	741	781	909	1024						
Connection efficiency	16	Grant Prideco TCII	16																				
	17	Grant Prideco STL	17																				
	18	Hydril LX	18																				
	19	Hydril 563	19																				
	20	Hydril 511	20																				
	21	Hydril 521	21																				
	22	Vallourec & Mannesmann New VAM	22																				
	23	Vallourec & Mannesmann VAM ACE	23																				
	24	Vallourec & Mannesmann VAM PRO	24																				
	25	Vallourec & Mannesmann VAM TOP	25																				
	26	Vallourec & Mannesmann FJL	26																				
Connection characteristics	27	Buttress Standard	27	Make-up torque (daN.m)					OD (mm)	ID (mm)	Drift API (mm)	Make-up torque (daN.m)					OD (mm)	ID (mm)	Drift API (mm)				
	28	Buttress Special Clearance	28																				
	29	API STC	29																				
	30	API LTC	30	1116																			
	31	Grant Prideco TCII	31	1295																			
	32	Grant Prideco STL	32																				
	33	Hydril LX	33																				
	34	Hydril 563	34																				
	35	Hydril 511	35																				
	36	Hydril 521	36																				
	37	Vallourec & Mannesmann New VAM	37																				
	38	Vallourec & Mannesmann VAM ACE	38																				
	39	Vallourec & Mannesmann VAM PRO	39																				
40	Vallourec & Mannesmann VAM TOP	40																					
41	Vallourec & Mannesmann FJL	41																					

(1) The closed-end displacement does not account for couplings. MPa × 145 = psi daN × 2.25 = lb daN.m × 7.38 = lb.ft mm × 0.0394 = in

GEOMETRICAL CHARACTERISTICS AND MECHANICAL PROPERTIES OF CASING (continued)

			Make-up torque (daN.m)								OD (mm)	ID (mm)	Drift API (mm)				
			K55	LN80	C90/95	P110	Q125										
Pipe body	1	Nominal size (OD)	1	20.000 in					508.0 mm								
	2	Nominal weight	2	133.00 lb/ft					194.1 daN/m								
	3	Wall thickness	3	0.635 in					16.1 mm								
	4	Inside diameter	4	18.730 in					475.7 mm								
	5	Steel cross-section	5	38.63 in ²					24 923 mm ²								
	6	Capacity	6	14.31 gal/ft					177.76 l/m								
	7	Displacement (1)	7	16.32 gal/ft					202.68 l/m								
	8	Grade	8	K55	L80	N80	C90	T95	P110	Q125							
	9	Collapse resistance (MPa)	9	10.3	11.1	11.1	11.1	11.1	11.1	11.1							
	10	Internal yield pressure (MPa)	10	21.1	30.6	30.6	34.5	36.4	42.1	47.9							
	11	Pipe body yield strength (1000 daN)	11	945	1375	1375	1547	1632	1890	2148							
Tensile strength (10 ³ daN)	12	Buttress Standard	12	944	1267	1280	1409	1486	1729	1947							
	13	Buttress Special Clearance	13														
	14	API STC	14	557	752	759	837	883	1027	1158							
	15	API LTC	15	647	870	878	967	1020	1187	1337							
Connection efficiency	16	Grant Prideco TCII	16														
	17	Grant Prideco STL	17														
	18	Hydril LX	18														
	19	Hydril 563	19														
	20	Hydril 511	20														
	21	Hydril 521	21														
	22	Vallourec & Mannesmann New VAM	22														
	23	Vallourec & Mannesmann VAM ACE	23														
	24	Vallourec & Mannesmann VAM PRO	24														
	25	Vallourec & Mannesmann VAM TOP	25														
	26	Vallourec & Mannesmann FJL	26														
Connection characteristics	27	Buttress Standard	27						533.4		471.0						
	28	Buttress Special Clearance	28														
	29	API STC	29	1697					533.4		471.0						
	30	API LTC	30	1970					533.4		471.0						
	31	Grant Prideco TCII	31														
	32	Grant Prideco STL	32														
	33	Hydril LX	33														
	34	Hydril 563	34														
	35	Hydril 511	35														
	36	Hydril 521	36														
	37	Vallourec & Mannesmann New VAM	37														
	38	Vallourec & Mannesmann VAM ACE	38														
	39	Vallourec & Mannesmann VAM PRO	39														
	40	Vallourec & Mannesmann VAM TOP	40														
	41	Vallourec & Mannesmann FJL	41														

(1) The closed-end displacement does not account for couplings. MPa × 145 = psi daN × 2.25 = lb daN.m × 7.38 = lb.ft mm × 0.0394 = in

GEOMETRICAL CHARACTERISTICS AND MECHANICAL PROPERTIES OF COILED TUBING

Coiled tubing dimensions and specifications					Calculated coiled tubing performance properties								
Outside diameter (in)	Body weight (lb/ft)	Yield strength (psi)	Wall thickness (in)		Inside diameter (in)	Tube area (in ²)		Tension yield (kN)	Internal yield (MPa)	Torsional yield (N.m)	Capacity (l/m)	Wall displacement (l/m)	External displacement (l/m)
			Nominal (in)	Minimum (in)		Nominal (in ²)	Minimum (in ²)						
0.750	0.59	55 000	0.083	0.078	0.584	0.174	0.165	40	79	188	0.173	0.112	0.285
0.750	0.59	75 000	0.083	0.078	0.584	0.174	0.165	55	108	256	0.173	0.112	0.285
0.750	0.62	80 000	0.087	0.082	0.576	0.181	0.172	61	121	282	0.168	0.117	0.285
1.000	0.81	55 000	0.083	0.078	0.834	0.239	0.226	55	59	364	0.352	0.154	0.507
1.000	0.79	70 000	0.080	0.075	0.840	0.231	0.218	68	72	450	0.358	0.149	0.507
1.000	0.81	70 000	0.083	0.078	0.834	0.239	0.226	70	75	463	0.352	0.154	0.507
1.000	0.85	70 000	0.087	0.082	0.826	0.250	0.236	74	79	479	0.346	0.161	0.507
1.000	0.92	70 000	0.095	0.090	0.810	0.270	0.257	80	87	511	0.332	0.174	0.507
1.000	0.98	70 000	0.102	0.097	0.796	0.288	0.275	86	94	537	0.321	0.186	0.507
1.000	1.04	70 000	0.109	0.104	0.782	0.305	0.293	91	100	561	0.310	0.197	0.507
1.000	1.17	70 000	0.125	0.117	0.750	0.344	0.325	101	113	613	0.285	0.222	0.507
1.000	0.81	75 000	0.083	0.078	0.834	0.239	0.226	75	81	496	0.352	0.154	0.507
1.000	0.85	75 000	0.087	0.082	0.826	0.250	0.236	79	85	513	0.346	0.161	0.507
1.000	0.79	80 000	0.080	0.075	0.840	0.231	0.218	78	83	515	0.358	0.149	0.507
1.000	0.85	80 000	0.087	0.082	0.826	0.250	0.236	84	90	548	0.346	0.161	0.507
1.000	0.92	80 000	0.095	0.090	0.810	0.270	0.257	92	99	584	0.332	0.174	0.507
1.000	0.98	80 000	0.102	0.097	0.796	0.288	0.275	98	107	613	0.321	0.186	0.507
1.000	1.04	80 000	0.109	0.104	0.782	0.305	0.293	104	115	641	0.310	0.197	0.507
1.000	1.17	80 000	0.125	0.117	0.750	0.344	0.325	115	129	700	0.285	0.222	0.507
1.000	0.79	90 000	0.080	0.075	0.840	0.231	0.218	87	93	579	0.358	0.149	0.507
1.000	0.85	90 000	0.087	0.082	0.826	0.250	0.236	95	102	616	0.346	0.161	0.507
1.000	0.92	90 000	0.095	0.090	0.810	0.270	0.257	103	112	657	0.332	0.174	0.507
1.000	0.98	90 000	0.102	0.097	0.796	0.288	0.275	110	120	690	0.321	0.186	0.507
1.000	1.04	90 000	0.109	0.104	0.782	0.305	0.293	117	129	722	0.310	0.197	0.507
1.000	1.17	90 000	0.125	0.117	0.750	0.344	0.325	130	145	788	0.285	0.222	0.507
1.000	0.79	100 000	0.080	0.075	0.840	0.231	0.218	97	103	643	0.358	0.149	0.507
1.000	0.85	100 000	0.087	0.082	0.826	0.250	0.236	105	113	685	0.346	0.161	0.507
1.000	0.92	100 000	0.095	0.090	0.810	0.270	0.257	114	124	729	0.332	0.174	0.507
1.000	0.98	100 000	0.102	0.097	0.796	0.288	0.275	122	134	767	0.321	0.186	0.507
1.000	1.17	100 000	0.125	0.117	0.750	0.344	0.325	144	161	876	0.285	0.222	0.507
1.250	1.03	55 000	0.083	0.078	1.084	0.304	0.287	70	47	598	0.595	0.196	0.792
1.250	1.17	55 000	0.095	0.090	1.060	0.345	0.328	80	55	664	0.569	0.222	0.792

kN x 0.225 = kip MPa x 145 = psi N.m x 0.738 = lb.ft l/m x 0.0805 = gal/ft l/m x 0.00192 = bbl/ft

GEOMETRICAL CHARACTERISTICS AND MECHANICAL PROPERTIES OF COILED TUBING (continued)

Coiled tubing dimensions and specifications					Calculated coiled tubing performance properties								
Outside diameter (in)	Body weight (lb/ft)	Yield strength (psi)	Wall thickness		Inside diameter (in)	Tube area		Tension yield (kN)	Internal yield (MPa)	Torsional yield (N.m)	Capacity (l/m)	Wall displacement (l/m)	External displacement (l/m)
			Nominal (in)	Minimum (in)		Nominal (in ²)	Minimum (in ²)						
1.250	1.00	70 000	0.080	0.075	1.090	0.294	0.277	86	58	739	0.602	0.190	0.792
1.250	1.03	70 000	0.083	0.078	1.084	0.304	0.287	89	60	761	0.595	0.196	0.792
1.250	1.08	70 000	0.087	0.082	1.076	0.318	0.301	94	63	790	0.587	0.205	0.792
1.250	1.17	70 000	0.095	0.090	1.060	0.345	0.328	102	69	846	0.569	0.222	0.792
1.250	1.25	70 000	0.102	0.097	1.046	0.368	0.351	109	75	893	0.554	0.237	0.792
1.250	1.33	70 000	0.109	0.104	1.032	0.391	0.374	117	80	938	0.540	0.252	0.792
1.250	1.50	70 000	0.125	0.117	1.000	0.442	0.416	130	90	1 034	0.507	0.285	0.792
1.250	1.60	70 000	0.134	0.126	0.982	0.470	0.445	139	97	1 084	0.489	0.303	0.792
1.250	1.82	70 000	0.156	0.148	0.938	0.536	0.512	160	114	1 196	0.446	0.346	0.792
1.250	2.01	70 000	0.175	0.167	0.900	0.591	0.568	177	129	1 281	0.410	0.381	0.792
1.250	1.03	75 000	0.083	0.078	1.084	0.304	0.287	96	65	815	0.595	0.196	0.792
1.250	1.08	75 000	0.087	0.082	1.076	0.318	0.301	100	68	846	0.587	0.205	0.792
1.250	1.17	75 000	0.095	0.090	1.060	0.345	0.328	109	74	906	0.569	0.222	0.792
1.250	1.33	75 000	0.109	0.104	1.032	0.391	0.374	125	86	1 005	0.540	0.252	0.792
1.250	1.00	80 000	0.080	0.075	1.090	0.294	0.277	99	66	844	0.602	0.190	0.792
1.250	1.08	80 000	0.087	0.082	1.076	0.318	0.301	107	72	902	0.587	0.205	0.792
1.250	1.17	80 000	0.095	0.090	1.060	0.345	0.328	117	79	966	0.569	0.222	0.792
1.250	1.25	80 000	0.102	0.097	1.046	0.368	0.351	125	86	1 020	0.554	0.237	0.792
1.250	1.33	80 000	0.109	0.104	1.032	0.391	0.374	133	92	1 071	0.540	0.252	0.792
1.250	1.50	80 000	0.125	0.117	1.000	0.442	0.416	148	103	1 182	0.507	0.285	0.792
1.250	1.60	80 000	0.134	0.126	0.982	0.470	0.445	158	111	1 239	0.489	0.303	0.792
1.250	1.82	80 000	0.156	0.148	0.938	0.536	0.512	182	131	1 367	0.446	0.346	0.792
1.250	2.01	80 000	0.175	0.167	0.900	0.591	0.568	202	147	1 463	0.410	0.381	0.792
1.250	1.00	90 000	0.080	0.075	1.090	0.294	0.277	111	74	950	0.602	0.190	0.792
1.250	1.08	90 000	0.087	0.082	1.076	0.318	0.301	120	81	1 015	0.587	0.205	0.792
1.250	1.17	90 000	0.095	0.090	1.060	0.345	0.328	131	89	1 087	0.569	0.222	0.792
1.250	1.25	90 000	0.102	0.097	1.046	0.368	0.351	141	96	1 148	0.554	0.237	0.792
1.250	1.33	90 000	0.109	0.104	1.032	0.391	0.374	150	103	1 205	0.540	0.252	0.792
1.250	1.50	90 000	0.125	0.117	1.000	0.442	0.416	167	116	1 329	0.507	0.285	0.792
1.250	1.60	90 000	0.134	0.126	0.982	0.470	0.445	178	125	1 394	0.489	0.303	0.792
1.250	1.82	90 000	0.156	0.148	0.938	0.536	0.512	205	147	1 538	0.446	0.346	0.792
1.250	2.01	90 000	0.175	0.167	0.900	0.591	0.568	227	166	1 646	0.410	0.381	0.792
1.250	1.00	100 000	0.080	0.075	1.090	0.294	0.277	123	83	1 055	0.602	0.190	0.792
1.250	1.08	100 000	0.087	0.082	1.076	0.318	0.301	134	90	1 128	0.587	0.205	0.792
1.250	1.17	100 000	0.095	0.090	1.060	0.345	0.328	146	99	1 208	0.569	0.222	0.792
1.250	1.25	100 000	0.102	0.097	1.046	0.368	0.351	156	107	1 275	0.554	0.237	0.792

kN x 0.225 = kip MPa x 145 = psi N.m x 0.738 = lb.ft l/m x 0.0805 = gal/ft l/m x 0.00192 = bb/ft

GEOMETRICAL CHARACTERISTICS AND MECHANICAL PROPERTIES OF COILED TUBING (continued)

Coiled tubing dimensions and specifications					Calculated coiled tubing performance properties								
Outside diameter (in)	Body weight (lb/ft)	Yield strength (psi)	Wall thickness		Inside diameter (in)	Tube area		Tension yield (kN)	Internal yield (MPa)	Torsional yield (N.m)	Capacity (l/m)	Wall displacement (l/m)	External displacement (l/m)
			Nominal (in)	Minimum (in)		Nominal (in ²)	Minimum (in ²)						
1.250	1.33	100 000	0.109	0.104	1.032	0.391	0.374	167	115	1 339	0.540	0.252	0.792
1.250	1.50	100 000	0.125	0.117	1.000	0.442	0.416	185	129	1 477	0.507	0.285	0.792
1.250	1.60	100 000	0.134	0.126	0.982	0.470	0.445	198	139	1 549	0.489	0.303	0.792
1.250	1.82	100 000	0.156	0.148	0.938	0.536	0.512	228	163	1 708	0.446	0.346	0.792
1.250	2.01	100 000	0.175	0.167	0.900	0.591	0.568	253	184	1 829	0.410	0.381	0.792
1.500	1.43	75 000	0.095	0.090	1.310	0.419	0.399	133	62	1 356	0.870	0.271	1.140
1.500	1.62	75 000	0.109	0.104	1.282	0.476	0.456	152	72	1 512	0.833	0.307	1.140
1.500	1.43	80 000	0.095	0.090	1.310	0.419	0.399	142	66	1 446	0.870	0.271	1.140
1.500	1.52	80 000	0.102	0.097	1.296	0.448	0.428	152	71	1 531	0.851	0.289	1.140
1.500	1.62	80 000	0.109	0.104	1.282	0.476	0.456	162	76	1 613	0.833	0.307	1.140
1.500	1.84	80 000	0.125	0.117	1.250	0.540	0.508	181	86	1 790	0.792	0.348	1.140
1.500	1.95	80 000	0.134	0.126	1.232	0.575	0.544	194	93	1 884	0.769	0.371	1.140
1.500	2.24	80 000	0.156	0.148	1.188	0.659	0.629	224	109	2 098	0.715	0.425	1.140
1.500	2.48	80 000	0.175	0.167	1.150	0.728	0.699	249	123	2 263	0.670	0.470	1.140
1.500	1.43	90 000	0.095	0.090	1.310	0.419	0.399	160	74	1 627	0.870	0.271	1.140
1.500	1.52	90 000	0.102	0.097	1.296	0.448	0.428	171	80	1 722	0.851	0.289	1.140
1.500	1.62	90 000	0.109	0.104	1.282	0.476	0.456	183	86	1 815	0.833	0.307	1.140
1.500	1.84	90 000	0.125	0.117	1.250	0.540	0.508	204	97	2 014	0.792	0.348	1.140
1.500	1.95	90 000	0.134	0.126	1.232	0.575	0.544	218	104	2 120	0.769	0.371	1.140
1.500	2.24	90 000	0.156	0.148	1.188	0.659	0.629	252	122	2 360	0.715	0.425	1.140
1.500	2.48	90 000	0.175	0.167	1.150	0.728	0.699	280	138	2 546	0.670	0.470	1.140
1.500	1.43	100 000	0.095	0.090	1.310	0.419	0.399	177	83	1 808	0.870	0.271	1.140
1.500	1.52	100 000	0.102	0.097	1.296	0.448	0.428	190	89	1 914	0.851	0.289	1.140
1.500	1.62	100 000	0.109	0.104	1.282	0.476	0.456	203	96	2 016	0.833	0.307	1.140
1.500	1.84	100 000	0.125	0.117	1.250	0.540	0.508	226	108	2 238	0.792	0.348	1.140
1.500	1.95	100 000	0.134	0.126	1.232	0.575	0.544	242	116	2 356	0.769	0.371	1.140
1.500	2.24	100 000	0.156	0.148	1.188	0.659	0.629	280	136	2 622	0.715	0.425	1.140
1.500	2.48	100 000	0.175	0.167	1.150	0.728	0.699	311	154	2 829	0.670	0.470	1.140
1.750	1.48	55 000	0.083	0.078	1.584	0.435	0.410	100	34	1 241	1.271	0.280	1.552
1.750	1.55	55 000	0.087	0.082	1.576	0.455	0.430	105	36	1 292	1.259	0.293	1.552
1.750	1.68	55 000	0.095	0.090	1.560	0.494	0.469	115	39	1 391	1.233	0.319	1.552
1.750	1.91	70 000	0.109	0.104	1.532	0.562	0.538	167	57	1 983	1.189	0.363	1.552
1.750	2.17	70 000	0.125	0.117	1.500	0.638	0.600	187	65	2 211	1.140	0.412	1.552
1.750	2.31	70 000	0.134	0.126	1.482	0.680	0.643	200	69	2 334	1.113	0.439	1.552
1.750	2.66	70 000	0.156	0.148	1.438	0.781	0.745	232	82	2 614	1.048	0.504	1.552

kN x 0.225 = kip MPa x 145 = psi N.m x 0.738 = lb.ft l/m x 0.0805 = gal/ft l/m x 0.00192 = bb/ft

GEOMETRICAL CHARACTERISTICS AND MECHANICAL PROPERTIES OF COILED TUBING (continued)

Coiled tubing dimensions and specifications				Calculated coiled tubing performance properties									
Outside diameter (in)	Body weight (lb/ft)	Yield strength (psi)	Wall thickness (in)		Inside diameter (in)	Tube area (in ²)		Tension yield (kN)	Internal yield (MPa)	Torsional yield (N.m)	Capacity (l/m)	Wall displacement (l/m)	External displacement (l/m)
			Nominal	Minimum		Nominal	Minimum						
1.750	2.94	70 000	0.175	0.167	1.400	0.866	0.831	259	92	2 837	0.993	0.559	1.552
1.750	3.14	70 000	0.188	0.180	1.374	0.923	0.888	276	99	2 979	0.957	0.595	1.552
1.750	1.68	75 000	0.095	0.090	1.560	0.494	0.469	157	53	1 897	1.233	0.319	1.552
1.750	1.68	80 000	0.095	0.090	1.560	0.494	0.469	167	57	2 024	1.233	0.319	1.552
1.750	1.91	80 000	0.109	0.104	1.532	0.562	0.538	191	66	2 266	1.189	0.363	1.552
1.750	2.17	80 000	0.125	0.117	1.500	0.638	0.600	214	74	2 527	1.140	0.412	1.552
1.750	2.31	80 000	0.134	0.126	1.482	0.680	0.643	229	79	2 667	1.113	0.439	1.552
1.750	2.66	80 000	0.156	0.148	1.438	0.781	0.745	265	93	2 988	1.048	0.504	1.552
1.750	2.94	80 000	0.175	0.167	1.400	0.866	0.831	296	105	3 242	0.993	0.559	1.552
1.750	3.14	80 000	0.188	0.180	1.374	0.923	0.888	316	113	3 405	0.957	0.595	1.552
1.750	3.17	80 000	0.190	0.182	1.370	0.931	0.897	319	115	3 429	0.951	0.601	1.552
1.750	1.80	90 000	0.102	0.097	1.546	0.528	0.504	202	69	2 415	1.211	0.341	1.552
1.750	1.91	90 000	0.109	0.104	1.532	0.562	0.538	215	74	2 549	1.189	0.363	1.552
1.750	2.17	90 000	0.125	0.117	1.500	0.638	0.600	240	83	2 843	1.140	0.412	1.552
1.750	2.31	90 000	0.134	0.126	1.482	0.680	0.643	257	89	3 000	1.113	0.439	1.552
1.750	2.66	90 000	0.156	0.148	1.438	0.781	0.745	298	105	3 361	1.048	0.504	1.552
1.750	2.94	90 000	0.175	0.167	1.400	0.866	0.831	332	118	3 647	0.993	0.559	1.552
1.750	3.17	90 000	0.190	0.182	1.370	0.931	0.897	359	129	3 858	0.951	0.601	1.552
1.750	1.68	100 000	0.095	0.090	1.560	0.494	0.469	209	71	2 530	1.233	0.319	1.552
1.750	1.91	100 000	0.109	0.104	1.532	0.562	0.538	239	82	2 833	1.189	0.363	1.552
1.750	2.17	100 000	0.125	0.117	1.500	0.638	0.600	267	92	3 159	1.140	0.412	1.552
1.750	2.31	100 000	0.134	0.126	1.482	0.680	0.643	286	99	3 334	1.113	0.439	1.552
1.750	2.66	100 000	0.156	0.148	1.438	0.781	0.745	331	117	3 735	1.048	0.504	1.552
1.750	2.94	100 000	0.175	0.167	1.400	0.866	0.831	369	132	4 053	0.993	0.559	1.552
1.750	3.14	100 000	0.188	0.180	1.374	0.923	0.888	395	142	4 256	0.957	0.595	1.552
2.000	2.20	70 000	0.109	0.104	1.782	0.648	0.619	193	50	2 652	1.609	0.418	2.027
2.000	2.50	70 000	0.125	0.117	1.750	0.736	0.692	216	56	2 968	1.552	0.475	2.027
2.000	2.67	70 000	0.134	0.126	1.732	0.786	0.742	231	61	3 138	1.520	0.507	2.027
2.000	3.07	70 000	0.156	0.148	1.688	0.904	0.861	268	71	3 533	1.444	0.583	2.027
2.000	3.41	70 000	0.175	0.167	1.650	1.003	0.962	299	81	3 850	1.380	0.647	2.027
2.000	3.64	70 000	0.188	0.180	1.624	1.070	1.029	320	87	4 054	1.336	0.690	2.027
2.000	3.67	70 000	0.190	0.182	1.620	1.080	1.039	324	88	4 085	1.330	0.697	2.027
2.000	3.90	70 000	0.203	0.195	1.594	1.146	1.106	344	94	4 279	1.287	0.739	2.027
2.000	2.20	80 000	0.109	0.104	1.782	0.648	0.619	220	57	3 031	1.609	0.418	2.027
2.000	2.50	80 000	0.125	0.117	1.750	0.736	0.692	246	65	3 392	1.552	0.475	2.027

kN x 0.225 = kip MPa x 145 = psi N.m x 0.738 = lb.ft l/m x 0.0805 = gal/ft l/m x 0.00192 = bb/ft

GEOMETRICAL CHARACTERISTICS AND MECHANICAL PROPERTIES OF COILED TUBING (continued)

Coiled tubing dimensions and specifications						Calculated coiled tubing performance properties							
Outside diameter (in)	Body weight (lb/ft)	Yield strength (psi)	Wall thickness (in)		Inside diameter (in)	Tube area (in ²)		Tension yield (kN)	Internal yield (MPa)	Torsional yield (N.m)	Capacity (l/m)	Wall displacement (l/m)	External displacement (l/m)
			Nominal	Minimum		Nominal	Minimum						
2.000	2.67	80 000	0.134	0.126	1.732	0.786	0.742	264	69	3 587	1 520	0 507	2 027
2.000	3.07	80 000	0.156	0.148	1.688	0.904	0.861	306	82	4 038	1 444	0 583	2 027
2.000	3.41	80 000	0.175	0.167	1.650	1.003	0.962	342	92	4 400	1 380	0 647	2 027
2.000	3.64	80 000	0.188	0.180	1.624	1.070	1.029	366	99	4 634	1 336	0 690	2 027
2.000	3.67	80 000	0.190	0.182	1.620	1.080	1.039	370	100	4 669	1 330	0 697	2 027
2.000	3.90	80 000	0.203	0.195	1.594	1.146	1.106	393	108	4 890	1 287	0 739	2 027
2.000	2.20	90 000	0.109	0.104	1.782	0.648	0.619	248	65	3 410	1 609	0 418	2 027
2.000	2.50	90 000	0.125	0.117	1.750	0.736	0.692	277	73	3 816	1 552	0 475	2 027
2.000	2.67	90 000	0.134	0.126	1.732	0.786	0.742	297	78	4 035	1 520	0 507	2 027
2.000	3.07	90 000	0.156	0.148	1.688	0.904	0.861	345	92	4 543	1 444	0 583	2 027
2.000	3.41	90 000	0.175	0.167	1.650	1.003	0.962	385	104	4 950	1 380	0 647	2 027
2.000	3.67	90 000	0.190	0.182	1.620	1.080	1.039	416	113	5 252	1 330	0 697	2 027
2.000	2.20	100 000	0.109	0.104	1.782	0.648	0.619	276	72	3 789	1 609	0 418	2 027
2.000	2.50	100 000	0.125	0.117	1.750	0.736	0.692	308	81	4 240	1 552	0 475	2 027
2.000	2.67	100 000	0.134	0.126	1.732	0.786	0.742	330	87	4 484	1 520	0 507	2 027
2.000	3.07	100 000	0.156	0.148	1.688	0.904	0.861	383	102	5 047	1 444	0 583	2 027
2.000	3.41	100 000	0.175	0.167	1.650	1.003	0.962	428	115	5 500	1 380	0 647	2 027
2.000	3.64	100 000	0.188	0.180	1.624	1.070	1.029	458	124	5 792	1 336	0 690	2 027
2.000	3.90	100 000	0.203	0.195	1.594	1.146	1.106	492	134	6 112	1 287	0 739	2 027
2.375	2.64	70 000	0.109	0.104	2.157	0.776	0.742	231	42	3 839	2 358	0 501	2 858
2.375	3.00	70 000	0.125	0.117	2.125	0.884	0.830	258	48	4 313	2 288	0 570	2 858
2.375	3.21	70 000	0.134	0.126	2.107	0.943	0.890	277	51	4 571	2 250	0 609	2 858
2.375	3.70	70 000	0.156	0.148	2.063	1.088	1.035	322	60	5 173	2 157	0 702	2 858
2.375	4.11	70 000	0.175	0.167	2.025	1.210	1.158	361	68	5 663	2 078	0 780	2 858
2.375	4.39	70 000	0.188	0.180	1.999	1.292	1.241	386	73	5 983	2 025	0 833	2 858
2.375	4.43	70 000	0.190	0.182	1.995	1.304	1.254	390	74	6 031	2 017	0 841	2 858
2.375	4.71	70 000	0.203	0.195	1.969	1.385	1.335	416	79	6 337	1 964	0 894	2 858
2.375	2.64	80 000	0.109	0.104	2.157	0.776	0.742	264	48	4 387	2 358	0 501	2 858
2.375	3.00	80 000	0.125	0.117	2.125	0.884	0.830	295	54	4 929	2 288	0 570	2 858
2.375	3.21	80 000	0.134	0.126	2.107	0.943	0.890	317	59	5 224	2 250	0 609	2 858
2.375	3.70	80 000	0.156	0.148	2.063	1.088	1.035	368	68	5 912	2 157	0 702	2 858
2.375	4.11	80 000	0.175	0.167	2.025	1.210	1.158	412	78	6 472	2 078	0 780	2 858
2.375	4.39	80 000	0.188	0.180	1.999	1.292	1.241	442	84	6 838	2 025	0 833	2 858
2.375	4.43	80 000	0.190	0.182	1.995	1.304	1.254	446	85	6 893	2 017	0 841	2 858
2.375	4.71	80 000	0.203	0.195	1.969	1.385	1.335	475	91	7 242	1 964	0 894	2 858

kN x 0.225 = kip MPa x 145 = psi N.m x 0.738 = lb.ft l/m x 0.0805 = gal/ft l/m x 0.00192 = bb/ft

GEOMETRICAL CHARACTERISTICS AND MECHANICAL PROPERTIES OF COILED TUBING (continued)

Coiled tubing dimensions and specifications						Calculated coiled tubing performance properties							
Outside diameter (in)	Body weight (lb/ft)	Yield strength (psi)	Wall thickness		Inside diameter (in)	Tube area		Tension yield (kN)	Internal yield (MPa)	Torsional yield (N.m)	Capacity (l/m)	Wall displacement (l/m)	External displacement (l/m)
			Nominal (in)	Minimum (in)		Nominal (in ²)	Minimum (in ²)						
2.375	3.00	90 000	0.125	0.117	2.125	0.884	0.830	332	61	5 546	2.288	0.570	2.858
2.375	3.21	90 000	0.134	0.126	2.107	0.943	0.890	356	66	5 877	2.250	0.609	2.858
2.375	3.70	90 000	0.156	0.148	2.063	1.088	1.035	415	77	6 651	2.157	0.702	2.858
2.375	4.11	90 000	0.175	0.167	2.025	1.210	1.158	464	87	7 281	2.078	0.780	2.858
2.375	4.43	90 000	0.190	0.182	1.995	1.304	1.254	502	95	7 754	2.017	0.841	2.858
2.375	4.73	90 000	0.204	0.196	1.967	1.391	1.342	537	102	8 177	1.960	0.898	2.858
2.375	2.64	100 000	0.109	0.104	2.157	0.776	0.742	330	60	5 484	2.358	0.501	2.858
2.375	3.00	100 000	0.125	0.117	2.125	0.884	0.830	369	68	6 162	2.288	0.570	2.858
2.375	3.21	100 000	0.134	0.126	2.107	0.943	0.890	396	73	6 530	2.250	0.609	2.858
2.375	3.70	100 000	0.156	0.148	2.063	1.088	1.035	461	86	7 390	2.157	0.702	2.858
2.375	4.11	100 000	0.175	0.167	2.025	1.210	1.158	515	97	8 090	2.078	0.780	2.858
2.375	4.39	100 000	0.188	0.180	1.999	1.292	1.241	552	105	8 547	2.025	0.833	2.858
2.375	4.71	100 000	0.203	0.195	1.969	1.385	1.335	594	113	9 052	1.964	0.894	2.858
2.875	3.67	70 000	0.125	0.117	2.625	1.080	1.014	316	39	6 499	3.492	0.697	4.188
2.875	3.92	70 000	0.134	0.126	2.607	1.154	1.088	339	42	6 901	3.444	0.744	4.188
2.875	4.53	70 000	0.156	0.148	2.563	1.333	1.268	395	50	7 849	3.329	0.860	4.188
2.875	5.05	70 000	0.175	0.167	2.525	1.484	1.421	442	56	8 630	3.231	0.958	4.188
2.875	5.40	70 000	0.188	0.180	2.499	1.587	1.524	475	60	9 144	3.164	1.024	4.188
2.875	5.45	70 000	0.190	0.182	2.495	1.603	1.540	479	61	9 221	3.154	1.034	4.188
2.875	5.79	70 000	0.203	0.195	2.469	1.704	1.642	511	65	9 717	3.089	1.099	4.188
2.875	3.67	80 000	0.125	0.117	2.625	1.080	1.014	361	45	7 427	3.492	0.697	4.188
2.875	3.92	80 000	0.134	0.126	2.607	1.154	1.088	387	48	7 887	3.444	0.744	4.188
2.875	4.53	80 000	0.156	0.148	2.563	1.333	1.268	451	57	8 970	3.329	0.860	4.188
2.875	5.05	80 000	0.175	0.167	2.525	1.484	1.421	506	64	9 862	3.231	0.958	4.188
2.875	5.40	80 000	0.188	0.180	2.499	1.587	1.524	542	69	10 450	3.164	1.024	4.188
2.875	5.45	80 000	0.190	0.182	2.495	1.603	1.540	548	70	10 539	3.154	1.034	4.188
2.875	5.79	80 000	0.203	0.195	2.469	1.704	1.642	584	75	11 105	3.089	1.099	4.188
2.875	3.92	90 000	0.134	0.126	2.607	1.154	1.088	436	54	8 873	3.444	0.744	4.188
2.875	4.53	90 000	0.156	0.148	2.563	1.333	1.268	508	64	10 092	3.329	0.860	4.188
2.875	5.05	90 000	0.175	0.167	2.525	1.484	1.421	569	72	11 095	3.231	0.958	4.188
2.875	5.45	90 000	0.190	0.182	2.495	1.603	1.540	616	79	11 856	3.154	1.034	4.188
2.875	5.82	90 000	0.204	0.196	2.467	1.712	1.650	660	85	12 542	3.084	1.104	4.188
2.875	6.34	90 000	0.224	0.216	2.427	1.866	1.804	722	93	13 482	2.985	1.204	4.188
2.875	3.67	100 000	0.125	0.117	2.625	1.080	1.014	451	56	9 284	3.492	0.697	4.188
2.875	3.92	100 000	0.134	0.126	2.607	1.154	1.088	484	60	9 858	3.444	0.744	4.188
2.875	4.53	100 000	0.156	0.148	2.563	1.333	1.268	564	71	11 213	3.329	0.860	4.188

kN x 0.225 = kip MPa x 145 = psi N.m x 0.738 = lb.ft l/m x 0.0805 = gal/ft l/m x 0.00192 = bb/ft

GEOMETRICAL CHARACTERISTICS AND MECHANICAL PROPERTIES OF COILED TUBING (continued)

Coiled tubing dimensions and specifications						Calculated coiled tubing performance properties							
Outside diameter (in)	Body weight (lb/ft)	Yield strength (psi)	Wall thickness (in)		Inside diameter (in)	Tube area (in ²)		Tension yield (kN)	Internal yield (MPa)	Torsional yield (N.m)	Capacity (l/m)	Wall displacement (l/m)	External displacement (l/m)
			Nominal	Minimum		Nominal	Minimum						
2.875	5.05	100 000	0.175	0.167	2.525	1.484	1.421	632	80	12 328	3.231	0.958	4.188
2.875	5.40	100 000	0.188	0.180	2.499	1.587	1.524	678	86	13 062	3.164	1.024	4.188
2.875	5.79	100 000	0.203	0.195	2.469	1.704	1.642	730	94	13 882	3.089	1.099	4.188
3.500	4.82	70 000	0.134	0.126	3.232	1.417	1.336	416	35	10 489	5.293	0.914	6.207
3.500	5.57	70 000	0.156	0.148	3.188	1.639	1.559	485	41	11 981	5.150	1.057	6.207
3.500	6.21	70 000	0.175	0.167	3.150	1.828	1.749	544	46	13 220	5.028	1.179	6.207
3.500	6.65	70 000	0.188	0.180	3.124	1.956	1.877	585	50	14 042	4.945	1.262	6.207
3.500	6.72	70 000	0.190	0.182	3.120	1.976	1.897	591	50	14 167	4.932	1.275	6.207
3.500	7.15	70 000	0.203	0.195	3.094	2.103	2.025	630	54	14 966	4.851	1.357	6.207
3.500	7.18	70 000	0.204	0.196	3.092	2.112	2.034	633	54	15 027	4.844	1.363	6.207
3.500	7.84	70 000	0.224	0.216	3.052	2.305	2.228	694	60	16 215	4.720	1.487	6.207
3.500	4.82	80 000	0.134	0.126	3.232	1.417	1.336	475	40	11 988	5.293	0.914	6.207
3.500	5.57	80 000	0.156	0.148	3.188	1.639	1.559	555	47	13 692	5.150	1.057	6.207
3.500	6.21	80 000	0.175	0.167	3.150	1.828	1.749	622	53	15 108	5.028	1.179	6.207
3.500	6.65	80 000	0.188	0.180	3.124	1.956	1.877	668	57	16 048	4.945	1.262	6.207
3.500	6.72	80 000	0.190	0.182	3.120	1.976	1.897	675	57	16 191	4.932	1.275	6.207
3.500	7.15	80 000	0.203	0.195	3.094	2.103	2.025	720	61	17 104	4.851	1.357	6.207
3.500	7.18	80 000	0.204	0.196	3.092	2.112	2.034	724	62	17 173	4.844	1.363	6.207
3.500	7.84	80 000	0.224	0.216	3.052	2.305	2.228	793	68	18 531	4.720	1.487	6.207
3.500	4.82	90 000	0.134	0.126	3.232	1.417	1.336	535	45	13 486	5.293	0.914	6.207
3.500	5.57	90 000	0.156	0.148	3.188	1.639	1.559	624	52	15 404	5.150	1.057	6.207
3.500	6.21	90 000	0.175	0.167	3.150	1.828	1.749	700	59	16 997	5.028	1.179	6.207
3.500	6.72	90 000	0.190	0.182	3.120	1.976	1.897	759	65	18 215	4.932	1.275	6.207
3.500	7.18	90 000	0.204	0.196	3.092	2.112	2.034	814	69	19 320	4.844	1.363	6.207
3.500	7.84	90 000	0.224	0.216	3.052	2.305	2.228	892	77	20 848	4.720	1.487	6.207
3.500	4.82	100 000	0.134	0.126	3.232	1.417	1.336	594	50	14 985	5.293	0.914	6.207
3.500	5.57	100 000	0.156	0.148	3.188	1.639	1.559	693	58	17 115	5.150	1.057	6.207
3.500	6.21	100 000	0.175	0.167	3.150	1.828	1.749	778	66	18 885	5.028	1.179	6.207
3.500	6.65	100 000	0.188	0.180	3.124	1.956	1.877	835	71	20 060	4.945	1.262	6.207
3.500	7.15	100 000	0.203	0.195	3.094	2.103	2.025	901	77	21 380	4.851	1.357	6.207
4.500	8.75	70 000	0.190	0.182	4.120	2.573	2.469	769	39	24 294	8.601	1.660	10.261
4.500	9.36	70 000	0.204	0.196	4.092	2.753	2.650	825	42	25 838	8.485	1.776	10.261
4.500	10.23	70 000	0.224	0.216	4.052	3.009	2.907	905	46	27 991	8.319	1.941	10.261
4.500	11.35	70 000	0.250	0.242	4.000	3.338	3.237	1 008	52	30 695	8.107	2.154	10.261

kN x 0.225 = kip MPa x 145 = psi N.m x 0.738 = lb.ft l/m x 0.0805 = gal/ft l/m x 0.00192 = bbl/ft

GEOMETRICAL CHARACTERISTICS AND MECHANICAL PROPERTIES OF COILED TUBING (continued)

Coiled tubing dimensions and specifications						Calculated coiled tubing performance properties							
Outside diameter (in)	Body weight (lb/ft)	Yield strength (psi)	Wall thickness		Inside diameter (in)	Tube area		Tension yield (kN)	Internal yield (MPa)	Torsional yield (N.m)	Capacity (l/m)	Wall displacement (l/m)	External displacement (l/m)
			Nominal (in)	Minimum (in)		Nominal (in ²)	Minimum (in ²)						
4.500	8.75	80 000	0.190	0.182	4.120	2.573	2.469	879	45	27 764	8.601	1.660	10.261
4.500	9.36	80 000	0.204	0.196	4.092	2.753	2.650	943	48	29 530	8.485	1.776	10.261
4.500	10.23	80 000	0.224	0.216	4.052	3.009	2.907	1 034	53	31 990	8.319	1.941	10.261
4.500	11.35	80 000	0.250	0.242	4.000	3.338	3.237	1 152	59	35 080	8.107	2.154	10.261
4.500	8.75	90 000	0.190	0.182	4.120	2.573	2.469	988	50	31 235	8.601	1.660	10.261
4.500	9.36	90 000	0.204	0.196	4.092	2.753	2.650	1 061	54	33 221	8.485	1.776	10.261
4.500	10.23	90 000	0.224	0.216	4.052	3.009	2.907	1 164	60	35 988	8.319	1.941	10.261
4.500	11.35	90 000	0.250	0.242	4.000	3.338	3.237	1 296	67	39 465	8.107	2.154	10.261
5.000	11.43	70 000	0.224	0.216	4.552	3.361	3.246	1 011	42	35 083	10.499	2.168	12.668
5.000	12.68	70 000	0.250	0.242	4.500	3.731	3.617	1 126	47	38 542	10.261	2.407	12.668
5.000	11.43	80 000	0.224	0.216	4.552	3.361	3.246	1 155	48	40 095	10.499	2.168	12.668
5.000	12.68	80 000	0.250	0.242	4.500	3.731	3.617	1 287	53	44 048	10.261	2.407	12.668

kN x 0.225 = kip MPa x 145 = psi N.m x 0.738 = lb.ft l/m x 0.0805 = gal/ft l/m x 0.00192 = bbl/ft

GEOMETRIC CHARACTERISTICS AND MECHANICAL PROPERTIES OF LINE PIPE, RISER AND CONDUCTOR PIPE

Outside diameter (in) (mm)	22 558.8				24 609.6				26 660.4							
	9.53 0.375	12.70 0.500	19.05 0.750	12.70 0.500	15.88 0.625	19.05 0.750	25.40 1.000	12.70 0.500	15.88 0.625	19.05 0.750	25.40 1.000	12.70 0.500	15.88 0.625	19.05 0.750	25.40 1.000	
Wall thickness (mm) (in)	539.8 21.25	533.4 21.00	520.7 20.50	584.2 23.00	577.9 22.75	571.5 22.50	558.8 22.00	635.0 25.00	628.7 24.75	622.3 24.50	609.6 24.00	635.0 25.00	628.7 24.75	622.3 24.50	609.6 24.00	
Inside diameter (mm) (in)	164.4 25.5	217.9 33.8	323.0 50.1	238.2 36.9	296.1 45.9	353.4 54.8	466.2 72.3	258.4 40.1	321.4 49.8	383.8 59.5	506.7 78.5	258.4 40.1	321.4 49.8	383.8 59.5	506.7 78.5	
Cross section area (cm ²) (in ²)	126.6 86.7	167.8 115.0	248.8 170.5	183.4 125.7	228.0 156.2	272.2 186.5	359.0 246.0	199.0 136.4	247.5 169.6	295.6 202.5	390.2 267.4	199.0 136.4	247.5 169.6	295.6 202.5	390.2 267.4	
Weight (daN/m) (lb/ft)	245.2 2.64	245.2 2.64	245.2 2.64	291.9 3.14	291.9 3.14	291.9 3.14	291.9 3.14	342.5 3.69	342.5 3.69	342.5 3.69	342.5 3.69	342.5 3.69	342.5 3.69	342.5 3.69	342.5 3.69	
Displacement closed-end (l/m) (ft ³ /ft)	228.8 2.47	223.5 2.41	212.9 2.30	268.0 2.89	262.3 2.83	256.5 2.77	245.2 2.65	316.7 3.42	310.4 3.35	304.2 3.28	291.9 3.15	316.7 3.42	310.4 3.35	304.2 3.28	291.9 3.15	
Capacity (l/m) (ft ³ /ft)	228.8 2.47	223.5 2.41	212.9 2.30	268.0 2.89	262.3 2.83	256.5 2.77	245.2 2.65	316.7 3.42	310.4 3.35	304.2 3.28	291.9 3.15	316.7 3.42	310.4 3.35	304.2 3.28	291.9 3.15	
Steel grade	B	X52	B	X52	B	X52	B	X52	B	X52	B	X52	B	X52	B	
Collapse resistance (1) (MPa) (psi)	1.65 239	4.0 580	4.0 580	3.0 435	5.1 740	6.0 870	7.7 1117	9.4 1363	12.8 1856	16.8 2436	19.05 2749	25.40 3658	4.1 595	6.5 943	7.7 1117	11.2 1624
Yield strength (1) (1000 daN) (1000 lb)	397 892	526 1182	781 1756	575 1292	715 1606	1062 2387	853 1917	1267 2849	1125 2529	1671 3757	2082 4654	2540 5658	4.1 595	6.5 943	7.7 1117	11.2 1624
Standard test pressure (2) (MPa) (psi)	6.1 890	8.2 1190	14.7 2130	7.5 1090	9.4 1370	15.9 2300	11.3 1640	15.9 2300	15.1 2190	15.9 2300	15.9 2300	15.9 2300	8.7 1260	10.4 1510	13.8 2000	13.8 2000

(1) Collapse resistance and yield strength are calculated according to API 5C3.

(2) Standard test pressures are API pressures calculated taking stress equal to 75% of the specified minimum yield strength for grade B and 90% for Grade X52 (API Standard 5L).

GEOMETRIC CHARACTERISTICS AND MECHANICAL PROPERTIES OF LINE PIPE, RISER AND CONDUCTOR PIPE (continued)

Outside diameter (in) (mm)	30 762.0				32 812.8				36 914.4			
	Wall thickness (mm) (in)	12.70 0.500	15.88 0.625	19.05 0.750	25.40 1.000	12.70 0.500	15.88 0.625	19.05 0.750	25.40 1.000	12.70 0.500	15.88 0.625	19.05 0.750
Inside diameter (mm) (in)	736.6 29.00	730.3 28.75	723.9 28.50	711.2 28.00	787.4 31.00	781.1 30.75	774.7 30.50	762.0 30.00	889.0 35.00	882.7 34.75	876.3 34.50	863.6 34.00
Cross section area (cm ²) (in ²)	299.0 46.3	372.1 57.7	444.6 68.9	587.8 91.1	319.2 49.5	397.4 61.6	475.0 73.6	628.3 97.4	359.8 55.8	448.1 69.5	535.8 83.1	709.4 110.0
Weight (daN/m) (lb/ft)	230.2 157.8	286.6 196.4	342.4 234.6	452.6 310.2	245.8 168.4	306.1 209.7	365.8 250.7	483.9 331.5	277.0 189.8	345.1 236.5	412.6 282.8	546.3 374.3
Displacement closed-end (l/m) (ft ³ /ft)	456.0 4.91	456.0 4.91	456.0 4.91	456.0 4.91	518.9 5.59	518.9 5.59	518.9 5.59	518.9 5.59	656.7 7.07	656.7 7.07	656.7 7.07	656.7 7.07
Capacity (l/m) (ft ³ /ft)	426.1 4.60	418.8 4.52	411.6 4.44	397.3 4.29	486.9 5.26	479.1 5.17	471.4 5.09	456.0 4.92	620.7 6.70	611.9 6.60	603.1 6.51	585.8 6.32
Steel grade	B	X52	B	X52	B	X52	B	X52	B	X52	B	X52
Collapse resistance (1) (MPa) (psi)	1.5 218	3.0 435	4.6 667	8.7 1262	1.3 189	2.5 363	4.4 638	7.7 1120	0.9 131	1.8 261	3.0 435	6.0 870
Yield strength (1) (1000 daN) (1000 lb)	721 1622	898 2019	1073 2412	1418 3189	770 1732	959 2156	1146 2577	1516 3409	868 1952	1081 2431	1293 2907	1712 3848
Standard test pressure (2) (MPa) (psi)	6.1 880	7.5 1090	9.0 1310	12.1 1750	5.7 820	7.1 1030	8.5 1230	11.3 1640	5.0 730	6.3 910	7.5 1090	10.1 1460

(1) Collapse resistance and yield strength are calculated according to API 5C3.

(2) Standard test pressures are API pressures calculated taking stress equal to 75% of the specified minimum yield strength for grade B and 90% for Grade X52 (API Standard 5L).

GEOMETRIC CHARACTERISTICS AND MECHANICAL PROPERTIES OF LINE PIPE, RISER AND CONDUCTOR PIPE (continued)

Outside diameter (in) (mm)	40 1016.0				42 1066.8			
	12.70 0.500	15.88 0.625	19.05 0.750	25.40 1.000	12.70 0.500	15.88 0.625	19.05 0.750	25.40 1.000
Wall thickness (mm) (in)								
Inside diameter (mm) (in)	990.6 39.00	984.3 38.75	977.9 38.50	965.2 38.00	1041 41.00	1035 40.75	1029 40.50	1016 40.00
Cross section area (cm ²) (in ²)	400.3 62.0	498.8 77.3	596.6 92.5	790.5 122.5	420.6 65.2	524.1 81.2	627.0 97.2	831.0 128.8
Weight (daN/m) (lb/ft)	308.3 211.2	384.1 263.2	459.5 314.8	608.7 417.1	323.9 221.9	403.6 276.6	482.9 330.9	639.9 438.5
Displacement closed-end (l/m) (ft ³ /ft)	810.7 8.73	810.7 8.73	810.7 8.73	810.7 8.73	893.8 9.62	893.8 9.62	893.8 9.62	893.8 9.62
Capacity (l/m) (ft ³ /ft)	770.7 8.32	760.9 8.21	751.1 8.11	731.7 7.90	851.8 9.19	841.4 9.08	831.1 8.97	810.7 8.75
Steel grade	B	B	B	B	B	B	B	B
Collapse resistance (1) (MPa) (psi)	0.65 94	1.3 189	2.2 319	4.8 696	0.56 81	1.1 160	1.9 276	4.0 580
Yield strength (1) (1000 daN) (1000 lb)	966 2172	1204 2706	1440 3237	1908 4288	1015 2282	1265 2843	1513 3402	2005 4508
Standard test pressure (2) (MPa) (psi)	4.6 660	5.7 820	6.8 980	9.0 1310	4.3 620	5.4 780	6.5 940	8.6 1250

(1) Collapse resistance and yield strength are calculated according to API 5C3.

(2) Standard test pressures are API pressures calculated taking stress equal to 75% of the specified minimum yield strength for grade B and 90% for Grade X52 (API Standard 5L).

API AND BUTTRESS CASING THREAD FORMS

API round thread form

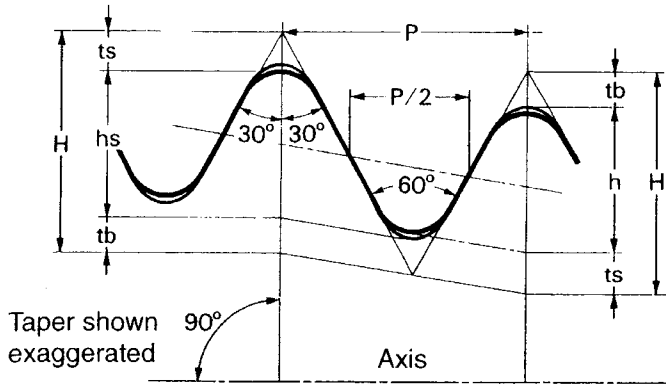

Taper: 6.25%

8 threads/in, $p = 3.175 \text{ mm (1/8 in)}$

$$H = 0.866 p = 2.750 \text{ mm}$$

$$h = 0.626 p - 0.178 = 1.810 \text{ mm}$$

$$tb = 0.120 p + 0.051 = 0.432 \text{ mm}$$

$$ts = 0.120 p + 0.127 = 0.508 \text{ mm}$$

Buttress thread form

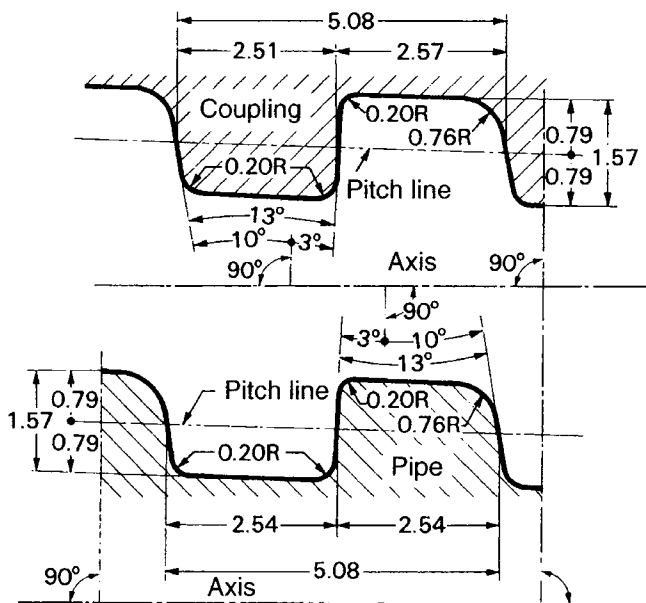

Taper: 6.25%

5 threads/in

Threads crests and roots are parallel to cone.
Dimensions in mm unless otherwise indicated.

API TUBING THREAD FORM

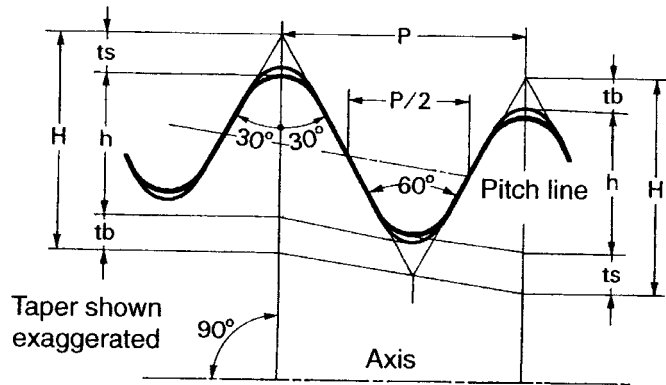

Taper: 6.25%

Thread element	10 threads per inch $\rho = 2.540 \text{ mm (1/10 in)}$	8 threads per inch $\rho = 3.175 \text{ mm (1/8 in)}$
$H = 0.866 \rho$	2.200 mm	2.750 mm
$h = 0.626 \rho - 0.178$	1.412 mm	1.810 mm
$tb = 0.120 \rho + 0.051$	0.356 mm	0.432 mm
$ts = 0.120 \rho + 0.127$	0.432 mm	0.508 mm

OD (in)	Threads per inch		
	Tubing without upset	Tubing with external upset	Tubing with integral joint
1.050	10	10	—
1.315	10	10	10
1.660	10	10	10
1.900	10	10	10
2.063	—	—	10
2 3/8	10	8	—
2 7/8	10	8	—
3 1/2	10	8	—
4	8	8	—
4 1/2	8	8	—

EFFECT OF TENSILE LOAD ON COLLAPSE RESISTANCE

The collapse resistance of casing in the presence of an axial stress is calculated by modifying the yield stress to an axial stress equivalent grade according to formula:

$$Y_{pa} = \left[\sqrt{1 - 0.75 \left(\frac{S_a}{Y_p} \right)^2} - 0.5 \frac{S_a}{Y_p} \right] Y_p$$

where:

S_a = axial stress, psi or MPa (tension is positive)

Y_p = minimum yield strength of the pipe, psi or MPa

Y_{pa} = yield strength of axial stress equivalent grade, psi or MPa

This formula is based on the Hencky-Von Mises maximum strain energy of distortion theory of yielding.

Example of how to use this formula:

Let us assume that 150×10^3 daN of casing are suspended below a 9 5/8 in, 43.50 lb/ft T95 joint. Using the formula, determine the effective collapse resistance of the pipe as a function of the applied load:

Solution: Determine the axial stress:

$$S_a = \frac{\text{Tensile load applied}}{\text{Pipe cross-section area}} = \frac{1\,000\,000}{8\,103 \times 10^{-6}} = 123.4 \text{ MPa}$$

$$S_a = 17\,898 \text{ psi}$$

$$Y_{pa} = \left[\sqrt{1 - 0.75 \left(\frac{17\,898}{95\,000} \right)^2} - 0.5 \frac{17\,898}{95\,000} \right] 95\,000$$

$$Y_{pa} = 84\,778 \text{ psi}$$

The collapse resistance of this 9 5/8 in, 43.50 lb/ft T95 casing under a tensile load of 100×10^3 daN is an intermediate value between the collapse resistance of a LN80 grade casing and a T95 grade casing:

Collapse pressure for LN80 43.50 lb/ft: 26.3 MPa

Collapse pressure for T95 43.50 lb/ft: 28.5 MPa

Approximated collapse pressure for '84 778' grade 43.50 lb/ft is:

$$P_{co} = 26.3 + (28.5 - 26.3) \frac{84\,778 - 80\,000}{95\,000 - 80\,000} = 27.0 \text{ MPa}$$

Note: Exact calculation using API 5C3 formulas gives: 26.7 MPa

ELLIPSE OF BIAXIAL YIELD STRESS

Effect of tensile load on collapse resistance

$$Y_{pa} = \left[\sqrt{1 - 0.75 \left(\frac{S_a}{Y_p} \right)^2} - 0.5 \frac{S_a}{Y_p} \right] Y_p$$

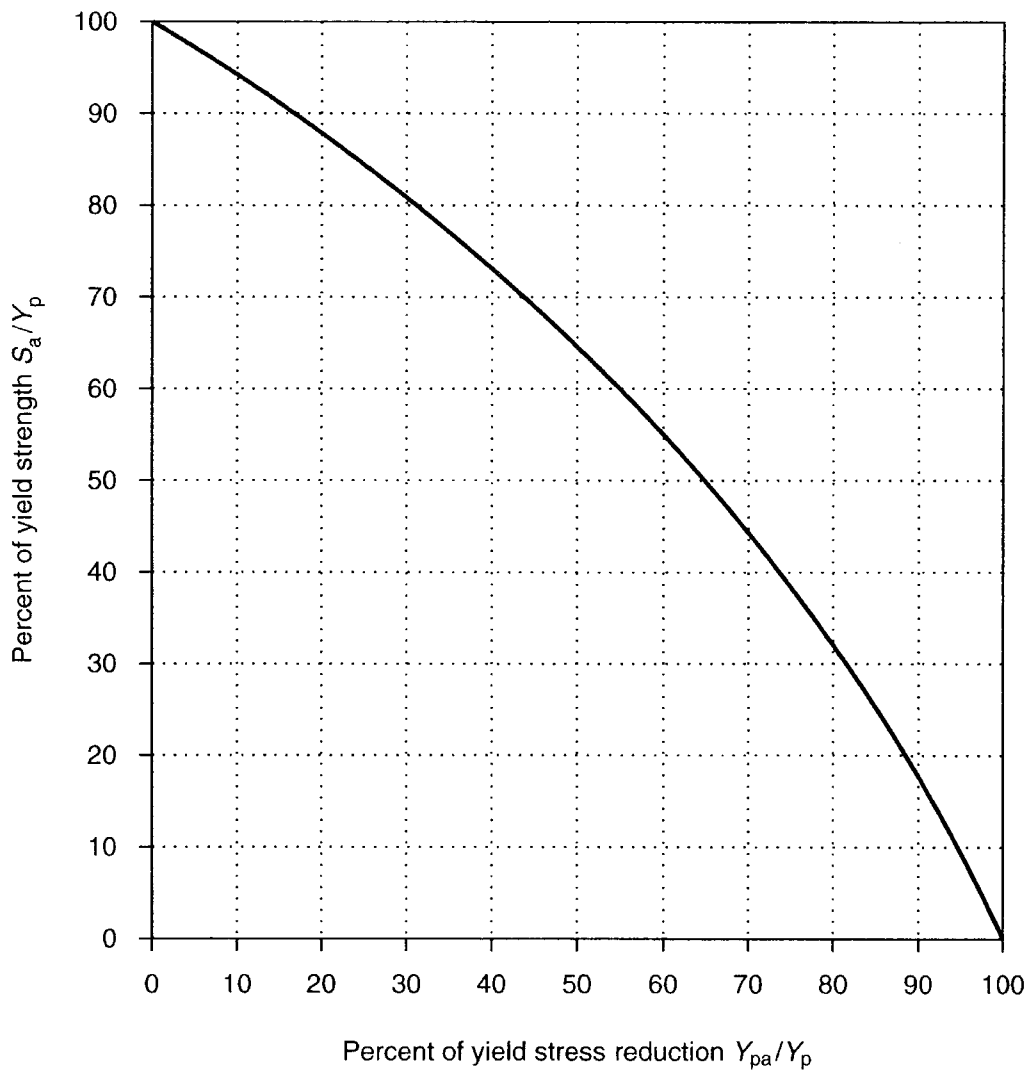

QUALITATIVE INFLUENCE OF VARIOUS OPERATIONS ON THE STRESSES IN A PARTIALLY-CEMENTED CASING STRING

Operations	Tension	Collapse	Bursting	Buckling tendency
Decrease of average temperature	Increases			Decreases
Increase of average temperature	Decreases			Increases
Increase of internal pressure	Increases		Increases	Increases
Decrease of internal pressure	Decreases		Decreases	Decreases
Increase of external pressure	Decreases	Increases		Decreases
Decrease of external pressure	Increases	Decreases		Increases
Substitution of internal fluid by a heavier fluid	Increases		Increases	Increases
Substitution of internal fluid by a lighter fluid	Decreases		Decreases	Decreases
Substitution of external fluid by a heavier fluid	Decreases	Increases		Decreases
Substitution of external fluid by a lighter fluid	Increases	Decreases		Increases
Swabbing	Decreases		Decreases	Decreases

QUANTITATIVE INFLUENCE OF TEMPERATURE AND PRESSURE VARIATIONS ON THE STRESSES IN A PARTIALLY-CEMENTED CASING STRING

Influence of temperature changes

The increase or decrease of the tension at the top of a casing string due to a decrease or increase of the average temperature is given by:

$$T = 25.5 S \Delta t \quad \text{or} \quad T = 32. W \Delta t$$

where:

T = tension variation (daN)

S = cross section of casing (cm²)

W = linear weight of casing (daN/m)

Δt = average temperature variation of casing (°C or K)

The average temperature of the free part of the casing is given by the formula:

$$t = t_0 + \frac{(t_1 - t_0)L_2}{2L_1}$$

with:

t = average temperature of the free part of the casing (°C)

t_0 = surface temperature (°C)

t_1 = bottom hole temperature (°C)

L_1 = depth of the hole (m)

L_2 = depth of top of cement (m)

Influence of internal pressure changes

The increase or decrease of the tension at the top of a casing string due to an increase or decrease of the internal pressure is given by the formula:

$$T = 6 A_i \Delta p_i$$

where:

T = tension variation (daN)

A_i = internal section area of casing (cm²)

Δp_i = variation of internal average pressure (MPa)

Influence of external pressure changes

The increase or decrease of the tension at the top of a casing string due to a decrease or increase of the external pressure is given by the formula:

$$T = 6 A_e \Delta p_e$$

where:

T = tension variation (daN)

A_e = external section area of casing (cm²)

Δp_e = variation of external average pressure (MPa)

QUANTITATIVE INFLUENCE OF TEMPERATURE AND PRESSURE VARIATIONS ON THE STRESSES IN A PARTIALLY-CEMENTED CASING STRING (continued)

If the average internal or external pressure change is due to a change in the mud weight, the average pressure change is given by:

$$\Delta p = 9.81 (d_2 - d_1) \frac{L_2}{2}$$

where:

d_1 = initial mud specific gravity

d_2 = new mud specific gravity

L_2 = depth at the top of cement (m)

Δp = average pressure change (kPa)

Critical buckling force

The critical buckling force is given by:

$$F_c = 10 (P_e A_e - P_i A_i)$$

where:

F_c = critical buckling force (daN)

P_e = annulus pressure at the top of cement (MPa)

P_i = internal pressure at the top of cement (MPa)

A_e = external section area of casing (cm²)

A_i = internal section area of casing (cm²)

If F_c is positive, the string can withstand a maximum compression load at the top of cement equal to F_c without buckling.

If F_c is negative, the string will buckle for a tensile load lower than F_c .

D

capacities and annular volumes

General formulas.....	D1
Clearance between standard bits and casing size.....	D2-D3
Capacities of cylinders.....	D4-D5
Capacities of drill pipes.....	D6-D7
Capacities of drill collars.....	D8
Capacities and displacements of casing.....	D9-D10
Capacities and displacements of tubings.....	D11
Annular volume between drill collar and open hole (liters per meter).....	D12
Annular volume between drill pipe and open hole (liters per meter).....	D13
Annular volume between drill pipe and casing (liters per meter).....	D14-D15
Annular volume between casing and open hole (liters per meter).....	D16
Annular volume between two string of casing (liters per meter).....	D17-D19
Annular volume between casing and tubing (liters per meter).....	D20-D21
Capacities of coiled tubing	D22-D23

GENERAL FORMULAS

Volume of a cylinder

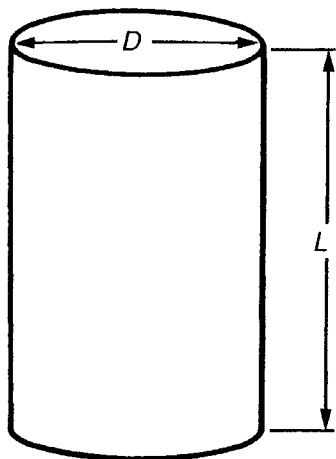

$$V = \frac{\pi}{4} D^2 L$$

Volume in l/m:

$$V = 0.0007854 D^2 \quad (\text{with } D \text{ in mm})$$

$$V = 0.5067 D^2 \quad (\text{with } D \text{ in inches})$$

Approximate formula:

$$V = \frac{D^2}{2} \quad (\text{with } D \text{ in inches})$$

Example:

$$D = 3 \text{ inches}$$

$$= 76.2 \text{ mm}$$

Exact formula: $V = 4.560 \text{ l/m}$

Approximate formula: $V = 4.5 \text{ l/m}$

Volume of an annular space

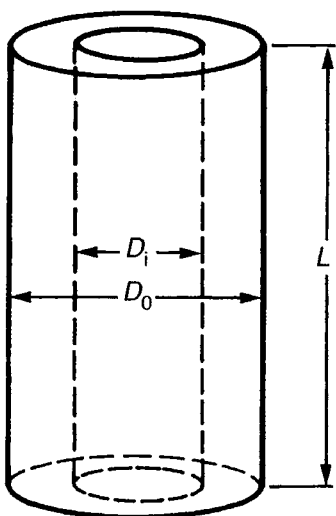

$$V = \frac{\pi}{4} (D_0^2 - D_i^2) L$$

Volume in l/m:

$$V = 0.0007854 (D_0^2 - D_i^2) \quad (\text{with } D_0 \text{ in mm})$$

$$(\text{with } D_i \text{ in mm})$$

$$V = 0.5067 (D_0^2 - D_i^2) \quad (\text{with } D_0 \text{ in inches})$$

$$(\text{with } D_i \text{ in inches})$$

$$\text{l/m} \times 0.0805 = \text{gal/ft} \quad \text{l/m} \times 0.00192 = \text{bbl/ft}$$

CLEARANCE BETWEEN STANDARD BITS AND CASING SIZES

Casing dimensions						Drift (mm)	Bit size (1) immediately below drift		Clearance between bit and casing size (mm)
Outside diameter		Nominal weight		Thickness (mm)	Inside diameter (mm)		(in)	(mm)	
(in)	(mm)	(lb/ft)	(daN/m)						
4 1/2	114.3	9.50	13.86	5.21	103.88	100.71	3 7/8	98.43	5.5
		10.50	15.32	5.69	102.92	99.75	3 7/8	98.43	4.5
		11.60	16.93	6.35	101.60	98.43	3 7/8	98.43	3.2
		13.50	19.70	7.37	99.56	96.39	3 3/4	95.25	4.3
		15.10	22.04	8.56	97.18	94.01	3 5/8	92.08	5.1
		16.90	24.66	9.65	95.00	91.83	3 1/2	88.90	6.1
		17.70	25.83	10.20	93.90	90.73	3 1/2	88.90	5.0
		18.80	27.44	10.92	92.46	89.29	3 1/2	88.90	3.6
5	127.0	11.50	16.78	5.59	115.82	112.65	4 3/8	111.13	4.7
		13.00	18.97	6.43	114.14	110.97	4 1/4	107.95	6.2
		15.00	21.89	7.52	111.96	108.79	4 1/4	107.95	4.0
		18.00	26.27	9.19	108.62	105.45	4 1/8	104.78	3.8
		21.40	31.23	11.10	104.80	101.63	4	101.60	3.2
		23.20	33.86	12.14	102.72	99.54	3 7/8	98.43	4.3
		24.10	35.17	12.70	101.60	98.43	3 7/8	98.43	3.2
		5 1/2	139.7	14.00	20.43	6.20	127.30	124.13	4 7/8
15.50	22.62			6.98	125.74	122.57	4 3/4	120.65	5.1
17.00	24.81			7.72	124.26	121.09	4 3/4	120.65	3.6
20.00	29.19			9.17	121.36	118.19	4 5/8	117.48	3.9
23.00	33.57			10.54	118.62	115.44	4 1/2	114.30	4.3
26.00	37.94			12.09	115.52	112.34	4 3/8	111.13	4.4
26.80	39.11			12.70	114.30	111.13	4 3/8	111.13	3.2
6 5/8	168.3			20.00	29.19	7.32	153.64	150.46	5 7/8
		23.20	33.86	8.38	151.52	148.34	5 3/4	146.05	5.5
		24.00	35.03	8.94	150.40	147.22	5 3/4	146.05	4.3
		28.00	40.86	10.59	147.10	143.92	5 5/8	142.88	4.2
		32.00	46.70	12.07	144.15	140.97	5 1/2	139.70	4.4
		35.00	51.08	13.34	141.60	138.42	5 3/8	136.53	5.1
		7	177.8	17.00	24.81	5.87	166.06	162.89	6 3/8
20.00	29.19			6.91	163.98	160.81	6 1/4	158.75	5.2
23.00	33.57			8.05	161.70	158.53	6 1/8	155.58	6.1
26.00	37.94			9.19	159.42	156.25	6 1/8	155.58	3.8
29.00	42.32			10.36	157.08	153.91	6	152.40	4.7
32.00	46.70			11.51	154.78	151.61	5 7/8	149.23	5.5
35.00	51.08			12.65	152.50	149.33	5 7/8	149.23	3.3
38.00	55.46			13.72	150.36	147.19	5 3/4	146.05	4.3
41.00	59.83			14.98	147.84	144.67	5 5/8	142.88	5.0
44.00	64.21			16.25	145.30	142.13	5 1/2	139.70	5.6
46.00	67.13			17.02	143.76	140.59	5 1/2	139.70	4.1
7 5/8	193.7	24.00	35.03	7.62	178.44	175.26	6 7/8	174.63	3.8
		26.40	38.53	8.33	177.02	173.84	6 3/4	171.45	5.6
		29.70	43.34	9.52	174.64	171.46	6 3/4	171.45	3.2
		33.70	49.18	10.92	171.84	168.66	6 5/8	168.28	3.6
		35.80	52.25	11.81	170.06	166.88	6 1/2	165.10	5.0
		39.00	56.92	12.70	168.28	165.10	6 1/2	165.10	3.2
		42.80	62.46	14.27	165.14	161.96	6 3/8	161.93	3.2
		45.30	66.11	15.11	163.46	160.28	6 1/4	158.75	4.7
		47.10	68.74	15.88	161.92	158.74	6 1/4	158.75	3.2

(1) Drift rounded to the lower 1/8 inch. Not necessarily a size proposed by a bit manufacturer.

mm × 0.0394 = in

CLEARANCE BETWEEN STANDARD BITS AND CASING SIZES (continued)

Casing dimensions						Drift (mm)	Bit size (1) immediately below drift		Clearance between bit and casing size (mm)
Outside diameter		Nominal weight		Thickness (mm)	Inside diameter (mm)		(in)	(mm)	
(in)	(mm)	(lb/ft)	(daN/m)						
8 5/8	219.1	24.00	35.03	6.71	205.66	202.48	7 7/8	200.03	5.6
		28.00	40.86	7.72	203.64	200.46	7 7/8	200.03	3.6
		32.00	46.70	8.94	201.20	198.02	7 3/4	196.85	4.3
		36.00	52.54	10.16	198.76	195.58	7 5/8	193.68	5.1
		40.00	58.38	11.43	196.22	193.04	7 1/2	190.50	5.7
		44.00	64.21	12.70	193.68	190.50	7 1/2	190.50	3.2
		49.00	71.51	14.15	190.78	187.60	7 3/8	187.33	3.4
		52.00	75.89	15.11	188.86	185.68	7 1/4	184.15	4.7
		9 5/8	244.5	32.30	47.14	7.92	228.64	224.67	8 3/4
36.00	52.54			8.94	226.60	222.63	8 3/4	222.25	4.3
40.00	58.38			10.03	224.42	220.45	8 5/8	219.08	5.3
43.50	63.48			11.05	222.38	218.41	8 1/2	215.90	6.5
47.00	68.59			11.99	220.50	216.53	8 1/2	215.90	4.6
53.50	78.08			13.84	216.80	212.83	8 3/8	212.73	4.1
58.40	85.23			15.11	214.26	210.29	8 1/4	209.55	4.7
59.40	86.69			15.47	213.54	209.57	8 1/4	209.55	4.0
61.10	89.17			15.87	212.74	208.77	8 1/8	206.38	6.4
71.80	104.78			19.05	206.38	202.41	7 7/8	200.03	6.4
9 7/8	250.8			62.80	91.65	15.88	219.07	215.10	8 3/8
10 3/4	273.1	32.75	47.80	7.09	258.87	254.90	10	254.00	4.9
		40.50	59.56	8.89	255.27	251.30	9 7/8	250.83	4.4
		45.50	66.91	10.16	252.73	248.76	9 3/4	247.65	5.1
		51.00	75.00	11.43	250.19	246.22	9 5/8	244.48	5.7
		55.50	81.61	12.57	247.91	243.94	9 1/2	241.30	6.6
		60.70	89.26	13.84	245.37	241.40	9 1/2	241.30	4.1
		65.70	95.88	15.11	242.83	238.86	9 3/8	238.13	4.7
		11 3/4	298.5	42.00	61.29	8.46	281.53	277.56	10 7/8
47.00	68.59			9.52	279.41	275.44	10 3/4	273.05	6.4
54.00	78.81			11.05	276.35	272.38	10 5/8	269.88	6.5
60.00	87.56			12.42	273.61	269.64	10 1/2	266.70	6.9
65.00	94.86			13.56	271.33	267.36	10 1/2	266.70	4.6
71.00	103.62			14.78	268.89	264.92	10 3/8	263.53	5.4
13 3/8	339.7			48.00	70.05	8.38	322.97	319.00	12 1/2
		54.50	79.54	9.65	320.43	316.46	12 3/8	314.33	6.1
		61.00	89.02	10.92	317.89	313.92	12 1/4	311.15	6.7
		68.00	99.24	12.19	315.35	311.38	12 1/4	311.15	4.2
		72.00	105.08	13.06	313.61	309.64	12 1/8	307.98	5.6
		77.00	112.37	13.97	311.79	307.82	12	304.80	7.0
		80.70	117.77	14.73	310.27	306.30	12	304.80	5.5
		13 5/8	346.1	88.20	128.72	15.88	314.33	309.57	12 1/8
14	355.6	82.50	120.40	14.27	327.06	322.30	12 5/8	320.68	6.4
		94.80	138.35	16.66	322.28	317.52	12 1/2	317.50	4.8
		99.00	144.48	17.48	320.64	315.88	12 3/8	314.33	6.3
		114.00	166.37	20.32	314.96	310.20	12 1/8	307.98	7.0
16	406.4	65.00	94.86	9.52	387.36	382.60	15	381.00	6.4
		75.00	109.45	11.13	384.14	379.38	14 7/8	377.83	6.3
		84.00	122.59	12.57	381.26	376.50	14 3/4	374.65	6.6
		94.50	137.91	14.27	377.86	373.10	14 5/8	371.48	6.4
		109.00	159.07	16.66	373.08	368.32	14 1/2	368.30	4.8
		128.00	186.80	19.84	366.72	361.96	14 1/4	361.95	4.8
18 5/8	473.1	87.50	127.70	11.05	450.98	446.21	17 1/2	444.50	6.5
20	508.0	94.00	137.18	11.13	485.74	480.98	18 7/8	479.43	6.3
		106.50	155.43	12.70	482.60	477.84	18 3/4	476.25	6.4
		133.00	194.10	16.13	475.74	470.98	18 1/2	469.90	5.8

(1) Drift rounded to the lower 1/8 inch. Not necessarily a size proposed by a bit manufacturer.

mm × 0.0394 = in

CAPACITIES OF CYLINDERS

Diameter (in)	Capacity (l/m)	Diameter (in)	Capacity (l/m)	Diameter (in)	Capacity (l/m)	Diameter (in)	Capacity (l/m)	Diameter (in)	Capacity (l/m)
1	0.507	5	12.67	9	41.04	13	85.63	17	146.4
1 1/8	0.641	5 1/8	13.31	9 1/8	42.19	13 1/8	87.29	17 1/8	148.6
1 1/4	0.792	5 1/4	13.97	9 1/4	43.35	13 1/4	88.96	17 1/4	150.8
1 3/8	0.958	5 3/8	14.64	9 3/8	44.53	13 3/8	90.64	17 3/8	153.0
1 1/2	1.140	5 1/2	15.33	9 1/2	45.73	13 1/2	92.35	17 1/2	155.2
1 5/8	1.338	5 5/8	16.03	9 5/8	46.94	13 5/8	94.06	17 5/8	157.4
1 3/4	1.552	5 3/4	16.75	9 3/4	48.17	13 3/4	95.80	17 3/4	159.6
1 7/8	1.781	5 7/8	17.49	9 7/8	49.41	13 7/8	97.55	17 7/8	161.9
2	2.027	6	18.24	10	50.67	14	99.31	18	164.2
2 1/8	2.288	6 1/8	19.01	10 1/8	51.94	14 1/8	101.1	18 1/8	166.5
2 1/4	2.565	6 1/4	19.79	10 1/4	53.24	14 1/4	102.9	18 1/4	168.8
2 3/8	2.858	6 3/8	20.59	10 3/8	54.54	14 3/8	104.7	18 3/8	171.1
2 1/2	3.167	6 1/2	21.41	10 1/2	55.86	14 1/2	106.5	18 1/2	173.4
2 5/8	3.491	6 5/8	22.24	10 5/8	57.20	14 5/8	108.4	18 5/8	175.8
2 3/4	3.832	6 3/4	23.09	10 3/4	58.56	14 3/4	110.2	18 3/4	178.1
2 7/8	4.188	6 7/8	23.95	10 7/8	59.93	14 7/8	112.1	18 7/8	180.5
3	4.560	7	24.83	11	61.31	15	114.0	19	182.9
3 1/8	4.948	7 1/8	25.72	11 1/8	62.71	15 1/8	115.9	19 1/8	185.3
3 1/4	5.352	7 1/4	26.63	11 1/4	64.13	15 1/4	117.8	19 1/4	187.8
3 3/8	5.772	7 3/8	27.56	11 3/8	65.56	15 3/8	119.8	19 3/8	190.2
3 1/2	6.207	7 1/2	28.50	11 1/2	67.01	15 1/2	121.7	19 1/2	192.7
3 5/8	6.658	7 5/8	29.46	11 5/8	68.48	15 5/8	123.7	19 5/8	195.2
3 3/4	7.125	7 3/4	30.43	11 3/4	69.96	15 3/4	125.7	19 3/4	197.6
3 7/8	7.608	7 7/8	31.42	11 7/8	71.45	15 7/8	127.7	19 7/8	200.2
4	8.107	8	32.43	12	72.96	16	129.7	20	202.7
4 1/8	8.622	8 1/8	33.45	12 1/8	74.49	16 1/8	131.7	20 1/8	205.2
4 1/4	9.152	8 1/4	34.49	12 1/4	76.04	16 1/4	133.8	20 1/4	207.8
4 3/8	9.699	8 3/8	35.54	12 3/8	77.60	16 3/8	135.9	20 3/8	210.4
4 1/2	10.26	8 1/2	36.61	12 1/2	79.17	16 1/2	137.9	20 1/2	212.9
4 5/8	10.84	8 5/8	37.69	12 5/8	80.76	16 5/8	140.0	20 5/8	215.5
4 3/4	11.43	8 3/4	38.79	12 3/4	82.37	16 3/4	142.2	20 3/4	218.2
4 7/8	12.04	8 7/8	39.91	12 7/8	83.99	16 7/8	144.3	20 7/8	220.8

l/m × 0.0805 = gal/ft l/m × 0.00192 = bbl/ft

CAPACITIES OF CYLINDERS (continued)

Diameter (in)	Capacity (l/m)	Diameter (in)	Capacity (l/m)	Diameter (in)	Capacity (l/m)	Diameter (in)	Capacity (l/m)
21	223.5	25	316.7	29	426.1	33	551.8
21 1/8	226.1	25 1/8	319.9	29 1/8	429.8	33 1/8	556.0
21 1/4	228.8	25 1/4	323.1	29 1/4	433.5	33 1/4	560.2
21 3/8	231.5	25 3/8	326.3	29 3/8	437.2	33 3/8	564.4
21 1/2	234.2	25 1/2	329.5	29 1/2	441.0	33 1/2	568.6
21 5/8	237.0	25 5/8	332.7	29 5/8	444.7	33 5/8	572.9
21 3/4	239.7	25 3/4	336.0	29 3/4	448.5	33 3/4	577.2
21 7/8	242.5	25 7/8	339.2	29 7/8	452.2	33 7/8	581.4
22	245.2	26	342.5	30	456.0	34	585.7
22 1/8	248.0	26 1/8	345.8	30 1/8	459.8	34 1/8	590.1
22 1/4	250.8	26 1/4	349.1	30 1/4	463.7	34 1/4	594.4
22 3/8	253.7	26 3/8	352.5	30 3/8	467.5	34 3/8	598.7
22 1/2	256.5	26 1/2	355.8	30 1/2	471.4	34 1/2	603.1
22 5/8	259.4	26 5/8	359.2	30 5/8	475.2	34 5/8	607.5
22 3/4	262.2	26 3/4	362.6	30 3/4	479.1	34 3/4	611.9
22 7/8	265.1	26 7/8	366.0	30 7/8	483.0	34 7/8	616.3
23	268.0	27	369.4	31	486.9	35	620.7
23 1/8	271.0	27 1/8	372.8	31 1/8	490.9	35 1/8	625.1
23 1/4	273.9	27 1/4	376.3	31 1/4	494.8	35 1/4	629.6
23 3/8	279.7	27 3/8	379.7	31 3/8	498.8	35 3/8	634.1
23 1/2	279.8	27 1/2	383.2	31 1/2	502.8	35 1/2	638.6
23 5/8	282.8	27 5/8	386.7	31 5/8	506.8	35 5/8	643.1
23 3/4	285.8	27 3/4	390.2	31 3/4	510.8	35 3/4	647.6
23 7/8	288.8	27 7/8	393.7	31 7/8	514.8	35 7/8	652.1
24	291.9	28	397.3	32	518.9	36	656.7
24 1/8	294.9	28 1/8	400.8	32 1/8	522.9	36 1/8	661.3
24 1/4	298.0	28 1/4	404.4	32 1/4	527.0	36 1/4	665.8
24 3/8	301.1	28 3/8	408.0	32 3/8	531.1	36 3/8	670.4
24 1/2	304.1	28 1/2	411.6	32 1/2	535.2	36 1/2	675.1
24 5/8	307.3	28 5/8	415.2	32 5/8	539.3	36 5/8	679.7
24 3/4	310.4	28 3/4	418.8	32 3/4	543.5	36 3/4	684.3
24 7/8	313.5	28 7/8	422.5	32 7/8	547.6	36 7/8	689.0

l/m \times 0.0805 = gal/ft l/m \times 0.00192 = bbl/ft

CAPACITIES OF DRILL PIPES

Nominal size (in)	Nominal weight (lb/ft)	Upset	Grade	Thread	Tool joint		Volumes (1) (l/m)		
					OD (in)	ID (in)	Metal displacement	Capacity	Total displacement
2 3/8	6.65	EU	E75	NC26(IF)	3 3/8	1 3/4	1.33	1.66	2.99
2 3/8	6.65	EU	X95	NC26(IF)	3 3/8	1 3/4	1.35	1.66	3.01
2 3/8	6.65	EU	G105	NC26(IF)	3 3/8	1 3/4	1.35	1.66	3.01
2 7/8	10.40	EU	E75	NC31(IF)	4 1/8	2 1/8	2.06	2.34	4.41
2 7/8	10.40	EU	X95	NC31(IF)	4 1/8	2	2.10	2.33	4.43
2 7/8	10.40	EU	G105	NC31(IF)	4 1/8	2	2.10	2.33	4.43
2 7/8	10.40	EU	S135	NC31(IF)	4 3/8	1 5/8	2.19	2.29	4.48
3 1/2	9.50	EU	E75	NC38(IF)	4 3/4	2 11/16	2.01	4.49	6.50
3 1/2	9.50	EU	E75	NC38(IF)	4 3/4	3	1.96	4.54	6.50
3 1/2	13.30	EU	E75	NC38(IF)	4 3/4	2 11/16	2.64	3.86	6.50
3 1/2	13.30	EU	X95	NC38(IF)	5	2 9/16	2.77	3.84	6.61
3 1/2	13.30	EU	G105	NC38(IF)	5	2 7/16	2.79	3.82	6.61
3 1/2	13.30	EU	S135	NC38(IF)	5	2 1/8	2.83	3.78	6.61
3 1/2	15.50	EU	E75	NC38(IF)	5	2 9/16	3.14	3.42	6.57
3 1/2	15.50	EU	X95	NC38(IF)	5	2 7/16	3.19	3.41	6.60
3 1/2	15.50	EU	G105	NC38(IF)	5	2 1/8	3.23	3.37	6.60
3 1/2	15.50	EU	S135	NC40(FH)	5 1/2	2 1/4	3.33	3.38	6.72
4	14.00	IU	E75	NC40(FH)	5 1/4	2 13/16	2.85	3.46	6.31
4	14.00	IU	X95	NC40(FH)	5 1/4	2 11/16	2.90	5.55	8.45
4	14.00	IU	G105	NC40(FH)	5 1/2	2 7/16	3.01	5.51	8.52
4	14.00	IU	S135	NC40(FH)	5 1/2	2	3.06	5.46	8.52
4	14.00	EU	E75	NC46(IF)	6	3 1/4	3.01	5.64	8.65
4	14.00	EU	X95	NC46(IF)	6	3 1/4	3.07	5.64	8.71
4	14.00	EU	G105	NC46(IF)	6	3 1/4	3.07	5.64	8.71
4	14.00	EU	S135	NC46(IF)	6	3	3.11	5.59	8.71
4 1/2	13.75	EU	E75	NC50(IF)	6 3/8	3 3/4	2.92	7.89	10.81
4 1/2	13.75	EU	E75	NC50(IF)	6 5/8	3 7/8	2.98	7.92	10.90
4 1/2	16.60	IEU	E75	NC46(XH)	6 1/4	3 1/4	3.48	7.30	10.79
4 1/2	16.60	IEU	X95	NC46(XH)	6 1/4	3	3.53	7.26	10.79
4 1/2	16.60	IEU	G105	NC46(XH)	6 1/4	3	3.53	7.26	10.79
4 1/2	16.60	IEU	S135	NC46(XH)	6 1/4	2 3/4	3.57	7.22	10.79
4 1/2	16.60	IEU	E75	FH	6	3	3.44	7.26	10.70
4 1/2	16.60	IEU	X95	FH	6	3	3.44	7.26	10.71
4 1/2	16.60	IEU	G105	FH	6	3	3.44	7.26	10.71
4 1/2	16.60	IEU	S135	FH	6 1/4	2 1/2	3.61	7.18	10.79
4 1/2	16.60	EU	E75	NC50(IF)	6 3/8	3 3/4	3.41	7.40	10.81
4 1/2	16.60	EU	E75	NC50(IF)	6 5/8	3 3/4	3.50	7.40	10.90
4 1/2	16.60	EU	X95	NC50(IF)	6 3/8	3 3/4	3.48	7.40	10.88
4 1/2	16.60	EU	X95	NC50(IF)	6 5/8	3 3/4	3.57	7.40	10.97
4 1/2	16.60	EU	G105	NC50(IF)	6 3/8	3 3/4	3.48	7.40	10.88
4 1/2	16.60	EU	G105	NC50(IF)	6 5/8	3 3/4	3.57	7.40	10.97
4 1/2	16.60	EU	S135	NC50(IF)	6 3/8	3 1/2	3.53	7.35	10.88
4 1/2	16.60	EU	S135	NC50(IF)	6 5/8	3 1/2	3.62	7.35	10.97
4 1/2	20.00	IEU	E75	NC46(XH)	6 1/4	3	4.19	6.60	10.79
4 1/2	20.00	IEU	X95	NC46(XH)	6 1/4	2 3/4	4.29	6.56	10.84
4 1/2	20.00	IEU	G105	NC46(XH)	6 1/4	2 1/2	4.32	6.52	10.84
4 1/2	20.00	IEU	S135	NC46(XH)	6 1/4	2 1/4	4.36	6.49	10.84

(1) Approximate volumes calculated with the approximate weight (API RP 7G).

l/m × 0.0805 = gal/ft l/m × 0.00192 = bbl/ft

CAPACITIES OF DRILL PIPES (continued)

Nominal size (in)	Nominal weight (lb/ft)	Upset	Grade	Thread	Tool joint		Volumes (1) (l/m)		
					OD (in)	ID (in)	Metal displacement	Capacity	Total displacement
4 1/2	20.00	IEU	E75	FH	6	3	4.11	6.60	10.71
4 1/2	20.00	IEU	X95	FH	6	2 1/2	4.24	6.52	10.76
4 1/2	20.00	IEU	G105	FH	6	2 1/2	4.24	6.52	10.76
4 1/2	20.00	EU	E75	NC50(IF)	6 3/8	3 5/8	4.10	6.71	10.81
4 1/2	20.00	EU	E75	NC50(IF)	6 5/8	3 5/8	4.19	6.71	10.90
4 1/2	20.00	EU	X95	NC50(IF)	6 3/8	3 1/2	4.19	6.69	10.88
4 1/2	20.00	EU	X95	NC50(IF)	6 5/8	3 1/2	4.28	6.69	10.97
4 1/2	20.00	EU	G105	NC50(IF)	6 3/8	3 1/2	4.19	6.69	10.88
4 1/2	20.00	EU	G105	NC50(IF)	6 5/8	3 1/2	4.28	6.69	10.97
4 1/2	20.00	EU	S135	NC50(IF)	6 5/8	3	4.37	6.59	10.97
5	19.50	IEU	E75	NC50(XH)	6 3/8	3 3/4	3.96	9.15	13.11
5	19.50	IEU	E75	NC50(XH)	6 5/8	3 3/4	4.05	9.15	13.19
5	19.50	IEU	X95	NC50(XH)	6 3/8	3 1/2	4.06	9.10	13.16
5	19.50	IEU	X95	NC50(XH)	6 5/8	3 1/2	4.15	9.10	13.24
5	19.50	IEU	G105	NC50(XH)	6 1/2	3 1/4	4.15	9.05	13.20
5	19.50	IEU	G105	NC50(XH)	6 5/8	3 1/4	4.19	9.05	13.24
5	19.50	IEU	S135	NC50(XH)	6 5/8	2 3/4	4.28	8.97	13.24
5	19.50	IEU	E75	5 1/2 FH	7	3 3/4	4.23	9.14	13.37
5	19.50	IEU	X95	5 1/2 FH	7	3 3/4	4.28	9.14	13.42
5	19.50	IEU	G105	5 1/2 FH	7	3 3/4	4.28	9.14	13.42
5	19.50	IEU	S135	5 1/2 FH	7 1/4	3 1/2	4.44	9.08	13.52
5	25.60	IEU	E75	NC50(IF)	6 3/8	3 1/2	5.10	8.01	13.10
5	25.60	IEU	E75	NC50(IF)	6 5/8	3 1/2	5.19	8.00	13.19
5	25.60	IEU	X95	NC50(IF)	6 1/2	3	5.27	7.92	13.19
5	25.60	IEU	X95	NC50(IF)	6 5/8	3	5.32	7.91	13.23
5	25.60	IEU	G105	NC50(IF)	6 5/8	2 3/4	5.36	7.87	13.23
5	25.60	IEU	E75	5 1/2 FH	7	3 1/2	5.37	7.99	13.36
5	25.60	IEU	X95	5 1/2 FH	7	3 1/2	5.41	7.99	13.41
5	25.60	IEU	G105	5 1/2 FH	7 1/4	3 1/2	5.52	7.99	13.51
5	25.60	IEU	S135	5 1/2 FH	7 1/4	3 1/4	5.57	7.94	13.51
5 1/2	21.90	IEU	E75	5 1/2 FH	7	4	4.51	11.37	15.88
5 1/2	21.90	IEU	X95	5 1/2 FH	7	3 3/4	4.63	11.32	15.95
5 1/2	21.90	IEU	G105	5 1/2 FH	7 1/4	3 1/2	4.79	11.26	16.05
5 1/2	21.90	IEU	S135	5 1/2 FH	7 1/2	3	5.00	11.15	16.15
5 1/2	24.70	IEU	E75	5 1/2 FH	7	4	4.99	10.89	15.87
5 1/2	24.70	IEU	X95	5 1/2 FH	7 1/4	3 1/2	5.26	10.77	16.03
5 1/2	24.70	IEU	G105	5 1/2 FH	7 1/4	3 1/2	5.26	10.77	16.03
5 1/2	24.70	IEU	S135	5 1/2 FH	7 1/2	3	5.47	10.67	16.14
6 5/8	25.20	IEU	E75	6 5/8 FH	8	5	5.22	17.72	22.95
6 5/8	25.20	IEU	X95	6 5/8 FH	8	5	5.22	17.72	22.95
6 5/8	25.20	IEU	G105	6 5/8 FH	8 1/4	4 3/4	5.42	17.64	23.07
6 5/8	25.20	IEU	S135	6 5/8 FH	8 1/2	4 1/4	5.69	17.50	23.19
6 5/8	27.70	IEU	E75	6 5/8 FH	8	5	5.57	17.36	22.93
6 5/8	27.70	IEU	X95	6 5/8 FH	8 1/4	4 3/4	5.77	17.28	23.05
6 5/8	27.70	IEU	G105	6 5/8 FH	8 1/4	4 3/4	5.77	17.28	23.05
6 5/8	27.70	IEU	S135	6 5/8 FH	8 1/2	4 1/4	6.04	17.13	23.18

(1) Approximate volumes calculated with the approximate weight (API RP 7G).

l/m × 0.0805 = gal/ft l/m × 0.00192 = bb/ft

CAPACITIES OF DRILL COLLARS (1)

Outside diameter (in)	Total displacement (l/m)	Standard inside diameter (in)	Capacity (l/m)	Optional inside diameter (in)	Capacity (l/m)
3 1/8	4.95	1 1/4	0.79		
3 1/4	5.35	1 1/2	1.14	1 1/4	0.79
3 1/2	6.21	1 1/2	1.14	1 1/4	0.79
3 3/4	7.13	1 1/2	1.14	1 1/4	0.79
4 1/8	8.62	2	2.03	1 3/4	1.55
4 1/4	9.15	2	2.03	1 3/4	1.55
4 1/2	10.26	2	2.03	1 3/4	1.55
4 3/4	11.43	2	2.03	1 3/4	1.55
5	12.67	2 1/4	2.57	1 3/4	1.55
5 1/4	13.97	2 1/4	2.57	1 3/4	1.55
5 1/2	15.33	2 1/4	2.57	1 3/4	1.55
5 3/4	16.75	2 1/4	2.57	2 13/16	4.01
6	18.24	2 1/4	2.57	2 13/16	4.01
6 1/4	19.79	2 1/4	2.57	2 13/16	4.01
6 1/2	21.41	2 1/4	2.57	2 13/16	4.01
6 3/4	23.09	2 1/4	2.57	2 13/16	4.01
7	24.83	2 1/4	2.57	2 13/16	4.01
7 1/4	26.63	2 13/16	4.01	2 1/4	2.57
7 1/2	28.50	2 13/16	4.01	2 1/4	2.57
7 3/4	30.43	2 13/16	4.01	3	4.56
8	32.43	2 13/16	4.01	3	4.56
8 1/4	34.49	2 13/16	4.01	3	4.56
8 1/2	36.61	2 13/16	4.01	3	4.56
8 3/4	38.79	2 13/16	4.01	3	4.56
9	41.04	2 13/16	4.01	3	4.56
9 1/4	43.35	3	4.56	2 13/16	4.01
9 1/2	45.73	3	4.56	2 13/16	4.01
9 3/4	48.17	3	4.56	2 13/16	4.01
10	50.67	3	4.56	2 13/16	4.01
11	61.31	3	4.56	2 13/16	4.01
11 1/4	64.13	3	4.56	2 13/16	4.01

(1) Capacity per meter is calculated on the basis of simple cylinders.

l/m × 0.0805 = gal/ft l/m × 0.00192 = bbl/ft

CAPACITIES AND DISPLACEMENTS OF CASING (1)

OD and total displacement (in and l/m)	Nominal weight (lb/ft)	Thickness (mm)	Capacity (l/m)	OD and total displacement (in and l/m)	Nominal weight (lb/ft)	Thickness (mm)	Capacity (l/m)	
4 1/2 10.26	9.50	5.21	8.48	7 24.83	17.00	5.87	21.66	
	10.50	5.69	8.32		20.00	6.91	21.12	
	11.60	6.35	8.11		23.00	8.05	20.54	
	13.50	7.37	7.79		26.00	9.19	19.96	
	15.10	8.56	7.42		29.00	10.36	19.38	
	16.90	9.65	7.09		32.00	11.51	18.82	
	17.70	10.20	6.92		35.00	12.65	18.27	
	18.80	10.92	6.71		38.00	13.72	17.76	
5 12.67	11.50	5.59	10.54		41.00	14.98	17.17	
	13.00	6.43	10.23		44.00	16.25	16.58	
	15.00	7.52	9.84		46.00	17.02	16.23	
	18.00	9.19	9.27		7 5/8 29.46	24.00	7.62	25.01
	21.40	11.10	8.63			26.40	8.33	24.61
	23.20	12.14	8.29			29.70	9.52	23.95
	24.10	12.70	8.11			33.70	10.92	23.19
5 1/2 15.33	14.00	6.20	12.73			35.80	11.81	22.71
	15.50	6.98	12.42	39.00	12.70	22.24		
	17.00	7.72	12.13	42.80	14.27	21.42		
	20.00	9.17	11.57	45.30	15.11	20.98		
	23.00	10.54	11.05	47.10	15.88	20.59		
	26.00	12.09	10.48	8 5/8 37.69	24.00	6.71	33.22	
26.80	12.70	10.26	28.00		7.72	32.57		
6 5/8 22.24	20.00	7.32	18.54		32.00	8.94	31.79	
	23.20	8.38	18.03		36.00	10.16	31.03	
	24.00	8.94	17.76		40.00	11.43	30.24	
	28.00	10.59	16.99		44.00	12.70	29.46	
	32.00	12.07	16.32		49.00	14.15	28.58	
	35.00	13.34	15.75	52.00	15.11	28.01		

(1) No allowance made for couplings.

mm × 0.0394 = in l/m × 0.0805 = gal/ft l/m × 0.00192 = bbl/ft

CAPACITIES AND DISPLACEMENTS OF CASING (1) (continued)

OD and total displacement (in and l/m)	Nominal weight (lb/ft)	Thickness (mm)	Capacity (l/m)	OD and total displacement (in and l/m)	Nominal weight (lb/ft)	Thickness (mm)	Capacity (l/m)	
9 5/8 46.94	32.30	7.92	41.06	13 3/8 90.64	48.00	8.38	81.92	
	36.00	8.94	40.33		54.50	9.65	80.64	
	40.00	10.03	39.55		61.00	10.92	79.36	
	43.50	11.05	38.84		68.00	12.19	78.10	
	47.00	11.99	38.18		72.00	13.06	77.24	
	53.50	13.84	36.91		77.00	13.97	76.35	
	58.40	15.11	36.05		80.70	14.73	75.60	
	59.40	15.47	35.81		13 5/8 94.06	88.20	15.88	74.49
	61.10	15.87	35.54					
	71.80	19.05	33.45					
9 7/8 49.41	62.80	15.88	45.73	14 99.31	82.50	14.27	76.05	
10 3/4 58.56	32.75	7.09	52.63		94.80	16.66	73.74	
					99.00	17.48	72.95	
				114.00	20.32	70.25		
				16 129.72	65.00	9.52	117.8	
					75.00	11.13	115.9	
84.00	12.57	114.2						
94.50	14.27	112.1						
60.70	13.84	47.29	109.00	16.66	109.3			
65.70	15.11	46.31	128.00	19.84	105.6			
11 3/4 69.96	42.00	8.46	62.25	18 5/8 175.77	87.50	11.05	159.7	
	47.00	9.52	61.32					
	54.00	11.05	59.98	20 202.68	94.00	11.13	185.3	
	60.00	12.42	58.80					
	65.00	13.56	57.82					
71.00	14.78	56.78	106.50	12.70	182.9			
				133.00	16.13	177.8		

(1) No allowance made for couplings.

mm × 0.0394 = in l/m × 0.0805 = gal/ft l/m × 0.00192 = bbl/ft

CAPACITIES AND DISPLACEMENTS OF TUBING (1)

OD and total displacement (in and l/m)	Nominal weight (lb/ft)	Thickness (mm)	Capacity (l/m)	OD and total displacement (in and l/m)	Nominal weight (lb/ft)	Thickness (mm)	Capacity (l/m)
1.050 0.56	1.14/1.20	2.87	0.34	3 1/2 6.21	7.70	5.49	4.77
	1.48/1.54	3.91	0.28		9.20/9.30	6.45	4.54
1.315 0.88	1.70/1.80	3.38	0.56		10.20	7.34	4.33
	2.19/2.24	4.55	0.46		12.70/12.95	9.53	3.83
1.660 1.40	2.10	3.18	1.01		13.70	10.49	3.62
	2.30/2.40	3.56	0.96		14.30	10.92	3.53
	3.03/3.07	4.85	0.83		14.70	11.40	3.43
1.900 1.83	2.4	3.18	1.38		15.50	12.09	3.29
	2.75/2.90	3.68	1.31		17.00	13.46	3.02
	3.65/3.73	5.08	1.14		4 8.11	9.50	5.74
	4.42	6.35	0.99	11.00		6.65	6.12
5.15	7.62	0.86	13.20	8.38		5.65	
2.063 2.16	3.25	3.96	1.55	14.80		9.65	5.32
	4.50	5.72	1.32	16.10	10.54	5.09	
2 3/8 2.86	4.00	4.24	2.11	16.50	10.92	5.00	
	4.60/4.70	4.83	2.02	18.90	12.70	4.56	
	5.10	5.54	1.90	22.20	15.49	3.92	
	5.80/5.90	6.45	1.77	4 1/2 10.26	12.60/12.75	6.88	7.9
	6.60	7.49	1.61		15.20	8.56	7.4
7.35/7.45	8.53	1.47	17.00		9.65	7.1	
2 7/8 4.19	6.40/6.50	5.51	3.02		18.90	10.92	6.7
	7.80/7.90	7.01	2.73		21.50	12.70	6.2
	8.60/8.70	7.82	2.59	23.70	14.22	5.8	
	9.35/9.45	8.64	2.44	26.10	16.00	5.3	
	9.80	9.19	2.35				
	10.50	9.96	2.21				
	11.50	11.18	2.02				

(1) No allowance made for couplings.

mm × 0.0394 = in l/m × 0.0805 = gal/ft l/m × 0.00192 = bbl/ft

ANNULAR VOLUME BETWEEN DRILL COLLAR AND OPEN HOLE (liters per meter)

		Outside diameter of drill collar (in)																			
		0 (1)	3 1/8	3 1/2	4 1/8	4 3/4	5	6	6 1/4	6 1/2	6 3/4	7	7 1/4	7 3/4	8	8 1/4	9	9 1/2	9 3/4	10	11
0 (2)	(l/m)	4.9	6.2	8.6	11.4	12.7	18.2	19.8	21.4	23.1	24.8	26.6	30.4	32.4	34.5	41.0	45.7	48.2	50.7	61.3	
4 3/4	11.4	6.5	5.2	2.8																	
5 7/8	17.5	12.5	11.3	8.9	6.1	4.8															
6	18.2	13.3	12.0	9.6	6.8	5.6															
6 1/8	19.0	14.1	12.8	10.4	7.6	6.3															
6 1/4	19.8	14.8	13.6	11.2	8.4	7.1	1.6														
6 5/8	22.2	17.3	16.0	13.6	10.8	9.6	4.0	2.4													
6 3/4	23.1	18.1	16.9	14.5	11.7	10.4	4.8	3.3	1.7												
7 3/8	27.6	22.6	21.4	18.9	16.1	14.9	9.3	7.8	6.2	4.5	2.7										
7 7/8	31.4	26.5	25.2	22.8	20.0	18.8	13.2	11.6	10.0	8.3	6.6	4.8									
8 3/8	35.5	30.6	29.3	26.9	24.1	22.9	17.3	15.7	14.1	12.5	10.7	8.9	5.1								
8 1/2	36.6	31.7	30.4	28.0	25.2	23.9	18.4	16.8	15.2	13.5	11.8	10.0	6.2	3.1							
8 5/8	37.7	32.7	31.5	29.1	26.3	25.0	19.5	17.9	16.3	14.6	12.9	11.1	7.3	4.2	3.2						
8 3/4	38.8	33.8	32.6	30.2	27.4	26.1	20.6	19.0	17.4	15.7	14.0	12.2	8.4	5.3	4.3						
9	41.0	36.1	34.8	32.4	29.6	28.4	22.8	21.2	19.6	18.0	16.2	14.4	10.6	8.6	6.6						
9 5/8	46.9	42.0	40.7	38.3	35.5	34.3	28.7	27.1	25.5	23.9	22.1	20.3	16.5	14.5	12.5	5.9					
9 7/8	49.4	44.5	43.2	40.8	38.0	36.7	31.2	29.6	28.0	26.3	24.6	22.8	19.0	17.0	14.9	8.4	3.7				
10 5/8	57.2	52.3	51.0	48.6	45.8	44.5	39.0	37.4	35.8	34.1	32.4	30.6	26.8	24.8	22.7	16.2	11.5	9.0	6.5		
12	73.0	68.0	66.8	64.3	61.5	60.3	54.7	53.2	51.6	49.9	48.1	46.3	42.5	40.5	38.5	31.9	27.2	24.8	22.3	11.7	
12 1/4	76.0	71.1	69.8	67.4	64.6	63.4	57.8	56.2	54.6	53.0	51.2	49.4	45.6	43.6	41.5	35.0	30.3	27.9	25.4	14.7	
14 3/4	110.2	105.3	104.0	101.6	98.8	97.6	92.0	90.4	88.8	87.2	85.4	83.6	79.8	77.8	75.8	69.2	64.5	62.1	59.6	48.9	
15	114.0	109.1	107.8	105.4	102.6	101.3	95.8	94.2	92.6	90.9	89.2	87.4	83.6	81.6	79.5	73.0	68.3	65.8	63.3	52.7	
16	129.7	124.8	123.5	121.1	118.3	117.0	111.5	109.9	108.3	106.6	104.9	103.1	99.3	97.3	95.2	88.7	84.0	81.5	79.0	68.4	
17 1/2	155.2	150.2	149.0	146.6	143.7	142.5	136.9	135.4	133.8	132.1	130.3	128.5	124.7	122.7	120.7	114.1	109.4	107.0	104.5	93.9	
20	202.7	197.7	196.5	194.1	191.2	190.0	184.4	182.9	181.3	179.6	177.9	176.0	172.2	170.3	168.2	161.6	157.0	154.5	152.0	141.4	
22	245.2	240.3	239.0	236.6	233.8	232.6	227.0	225.4	223.8	222.2	220.4	218.6	214.8	212.8	210.8	204.2	199.5	197.1	194.6	183.9	
24	291.9	286.9	285.7	283.2	280.4	279.2	273.6	272.1	270.5	268.8	267.0	265.2	261.4	259.4	257.4	250.8	246.1	243.7	241.2	230.5	
26	342.5	337.6	336.3	333.9	331.1	329.9	324.3	322.7	321.1	319.4	317.7	315.9	312.1	310.1	308.0	301.5	296.8	294.4	291.9	281.2	
36	656.7	651.7	650.5	648.1	645.3	644.0	638.4	636.9	635.3	633.6	631.9	630.0	626.2	624.3	622.2	615.6	611.0	608.5	606.0	595.4	

(1) The zero vertical column gives the capacity of open hole.

(2) The zero horizontal line gives the total displacement of drill collar.

l/m x 0.0805 = gal/ft l/m x 0.00192 = bbl/ft

ANNULAR VOLUME BETWEEN DRILL PIPE AND OPEN HOLE (liters per meter)

		Nominal size of drill pipe (in)								
		0 (1)	2 3/8	2 7/8	3 1/2	4	4 1/2	5	5 1/2	6 5/8
0 (2)		(l/m)	3.01	4.44	6.58	8.58	10.84	13.29	16.01	23.05
Diameter of open hole (in)	5 7/8	17.5	14.5	13.0	10.9	8.9				
	6	18.2	15.2	13.8	11.7	9.7				
	6 1/8	19.0	16.0	14.6	12.4	10.4				
	6 1/4	19.8	16.8	15.4	13.2	11.2	9.0			
	6 5/8	22.2	19.2	17.8	15.7	13.7	11.4	8.9		
	6 3/4	23.1	20.1	18.6	16.5	14.5	12.2	9.8		
	7 3/8	27.6	24.5	23.1	21.0	19.0	16.7	14.3	11.5	4.5
	7 7/8	31.4	28.4	27.0	24.8	22.8	20.6	18.1	15.4	8.4
	8 3/8	35.5	32.5	31.1	29.0	27.0	24.7	22.3	19.5	12.5
	8 1/2	36.6	33.6	32.2	30.0	28.0	25.8	23.3	20.6	13.6
	8 5/8	37.7	34.7	33.3	31.1	29.1	26.9	24.4	21.7	14.6
	8 3/4	38.8	35.8	34.4	32.2	30.2	28.0	25.5	22.8	15.7
	9	41.0	38.0	36.6	34.5	32.5	30.2	27.8	25.0	18.0
	9 5/8	46.9	43.9	42.5	40.4	38.4	36.1	33.7	30.9	23.9
	9 7/8	49.4	46.4	45.0	42.8	40.8	38.6	36.1	33.4	26.4
	10 5/8	57.2	54.2	52.8	50.6	48.6	46.4	43.9	41.2	34.2
	12	73.0	70.0	68.5	66.4	64.4	62.1	59.7	57.0	49.9
	12 1/4	76.0	73.0	71.6	69.5	67.5	65.2	62.7	60.0	53.0
	14 3/4	110.2	107.2	105.8	103.7	101.7	99.4	96.9	94.2	87.2
	15	114.0	111.0	109.6	107.4	105.4	103.2	100.7	98.0	91.0
16	129.7	126.7	125.3	123.1	121.1	118.9	116.4	113.7	106.7	
17 1/2	155.2	152.2	150.7	148.6	146.6	144.3	141.9	139.2	132.1	
20	202.7	199.7	198.2	196.1	194.1	191.8	189.4	186.7	179.6	
22	245.2	242.2	240.8	238.7	236.7	234.4	232.0	229.2	222.2	
24	291.9	288.8	287.4	285.3	283.3	281.0	278.6	275.8	268.8	
26	342.5	339.5	338.1	335.9	333.9	331.7	329.2	326.5	319.5	
36	656.7	653.7	652.2	650.1	648.1	645.8	643.4	640.7	633.6	

(1) The zero vertical column gives the capacity of open hole.

(2) The zero horizontal line gives the total displacement of drill pipe with tool joint (average value).

l/m × 0.0805 = gal/ft l/m × 0.00192 = bbl/ft

ANNULAR VOLUME BETWEEN DRILL PIPE AND CASING (liters per meter)

Casing size (in)	Nominal size of drill pipe (in)									
		0 (1)	2 3/8	2 7/8	3 1/2	4	4 1/2	5	5 1/2	6 5/8
	0 (2)	(l/m)	3.01	4.44	6.58	8.58	10.84	13.29	16.01	23.05
4 1/2	9.50	8.48	5.47							
	10.50	8.32	5.31							
	11.60	8.11	5.10							
	13.50	7.79	4.78							
	15.10	7.42	4.41							
	16.90	7.09	4.08							
	17.70	6.92	3.91							
	18.80	6.71	3.70							
5	11.50	10.54	7.53	6.10						
	13.00	10.23	7.22	5.79						
	15.00	9.84	6.83	5.40						
	18.00	9.27	6.83							
	21.40	8.63	6.83							
	23.20	8.29	5.28							
	24.10	8.11	5.10							
5 1/2	14.00	12.73	9.72	8.29						
	15.50	12.42	9.41	7.98						
	17.00	12.13	9.12	7.69						
	20.00	11.57	8.56	7.13						
	23.00	11.05	8.04	6.61						
	26.00	10.48	7.47	6.04						
	26.80	10.26	7.25	5.82						
6 5/8	20.00	18.54	15.53	14.10	11.96					
	23.20	18.03	15.02	13.59	11.45					
	24.00	17.76	14.75	13.32	11.18					
	28.00	16.99	13.98	12.55	10.41					
	32.00	16.32	13.31	11.88	9.74					
	35.00	15.75	12.74	11.31	9.17					
7	17.00	21.66	18.65	17.22	15.08	13.08				
	20.00	21.12	18.11	16.68	14.54	12.54				
	23.00	20.54	17.53	16.10	13.96	11.96				
	26.00	19.96	16.95	15.52	13.38	11.38				
	29.00	19.38	16.37	14.94	12.80	10.80				
	32.00	18.82	15.81	14.38	12.24					
	35.00	18.27	15.26	13.83	11.69					
	38.00	17.76	14.75	13.32	11.18					
	41.00	17.17	14.16	12.73	10.59					
	44.00	16.58	13.57	12.14	10.00					
	46.00	16.23	13.22	11.79	9.65					
7 5/8	24.00	25.01	22.00	20.57	18.43	16.43	14.17			
	26.40	24.61	21.60	20.17	18.03	16.03	13.77			
	29.70	23.95	20.94	19.51	17.37	15.37	13.11			
	33.70	23.19	20.18	18.75	16.61	14.61	12.35			
	35.80	22.71	19.70	18.27	16.13	14.13	11.87			
	39.00	22.24	19.23	17.80	15.66	13.66	11.40			
	42.80	21.42	18.41	16.98	14.84	12.84	10.58			
	45.30	20.98	17.97	16.54	14.40	12.40	10.14			
	47.10	20.59	17.58	16.15	14.01	12.01	9.75			
	8 5/8	24.00	33.22	30.21	28.78	26.64	24.64	22.38	19.93	17.21
28.00		32.57	29.56	28.13	25.99	23.99	21.73	19.28	16.56	
32.00		31.79	28.78	27.35	25.21	23.21	20.95	18.50	15.78	
36.00		31.03	28.02	26.59	24.45	22.45	20.19	17.74	15.02	
40.00		30.24	27.23	25.80	23.66	21.66	19.40	16.95	14.23	
44.00		29.46	26.45	25.02	22.88	20.88	18.62	16.17	13.45	
49.00		28.58	25.57	24.14	22.00	20.00	17.74	15.29	12.57	
52.00		28.01	25.00	23.57	21.43	19.43	17.17	14.72	12.00	

(1) The zero vertical column gives the capacity of the casing.

(2) The zero horizontal line gives the average total displacement of drill pipe with tool joint.

l/m x 0.0805 = gal/ft l/m x 0.00192 = bbl/ft

ANNULAR VOLUME BETWEEN DRILL PIPE AND CASING (liters per meter) (continued)

Casing size (in)	Nominal size of drill pipe (in)									
		0 (1)	2 3/8	2 7/8	3 1/2	4	4 1/2	5	5 1/2	6 5/8
	0 (2)	(l/m)	3.01	4.44	6.58	8.58	10.84	13.29	16.01	23.05
9 5/8	32.30	41.1	38.1	36.6	34.5	32.5	30.2	27.8	25.1	18.0
	36.00	40.3	37.3	35.9	33.8	31.8	29.5	27.0	24.3	17.3
	40.00	39.6	36.5	35.1	33.0	31.0	28.7	26.3	23.5	16.5
	43.50	38.8	35.8	34.4	32.3	30.3	28.0	25.6	22.8	15.8
	47.00	38.2	35.2	33.7	31.6	29.6	27.3	24.9	22.2	15.1
	53.50	36.9	33.9	32.5	30.3	28.3	26.1	23.6	20.9	13.9
	58.40	36.1	33.0	31.6	29.5	27.5	25.2	22.8	20.0	13.0
	59.40	35.8	32.8	31.4	29.2	27.2	25.0	22.5	19.8	12.8
	61.10	35.5	32.5	31.1	29.0	27.0	24.7	22.3	19.5	12.5
	71.80	33.5	30.4	29.0	26.9	24.9	22.6	20.2	17.4	
9 7/8	62.80	45.7	42.7	41.3	39.2	37.2	34.9	32.4	29.7	
10 3/4	32.75	52.6	49.6	48.2	46.1	44.1	41.8	39.3	36.6	29.6
	40.50	51.2	48.2	46.7	44.6	42.6	40.3	37.9	35.2	28.1
	45.50	50.2	47.2	45.7	43.6	41.6	39.3	36.9	34.2	27.1
	51.00	49.2	46.2	44.7	42.6	40.6	38.3	35.9	33.2	26.1
	55.50	48.3	45.3	43.8	41.7	39.7	37.4	35.0	32.3	25.2
	60.70	47.3	44.3	42.9	40.7	38.7	36.5	34.0	31.3	24.2
	65.70	46.3	43.3	41.9	39.7	37.7	35.5	33.0	30.3	23.3
11 3/4	42.00	62.3	59.2	57.8	55.7	53.7	51.4	49.0	46.2	39.2
	47.00	61.3	58.3	56.9	54.7	52.7	50.5	48.0	45.3	38.3
	54.00	60.0	57.0	55.5	53.4	51.4	49.1	46.7	44.0	36.9
	60.00	58.8	55.8	54.4	52.2	50.2	48.0	45.5	42.8	35.8
	65.00	57.8	54.8	53.4	51.2	49.2	47.0	44.5	41.8	34.8
	71.00	56.8	53.8	52.3	50.2	48.2	45.9	43.5	40.8	33.7
13 3/8	48.00	81.9	78.9	77.5	75.3	73.3	71.1	68.6	65.9	58.9
	54.50	80.6	77.6	76.2	74.1	72.1	69.8	67.4	64.6	57.6
	61.00	79.4	76.4	74.9	72.8	70.8	68.5	66.1	63.4	56.3
	68.00	78.1	75.1	73.7	71.5	69.5	67.3	64.8	62.1	55.1
	72.00	77.2	74.2	72.8	70.7	68.7	66.4	64.0	61.2	54.2
	77.00	76.4	73.3	71.9	69.8	67.8	65.5	63.1	60.3	53.3
	80.70	75.6	72.6	71.2	69.0	67.0	64.8	62.3	59.6	52.6
	13 5/8	88.20	74.5	71.5	70.1	67.9	65.9	63.7	61.2	58.5
14	82.50	76.1	73.0	71.6	69.5	67.5	65.2	62.8	60.0	53.0
	94.80	73.7	70.7	69.3	67.2	65.2	62.9	60.5	57.7	50.7
	99.00	73.0	69.9	68.5	66.4	64.4	62.1	59.7	56.9	49.9
	114.00	70.3	67.2	65.8	63.7	61.7	59.4	57.0	54.2	47.2
16	65.00	117.8	114.8	113.4	111.2	109.2	107.0	104.5	101.8	94.8
	75.00	115.9	112.9	111.5	109.3	107.3	105.1	102.6	99.9	92.9
	84.00	114.2	111.2	109.8	107.6	105.6	103.4	100.9	98.2	91.2
	94.50	112.1	109.1	107.7	105.5	103.5	101.3	98.8	96.1	89.1
	109.00	109.3	106.3	104.9	102.7	100.7	98.5	96.0	93.3	86.3
	128.00	105.6	102.6	101.2	99.0	97.0	94.8	92.3	89.6	82.6
18 5/8	87.50	159.7	156.7	155.3	153.1	151.1	148.9	146.4	143.7	136.7
20	94.00	185.3	182.3	180.9	178.7	176.7	174.5	172.0	169.3	162.3
	106.50	182.9	179.9	178.5	176.3	174.3	172.1	169.6	166.9	159.9
	133.00	177.8	174.8	173.4	171.2	169.2	167.0	164.5	161.8	154.8
30	267.00	407.8	404.8	403.4	401.2	399.2	397.0	394.5	391.8	384.8
	310.00	397.0	394.0	392.6	390.4	388.4	386.2	383.7	381.0	374.0

(1) The zero vertical column gives the capacity of the casing.

(2) The zero horizontal line gives the average total displacement of drill pipe with tool joint.

l/m \times 0.0805 = gal/ft l/m \times 0.00192 = bbl/ft

ANNULAR VOLUME BETWEEN CASING AND OPEN HOLE (liters per meter)

		Casing outside diameter (in)																		
		0 (1)	4 1/2	5	5 1/2	6 5/8	7	7 5/8	8 5/8	9 5/8	9 7/8	10 3/4	11 3/4	13 3/8	13 5/8	14	16	18 5/8	20	30
Diameter of open hole (in)	0 (2)	(l/m)																		
5 7/8	17.49	7.2	4.8																	
6	18.24	8.0	5.6																	
6 1/8	19.01	8.7	6.3	3.7																
6 1/4	19.79	9.5	7.1	4.5																
6 5/8	22.24	12.0	9.6	6.9																
6 3/4	23.09	12.8	10.4	7.8																
7 3/8	27.56	17.3	14.9	12.2																
7 7/8	31.42	21.2	18.8	16.1	9.2	6.6														
8 3/8	35.54	25.3	22.9	20.2	13.3	10.7														
8 1/2	36.61	26.3	23.9	21.3	14.4	11.8														
8 5/8	37.69	27.4	25.0	22.4	15.5	12.9	8.2													
8 3/4	38.79	28.5	26.1	23.5	16.6	14.0	9.3													
9	41.04	30.8	28.4	25.7	18.8	16.2	11.6													
9 5/8	46.94	36.7	34.3	31.6	24.7	22.1	17.5													
9 7/8	49.41	39.2	36.7	34.1	27.2	24.6	20.0	11.7												
10 5/8	57.20	46.9	44.5	41.9	35.0	32.4	27.7	19.5												
12	72.96	62.7	60.3	57.6	50.7	48.1	43.5	35.3	26.0			14.4								
12 1/4	76.04	65.8	63.4	60.7	53.8	51.2	46.6	38.3	29.1	26.6	23.6	17.5								
14 3/4	110.2	100.0	97.6	94.9	88.0	85.4	80.8	72.5	63.3	60.8	60.8	51.7	40.3							
15	114.0	103.7	101.3	98.7	91.8	89.2	84.5	76.3	67.1	64.6	64.6	55.5	44.1	23.4						
16	129.7	119.5	117.0	114.4	107.5	104.9	100.3	92.0	82.8	80.3	80.3	71.2	59.8	39.1	35.7					
17 1/2	155.2	144.9	142.5	139.8	132.9	130.3	125.7	117.5	108.2	105.8	105.8	96.6	85.2	64.5	61.1	55.9				
20	202.7	192.4	190.0	187.4	180.4	177.9	173.2	165.0	155.7	153.3	153.3	144.1	132.7	112.0	108.6	103.4				
22	245.2	235.0	232.6	229.9	223.0	220.4	215.8	207.5	198.3	195.8	195.8	186.7	175.3	154.6	151.2	145.9				
24	291.9	281.6	279.2	276.5	269.6	267.0	262.4	254.2	244.9	242.4	242.4	233.3	221.9	201.2	197.8	192.5	162.1	116.1	89.2	
26	342.5	332.3	329.9	327.2	320.3	317.7	313.1	304.8	295.6	293.1	293.1	284.0	272.6	251.9	248.5	243.2	212.8	166.8	139.8	
36	656.7	646.4	644.0	641.4	634.4	631.9	627.2	619.0	609.7	607.3	607.3	598.1	586.7	566.0	562.6	557.4	527.0	480.9	454.0	200.7

(1) The zero vertical column gives the capacity of open hole.

(2) The zero horizontal line gives the total displacement of casing without coupling.

l/m x 0.0805 = gal/ft l/m x 0.00192 = bbl/ft

ANNULAR VOLUME BETWEEN TWO STRINGS OF CASING (liters per meter)

Outer casing (in)	Nominal size of inner casing (in)																			
	0 (1)	4 1/2	5	5 1/2	6 5/8	7	7 5/8	8 5/8	9 5/8	9 7/8	10 3/4	11 3/4	13 3/8	13 5/8	14	16	18 5/8	20		
0 (2)	l/m																			
6 5/8	20.00	18.54	8.28	5.87																
	23.20	18.03	7.77	5.36																
	24.00	17.76	7.50	5.09																
	28.00	16.99	6.73	4.32																
	32.00	16.32	6.06																	
35.00	15.75	5.49																		
7	17.00	21.66	11.40	8.99	6.33															
	20.00	21.12	10.86	8.45	5.79															
	23.00	20.54	10.28	7.87	5.21															
	26.00	19.96	9.70	7.29	4.63															
	29.00	19.38	9.12	6.71	4.05															
	32.00	18.82	8.56	6.15																
	36.00	18.27	8.01	5.60																
	38.00	17.76	7.50	5.09																
	41.00	17.17	6.91	4.50																
	44.00	16.58	6.32	3.91																
46.00	16.23	5.97	3.56																	
7 5/8	24.00	25.01	14.75	12.34	9.68															
	26.40	24.61	14.35	11.94	9.28															
	29.70	23.95	13.69	11.28	8.62															
	33.70	23.19	12.93	10.52	7.86															
	35.80	22.71	12.45	10.04	7.38															
	39.00	22.24	11.98	9.57	6.91															
	42.80	21.42	11.16	8.75	6.09															
45.30	20.98	10.72	8.31	5.65																
47.10	20.59	10.33	7.92	5.26																
8 5/8	24.00	33.23	22.97	20.56	17.90	8.40														
	28.00	32.59	22.33	19.92	17.26	7.76														
	32.00	31.79	21.53	19.12	16.46	6.96														
	36.00	31.04	20.78	18.37	15.71	6.21														
	40.00	30.23	19.97	17.56	14.90															
	44.00	29.47	19.21	16.80	14.14															
49.00	28.59	18.33	15.92	13.26	6.35															

(1) The zero vertical column gives the capacity of casing.
 (2) The zero horizontal line gives the total displacement of casing without coupling.
 l/m x 0.0805 = gal/ft l/m x 0.00192 = bb/ft

ANNULAR VOLUME BETWEEN TWO STRINGS OF CASING (continued) (liters per meter)

Outer casing (in)	Nominal size of inner casing (in)														
	0 (1)	4 1/2	5	5 1/2	6 5/8	7	7 5/8	8 5/8	9 5/8	9 7/8	10 3/4	11 3/4	13 3/8	13 5/8	14
	0 (2)	10.26	12.67	15.33	22.24	24.83	29.46	37.69	46.94	49.41	58.56	69.96	90.64	94.06	99.31
9 5/8	32.30	30.80	28.39	25.73	18.82	16.23	11.60								
	36.00	30.07	27.66	25.00	18.09	15.50	10.87								
	40.00	29.29	26.88	24.22	17.31	14.72	10.09								
	43.50	28.58	26.17	23.51	16.60	14.01	9.38								
	47.00	27.92	25.51	22.85	15.94	13.35	8.72								
	53.50	26.65	24.24	21.58	14.67	12.08									
	58.40	25.79	23.38	20.72	13.81	11.22									
	59.40	25.55	23.14	20.48	13.57	10.98									
	61.10	25.28	22.87	20.21	13.30	10.71									
	71.80	23.19	20.78	18.12	11.21	8.62									
9 7/8	62.80	35.47	33.06	30.40	23.49	20.90									
	32.75	42.37	39.96	37.30	30.39	27.80	23.17	14.94							
10 3/4	40.50	40.92	38.51	35.85	28.94	26.35	21.72	13.49							
	45.50	39.90	37.49	34.83	27.92	25.33	20.70	12.47							
	51.00	38.90	36.49	33.83	26.92	24.33	19.70	11.47							
	55.50	38.01	35.60	32.94	26.03	23.44	18.81								
	60.70	37.03	34.62	31.96	25.05	22.46	17.83								
11 3/4	65.70	36.05	33.64	30.98	24.07	21.48	16.85								
	42.00	51.99	49.58	46.92	40.01	37.42	32.79	24.56	15.31						
	47.00	51.06	48.65	45.99	39.08	36.49	31.86	23.63	14.38						
	54.00	49.72	47.31	44.65	37.74	35.15	30.52	22.29	13.04						
	60.00	48.54	46.13	43.47	36.56	33.97	29.34	21.11							
	65.00	47.56	45.15	42.49	35.58	32.99	28.36	20.13							
13 3/8	71.00	46.52	44.11	41.45	34.54	31.95	27.32	19.09							
	48.00	71.66	69.25	66.59	59.68	57.09	52.46	44.23	34.98	23.36					
	54.50	70.38	67.97	65.31	58.40	55.81	51.18	42.95	33.70	22.08					
	61.00	69.36	66.69	64.03	57.12	54.53	49.90	41.67	32.42	20.80					
	68.00	67.84	65.43	62.77	55.86	53.27	48.64	40.41	31.16	19.54					
	72.00	66.98	64.57	61.91	55.00	52.41	47.78	39.55	30.30	18.68					
	77.00	66.09	63.68	61.02	54.11	51.52	46.89	38.66	29.41	17.79					
80.70	65.34	62.93	60.27	53.36	50.77	46.14	37.91	28.66	17.04						
13 5/8	88.20	64.23	61.82	59.16	52.25	49.66	45.03	36.80	27.55	15.93					

(1) The zero vertical column gives the capacity of casing.
 (2) The zero horizontal line gives the total displacement of casing without coupling.
 l/m x 0.0805 = gal/ft l/m x 0.00192 = bbl/ft

ANNULAR VOLUME BETWEEN TWO STRINGS OF CASING (continued) (liters per meter)

Outer casing (in)	Nominal size of inner casing (in)															
	0 (1)	4 1/2	5	5 1/2	6 5/8	7	7 5/8	8 5/8	9 5/8	9 7/8	10 3/4	11 3/4	13 3/8	13 5/8	14	
	0 (2)	l/m)														
14	82.50 94.80 99.00 114.00	76.05 73.74 72.95 70.25	63.38 61.07 60.28 57.58	60.72 58.41 57.62 54.92	53.81 51.50 50.71 48.01	51.22 48.91 48.12 45.42	46.59 44.28 43.49 40.79	38.36 36.05 35.26 32.56	29.11 26.80 26.01 23.31	17.49 15.18 14.39 11.69						
16	65.00 75.00 84.00 94.50 109.00 128.00	117.80 115.90 114.20 112.10 109.30 105.60	105.13 103.23 101.53 99.43 96.63 92.93	102.47 100.57 98.87 96.77 93.97 90.27	95.56 93.66 91.96 89.86 87.06 83.36	92.97 91.07 89.37 87.27 84.47 80.77	88.34 86.44 84.74 82.64 79.84 76.14	80.11 78.21 76.51 74.41 71.61 67.91	70.86 68.96 67.26 65.16 62.36 58.66	59.24 57.34 55.64 53.54 50.74 47.04	47.84 45.94 44.24 42.14 39.34 35.64	27.16 25.26 23.56 21.46 18.66 14.96				
18 5/8	87.50	159.70	147.03	144.37	137.46	134.87	130.24	122.01	112.76	101.14	89.74	69.06	29.98			
20	94.00 106.50 133.00	185.30 182.90 177.80	172.63 170.23 165.13	169.97 167.57 162.47	163.06 160.66 155.56	160.47 158.07 152.97	155.84 153.44 148.34	147.61 145.21 140.11	138.36 135.96 130.86	126.74 124.34 119.24	115.34 112.94 107.84	94.66 92.26 87.16	55.58 53.18 48.08			
30	267.00 310.00	407.80 397.00	395.13 384.33	392.47 381.67	385.56 374.76	382.97 372.17	378.34 367.54	370.11 359.31	360.86 350.06	349.24 338.44	337.84 327.04	317.16 306.36	278.08 267.28	232.03 221.23	205.12 194.32	

(1) The zero vertical column gives the capacity of casing.

(2) The zero horizontal line gives the total displacement of casing without coupling.

l/m x 0.0805 = gal/ft l/m x 0.00192 = bb/ft

ANNULAR VOLUME BETWEEN CASING AND TUBING (liters per meter)

Outer casing (in)	Nominal size of inner tubing (in)											
		0 (1)	1.050	1.315	1.660	1.900	2.063	2 3/8	2 7/8	3 1/2	4	4 1/2
	0 (2)	(l/m)	0.56	0.88	1.40	1.83	2.16	2.86	4.19	6.21	8.11	10.26
4 1/2	9.50	8.48	7.92	7.60	7.08	6.65	6.32	5.62	4.29			
	10.50	8.32	7.76	7.44	6.92	6.49	6.16	5.46	4.13			
	11.60	8.11	7.55	7.23	6.71	6.28	5.95	5.25	3.92			
	13.50	7.79	7.23	6.91	6.39	5.96	5.63	4.93	3.60			
	15.10	7.42	6.86	6.54	6.02	5.59	5.26	4.56	3.23			
	16.90	7.09	6.53	6.21	5.69	5.26	4.93	4.23				
	17.70	6.92	6.36	6.04	5.52	5.09	4.76	4.06				
	18.80	6.71	6.15	5.83	5.31	4.88	4.55	3.85				
5	11.50	10.54	9.98	9.66	9.14	8.71	8.38	7.68	6.35			
	13.00	10.23	9.67	9.35	8.83	8.40	8.07	7.37	6.04			
	15.00	9.84	9.28	8.96	8.44	8.01	7.68	6.98	5.65			
	18.00	9.27	8.71	8.39	7.87	7.44	7.11	6.41	5.08			
	21.40	8.63	8.07	7.75	7.23	6.80	6.47	5.77	4.44			
	23.20	8.29	7.73	7.41	6.89	6.46	6.13	5.43	4.10			
	24.10	8.11	7.55	7.23	6.71	6.28	5.95	5.25	3.92			
	5 1/2	14.00	12.73	12.17	11.85	11.33	10.90	10.57	9.87	8.54	6.52	
15.50		12.42	11.86	11.54	11.02	10.59	10.26	9.56	8.23	6.21		
17.00		12.13	11.57	11.25	10.73	10.30	9.97	9.27	7.94	5.92		
20.00		11.57	11.01	10.69	10.17	9.74	9.41	8.71	7.38	5.36		
23.00		11.05	10.49	10.17	9.65	9.22	8.89	8.19	6.86	4.84		
26.00		10.48	9.92	9.60	9.08	8.65	8.32	7.62	6.29	4.27		
26.80		10.26	9.70	9.38	8.86	8.43	8.10	7.40	6.07	4.05		
6 5/8		20.00	18.54	17.98	17.66	17.14	16.71	16.38	15.68	14.35	12.33	10.43
	23.20	18.03	17.47	17.15	16.63	16.20	15.87	15.17	13.84	11.82	9.92	7.77
	24.00	17.76	17.20	16.88	16.36	15.93	15.60	14.90	13.57	11.55	9.65	7.50
	28.00	16.99	16.43	16.11	15.59	15.16	14.83	14.13	12.80	10.78	8.88	6.73
	32.00	16.32	15.76	15.44	14.92	14.49	14.16	13.46	12.13	10.11	8.21	6.06
	35.00	15.75	15.19	14.87	14.35	13.92	13.59	12.89	11.56	9.54	7.64	5.49
	7	17.00	21.66	21.10	20.78	20.26	19.83	19.50	18.80	17.47	15.45	13.55
20.00		21.12	20.56	20.24	19.72	19.29	18.96	18.26	16.93	14.91	13.01	10.86
23.00		20.53	19.97	19.65	19.13	18.70	18.37	17.67	16.34	14.32	12.42	10.27
26.00		19.95	19.39	19.07	18.55	18.12	17.79	17.09	15.76	13.74	11.84	9.69
29.00		19.38	18.82	18.50	17.98	17.55	17.22	16.52	15.19	13.17	11.27	9.12
32.00		18.82	18.26	17.94	17.42	16.99	16.66	15.96	14.63	12.61	10.71	8.56
35.00		18.27	17.71	17.39	16.87	16.44	16.11	15.41	14.08	12.06	10.16	8.01
38.00		17.77	17.21	16.89	16.37	15.94	15.61	14.91	13.58	11.56	9.66	7.51
41.00		17.21	16.65	16.33	15.81	15.38	15.05	14.35	13.02	11.00	9.10	6.95
44.00		16.58	16.02	15.70	15.18	14.75	14.42	13.72	12.39	10.37	8.47	6.32
46.00		16.23	15.67	15.35	14.83	14.40	14.07	13.37	12.04	10.02	8.12	5.97

(1) The zero vertical column gives the capacity of the casing.

(2) The zero horizontal line gives the total displacement of tubing without coupling.

l/m × 0.0805 = gal/ft l/m × 0.00192 = bbl/ft

ANNULAR VOLUME BETWEEN CASING AND TUBING (liters per meter) (continued)

Outer casing (in)	Nominal size of inner tubing (in)											
		0 (1)	1.050	1.315	1.660	1.900	2.063	2 3/8	2 7/8	3 1/2	4	4 1/2
	0 (2)	(l/m)	0.56	0.88	1.40	1.83	2.16	2.86	4.19	6.21	8.11	10.26
7 5/8	24.00	25.01	24.45	24.13	23.61	23.18	22.85	22.15	20.82	18.80	16.90	14.75
	26.40	24.61	24.05	23.73	23.21	22.78	22.45	21.75	20.42	18.40	16.50	14.35
	29.70	23.95	23.39	23.07	22.55	22.12	21.79	21.09	19.76	17.74	15.84	13.69
	33.70	23.19	22.63	22.31	21.79	21.36	21.03	20.33	19.00	16.98	15.08	12.93
	35.80	22.71	22.15	21.83	21.31	20.88	20.55	19.85	18.52	16.50	14.60	12.45
	39.00	22.24	21.68	21.36	20.84	20.41	20.08	19.38	18.05	16.03	14.13	11.98
	42.80	21.42	20.86	20.54	20.02	19.59	19.26	18.56	17.23	15.21	13.31	11.16
	45.30	20.98	20.42	20.10	19.58	19.15	18.82	18.12	16.79	14.77	12.87	10.72
	47.10	20.59	20.03	19.71	19.19	18.76	18.43	17.73	16.40	14.38	12.48	10.33
8 5/8	24.00	33.22	32.66	32.34	31.82	31.39	31.06	30.36	29.03	27.01	25.11	22.96
	28.00	32.57	32.01	31.69	31.17	30.74	30.41	29.71	28.38	26.36	24.46	22.31
	32.00	31.79	31.23	30.91	30.39	29.96	29.63	28.93	27.60	25.58	23.68	21.53
	36.00	31.03	30.47	30.15	29.63	29.20	28.87	28.17	26.84	24.82	22.92	20.77
	40.00	30.24	29.68	29.36	28.84	28.41	28.08	27.38	26.05	24.03	22.13	19.98
	44.00	29.46	28.90	28.58	28.06	27.63	27.30	26.60	25.27	23.25	21.35	19.20
	49.00	28.58	28.02	27.70	27.18	26.75	26.42	25.72	24.39	22.37	20.47	18.32
	52.00	28.01	27.45	27.13	26.61	26.18	25.85	25.15	23.82	21.80	19.90	17.75
9 5/8	32.30	41.06	40.50	40.18	39.66	39.23	38.90	38.20	36.87	34.85	32.95	30.80
	36.00	40.33	39.77	39.45	38.93	38.50	38.17	37.47	36.14	34.12	32.22	30.07
	40.00	39.55	38.99	38.67	38.15	37.72	37.39	36.69	35.36	33.34	31.44	29.29
	43.50	38.84	38.28	37.96	37.44	37.01	36.68	35.98	34.65	32.63	30.73	28.58
	47.00	38.19	37.63	37.31	36.79	36.36	36.03	35.33	34.00	31.98	30.08	27.93
	53.50	36.91	36.35	36.03	35.51	35.08	34.75	34.05	32.72	30.70	28.80	26.65
	58.40	36.05	35.49	35.17	34.65	34.22	33.89	33.19	31.86	29.84	27.94	25.79
	59.40	35.81	35.25	34.93	34.41	33.98	33.65	32.95	31.62	29.60	27.70	25.55
	61.10	35.54	34.98	34.66	34.14	33.71	33.38	32.68	31.35	29.33	27.43	25.28
	71.80	33.45	32.89	32.57	32.05	31.62	31.29	30.59	29.26	27.24	25.34	23.19

(1) The zero vertical column gives the capacity of the casing.

(2) The zero horizontal line gives the total displacement of tubing without coupling.

l/m × 0.0805 = gal/ft l/m × 0.00192 = bbl/ft

CAPACITIES OF COILED TUBING

Coiled tubing dimensions					Tube area		Volumes		
Outside diameter (in)	Body weight (lb/ft)	Wall thickness		Inside diameter (in)	Nominal (in ²)	Minimum (in ²)	Capacity (l/m)	Wall displacement (l/m)	External displacement (l/m)
		Nominal (in)	Minimum (in)						
0.750	0.59	0.083	0.078	0.584	0.174	0.165	0.173	0.112	0.285
0.750	0.62	0.087	0.082	0.576	0.181	0.172	0.168	0.117	0.285
1.000	0.79	0.080	0.075	0.840	0.231	0.218	0.358	0.149	0.507
1.000	0.81	0.083	0.078	0.834	0.239	0.226	0.352	0.154	0.507
1.000	0.85	0.087	0.082	0.826	0.250	0.236	0.346	0.161	0.507
1.000	0.92	0.095	0.090	0.810	0.270	0.257	0.332	0.174	0.507
1.000	0.98	0.102	0.097	0.796	0.288	0.275	0.321	0.186	0.507
1.000	1.04	0.109	0.104	0.782	0.305	0.293	0.310	0.197	0.507
1.000	1.17	0.125	0.117	0.750	0.344	0.325	0.285	0.222	0.507
1.250	1.00	0.080	0.075	1.090	0.294	0.277	0.602	0.190	0.792
1.250	1.03	0.083	0.078	1.084	0.304	0.287	0.595	0.196	0.792
1.250	1.08	0.087	0.082	1.076	0.318	0.301	0.587	0.205	0.792
1.250	1.17	0.095	0.090	1.060	0.345	0.328	0.569	0.222	0.792
1.250	1.25	0.102	0.097	1.046	0.368	0.351	0.554	0.237	0.792
1.250	1.33	0.109	0.104	1.032	0.391	0.374	0.540	0.252	0.792
1.250	1.50	0.125	0.117	1.000	0.442	0.416	0.507	0.285	0.792
1.250	1.60	0.134	0.126	0.982	0.470	0.445	0.489	0.303	0.792
1.250	1.82	0.156	0.148	0.938	0.536	0.512	0.446	0.346	0.792
1.250	2.01	0.175	0.167	0.900	0.591	0.568	0.410	0.381	0.792
1.500	1.43	0.095	0.090	1.310	0.419	0.399	0.870	0.271	1.140
1.500	1.52	0.102	0.097	1.296	0.448	0.428	0.851	0.289	1.140
1.500	1.62	0.109	0.104	1.282	0.476	0.456	0.833	0.307	1.140
1.500	1.84	0.125	0.117	1.250	0.540	0.508	0.792	0.348	1.140
1.500	1.95	0.134	0.126	1.232	0.575	0.544	0.769	0.371	1.140
1.500	2.24	0.156	0.148	1.188	0.659	0.629	0.715	0.425	1.140
1.500	2.48	0.175	0.167	1.150	0.728	0.699	0.670	0.470	1.140
1.750	1.48	0.083	0.078	1.584	0.435	0.410	1.271	0.280	1.552
1.750	1.55	0.087	0.082	1.576	0.455	0.430	1.259	0.293	1.552
1.750	1.68	0.095	0.090	1.560	0.494	0.469	1.233	0.319	1.552
1.750	1.80	0.102	0.097	1.546	0.528	0.504	1.211	0.341	1.552
1.750	1.91	0.109	0.104	1.532	0.562	0.538	1.189	0.363	1.552
1.750	2.17	0.125	0.117	1.500	0.638	0.600	1.140	0.412	1.552
1.750	2.31	0.134	0.126	1.482	0.680	0.643	1.113	0.439	1.552
1.750	2.66	0.156	0.148	1.438	0.781	0.745	1.048	0.504	1.552
1.750	2.94	0.175	0.167	1.400	0.866	0.831	0.993	0.559	1.552
1.750	3.14	0.188	0.180	1.374	0.923	0.888	0.957	0.595	1.552
1.750	3.17	0.190	0.182	1.370	0.931	0.897	0.951	0.601	1.552
2.000	2.20	0.109	0.104	1.782	0.648	0.619	1.609	0.418	2.027
2.000	2.50	0.125	0.117	1.750	0.736	0.692	1.552	0.475	2.027
2.000	2.67	0.134	0.126	1.732	0.786	0.742	1.520	0.507	2.027

l/m × 0.0805 = gal/ft l/m × 0.00192 = bbl/ft

CAPACITIES OF COILED TUBING (continued)

Coiled tubing dimensions					Tube area		Volumes		
Outside diameter (in)	Body weight (lb/ft)	Wall thickness		Inside diameter (in)	Nominal (in ²)	Minimum (in ²)	Capacity (l/m)	Wall displacement (l/m)	External displacement (l/m)
		Nominal (in)	Minimum (in)						
2.000	3.07	0.156	0.148	1.688	0.904	0.861	1.444	0.583	2.027
2.000	3.41	0.175	0.167	1.650	1.003	0.962	1.380	0.647	2.027
2.000	3.64	0.188	0.180	1.624	1.070	1.029	1.336	0.690	2.027
2.000	3.67	0.190	0.182	1.620	1.080	1.039	1.330	0.697	2.027
2.000	3.90	0.203	0.195	1.594	1.146	1.106	1.287	0.739	2.027
2.375	2.64	0.109	0.104	2.157	0.776	0.742	2.358	0.501	2.858
2.375	3.00	0.125	0.117	2.125	0.884	0.830	2.288	0.570	2.858
2.375	3.21	0.134	0.126	2.107	0.943	0.890	2.250	0.609	2.858
2.375	3.70	0.156	0.148	2.063	1.088	1.035	2.157	0.702	2.858
2.375	4.11	0.175	0.167	2.025	1.210	1.158	2.078	0.780	2.858
2.375	4.39	0.188	0.180	1.999	1.292	1.241	2.025	0.833	2.858
2.375	4.43	0.190	0.182	1.995	1.304	1.254	2.017	0.841	2.858
2.375	4.71	0.203	0.195	1.969	1.385	1.335	1.964	0.894	2.858
2.375	4.73	0.204	0.196	1.967	1.391	1.342	1.960	0.898	2.858
2.875	3.67	0.125	0.117	2.625	1.080	1.014	3.492	0.697	4.188
2.875	3.92	0.134	0.126	2.607	1.154	1.088	3.444	0.744	4.188
2.875	4.53	0.156	0.148	2.563	1.333	1.268	3.329	0.860	4.188
2.875	5.05	0.175	0.167	2.525	1.484	1.421	3.231	0.958	4.188
2.875	5.40	0.188	0.180	2.499	1.587	1.524	3.164	1.024	4.188
2.875	5.45	0.190	0.182	2.495	1.603	1.540	3.154	1.034	4.188
2.875	5.79	0.203	0.195	2.469	1.704	1.642	3.089	1.099	4.188
2.875	5.82	0.204	0.196	2.467	1.712	1.650	3.084	1.104	4.188
2.875	6.34	0.224	0.216	2.427	1.866	1.804	2.985	1.204	4.188
3.500	4.82	0.134	0.126	3.232	1.417	1.336	5.293	0.914	6.207
3.500	5.57	0.156	0.148	3.188	1.639	1.559	5.150	1.057	6.207
3.500	6.21	0.175	0.167	3.150	1.828	1.749	5.028	1.179	6.207
3.500	6.65	0.188	0.180	3.124	1.956	1.877	4.945	1.262	6.207
3.500	6.72	0.190	0.182	3.120	1.976	1.897	4.932	1.275	6.207
3.500	7.15	0.203	0.195	3.094	2.103	2.025	4.851	1.357	6.207
3.500	7.18	0.204	0.196	3.092	2.112	2.034	4.844	1.363	6.207
3.500	7.84	0.224	0.216	3.052	2.305	2.228	4.720	1.487	6.207
4.500	8.75	0.190	0.182	4.120	2.573	2.469	8.601	1.660	10.261
4.500	9.36	0.204	0.196	4.092	2.753	2.650	8.485	1.776	10.261
4.500	10.23	0.224	0.216	4.052	3.009	2.907	8.319	1.941	10.261
4.500	11.35	0.250	0.242	4.000	3.338	3.237	8.107	2.154	10.261
5.000	11.43	0.224	0.216	4.552	3.361	3.246	10.499	2.168	12.668
5.000	12.68	0.250	0.242	4.500	3.731	3.617	10.261	2.407	12.668

l/m × 0.0805 = gal/ft l/m × 0.00192 = bbl/ft

E

drilling bits and downhole motors

Common sizes and tolerance on new bits (API RP 7G, January 1, 1995).....	E1
IADC roller bit classification system.....	E2
IADC roller bit classification table (IADC/SPE 23937, February, 1992).....	E3
How to use the roller bit table.....	E4
Comparison of roller bits.....	E5-E7
IADC fixed cutter drill bit classification system (IADC/SPE February 18-21, 1992).....	E8-E9
IADC comparison of PDC bits.....	E10-E11
IADC comparison of TPS & natural diamonds bits	E12-E13
IADC dull bit grading (After IADC/SPE 23938-23939 of 1992).....	E14-E16
Parameters for using insert bits and friction bearings (After Baker-Hughes).....	E17
Threads and make-up torques for drill bits and coring bits (API RP 7G, January 1, 1995 - API Spec 7, April 1, 1994).....	E18
Turbodrill.....	E19
Turbodrilling	E20
Performance curves on turbodrill (Specific gravity d , constant flow rate Q_n).....	E21

Turbodrill specifications (Specific gravity of mud 1.20)	E22
Positive displacement motors.....	E23-E24
Performance curves of positive displacement motors for different flow rates Q	E25
Specifications of positive displacement motors (Moineau type)	E26-E29

COMMON SIZES AND TOLERANCE ON NEW BITS (API RP 7G, January 1, 1995)

COMMON SIZES

Sizes other than those shown may be available in limited cutting structure types:

Roller bits

Diameter (in)	
3 3/4	9 1/2
3 7/8	9 7/8
4 1/4	10 3/4
5 7/8	11
6	12 1/4
6 1/8	13 1/2
6 1/4	14 3/4
6 1/2	16
6 3/4	17 1/2
7 7/8	20
8 3/8	22
8 1/2	24
8 3/4	26

Fixed cutter bit

Diameter (in)	
3 7/8	8 1/2
4 1/2	8 3/4
4 3/4	9 1/2
5 7/8	9 7/8
6	10 3/4
6 1/8	12 1/4
6 1/4	14 3/4
6 1/2	16
6 3/4	17 1/2
7 7/8	

TOLERANCE ON NEW BITS

Rock bits

Nominal bit size		Tolerance	
(in)	(mm)	(in)	(mm)
3 3/8 – 13 3/4 incl.	85.7 – 349.3	– 0, + 1/32	– 0, + 0.79
14 – 17 1/2 incl.	355.6 – 444.5	– 0, + 1/16	– 0, + 1.59
17 5/8 and larger	447.7 and larger	– 0, 3/32	– 0, + 2.38

Diamond and PDC bits

Nominal bit size		Tolerance	
(in)	(mm)	(in)	(mm)
up to 6 1/4	up to 158.8	+ 0, – 0.015	+ 0, – 0.38
6 25/32 – 9	172.2 – 228.6	+ 0, – 0.020	+ 0, – 0.51
9 1/32 – 13 3/4	229.4 – 349.3	+ 0, – 0.030	+ 0, – 0.76
13 25/32 and larger	350.0 and larger	+ 0, – 0.045	+ 0, – 1.14

IADC ROLLER BIT CLASSIFICATION SYSTEM

The 1992 version of the IADC classification (SPE/IADC 1992 No. 123937) contains minor changes from the 1987 Roller Bit Classification System.

In 1987, the Classification System was changed to include a fourth character to denote features available. The 1992 revision added some letters to the classification (B, H, L, M, T and W) and deleted the R letter.

First digit: Cutting Structure Series (1 – 8)

Eight categories or "Series" numbers describe general formation characteristics.

Series 1, 2 and 3 refer to steel tooth (milled tooth) bits.

Series 4, 5, 6, 7 and 8 refer to insert (tungsten carbide) bits.

Within the steel tooth and insert groups, the formation becomes harder and more abrasive as the Series numbers increase.

Second digit: Cutting Structure Types (1 – 4)

Each Series is divided into 4 "Types" or degrees of hardness. Type 1 refers to bits designed for the softest formation in a particular Series. Type 4 refers to the hardest formation within the Series.

Third digit: Bearing/Gage (1 – 7)

Seven categories of bearing design and gage protection are defined as "Bearing/Gage":

1 = standard roller bearing

2 = roller bearing, air-cooled

3 = roller bearing, gage-protected

4 = sealed roller bearing

5 = sealed roller bearing, gage-protected

6 = sealed friction bearing

7 = sealed friction bearing, gage-protected.

Categories 8 and 9 are reserved for future use.

Additional letter

A = air application

B = special bearing seal

C = center jet

D = deviation control

E = extended jets

G = gauge/body protection

H = horizontal/steering application

J = jet deflection

L = lug pads

M = motor application

S = standard steel tooth model

T = two cone bits

W = enhanced cutting structure

X = predominantly chisel tooth insert

Y = conical tooth insert

Z = other shape insert

IADC ROLLER BIT CLASSIFICATION TABLE (IADC/SPE 23937, February, 1992)

Formations	Series	Types	Standard roller bearing	Roller bearing air-cooled	Roller bearing gage protected	Sealed roller bearing	Sealed roller bearing gage protected	Sealed friction bearing	Sealed friction bearing gage protected	Features Available	
											1
Steel tooth bits	1 Soft formations with low compressive strength and high drillability	1								A	
		2								B	
		3									C
		4									D
	2 Medium to medium hard formations with high compressive strength	1									E
		2									G
		3									H
		4									J
	3 Hard semi-abrasive and abrasive formations	1									L
		2									M
		3									S
		4									T
4 Soft formations with low compressive strength and high drillability	1									W	
	2									X	
	3									Y	
	4									Z	
5 Soft to medium soft formations with low compressive strength	1										
	2										
	3										
	4										
6 Medium hard formations with high compressive strength	1										
	2										
	3										
	4										
7 Hard semi-abrasive and abrasive formations	1										
	2										
	3										
	4										
8 Extremely hard and abrasive formations	1										
	2										
	3										
	4										

HOW TO USE THE ROLLER BIT TABLE

EXAMPLE OF THE CHOICE OF A BIT

The formation to be drilled is soft, with low compressive strength and high drillability. We wish to use a milled tooth bit with sealed friction bearings.

The table on page E 3 gives us the bit code No.:

- (a) First digit: soft formation with high drillability: **1**
- (b) Second digit: estimated hardness in series 1 above: **2**
- (c) Third digit: sealed bearings: **6**.

Bit code No. 126

The table on page E 5 gives a choice between:

- (a) Hughes: ATJ2, J2, J2T
- (b) Reed: EHP12, HP12
- (c) Security: S33F
- (d) Smith: FDT
- (e) Varel: L126

HOW TO KNOW THE DESIGN OF A ROCK BIT

Let us consider Reed HP52 bit. Which formation is it designed for?

Table E 7 states that it is equivalent to the Hughes ATJ22C, ATM22C, ATJ28, ATM28, Security S85F, S85CF, Smith F27, MF27 and Varel ETD527, V527 bits, and its code No. is **527**.

Table E 3 shows us that it is an **insert bit** for **soft to medium soft formations** with **hardness 2** and that it has **sealed bearings and gage protectors**.

Note

Bit classifications are general guidelines only. All bit types will drill effectively in formations other than those specified. It is the manufacturer's responsibility to classify his bits in these tables.

COMPARISON OF ROLLER BITS

Milled tooth bits

Code	Hughes Christ.	Reed	Security DBS	Smith	Varel
111	R1	Y11	S3SJ 2S3JD	DSJ	L111
114	ATX1, GTX1 X3A		S33S, MS33S SS33S	SDS	L114
115	GTXG1, MAXG1 MAXGT1	EMS11G S11G	SS33SG ERA 1RD	MSDSH MSDSSH	ETR1G
116	ATJ1, ATJS ATM1/H/S, GT1	HP11 HP11+	S33SF, PSF S33SFX	FDS, FDS+ FDSS+	L116
117	ATJG1H, GT1H ATMG1/S, GTG1 ATMGT1	MHP11G MHP11DH	S33SGF ERA MPSF	MFDSH MSDSHOD	L117 L117GT ETD1G
121	R2	Y12	S3J, S3TJ	DTJ	L3S, L121
126	ATJ2, J2, J2T	EHP12, HP12	S33F	FDT	L126
131	R3	Y13	S4J, S4TJ, S4T	DGJ	L3, L131
135	GTXG3, MAXG3 MAXGT3, XGG	EMS13G ETS13G	S44G SS44G	MSDGH SDGH	L135 ETR3G
136		HP13		FDG	L136
137	JG3, ATMG3 ATMGT3	HP13G MHP13G/DH	S44GF S44F	FDGH MFDGH	L137
215		MS21G, S21G	M44NG MM44NG	SVH	
217	JG4	HP21G	M44NGF	FVH	
317	JG7	HP31G			

COMPARISON OF ROLLER BITS

(continued)

Insert tooth bits

Code	Hughes Christ.	Reed	Security DBS	Smith	Varel
415	AT05, GTX03 MAX00/03/05	MS41H-M MS41HD-M	SS80	M02S	ETD415
417	ATJ00/05 ATM00/05 ATMGT00/03 GT00, GT03	EHP41H	S80F ERA03 ERA03D	F05	ETD417
425	ATX05C, MAX05C		SS81	M05S	
427	ATJ05C, ATM05C GT03C, GT05C		S81F	F07	
435	ATX11H/S ATX11, GTX09 MAX11H/GT09	MS43A, MS43A-M MS43ADM, S43A MS43HM/HDM	S82 SS82	M1S	ETD435
437	ATJ11/H/S ATM11/H/HG ATMGT09, GT09	EHP43/A/H EHP43AD/AH HP43/A/AM/M	S82F S82CF SS82F	F1, F1S	ETD437 V437
445	GTX18, ATX11C MAX09C/GT18	MS44A MS44AD		15JS, M15S	ETD445
447	ATJ11C, ATJ18 ATM11C/11CG ATM18/GT18 GT09C/18/18C	HP44M	S83F SS83F	F15 F15S MF15	ETD437C

COMPARISON OF ROLLER BITS

(continued)

Insert tooth bits

Code	Hughes Christ.	Reed	Security DBS	Smith	Varel
515	ATX22 MAX22/G	MS51A/AM MS51ADM, S51A	S84, SS84	2JS, M2S	ETD515
517	ATJ22/G/S, GT20 ATM22/G, GT09C	EHP51/A/H/X/AD HP51/A/AM/H/HM	S84F, S84CF DS84F, SS84F	A1, F15H, F17, F2 F2H, F25/A, MF2H	ETD517/C V517
525				M27S	ETD525
527	ATJ22C, ATM22C ATJ28, ATM28 GT20C, GT28	HP52/A/X/M	S85F, S85CF	F27, MF27, F27i	ETD527/C V527 EDT527CB/CH
535	ATX33	MS53, MS53D	S86, SS86	3JS, M3S	ETD535
537	ATJ33/S/A ATM33, ATJ35/G	EHP53/A/D/AD HP53/A/AM/D/AD			ETD537 V537
545			S88		ETD545
547	ATJ33C, ATJ35C ATJ35CG ATM33C	HP54	S88F, S88CF S88FA	F35, F37 F37D, F37A	V537C EDT537C/CH ETD547A
615	ATX44		M84	4JS	ETD615, V615
617	ATJ44/A/CA ATJ44D, ATJ44G	EHP61/A/D/AD HP61/A/AD	M84, M84CF M84FA, M85F	F4, F4H F45A, F45H	ETD617 V617/A
625	ATX44C	MS62/D, S62A	M88, MM88, M89T	5GA, 5JA	ETD625, V625
627	ATJ44C	EHP62/A HP62/A/JAK/D/AD	M85F, M88F M88FA, M89TF	F47, F47H, F5	ETD627 V627
637	ATJ55/A/D/R	EHP63, HP63/D	M89F	F57, F57A	ETD637, V637
647	ATJ66		F67	M90F	
737	ATJ77, ATM77	EHP73, HP73/D	H87F	F7	V737
747	ATJ88		H88F	F8	
837	ATJ99/A, ATM99	EHP83/D, HP83/D	H100F	F9	

IADC FIXED CUTTER DRILL BIT CLASSIFICATION SYSTEM (IADC/SPE February 18-21, 1992)

Fixed-Cutter Drill Bit Classification System (SPE/IADC 1987 No. 16142), which attempted to describe each bit style individually was not being used.

The new classification system is composed of four characters, designating body material, cutter density, cutter size or type, and profile, respectively. It is presented as an attempt to improve the ability to classify and thus employ fixed-cutter PDC and diamond drill bits more effectively.

The proposed system is notably simpler than the former system. It no longer considers hydraulics.

The benefit of the new fixed-cutter classification system is that it allows classification and grouping of similar bits.

First character

The first character becomes **M** for **matrix** or **S** for **steel** body construction respectively.

Second character

The second character is labeled **density**, and ranges from 1 to 4 for PDC bits, and from 6 to 8 for surface-set bits using diamond-type cutters. Numerals 0, 5 and 9 are reserved for future use.

Third character

The third character (digits 1 to 4) represents:

- (a) The size of PDC cutter on this type of bit, or
- (b) The diamond type for surface-set bits.

Fourth character

The fourth character (digits 1 to 4) gives an idea of basic **appearance** of the bit, based on overall length of the cutting face of the bit.

Examples

• Code S423

This is a (**S**) Steel body PDC bit with a cutters density (**4**) of 50 cutters or more and a size (**2**) (14 to 24 mm) for the cutters. The profile (**3**) is a medium profile.

In the tables E 10-E 11, several bits correspond to the code S423 or M423:

Christensen G547, R547, G549, R549

Diamant Boart Stratabit FM2563, FM2565, FM2865

Hycalog DS68, DS78H, DS77H, DS70H

Crystal Profor RD51

Geodiamond M44, M61, M68, M61V.

• Code M713

This is a (**M**) Matrix body Surface-Set bit using diamond-type cutter with a density/size (**7**) of 3 to 7 stones per carat of (**1**) natural diamonds. The profile (**3**) is medium longer.

In the tables E 12-E 13, several bits correspond to the code M713:

Christensen D262, D331

Diamant Boart Stratabit TB16

Hycalog 730, 733, 744, 753, 901

Crystal Profor H300

Geodiamond D54, D73.

IADC FIXED CUTTER DRILL BIT CLASSIFICATION SYSTEM (IADC/SPE February 18-21, 1992) (continued)

First character: body material

- M = matrix body construction
- S = steel body construction

Second character: density

PDC bits

- 1 = 30 or fewer 1/2 in cutters
- 2 = 30 to 40 1/2 in cutters
- 3 = 40 to 50 1/2 in cutters
- 4 = 50 or more 1/2 in cutters

Surface-set cutters bits

- 6 = diamond sizes larger than 3 SPC*
- 7 = from 3 SPC to 7 SPC*
- 8 = diamond size smaller than 7 SPC*

Third character: size or type

PDC size

- 1 = cutters larger than 24 mm
- 2 = cutters from 14 mm to 24 mm
- 3 = cutters of 13.3 mm (1/2 in)
- 4 = cutters of 8 mm

Surface-set cutters bits type

- 1 = natural diamonds
- 2 = TSP material
- 3 = combination cutter type
- 4 = impregnated diamond

Fourth character: body style

- 1 = fishtail PDC bit or flat TSP and natural diamond bit
- 2 = short bit profile
- 3 = medium bit profile
- 4 = long bit profile

for example, a long-flanked "turbine style" bit would be clearly categorized as a 4.

* SPC means Stones per Carat (1 carat = 0.2 grams).

IADC COMPARISON OF PDC BITS

Cutters density	Size		Body style										
			1 Fishtail					2 Short					
			HC	DBS	HYC	CRYST	GEO	HC	DBS	HYC	CRYST	GEO	
1	1	> 24		B9-44									
	2	14-24	R523 G573 G554 AG574	B9-33 FM2466	DS40H	S45	S94 M94 M96 M97	G536	FM2862				
	3	< 14	R443 R423	FM2445 FM2446 FM2648						DS100H DS43ST			
2	1	> 24		B9-44									
	2	14-24	G/R526 G526 AR526 AG526	B9-33	DS61H	S65 I			TD19L	DS105H	S66		
	3	< 14	R426 AR426	FM2445 TD13L	DS53H DS39H			R482	HZ23-2	DS95H DS35 DS35H DS44ST		M53 M53V	
3	1	> 24											
	2	14-24		FM2465 FM2665					FM2862	DS68H DS88H DS81			
	3	< 14		FM2643 FM2445				G/R435 AG435 AR435 R335		DS107H DS102H DS48H	RD3		
4	1	> 24											
	2	14-24		FM2365 FM2463 FM2365	DS103H		M83 M83V		FM2563 FM2565 FM2865		S75		
	3	< 14							FM2643 FM2745 FM2545 FM2845	DS90H DS56H DS85H DS84H	RD1001 RD1002	M22 M27 M22V M27V	

HC = Hughes Christensen; DBS = Security Diamant Boart Stratatabit; HYC = Hycalog; CRYST = Crystal Profor;
GEO = Geodiamond.

IADC COMPARISON OF PDC BITS (continued)

Cutters density	Size		Body style										
			3 Medium					4 Long					
			HC	DBS	HYC	CRYST	GEO	HC	DBS	HYC	CRYST	GEO	
1	1	> 24											
	2	14-24					S81 S91 M80 S76		FM2566				
	3	< 14			DS38								
2	1	> 24											
	2	14-24		B25 FM2565	DS80H DS76H DS34H DS76H	S250	M91 M75 M88 S82						
	3	< 14		FM2743 FM2943	DS46H		M75V						
3	1	> 24											
	2	14-24	G/R535 AG545		DS104 DS90 DS86 DS70	RD50	M71 M71V		FM2862	DS68H			
	3	< 14		FM2943 FM2643 FM2943			M42 M50	R445 AG445 AR445		DS92			
4	1	> 24											
	2	14-24	G/R547 G/R549 AR547	FM2563 FM2565 FM2865	DS68 DS78H DS77H DS70H	RD51	M44 M61 M68 M61V		FM2665 FM2865		S265H		
	3	< 14	G/R437 AG437 AR437 G/R447	FM2643 FM2745 FM2546 FM2845	DS93H DS75H DS47H DS47H	RD90H	M34/M35 M36/M37 M39/M40 M41/M42	G417	B10-25 B36-2 FM2745 FM2846	DS65H DS92H DS92H DS57H	S280H S280HY		

HC = Hughes Christensen; DBS = Security Diamant Boart Stratabit; HYC = Hycalog; CRYST = Crystal Profcor; GEO = Geodiamond.

E 12

IADC COMPARISON OF TPS & NATURAL DIAMONDS BITS

Cutters size	Body style												
	Element		1 Flat					2 Short					
			HC	DBS	HYC	CRYST	GEO	HC	DBS	HYC	CRYST	GEO	
6 < 3 SPC*	1	NAT*											
	2	TSP*				DK320			TT521				
	3	COMB*				DK320RC							
7 3-7 SPC*	1	NAT*	D411ST(M) D42SM(M)			K300 DK300			D41 D24			H400	D42
	2	TSP*	S296ST(M)		828ST						263 263ND		
	3	COMB*											
8 > 7 SPC*	1	NAT*		TB26							585		
	2	TSP*											
	3	COMB*		TBT26									
	4	IMP*	S279(M)		480			K33 K35				460, 461 462, 463 464, 470 471/72/73	

HC = Hughes Christensen; DBS = Security Diamant Boart Stratabit; HYC = Hycalog; CRYST = Crystal Profor; GEO = Geodiamond.

* NAT = Natural Diamond Bits; TSP = Thermostable; COMB = Combination Cutter Bits; IMP = Impregnated Diamond Bits; SPC = Stones Per Carat.

IADC COMPARISON OF TPS & NATURAL DIAMONDS BITS (continued)

Cutters size	Body style											
	Element		3 Medium					4 Long				
			HC	DBS	HYC	CRYST	GEO	HC	DBS	HYC	CRYST	GEO
6 < 3 SPC*	1	NAT*				H200	D62 D62HT D71 D72	T18				D51 D52
	2	TSP*			211 241			S725	TT561			
	3	COMB*	S225 Z437					SD248	TBT17		M320 M320RC	
7 3-7 SPC*	1	NAT*	D262 D311	TB16	753 901 744 730, 733	H300	D54 D73	T51 D331(M)				D53
	2	TSP*	226		223 243 223ND 243ND			S248	TT593			
	3	COMB*							TBT703			
8 > 7 SPC*	1	NAT*									H600	
	2	TSP*										
	3	COMB*										
	4	IMP*		TBT601MP	445 442 443 450							

HC = Hughes Christensen; DBS = Security Diamant Boart Stratabit; HYC = Hycalog; CRYST = Crystal Profor;
GEO = Geodiamond.

* NAT = Natural Diamond Bits; TSP = Thermostable; COMB = Combination Cutter Bits; IMP = Impregnated Diamond Bits; SPC = Stones Per Carat.

IADC DULL BIT GRADING (After IADC/SPE 23938-23939 of 1992)

The dull grading system applies both to roller bits and fixed cutter bits. The system is flexible enough for use in bit reports, daily reports and databases.

Cutting structure				Bearing seals	Gage	Other dull char.	Reason pulled
Inner	Outer	Dull char.	Location				
Table 1	Table 1	Table 3	Table 4	Table 5	Table 6	Table 3	Table 8

Table 1

Inner cutting structure (inner = inner 2/3 of the bit)

Outer cutting structure (outer = outer 1/3 of the bit – gage row only)

In columns 1 and 2 a linear scale from **0** to **8** is used to describe the condition of the cutting structure according to the following:

Steel tooth bits

A measure of lost tooth height due to abrasion and/or damage:

0 = No loss of tooth height

1

⋮

8 = Total loss of tooth height

Insert bits

A measure of total cutting structure reduction due to lost, worn and/or broken inserts:

0 = No lost, worn and/or broken inserts

1

⋮

8 = All inserts lost, worn and/or broken

Fixed cutter bits

A measure of lost, worn and/or broken cutting structure:

0 = No lost, worn and/or broken cutting structure

1

⋮

8 = All of cutting structure lost, worn and/or broken.

IADC DULL BIT GRADING (After IADC/SPE 23938-23939 of 1992) (continued)

Table 2 – Dull characteristics
(Use only cutting structure related codes)

BC* = Broken Cone	LN = Lost Nozzle
BF = Bond Failure	LT = Lost Teeth/Cutters
BT = Broken Teeth/Cutters	OC = Off Center Wear
BU = Balled Up Bit	PB = Pinched Bit
CC* = Cracked Cone	PN = Plugged Nozzle/Flow Passage
CD* = Cone Dragged	RG = Rounded Gage
CI = Cone Interference	RO = Ring Out
CR = Cored	SD = Shirttail Damage
CT = Chipped Teeth/Cutters	SS = Self Sharpening Wear
ER = Erosion	TR = Tracking
FC = Flat Crested Wear	WO = Washed Out Bit
HC = Heat Checking	WT = Worn Teeth/Cutters
JD = Junk Damage	NO = No Dull Characteristics
LC* = Lost Cone	

* Show cone # or #'s under location (table 3).

Table 3 – Location

Roller cone		Fixed cutter
N = nose row	Cone #	C = cone
M = middle row	1	N = nose
G = gage row	2	T = taper
A = all rows	3	S = shoulder
		G = gage
		A = all rows

Table 4 – Bearings/seals

Non-sealed bearings	Sealed bearings
A linear scale estimating bearing life used: 0 = no life used 8 = all life used	E = seals effective F = seals failed N = not able to grade X = fixed cutter bit

Table 5 – Gage

Measure in fraction of an inch:	
I	in gage
0 – 1/16 in	out of gage
2/16 – 1/8 in	out of gage
.....	

IADC DULL BIT GRADING (After IADC/SPE 23938-23939 of 1992) (continued)

Table 6 – Reason pulled or run terminated

<p>BHA = Change Bottom Hole Assembly DMF = Downhole Motor Failure DTF = Downhole Tool Failure DSF = Drill String Failure DST = Drill Stem Test DP = Drill Plug CM = Condition Mud CP = Core Point FM = Formation Change HP = Hole Problems</p>	<p>LIH = Left In Hole HR = Hours On Bit LOG = Run Logs PP = Pump Pressure PR = Penetration Rate RIG = Rig Repair TD = Total Depth/Casing Depth TW = Twist Off TQ = Torque TR = Weather Conditions</p>
---	--

Location designation

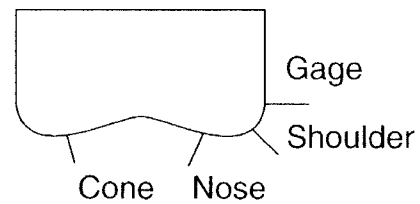
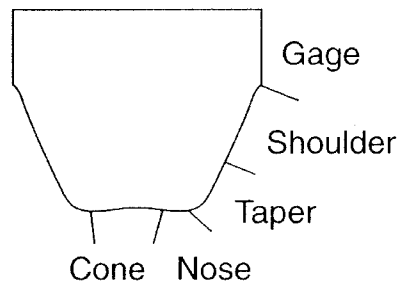
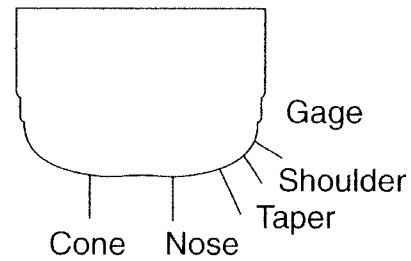
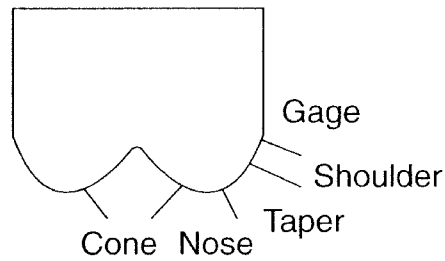

PARAMETERS FOR USING INSERT BITS AND FRICTION BEARINGS (After Baker-Hughes)

For ATJ and ATM series, the numbers in the table indicate the product of bit weight (W) in 1000 daN times rotary speed (N) in revolution per minute that the bearing can safely handle.

Note: This table only considers bearing capability and does not consider compact breakage or seal failure, which may be the limiting factors for bit performance.

WN	4 3/4	5 7/8	6	6 1/8	6 1/2	7 7/8	8 3/8	8 1/2	8 3/4	9 1/2	9 7/8	10 5/8	12 1/4	14 3/4	17 1/2
ATJ05											1975		2850		
ATJ11								1625		2125	1975		2850		
ATM11						1450		1450	1725		1975		2550		3325
ATJ1								1650					2850		
ATJ22		1225	1225	1225	1225		1725	1925		2225	2225	2175	2900		
ATM22						1525		1625	1775	2225	2075		2625	2425	3550
ATJ2C								1925		2225	2225		2900		
ATJ33	1150	1225	1225	1225	1225		1725	1925		2225	2225	2175	2900		
ATM33						1525	1525	1625	1625		2075		2625		3950
ATJ33C								1925		2225	2225	2175	2900		
ATJ44			1175		1300		1675	2050		2150	2150	2125	2775		
ATJ44C								2050		2150	2150	2125	2775		
ATJ55	1100	1175	1175	1175			1675	2050		2150	2150		2775		
ATJ55R					1300		1675	2050		2150	2150		2775		
ATJ77					1300			2050		2150	2150		2775		
ATJ99					1300			2050		2150	2125				

For WN in 1000 lb \times rpm, multiply the number given in the table by 2.25.

Example: 8 1/2 in bit – ATM22: $WN = 1625$ (1000 daN \times rpm)

$$WN = 1625 \times 2.25 = 3650 \text{ (1000 lb } \times \text{ rpm)}$$

The following alternatives are available:

(a) WOB 16 250 daN (36 500 lb)

(b) rotary speed 100 rpm (100 rpm)

or:

(a) WOB 20 000 daN (45 000 lb)

(b) rotary speed 81 rpm (81 rpm)

or any other combination, according to whether the rotary speed or weight on bit is adjusted for best action on the formation.

$$\text{daN} \times 2.25 = \text{lb}$$

THREADS AND MAKE-UP TORQUES FOR DRILL BITS AND CORING BITS

(API RP 7G, January 1, 1995 – API Spec 7, April 1, 1994)

Rock bits

Bit size (in)	Bit thread	Bit thread	Make-up torque	
			(daN.m)	(ft.lb)
3 3/4 – 4 1/2	2 3/8 REG	2 3/8 REG	400 – 480	3 000 – 3 500
4 5/8 – 5	2 7/8 REG	2 7/8 REG	600 – 750	4 500 – 5 500
5 1/8 – 7 3/8	3 1/2 REG	3 1/2 REG	950 – 1 200	7 000 – 9 000
7 1/2 – 9 3/8	4 1/2 REG	4 1/2 REG	1 600 – 2 200	12 000 – 16 000
9 1/2 – 14 3/8	6 5/8 REG	6 5/8 REG	3 800 – 4 300	28 000 – 32 000
14 1/2 – 18 1/2	6 5/8 or 7 5/8 REG	7 5/8 REG	4 600 – 5 400	34 000 – 40 000
18 5/8 to 26	7 5/8 or 8 5/8 REG	8 5/8 REG	5 400 – 8 100	40 000 – 60 000
27 and larger	8 5/8 REG			

Diamond and PDC bits

Bit size (in)	Bit thread identification	Maximum pin ID (in)	Bit sub OD (in)	Minimum make-up torque (1)	
				(daN.m)	(ft.lb)
3 11/16 – 4 1/2	2 3/8 REG	1	3	243	1 791
			3 1/8	328	2 419
			3 1/4	418	3 085
4 17/32 – 5	2 7/8 REG	1 1/4	3 1/2	417	3 078
			3 3/4	626	4 617
			3 7/8	632	4 658
5 1/32 – 7 3/8	3 1/2 REG	1 1/2	4 1/8	701	5 171
			4 1/4	855	6 306
			4 1/2	1 039	7 660
7 13/32 – 9 3/8	4 1/2 REG	2 1/4	5 1/2	1 688	12 451
			5 3/4	2 234	16 476
			6	2 380	17 551
			6 1/4	2 408	17 757
9 13/32 – 14 1/2	6 5/8 REG	3 1/4	7 1/2	5 030	37 100
			7 3/4	5 133	37 857
			8	5 178	38 193
			8 1/4	5 224	38 527
14 9/16 – 18 1/2	7 5/8 REG	3 3/4	8 1/2	6 548	48 296
			8 3/4	7 824	57 704
			9	8 130	59 966
			9 1/4	8 200	60 480
			9 1/2	8 256	60 895

(1) Normal torque range is tabulated value plus 10%.

Coring bits

Core barrel size (in)	Make-up torque	
	(daN.m)	(ft.lb)
4 1/8	400 – 490	3 000 – 3 600
4 1/2	680 – 800	5 000 – 6 000
4 3/4	550 – 660	4 050 – 4 850
5 3/4	1 000 – 1 190	7 400 – 8 800
6 1/4 × 3	2 020 – 2 410	14 900 – 17 800
6 1/4 × 4	1 100 – 1 330	8 150 – 9 800
6 3/4	1 340 – 1 630	9 900 – 12 000
8	2 580 – 3 080	19 000 – 22 700

TURBODRILL

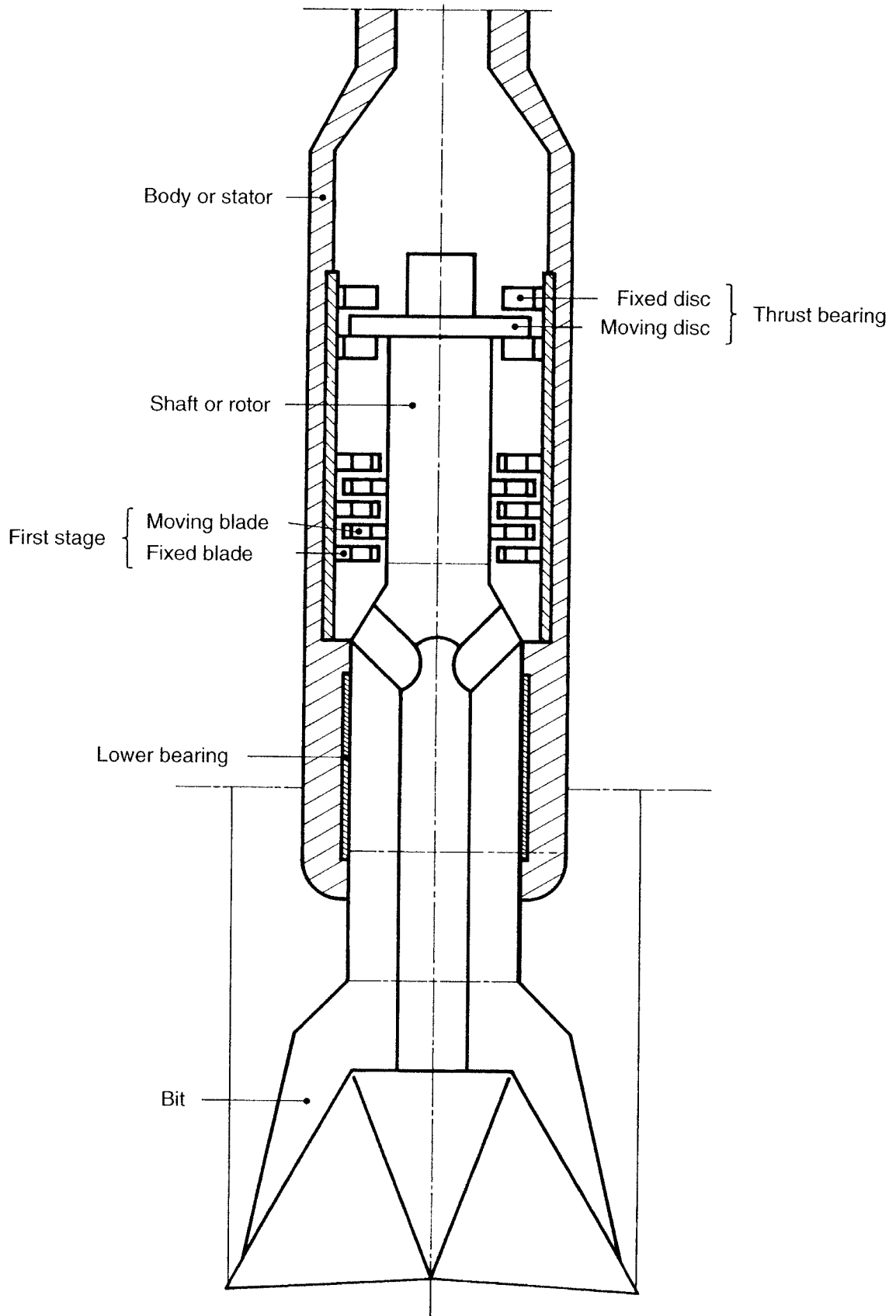

TURBODRILLING

I TURBODRILL SPECIFICATIONS

Turbodrills are characterized by:

- (a) Outside diameter of the body
- (b) Number of stages
- (c) Number of sections
- (d) Type of blades
- (e) Length and weight.

The hydraulic specifications are given for a nominal pump flow Q_n and a mud specific gravity of 1.20.

These nominal specifications are:

- (a) Nominal speed N_n
- (b) Nominal horsepower output P_n
- (c) Nominal torque T_n
- (d) Nominal pressure drop Δp_n
- (e) Axial thrust P_a .

The nominal horsepower output is the maximum output obtained with nominal pump flow.

The efficiency of the turbodrill is equal to the ratio of the mechanical horsepower supplied by the turbodrill to the hydraulic horsepower supplied to the turbodrill:

$$\eta = \frac{\text{Mechanical horsepower}}{\text{Hydraulic horsepower}}$$

II VARIATIONS IN NOMINAL SPECIFICATIONS WITH PUMP FLOW AND MUD SPECIFIC GRAVITY

If N_n , P_n , T_n and Δp_n are the nominal specifications of a turbodrill for a flow rate Q_n and specific gravity of 1.20, for a flow rate Q and specific gravity d , the specifications are:

$$N'_n = N_n \frac{Q}{Q_n}$$

$$T'_n = T_n \frac{d}{1.20} \left[\frac{Q}{Q_n} \right]^2$$

$$P'_n = P_n \frac{d}{1.20} \left[\frac{Q}{Q_n} \right]^3$$

$$\Delta p'_n = \Delta p_n \frac{d}{1.20} \left[\frac{Q}{Q_n} \right]^2$$

The axial thrust is approximately proportional to the specific gravity d and to the square of Q .

PERFORMANCE CURVES OF TURBODRILL (Specific gravity d , constant flow rate Q_n)

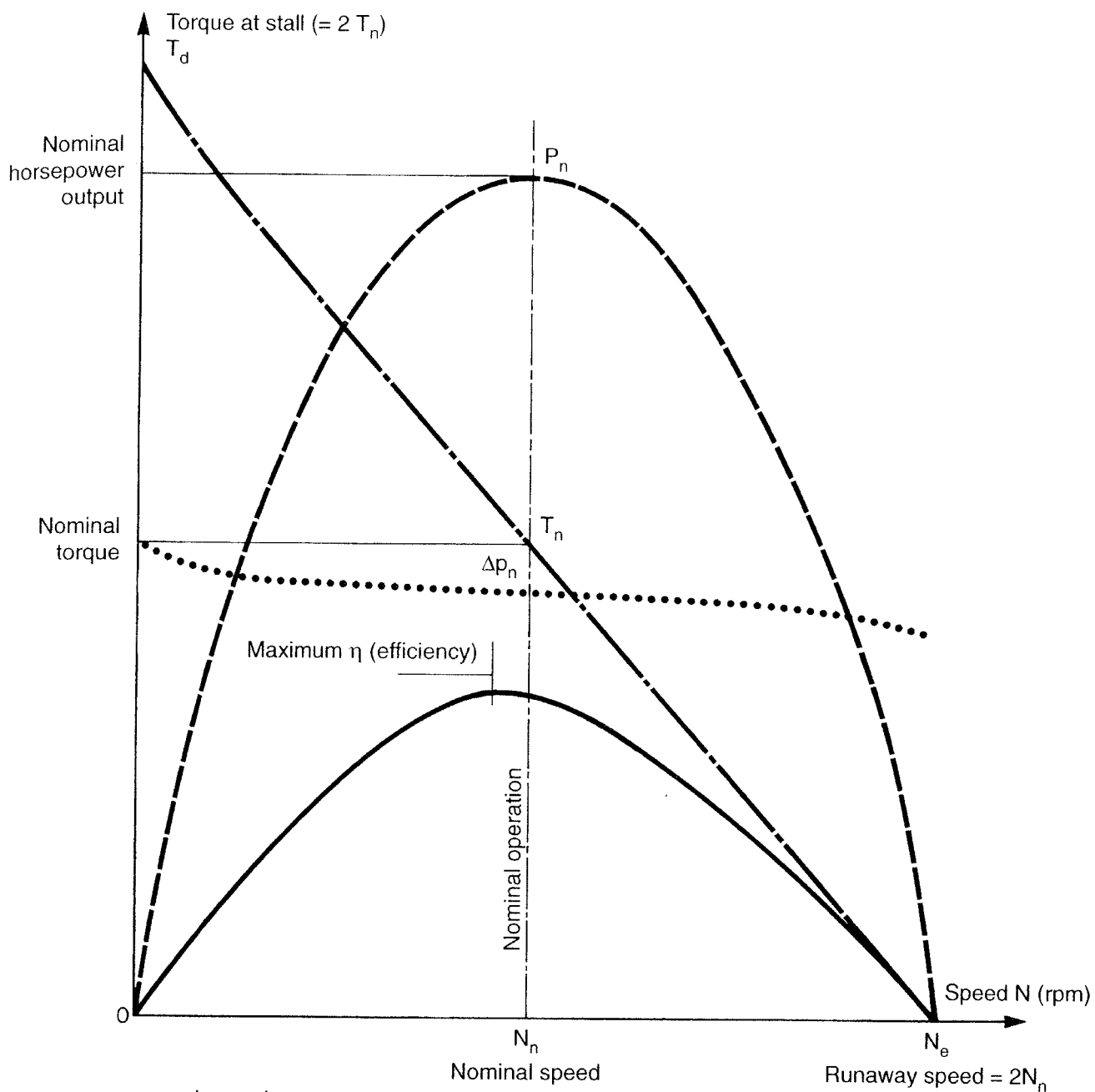

Legend:

- P horsepower
- Δp pressure drop, hydraulic thrust
- η efficiency
- T torque

TURBODRILL SPECIFICATIONS (Specific gravity of mud 1.20)

Size (in)	Manufacturer	Type	Nominal pump flow (lpm)	Nominal torque (N.m)	Nominal speed (rpm)	Pressure drop (kPa)	Nominal output (kW)	Number of stages	Weight (daN)	Hole size (in)
4 3/4	Neyrfor Weir	T2AI	600	420	1 180	9 600	52	200	893	5 7/8 to 6 1/4
5	Neyrfor Weir	TFI	600	280	1 020	5 300	30	129	765	6 to 6 3/4
5	Neyrfor Weir	T2FI	600	540	1 020	9 700	58	258	1 256	6 to 6 3/4
5	Redi Drill	ST15	600	560	1 030	8 400	60	150	910	6 1/8 to 7 7/8
5	Redi Drill	ST25	600	900	1 030	14 000	97	240		6 1/8 to 7 7/8
5	Redi Drill	STD1-5	600	340	1 030	5 000	37	90	700	6 1/8 to 7 7/8
6 5/8	Neyrfor Weir	T2AI	1 600	1 820	1 100	12 600	210	172	1 888	8 3/8 to 9 7/8
6 5/8	Neyrfor Weir	T3AI	1 600	2 720	1 100	18 400	313	258	2 536	8 3/8 to 9 7/8
7 1/4	Neyrfor Weir	T2AI	1 800	1 970	880	10 400	182	164	2 160	8 3/8 to 9 7/8
7 1/4	Neyrfor Weir	T3AI	1 800	2 950	880	14 900	272	246	2 940	8 3/8 to 9 7/8
7 1/4	Neyrfor Weir	TFST	1 800	510	750	2 400	40	50	730	8 3/8 to 12 1/4
7 1/4	Neyrfor Weir	TFM	1 800	820	750	3 700	64	80	1 030	8 3/8 to 12 1/4
7 1/4	Neyrfor Weir	TF	1 800	1 130	750	5 000	89	100	1 390	8 3/8 to 12 1/4
7 1/4	Redi Drill	ST1	1 800	2 390	1 020	12 400	255	150	2 310	8 1/2 to 12 1/4
7 1/4	Redi Drill	ST2	1 800	3 500	1 020	18 200	374	220		8 1/2 to 12 1/4
7 1/4	Redi Drill	STD1	1 800	1 120	1 020	5 800	120	70	900	8 1/2 to 12 1/4
7 1/4	Redi Drill	STD2	1 800	1 590	1 020	8 300	170	100	1 380	8 1/2 to 12 1/4
9 1/2	Neyrfor Weir	T2AI	2 500	3 610	723	11 000	273	172	4 370	12 1/4 to 17 1/2
9 1/2	Neyrfor Weir	T3AI	2 500	5 420	723	15 700	410	258	5 935	12 1/4 to 17 1/2
10 1/4	Neyrfor Weir	TFST	3 000	2 060	630	4 700	136	79	2 260	14 3/4 to 26

lpm x 0.264 = gpm kW x 1.34 = hp N.m x 0.738 = lb.ft kPa x 0.145 = psi daN x 2.25 = lb

POSITIVE DISPLACEMENT MOTORS

I SPECIFICATIONS OF POSITIVE DISPLACEMENT MOTORS

Positive displacement motors are identified by:

- Outside diameter of the body
- Ratio of the shaft lobes (rotor) to the sleeve (stator) which may vary from 1/2 to 9/10:

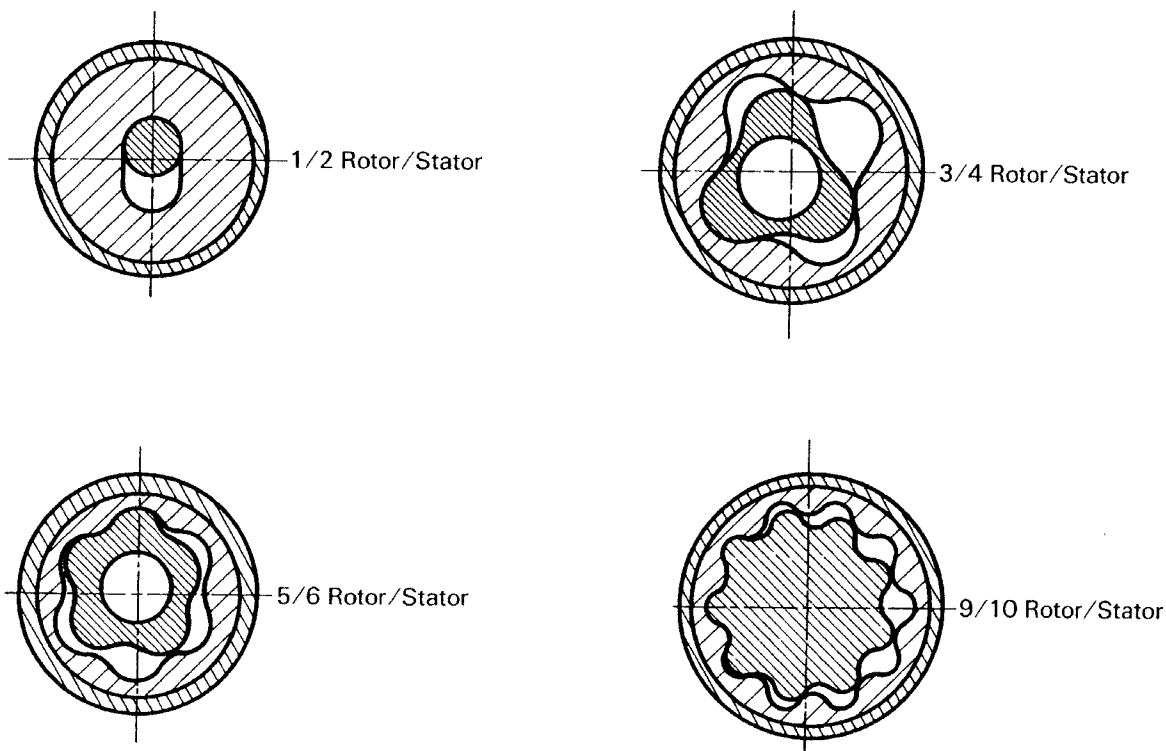

- Number of stages
- Length and weight.

The hydraulic characteristics are indicated by:

- Minimum and maximum flow rates
- Minimum and maximum rotary speeds
- Maximum pressure drop across the motor
- Maximum torque supplied
- Maximum mechanical horsepower output supplied
- Maximum efficiency.

II VARIATIONS IN SPECIFICATIONS

The specifications are given by the manufacturers for a specific gravity of 1.20 (10 ppg):

- The **rotary speed** is directly proportional to the flow rate:

$$N_2 = N_1 \frac{Q_2}{Q_1}$$

The higher the number of shaft lobes, the lower the rotary speed.

It varies only slightly with torque and pressure drop.

POSITIVE DISPLACEMENT MOTORS (continued)

- The **torque** is directly proportional to the pressure drop across the motor:

$$T_2 = T_1 \frac{\Delta p_2}{\Delta p_1}$$

- The **mechanical horsepower output** transmitted to the rotor is the product of the rotary speed multiplied by the torque:

$$P_m = \frac{TN}{9550}$$

- The **hydraulic horsepower** is the product of the pressure drop multiplied by the flow rate:

$$P_h = \frac{\Delta p Q}{60\,000}$$

where:

T = torque (in N.m)

N = rotary speed (in rpm)

Δp = pressure drop in the motor (in kPa)

Q = mud flow rate (in l/min)

P_h = hydraulic horsepower (in kW)

P_m = mechanical horsepower output at rotor (in kW)

The efficiency is the ratio:

$$\eta = \frac{P_m}{P_h}$$

$$\eta = 6.28 \frac{TN}{\Delta p Q}$$

Example: Halliburton 6 3/4 in F2000S

$$Q_{\max} = 1704 \text{ l/min} \quad T_{\max} = 5694 \text{ N.m}$$

$$\Delta P_{\max} = 4100 \text{ kPa} \quad N_{\max} = 170 \text{ rpm}$$

$$P_h = \frac{4100 \times 1704}{60\,000} = 116.4 \text{ kW}$$

$$P_m = \frac{5694 \times 170}{9550} = 101.3 \text{ kW}$$

$$\eta = \frac{101.3}{116.4} = 87\%$$

In fact the rotary speed slightly decreases with torque (see diagram E 25) and the real value of efficiency is lower than 87. With a torque of 5694 N.m, the rotary speed decreases to about 120 rpm (Halliburton Dyna-Drill handbook). Real efficiency is 61%.

PERFORMANCE CURVES OF POSITIVE DISPLACEMENT MOTORS FOR DIFFERENT FLOW RATES Q

Example of a 6 3/4" – 4/5 lobe Performance Curves:

Motor start pressure 100 psi (7 bar)

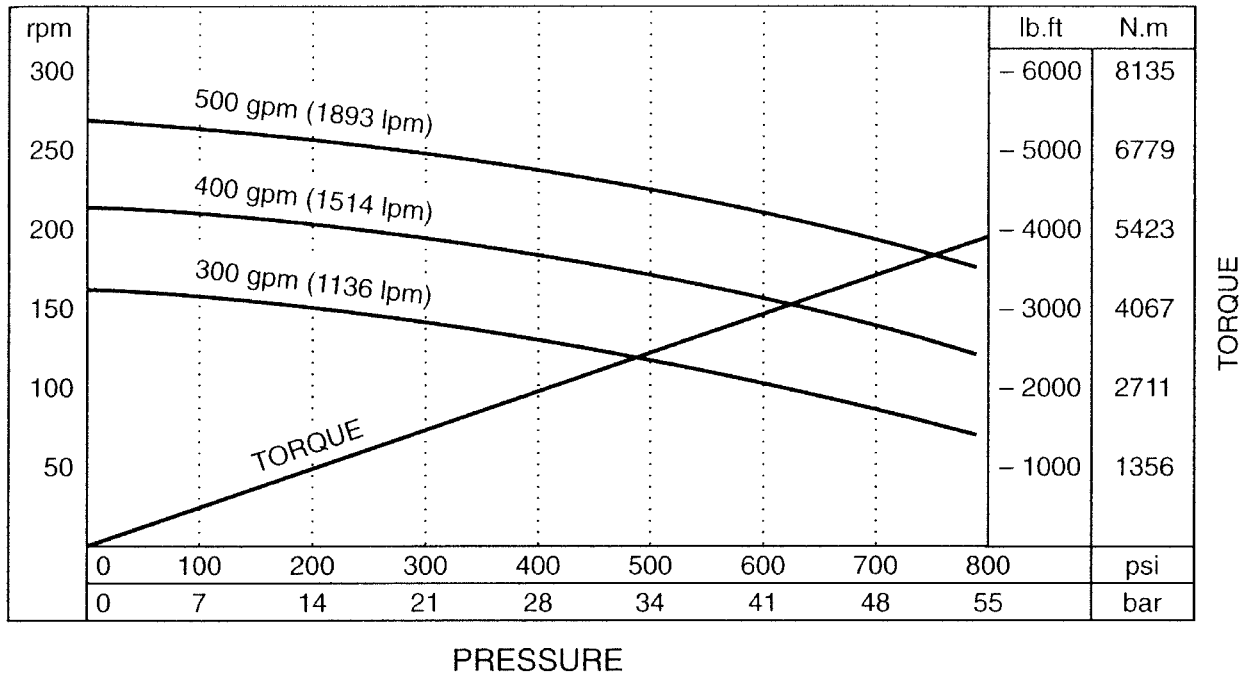

SPECIFICATIONS OF POSITIVE DISPLACEMENT MOTORS (Moineau type)

Size (in)	Manufacturer	Type	No. of lobes	Flow rate (l/min)		Rotary speed (rpm)		Maximum operating torque (N.m)	Maximum operating pressure drop (kPa)	Operating horse-power output (kW)	Overall Length (m)	Hole size (in)	
				Min.	Max.	Min.	Max.						
1 11/16	Drilex Halliburton	D170	3/4	38	83	645	1 435	52	5 500	8	2.26	1 7/8 to 2 3/4	
1 11/16		D170HF	5/6	83	159	365	700	102	3 500	7	2.38	1 7/8 to 2 3/4	
1 11/16		MS200H	3/4	38	83	645	1 435	52	5 500	8	2.26	1 7/8 to 2 3/4	
1 11/16		MS200HF	5/6	83	159	365	700	101	3 400	7	2.38	1 7/8 to 2 3/4	
2 1/8	Drilex	D212	5/6	114	159	580	850	163	5 200	15	2.78	2 1/4 to 3 1/2	
2 1/8		D212HF	5/6	95	246	230	600	204	5 200	13	3.14	2 1/4 to 3 1/2	
2 1/8		MS200M	5/6	114	159	580	850	163	5 200	15	2.78	2 1/4 to 3 1/2	
2 1/8		MS200HF	5/6	132	246	325	600	169	5 200	11	3.14	2 1/4 to 3 1/2	
2 3/8	Anadrill Schlum. Anadrill Schlum. Drilex	A238M	5/6	76	189	100	380	115	2 620	5	2.57	2 7/8 to 3 1/2	
2 3/8		A238M	5/6	76	189	100	400	292	5 378	12	3.81	2 7/8 to 3 1/2	
2 3/8		D237	5/6	114	159	580	850	163	5 200	15	2.78	2 7/8 to 3 1/2	
2 3/8		D237HF	5/6	151	303	300	600	251	3 500	16	2.87	2 7/8 to 3 1/2	
2 3/8		MS200M	5/6	114	159	580	850	163	5 200	15	2.71	2 7/8 to 3 1/2	
2 3/8		MS200HF	5/6	151	303	300	600	251	5 200	16	2.87	2 7/8 to 3 1/2	
2 3/4	Halliburton	D1000H	1/2	151	303	790	1 590	152	6 200	25	3.90	3 to 4 5/8	
2 7/8	Anadrill Schlum. Anadrill Schlum. Anadrill Schlum. Drilex	A287M	5/6	76	303	120	480	224	3 447	11	3.05	3 3/8 to 4 3/4	
2 7/8		A287XP	5/6	76	303	120	480	542	7 240	27	4.47	3 3/8 to 4 3/4	
2 7/8		A287M	7/8	76	303	75	300	278	3 620	9	3.05	3 3/8 to 4 3/4	
2 7/8		D287HS	7/8	151	341	285	642	360	5 200	24	2.32	3 1/4 to 4 1/2	
2 7/8		D287HF	7/8	227	473	200	415	542	2 600	24	2.59	3 1/4 to 4 1/2	
2 7/8		MS600M	7/8	189	473	145	360	278	2 600	10	2.83	3 1/4 to 4 3/4	
3 1/8		Baker Hughes Inteq	M1X		303	606	180	365	515	2 900	20	3.60	4 1/4 to 5 7/8
3 1/8		Baker Hughes Inteq	M1XL		303	606	180	365	976	5 900	37	4.50	4 1/4 to 5 7/8
3 1/2	Anadrill Schlum. Anadrill Schlum. Drilex	A350M	4/5	114	416	98	360	711	4 895	27	4.60	4 1/2 to 6	
3 1/2		A350M	7/8	114	416	48	180	746	3 378	14	4.60	4 1/2 to 6	
3 1/2		D350	9/10	303	416	290	400	542	3 400	23	3.14	3 7/8 to 4 3/4	
3 1/2		D350HS	7/8	151	341	285	642	359	5 200	24	3.45	3 7/8 to 4 3/4	
3 1/2		D350HF	5/6	284	606	175	375	881	3 400	35	3.69	3 7/8 to 4 3/4	
3 1/2		Halliburton	MS500M	5/6	303	606	180	360	881	3 400	33	3.65	3 7/8 to 4 3/4

l/min x 0.264 = gal/min N.m x 0.738 = lb.ft kPa x 0.145 = psi kW x 1.34 = hp m x 3.281 = ft

SPECIFICATIONS OF POSITIVE DISPLACEMENT MOTORS (continued) (Moineau type)

Size (in)	Manufacturer	Type	No. of lobes	Flow rate (l/min)		Rotary speed (rpm)		Maximum operating torque (N.m)	Maximum operating pressure drop (kPa)	Operating horse-power output (kW)	Overall Length (m)	Hole size (in)
				Min.	Max.	Min.	Max.					
3 3/4	Drilex	D375	5/6	341	586	320	530	786	5 200	44	3.60	4 3/4 to 6
3 7/8	Halliburton	D1000H	1/2	284	662	320	745	617	5 200	48	6.90	4 5/8 to 6
4 3/4	Anadrill Schlum.	A475M	1/2	379	757	225	450	556	2 586	26	5.74	5 7/8 to 7
4 3/4	Anadrill Schlum.	A475M	4/5	379	946	105	262	1 423	3 447	39	5.05	5 7/8 to 7
4 3/4	Anadrill Schlum.	A475XP	4/5	379	946	105	262	2 576	5 860	71	6.86	5 7/8 to 7
4 3/4	Anadrill Schlum.	A475M	7/8	379	946	56	140	1 220	2 482	18	5.05	5 7/8 to 7
4 3/4	Baker Hughes Inteq	M1X		379	1 192	110	325	1 844	4 900	63	5.70	6 to 7 7/8
4 3/4	Baker Hughes Inteq	M1XL		397	1 192	110	325	3 525	9 500	120	8.50	6 to 7 7/8
4 3/4	Baker Hughes Inteq	M2P/XL		303	1 003	180	600	1 966	11 000	124	8.50	6 to 7 7/8
4 3/4	Drilex	DIR475	5/6	379	946	140	350	1 288	3 400	47	3.17	6 to 7 7/8
4 3/4	Drilex	D475	5/6	379	946	140	350	2 441	5 200	89	5.76	6 to 7 7/8
4 3/4	Drilex	D475SS	7/8	379	946	60	165	2 847	3 400	49	5.76	6 to 7 7/8
4 3/4	Drilex	D475TPS	5/6	379	946	140	350	4 067	10 300	149	7.12	6 to 7 7/8
4 3/4	Halliburton	F2000S	5/6	681	946	95	125	1 898	2 100	25	6.50	5 7/8 to 7 7/8
4 3/4	Halliburton	F2000M	5/6	568	946	150	240	2 135	4 100	54	6.50	5 7/8 to 7 7/8
4 3/4	Halliburton	F2000H	1/2	568	1 136	350	550	949	3 100	55	7.80	5 7/8 to 7 7/8
4 3/4	Halliburton	F2000M-stand	5/6	568	946	150	240	2 989	5 800	75	9.51	5 7/8 to 7 7/8
4 3/4	Halliburton	F2000S-stand+	5/6	681	946	95	125	3 796	4 200	50	11.30	5 7/8 to 7 7/8
4 3/4	Halliburton	F2000M-stand+	5/6	568	946	150	240	4 271	8 400	107	11.30	5 7/8 to 7 7/8
4 3/4	Neyfor Weir	VM7000	7/8	380	950	55	134	1 956	2 500	27	5.20	5 3/4 to 6 1/2
4 3/4	Neyfor Weir	VM5000	1/2	380	757	310	670	569	3 450	40	5.83	5 3/4 to 6 1/2
5	Halliburton	D500	1/2	568	946	335	560	576	2 500	34	5.80	6 1/2 to 7 7/8
6 1/4	Drilex	D625SS	4/5	644	1 703	75	200	8 812	4 300	185	6.09	7 7/8 to 10 5/8
6 1/2	Halliburton	D500	1/2	757	1 325	275	480	935	2 500	47	6.00	8 3/8 to 9 7/8
6 1/2	Halliburton	F2000S	5/6	946	1 704	105	190	3 797	3 100	76	6.80	8 3/8 to 9 7/8
6 1/2	Halliburton	F2000H	1/2	946	1 514	350	550	1 817	4 100	105	7.60	8 3/8 to 9 7/8
6 1/2	Halliburton	F2000S-stand+	5/6	946	1 704	105	190	7 592	6 200	151	12.60	8 3/8 to 9 7/8
6 5/8	Neyfor Weir	VM7000	7/8	1135	2 280	86	172	5 204	3 500	94	5.88	8 3/8 to 9 7/8
6 5/8	Neyfor Weir	VM5000	1/2	757	1 892	200	500	1 851	3 500	97	7.15	8 3/8 to 9 5/8

l/min x 0.264 = gal/min N.m x 0.738 = lb.ft kPa x 0.145 = psi kW x 1.34 = hp m x 3.281 = ft

SPECIFICATIONS OF POSITIVE DISPLACEMENT MOTORS (continued)
(Moineau type)

Size (in)	Manufacturer	Type	No. of lobes	Flow rate (l/min)		Rotary speed (rpm)		Maximum operating torque (N.m)	Maximum operating pressure drop (kPa)	Operating horse-power output (kW)	Overall Length (m)	Hole size (in)
				Min.	Max.	Min.	Max.					
6 3/4	Anadrill Schlum.	A675M	1/2	757	1 893	180	465	1 790	3 447	87	7.19	8 3/8 to 9 7/8
6 3/4	Anadrill Schlum.	A675M	4/5	1 136	2 271	150	300	4 135	4 757	130	6.50	8 3/8 to 9 7/8
6 3/4	Anadrill Schlum.	A675XP	4/5	1 136	2 271	150	300	6 169	6 964	194	8.05	8 3/8 to 9 7/8
6 3/4	Anadrill Schlum.	A675M	7/8	1 136	2 271	86	165	4 000	3 378	69	5.89	8 3/8 to 9 7/8
6 3/4	Anadrill Schlum.	A675XP	7/8	1 136	2 271	86	170	7 457	5 585	133	7.67	8 3/8 to 9 7/8
6 3/4	Baker Hughes Inteq	M1X		1 003	2 498	90	220	3 647	4 400	84	7.00	8 3/8 to 9 7/8
6 3/4	Baker Hughes Inteq	M1XL		1 003	2 498	90	220	6 847	5 900	158	9.60	8 3/8 to 9 7/8
6 3/4	Baker Hughes Inteq	M2P/XL		1 003	2 006	235	470	3 593	7 900	177	9.60	8 3/8 to 9 7/8
6 3/4	Drilex	DIR675	9/10	1 136	2 461	85	185	6 101	2 600	118	4.00	7 7/8 to 9 7/8
6 3/4	Drilex	D675SS	9/10	757	2 461	55	185	8 135	3 400	158	6.25	7 7/8 to 10 5/8
6 3/4	Drilex	D675MS	6/7	757	1 514	159	318	3 254	4 300	108	7.53	7 7/8 to 10 5/8
6 3/4	Drilex	D675TPS	9/10	757	2 461	55	185	10 850	6 900	210	8.96	7 7/8 to 10 5/8
6 3/4	Halliburton	F2000S	5/6	946	1 704	95	170	5 694	4 100	101	7.30	8 3/8 to 9 7/8
6 3/4	Halliburton	F2000M	4/5	1 135	1 893	165	265	5 084	5 200	141	7.60	8 3/8 to 9 7/8
6 3/4	Halliburton	F2000MX	4/5	1 628	2 461	211	319	7 699	6 200	257	9.13	8 3/4 to 9 7/8
6 3/4	Halliburton	F2000S-tand	5/6	946	1 704	95	170	7 972	5 800	142	11.60	8 3/8 to 9 7/8
6 3/4	Halliburton	F2000M-tand	4/5	1 135	1 893	165	265	7 117	7 200	197	11.60	8 3/8 to 9 7/8
7 5/8	Drilex	DIR775	9/10	1 136	2 461	85	185	6 101	2 600	118	4.00	9 7/8 to 14 3/4
7 5/8	Drilex	D775SS	9/10	757	2 461	55	185	8 135	3 400	158	6.44	9 7/8 to 14 3/4
7 5/8	Drilex	D775TPS	9/10	757	2 461	55	185	10 850	6 900	210	8.96	9 7/8 to 14 3/4
7 3/4	Halliburton	D500	1/2	1 135	1 704	275	415	1 532	2 500	67	6.20	9 7/8 to 12 1/4
7 3/4	Halliburton	F2000S	7/8	1 136	2 271	90	185	10 305	4 700	164	7.00	9 7/8 to 12 1/4
7 3/4	Halliburton	F2000H	1/2	1 136	1 893	230	390	2 928	4 100	120	8.00	9 7/8 to 12 1/4
7 3/4	Halliburton	F2000S-tand	7/8	1 135	2 271	90	185	11 862	6 500	230	10.50	9 7/8 to 12 1/4
8	Anadrill Schlum.	A800M	1/2	1 136	2 271	210	420	2 304	3 447	101	7.87	9 7/8 to 14 3/4
8	Anadrill Schlum.	A800M	4/5	1 136	2 271	75	225	5 437	3 585	128	7.19	9 7/8 to 14 3/4
8	Anadrill Schlum.	A800XP	4/5	1 136	2 271	75	225	8 203	5 240	193	8.92	9 7/8 to 14 3/4
8	Anadrill Schlum.	A800M	7/8	1 136	2 271	48	145	6 101	3 309	93	7.19	9 7/8 to 14 3/4
8	Anadrill Schlum.	A800XP	7/8	1 136	2 271	48	145	8 813	4 482	134	8.41	9 7/8 to 14 3/4
8	Neyrfor Weir	VM7000	7/8	1 135	3 410	50	145	9 367	3 400	142	6.69	9 1/2 to 12 1/4
8	Neyrfor Weir	VM5000	1/2	1 135	2 270	210	420	2 487	3 400	109	7.38	9 1/2 to 12 1/4
8	Halliburton	F2000MX	5/6	2 271	3 407	149	223	13 825	6 200	323	9.13	9 7/8 to 12 1/4

l/min x 0.264 = gal/min N.m x 0.738 = lb.ft kPa x 0.145 = psi kW x 1.34 = hp m x 3.281 = ft

SPECIFICATIONS OF POSITIVE DISPLACEMENT MOTORS (continued) (Moineau type)

Size (in)	Manufacturer	Type	No. of lobes	Flow rate (l/min)		Rotary speed (rpm)		Maximum operating torque (N.m)	Maximum operating pressure drop (kPa)	Operating horse-power output (kW)	Overall Length (m)	Hole size (in)	
				Min.	Max.	Min.	Max.						
8 1/4	Drilex Halliburton Halliburton	D825SS	9/10	757	2 461	55	185	8 135	3 400	158	6.62	9 7/8 to 14 3/4	
8 1/4		D825HF	5/6	1 325	2 839	110	235	9 491	4 300	234	7.47	9 7/8 to 14 3/4	
8 1/4		F2000S	5/6	1 893	3 028	115	180	8 950	4 100	169	7.50	9 7/8 to 12 1/4	
8 1/4		F2000S-tand	7/8	1 135	2 271	90	185	11 682	6 500	226	10.50	9 7/8 to 12 1/4	
9 1/2	Baker Hughes Inteq Drilex Drilex Drilex Neyfor Weir Neyfor Weir Neyfor Weir	M1XL		2 006	4 012	80	165	14 602	5 900	252	10.70	12 1/4 to 17 1/2	
9 1/2		D950	10/11	1 893	3 218	110	190	10 169	3 400	202	6.50	12 1/4 to 17 1/2	
9 1/2		D950MS	5/6	1 352	2 839	110	235	9 491	4 300	234	7.35	12 1/4 to 17 1/2	
9 1/2		D950HF	7/8	2 650	4 164	115	180	13 558	3 400	256	8.69	12 1/4 to 36	
9 1/2		VM7000	5/6	2 270	4 540	67	134	12 916	3 100	181	8.94	12 1/4 to 26	
9 1/2		VM7000	3/4	2 270	4 540	133	266	9 475	4 280	264	8.94	12 1/4 to 26	
9 1/2	VM5000	1/2	1 495	3 028	200	400	4 500	4 150	188	9.84	12 1/4 to 17 1/2		
9 5/8	Anadrill Schlum. Anadrill Schlum. Anadrill Schlum. Anadrill Schlum. Anadrill Schlum. Halliburton Halliburton Halliburton Halliburton Halliburton Halliburton Halliburton Anadrill Schlum. Neyfor Weir Halliburton	A962M	1/2	1 514	3 028	190	380	4 610	4 413	183	8.89	12 1/4 to 26	
9 5/8		A962M	3/4	2 271	4 542	133	266	8 813	4 309	245	8.00	12 1/4 to 26	
9 5/8		A962XP	3/4	2 271	4 542	133	266	11 263	5 688	313	9.27	12 1/4 to 26	
9 5/8		A962M	5/6	2 271	4 542	67	134	10 847	3 103	152	8.00	12 1/4 to 26	
9 5/8		A962XP	5/6	2 271	4 542	67	134	15 050	4 137	211	9.27	12 1/4 to 26	
9 5/8		D500	1/2	1 514	2 650	215	375	2 623	2 500	103	7.70	12 1/4 to 17 1/2	
9 5/8		F2000S	5/6	3 028	4 542	90	140	10 575	2 600	155	7.80	12 1/4 to 26	
9 5/8		F2000M	5/6	2 271	3 407	115	170	10 539	4 100	188	7.80	12 1/4 to 26	
9 5/8		F2000H	1/2	2 271	3 785	240	400	6 236	4 100	261	9.10	12 1/4 to 26	
9 5/8		F2000MX	5/6	3 028	4 921	110	178	21 842	5 200	407	9.61	12 1/4 to 26	
9 5/8		F2000M-tand	5/6	2 271	3 407	115	170	14 944	5 800	266	11.80	12 1/4 to 26	
9 5/8		F2000S-tand+	5/6	3 028	4 542	90	140	21 150	5 200	310	13.90	12 1/4 to 26	
11 1/4		Anadrill Schlum. Neyfor Weir	A1125M	3/4	3 785	5 678	115	170	13 558	3 378	241	8.84	17 1/2 to 26
11 1/4			VM7000	3/4	3 780	5 670	120	180	15 010	3 500	283	9.63	15 to 26
12	Halliburton	D500	1/2	3 028	4 542	125	188	8 677	2 500	171	10.10	17 1/2 to 26	

l/min x 0.264 = gal/min N.m x 0.738 = lb.ft kPa x 0.145 = psi kW x 1.34 = hp m x 3.281 = ft

F

hoisting and derrick floor equipment

Hoisting mechanics. Reeving function.....	F1
Hoisting mechanics. Power.....	F2
API wire rope. Factor of safety (RP 9B, May 30, 1986)..	F3-F4
API wire rope.....	F5
Typical sizes and constructions of wire rope.....	F6-F7
API classification of bright (uncoated) or drawn galvanized wire rope. Class 6 x 7. Fiber Core (FC) (API Spec 9A, 24 th edition, June 1, 1995).....	F8
API classification of bright (uncoated) or drawn galvanized wire rope. Classes 6 x 19 and 6 x 37. Fiber Core (FC) (API Spec 9A, 24 th edition, June 1, 1995).....	F9
API classification of bright (uncoated) or drawn galvanized wire rope (continued). Class 6 x 19. Independent Wire Rope Core (IWRC) (API Spec 9A, 24 th edition, June 1, 1995).....	F10
API classification of bright (uncoated) or drawn galvanized wire rope (continued). Class 6 x 37. Independent Wire Rope Core (IWRC) (API Spec 9A, 24 th edition, June 1, 1995).....	F11
API classification of bright (uncoated) or drawn galvanized wire rope (continued). Configurations (API Spec 9A, 24 th edition, June 1, 1995).....	F12-F13

API classification of bright (uncoated) or drawn galvanized wire rope (continued). Class 6 x 61. Independent Wire Rope Core (IWRC) (API Spec 9A, 24 th edition, June 1, 1995).....	F14
API classification of bright (uncoated) or drawn galvanized wire rope (continued). Class 6 x 91. Independent Wire Rope Core (IWRC) (API Spec 9A, 24 th edition, June 1, 1995).....	F15
API classification of bright (uncoated) or drawn galvanized wire rope (continued). Class 8 x 19. Independent Wire Rope Core (IWRC) (API Spec 9A, 24 th edition, June 1, 1995).....	F16
API classification of bright (uncoated) or drawn galvanized wire rope (continued). Class 18 x 7. Fiber Core (FC). (API Spec 9A, 24 th edition, June 1, 1995).....	F17
API classification of bright (uncoated) or drawn galvanized wire rope (continued). Class 19 x 7. Metal Core. (API Spec 9A, 24 th edition, June 1, 1995).....	F18
API classification of bright (uncoated) or drawn galvanized wire rope (continued). Classes 6 x 25 "B", 6 x 27 "H", 6 x 30 "G" and 6 x 31 "V" (API Spec 9A, 24 th edition, June 1, 1995).....	F19
API wire rope. Sheave sizes (API RP 9B, May 30, 1986).....	F20
Sheave grooves. (API Spec 8A, 12 th edition, June 1, 1992).....	F21
Work done by a drilling line.....	F22
Cutoff practice for drilling lines. Cutoff length as a function of derrick or mast height and drum diameter (API RP 9B, 9 th edition, may 30, 1986).....	F23
Cutoff practice for drilling lines (continued). Cumulative work before first cut-off (API RP 9B, 9 th edition, May 30, 1986).....	F24

Drum and reel capacity (from IADC Drilling Manual).....	F25
Elevator link arms. Remaining capacities of work link arms. Dimensions and nominal capacity of link arms (per set).....	F26
Recommended hoisting tool contact surface radii (API Spec 8A, 12 th edition, June 1, 1992).....	F27-F29
Drill pipe elevators bores (API Spec 8A, 12 th edition, June 1, 1992).....	F30
Brake blocks.....	F31
Vibrator and drilling hose (API Spec 7K, 2 nd edition, February, 1996).....	F32-F33
Chains (API Standard 7F, 5 th edition, October 1, 1993)....	F34
Chains (continued). Standard chain dimensions (ANSI Standard, B29.1).....	F35
Chains (continued).....	F36
Rotary table opening and square drive master bushing (API Spec 8C, 2 nd edition, June 1, 1992).....	F37
Four-pin drive Kelly bushing and master bushing (API Spec 8C, 2 nd edition, June 1, 1992).....	F38
Tension in slings. Two-wire slings.....	F39

HOISTING MECHANICS

Reeving function

F = hook load (t)
 N = number of lines
 t = dead line tension (t)
 t_a = fast line tension (t)

$$t = \frac{F}{N}$$

in static conditions $\left\{ \begin{array}{l} t_a = t \\ \text{in dynamic conditions } \left\{ \begin{array}{l} t_a = \frac{t}{\eta_m} \end{array} \right. \end{array} \right.$

η_m = reeving efficiency (see F 3)
 V_c = hook speed (m/s)
 V_t = fast line speed (m/s)

$$V_t = V_c N$$

R = winch speed of rotation (rpm)
 D = winch spooling diameter (m)

$$R = \frac{60 V_t}{\pi D}$$

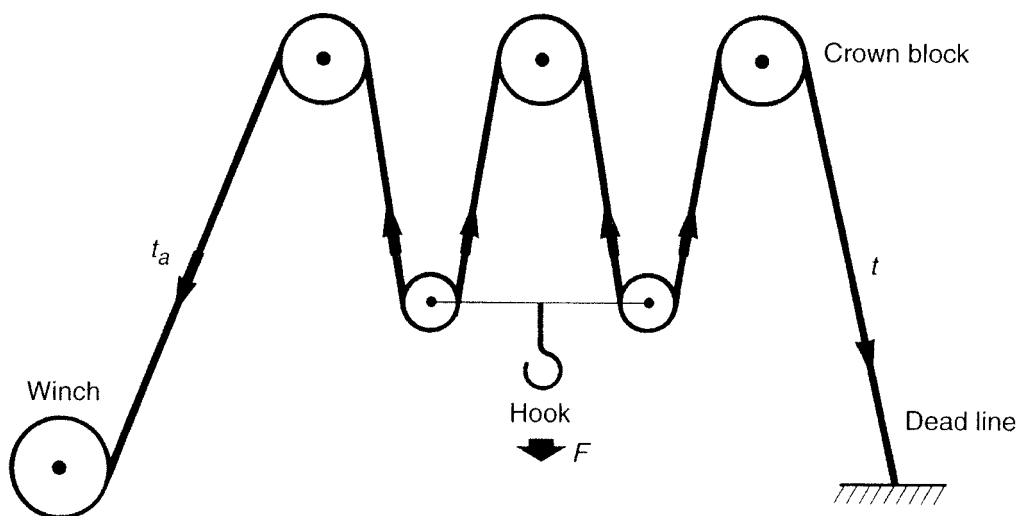

HOISTING MECHANICS

Power

I POWER DEVELOPED AT HOOK

$$P_c = FV_c$$

P_c = power on hook (W)

F = hook load (N)

V_c = hook speed (m/s)

$$P_c (\text{kW}) = \frac{F (\text{kg}) \times V_c (\text{m/s})}{102}$$

$$P_c (\text{hp}) = \frac{F (\text{kg}) \times V_c (\text{m/s})}{76}$$

$$P_c (\text{hp}) = \frac{F (\text{lb}) \times V_c (\text{ft/s})}{550}$$

II POWER CONSUMED AT WINCH

$$P_t = t_a V_t$$

P_t = winch power (W)

t_a = fast line tension (N)

V_t = fast line speed (m/s)

t = dead line tension (N)

$$P_t = \frac{t}{\eta_m} V_c N = \frac{FV_c}{\eta_m}$$

$$P_t = \frac{FV_c}{\eta_m}$$

F = hook load (N)

V_c = hook speed (m/s)

η_m = reeving efficiency

III TORQUE CONSUMPTION AT WINCH

$$M = \frac{P_t}{R}$$

M = winch torque (m·N)

R = speed of rotation (rad/s)

$$M (\text{m.daN}) = \frac{955 P_t (\text{kW})}{R (\text{rpm})}$$

$$M (\text{ft.lb}) = \frac{5252 P_t (\text{hp})}{R (\text{rpm})}$$

API WIRE ROPE

Factor of safety (RP 9B, May 30, 1986)

I DEFINITION OF FACTOR OF SAFETY

$$f = \frac{T}{t_a}$$

f = factor of safety
 T = wire rope breaking load (t)
 t_a = fast line tension (t)

II MINIMUM FACTOR OF SAFETY

Cable rig	3
Sand line	3
Rotary drilling line.....	3
Hoisting other than drilling line.....	3
Mast raising line.....	2.5
Drilling line when running in casing.....	2
Extra pull for unsticking or other occasional operations.....	2

III CALCULATION OF FAST LINE TENSION

$$t_a = \frac{F}{N\eta_m}$$

F = hook load (t)
 t_a = fast line tension (t)
 N = number of lines
 η_m = reeving efficiency

Reeving efficiency

Friction factor \ N	2	4	6	8	10	12	14
K = 1.09 Plain bearings	0.880	0.810	0.748	0.692	0.642	0.597	0.556
K = 1.04 Roller bearings	0.943	0.907	0.874	0.842	0.811	0.782	0.755

$$\eta_m = \frac{K^N - 1}{N(K - 1)K^N}$$

API WIRE ROPE (continued)
Factor of safety (RP 9B, May 30, 1986)

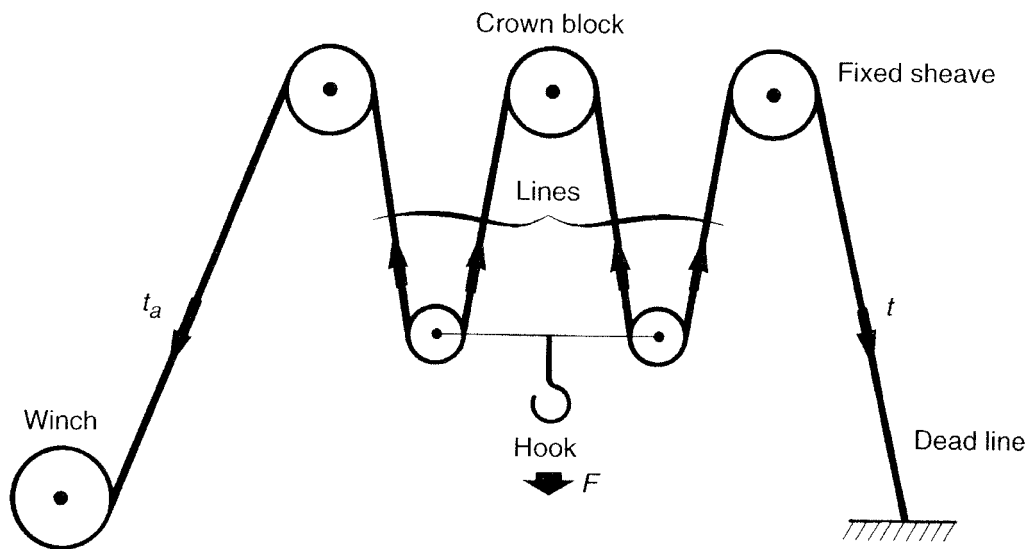

IV EXAMPLE OF APPLICATION

The hoisting equipment is reeved with eight lines: $N = 8$.

The hook load is 150 t.

The drilling line is: 1 1/4, 6 × 19 IWRC, EIPS with breaking load $T = 72.5$ t.

The sheaves have bearings, thus $K = 1.04$ or sheave efficiency η_P :

$$\eta_P = \frac{1}{1.04}$$

$$t_a = \frac{P}{N \times \eta_m} = \frac{150}{8 \times 0.842} = 22.27 \text{ t}$$

$$f = \frac{T}{t_a} = \frac{72.5}{22.27} = 3.26$$

Remark: if idler sheaves are placed between the drilling winch and the crown block, the fast line tension must be multiplied by the friction factor ($K = 1.04$) as many times as the number of sheaves:

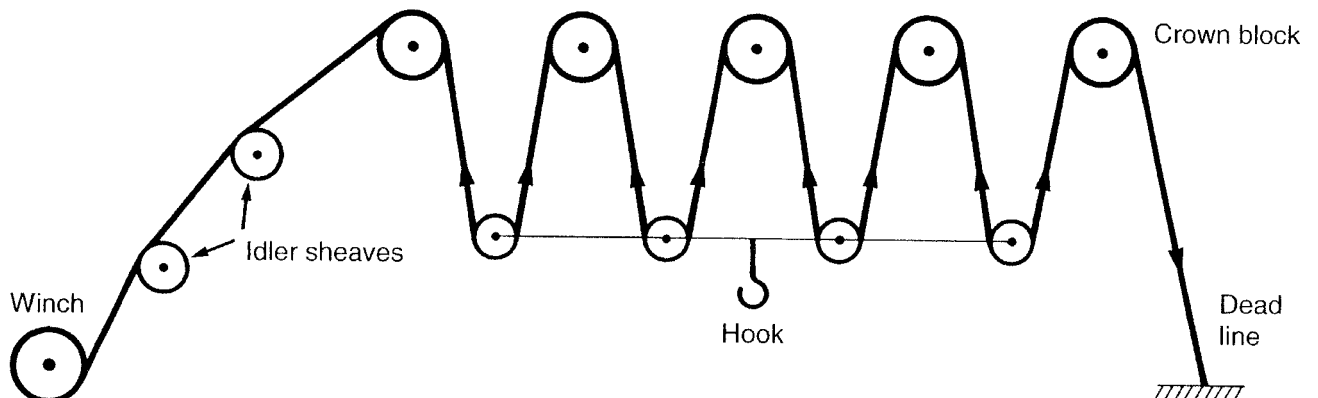

$t_a = 22.27 \times 1.04 \times 1.04 = 24$ t. The factor of safety becomes: $\frac{72.5}{24} = 3.01$.

API WIRE ROPE

I DEFINITIONS AND USUAL ABBREVIATIONS

W	Warrington	The outside layer contains filling wires
S	Seale	All layers contain the same number of wires
WS	Warrington-Seale	Mixed strand, Warrington inside and Seale outside
FS	Flattened Strand	Flat Strand
FW	Filler Wire	Inner layer with filler wires
PS	Plow Steel	Steel with breaking strength between 1570 and 1760 MPa
IPS	Improved Plow Steel	Steel with breaking strength between 1770 and 1960 MPa
EIPS	Extra Improved Plow Steel	Steel with breaking strength between 1970 and 2150 MPa
PF	Preformed	Preformed wires
NPF	Non Preformed	Non preformed wires
RL	Right Lay	Normal (regular) right lay: the strands are twisted to the right and the wires to the left
LL	Left Lay	Normal (regular) right lay: the strands are twisted to the left and the wires to the right
FC	Fiber Core	Fiber core
IWRC	Independant Wire Rope Core	Independant wire rope core

II TYPICAL STRAND CONSTRUCTION

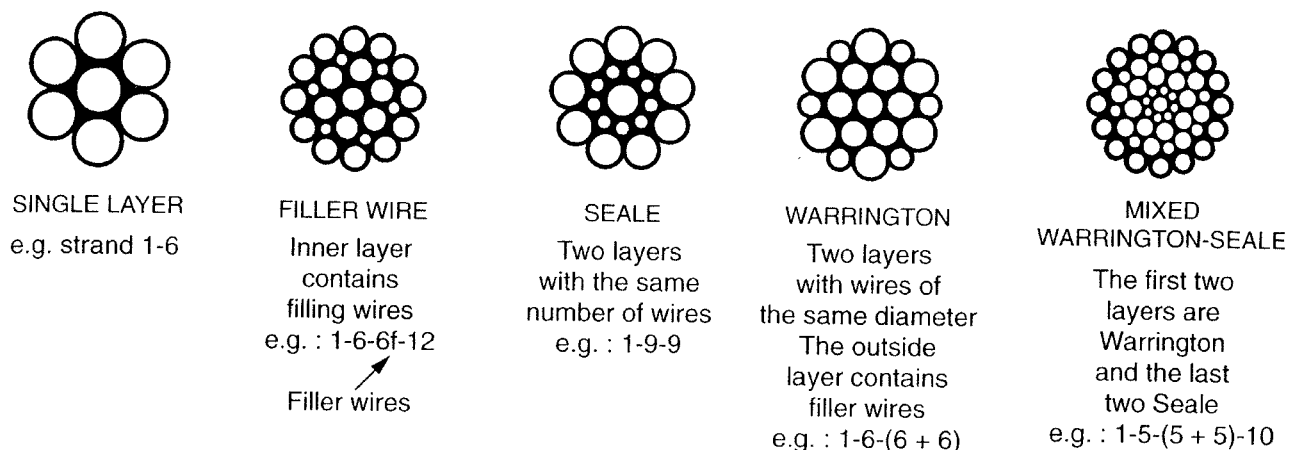

III DIFFERENT KINDS OF WIRE ROPE TWISTING

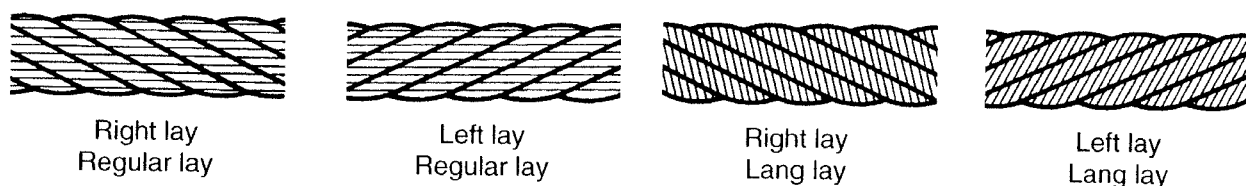

In ropes with "regular" lay the wires are twisted in one direction and the strands in the opposite direction.

In ropes with "lang" lay the wire and the strands are twisted in the same direction.

TYPICAL SIZES AND CONSTRUCTIONS OF WIRE ROPE

Service and well depth	Wire rope diameter (in)	Wire rope description (regular lay)
Rod and tubing pull lines: Shallow Intermediate Deep	1/2 to 3/4 incl. 3/4 to 7/8 7/8 to 1 1/8 incl.	6 x 25 FW or 6 x 26 WS or 6 x 31 WS or 18 x 7 (1) or 19 x 7 (1), PF, LL (1), IPS or EIPS, IWRC
Rod hanger lines	1/4	6 x 19, PF, RL, IPS, FC
Sand lines: Shallow Intermediate Deep	1/4 to 1/2 incl. 1/2, 9/16 9/16, 5/8	6 x 7 Bright or Galv (2), PF, RL, PS or IPS, FC
Drilling lines. Cable tool (drilling and cleanout): Shallow Intermediate Deep	5/8, 3/4 3/4, 7/8 7/8, 1	6 x 21 FW, PF or NPF, RL or LL, PS or IPS, FC
Casing lines. Cable tool: Shallow Intermediate Deep	3/4, 7/8 7/8, 1 1, 1 1/8	6 x 25 FW or 6 x 26 WS, PF, RL, IPS or EIPS, FC or IWRC
Drilling lines. Coring and slim hole rotary rigs: Shallow Intermediate	7/8, 1 1, 1 1/8	6 x 26 WS, PF, RL, IPS or EIPS, IWRC 6 x 19 S or 6 x 26 WS, PF, RL, IPS or EIPS, IWRC

(1) Single line pulling of rods and tubing requires left lay construction or 18 x 7 or 19 x 7 construction.
 (2) Bright wire sand lines are regularly furnished; galvanized finish is sometimes required.

TYPICAL SIZES AND CONSTRUCTIONS OF WIRE ROPE (continued)

Service and well depth	Wire rope diameter (in)	Wire rope description (regular lay)
Drilling lines. Rotary rigs: Shallows Intermediate Deep	1, 1 1/8 1 1/8, 1 1/4 1 1/4 to 1 3/4	6 x 19 S or 6 x 21 S or 6 x 25 FW or FS, PF, RL, IPS or EIPS, IWRC
Winch lines. Heavy duty	5/8 to 7/8 7/8 to 1 1/8 incl.	6 x 26 WS or 6 x 31 WS, PF, RL, IPS or EIPS, IWRC 6 x 36 WS, PF, RL, IPS or EIPS, IWRC
Horsehead pumping. Unit lines: Shallow Intermediate	1/2 to 1 1/8 incl. (4) 5/8 to 1 1/8 incl. (3)	6 x 19 Class or 6 x 37 Class or 19 x 7 PF, IPS, FC or IWRC 6 x 19 Class or 6 x 37 Class, PF, IPS, FC or IWRC
Offshore anchorage lines	7/8 to 2 3/4 incl. 1 3/8 to 4 3/4 incl. 3 3/4 to 4 3/4 incl.	6 x 19 Class, Bright or Galv., PF, RL, IPS or EIPS, IWRC 6 x 37 Class, Bright or Galv., PF, RL, IPS or EIPS, IWRC 6 x 61 Class, Bright or Galv., PF, RL, IPS or EIPS, IWRC
Mast raising lines (5)	1 3/8 and smaller 1 1/2 and larger	6 x 19 Class, PF, RL, IPS or EIPS, IWRC 6 x 37 Class, PF, RL, IPS or EIPS, IWRC
Guideline tensioner line	3/4	6 x 25 FW, PF, RL, IPS or EIPS, IWRC
Riser tensioner lines	1 1/2, 2	(Lang lay): 6 x 37 Class or PF, RL, IPS or EIPS, IWRC

(3) Applies to pumping units having one piece of wire rope looped over an ear on the horsehead and both ends fastened to a polished-rod equalizer yoke.
 (4) Applies to pumping units having two vertical lines (parallel) with sockets at both ends of each line.
 (5) See API Spec 4E

**API CLASSIFICATION OF BRIGHT (UNCOATED)
OR DRAWN GALVANIZED WIRE ROPE**
Class 6 × 7. Fiber Core (FC)
(API Spec 9A, 24th edition, June 1, 1995)

Nominal diameter		Approximate weight			Breaking strength					
					Plow Steel (PS)			Improved Plow Steel (IPS)		
(in)	(mm)	(lb/ft)	(kg/m)	(lb)	(kN)	(t)	(lb)	(kN)	(t)	
3/8	9.5	0.21	0.31	10 200	45.7	4.6	11 720	53	5.3	
7/16	14.5	0.29	0.43	13 800	61.9	6.3	15 860	71	7.2	
1/2	12.7	0.38	0.57	17 920	80.3	8.1	20 600	92	9.3	
9/16	14.3	0.48	0.71	22 600	101.3	10.3	26 000	117	11.8	
5/8	15.9	0.59	0.88	27 800	124.6	12.6	31 800	143	14.4	
3/4	19.1	0.84	1.25	39 600	177.5	18.0	45 400	203	20.6	
7/8	22.2	1.15	1.71	53 400	239.3	24.2	61 400	275	27.9	
1	25.4	1.50	2.23	69 000	309.3	31.3	79 400	356	36.0	

Note: The strength of galvanized wire rope is 10% less than the figures given in this table.

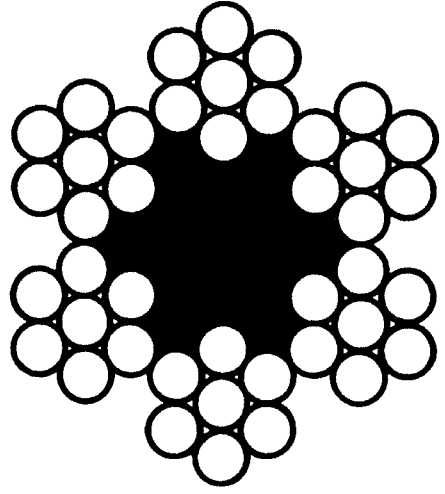

Rope configuration 6 x 7

**API CLASSIFICATION OF BRIGHT (UNCOATED)
OR DRAWN GALVANIZED WIRE ROPE (continued)**
Classes 6 × 19 and 6 × 37. Fiber Core (FC)
(API Spec 9A, 24th edition, June 1, 1995)

Nominal diameter		Approximate weight		Breaking strength											
				Plow Steel (PS)				Improved Plow Steel (IPS)				Extra Improved Plow Steel			
(in)	(mm)	(lb/ft)	(kg/m)	(lb)	(kN)	(t)	(lb)	(kN)	(t)	(lb)	(kN)	(t)	(lb)	(kN)	(t)
1/2	12.7	0.42	0.63	18 700	84	8.5	21 400	96	9.7	23 600	105	10.7	29 800	132	13.5
9/16	14.5	0.53	0.79	23 600	106	10.7	27 000	121	12.2	36 600	163	16.6	41 400	186	18.8
5/8	15.9	0.66	0.98	29 000	130	13.2	33 400	150	15.2	47 600	213	21.6	64 400	289	29.2
3/4	19.1	0.95	1.41	41 400	186	18.8	47 600	213	21.6	70 800	315	32.1	92 000	409	41.7
7/8	22.2	1.29	1.92	56 000	251	25.4	64 400	289	29.2	105 200	472	47.7	115 600	514	52.4
1	25.4	1.68	2.50	72 800	326	33.0	83 600	375	37.9	129 200	579	58.6	142 200	632	64.5
1 1/8	28.6	2.13	3.17	91 400	410	41.5	105 200	472	47.7	155 400	697	70.5	171 000	760	77.6
1 1/4	31.8	2.63	3.91	112 400	504	51.0	129 200	579	58.6	184 000	825	83.5	202 000	898	91.6
1 3/8	34.9	3.18	4.73				155 400	697	70.5	214 000	959	97.1	236 000	1050	107.0
1 1/2	38.1	3.78	5.63				184 000	825	83.5	248 000	1112	112.5	274 000	1220	124.0
1 5/8	41.3	4.44	6.61				214 000	959	97.1	282 000	1264	127.9	312 000	1390	142.0
1 3/4	44.5	5.15	7.66				248 000	1112	112.5	320 000	1434	145.2	352 000	1560	160.0
1 7/8	47.6	5.91	8.80				282 000	1264	127.9						
2	50.8	6.72	10.00				320 000	1434	145.2						

Note: The strength of galvanized wire rope is 10% less than the figures given in this table.

**API CLASSIFICATION OF BRIGHT (UNCOATED)
OR DRAWN GALVANIZED WIRE ROPE (continued)
Class 6 × 19. Independent Wire Rope Core (IWRC)
(API Spec 9A, 24th edition, June 1, 1995)**

Nominal diameter		Approximate weight		Breaking strength											
				Improved Plow Steel				Extra Improved Plow Steel				Extra Improved Plow Steel			
(in)	(mm)	(lb/ft)	(kg/m)	(lb)	(kN)	(t)	(lb)	(kN)	(t)	(lb)	(kN)	(t)	(lb)	(kN)	(t)
1/2	12.7	0.46	0.68	23 000	103	10.4	26 600	119	12.1	29 200	131	13.2	29 200	131	13.2
9/16	14.3	0.59	0.88	29 000	130	13.2	33 600	151	15.2	37 000	166	16.8	37 000	166	16.8
5/8	15.9	0.72	1.07	35 800	160	16.2	41 200	185	18.7	45 400	203	20.6	45 400	203	20.6
3/4	19.1	1.04	1.55	51 200	229	23.2	58 800	264	26.7	64 800	290	29.4	64 800	290	29.4
7/8	22.2	1.42	2.11	69 200	310	31.4	79 600	357	36.1	87 600	393	39.7	87 600	393	39.7
1 1/8	25.4	1.85	2.75	89 800	403	40.7	103 400	463	46.9	113 800	510	51.6	113 800	510	51.6
1 1/4	28.6	2.34	3.48	113 000	506	51.3	130 000	583	59.0	143 000	641	64.9	143 000	641	64.9
1 3/8	31.8	2.89	4.30	138 800	622	63.0	159 800	716	72.5	175 800	788	79.7	175 800	788	79.7
1 1/2	34.9	3.50	5.21	167 000	749	75.8	192 000	861	87.1	212 000	950	96.2	212 000	950	96.2
1 5/8	38.1	4.16	6.19	197 800	887	89.7	228 000	1 022	103.0	250 000	1 121	113.0	250 000	1 121	113.0
1 3/4	41.3	4.88	7.26	230 000	1 031	104.0	264 000	1 183	120.0	292 000	1 309	132.0	292 000	1 309	132.0
1 7/8	44.5	5.67	8.44	266 000	1 192	121.0	306 000	1 372	139.0	338 000	1 515	153.0	338 000	1 515	153.0
2	47.6	6.50	9.67	304 000	1 363	138.0	348 000	1 560	158.0	384 000	1 721	174.0	384 000	1 721	174.0
	50.8	7.39	11.00	344 000	1 542	156.0	396 000	1 775	180.0	434 000	1 945	197.0	434 000	1 945	197.0

Note: The strength of galvanized wire rope is 10% less than the figures given in this table.

**API CLASSIFICATION OF BRIGHT (UNCOATED)
OR DRAWN GALVANIZED WIRE ROPE (continued)
Class 6 × 37. Independent Wire Rope Core (IWRC)
(API Spec 9A, 24th edition, June 1, 1995)**

Nominal diameter		Approximate weight		Breaking strength											
				Improved Plow Steel				Extra Improved Plow Steel				Extra Improved Plow Steel			
(in)	(mm)	(lb/ft)	(kg/m)	(lb)	(kN)	(t)	(lb)	(kN)	(t)	(lb)	(kN)	(t)	(lb)	(kN)	(t)
1/2	12.7	0.46	0.68	23 000	103	10.4	26 000	117	11.8	29 200	131	13.2	37 000	166	16.8
9/16	14.3	0.59	0.88	29 000	130	13.2	33 600	151	15.2	45 400	203	20.6	58 800	264	29.4
5/8	15.9	0.72	1.07	35 800	160	16.2	41 200	185	18.7	64 800	290	29.4	87 600	393	39.7
3/4	19.1	1.04	1.55	51 200	229	23.2	58 800	264	26.7	113 800	510	51.6	143 000	641	64.9
7/8	22.2	1.42	2.11	69 200	310	31.4	79 600	357	36.1	175 800	788	79.7	212 000	950	96.2
1	25.4	1.85	2.75	89 800	403	40.7	103 400	463	46.9	250 000	1 121	113.0	338 000	1 515	153.0
1 1/8	28.6	2.34	3.48	113 000	506	51.3	130 000	583	59.0	384 000	1 721	174.0	488 000	2 187	221.0
1 1/4	31.8	2.89	4.30	138 800	622	63.0	159 800	716	72.5	544 000	2 438	247.0	664 000	2 976	301.0
1 3/8	34.9	3.50	5.21	167 000	749	75.8	192 000	861	87.1	728 000	3 263	330.0	864 000	3 873	392.0
1 1/2	38.1	4.16	6.19	197 800	887	89.7	228 000	1 022	103.0	936 000	4 195	425.0	1 010 000	4 527	458.0
1 5/8	41.3	4.88	7.26	230 000	1 031	104.0	264 000	1 183	120.0	1 086 000	4 868	493.0	1 164 000	5 217	528.0
1 3/4	44.5	5.67	8.44	266 000	1 192	121.0	306 000	1 372	139.0	1 242 000	5 567	563.0	1 410 000	6 320	640.0
1 7/8	47.6	6.50	9.67	304 000	1 363	138.0	348 000	1 560	158.0	1 586 000	7 109	719.0	1 710 000	7 710	785.0
2	50.8	7.39	11.00	344 000	1 542	156.0	396 000	1 775	180.0	1 845 000	8 260	840.0	2 000 000	9 070	925.0
2 1/8	54.0	8.35	12.43	384 000	1 721	174.0	442 000	1 981	200.0	2 187 000	9 570	977.0	2 480 000	10 700	1 097.0
2 1/4	57.2	9.36	13.93	430 000	1 927	195.0	494 000	2 214	224.0	2 500 000	11 100	1 130.0	2 920 000	12 400	1 260.0
2 3/8	60.3	10.40	15.48	478 000	2 142	217.0	548 000	2 456	249.0	2 840 000	12 600	1 280.0	3 280 000	14 000	1 420.0
2 1/2	63.5	11.60	17.26	524 000	2 349	238.0	604 000	2 707	274.0	3 160 000	14 100	1 430.0	3 640 000	15 500	1 570.0
2 5/8	66.7	12.80	19.05	576 000	2 582	261.0	658 000	2 949	298.0	3 500 000	15 600	1 580.0	4 060 000	17 000	1 720.0
2 3/4	69.9	14.00	20.83	628 000	2 815	285.0	736 000	3 299	334.0	3 960 000	17 100	1 730.0	4 520 000	18 500	1 870.0
2 7/8	73.0	15.30	22.77	682 000	3 057	309.0	796 000	3 568	361.0	4 320 000	18 600	1 880.0	5 080 000	20 000	2 020.0
3	76.2	16.60	24.70	740 000	3 317	336.0	856 000	3 837	388.0	4 800 000	20 100	2 030.0	5 640 000	21 500	2 170.0
3 1/8	79.4	18.00	26.79	798 000	3 577	362.0	920 000	4 124	417.0	5 160 000	21 600	2 180.0	6 020 000	23 000	2 320.0
3 1/4	82.6	19.50	29.02	858 000	3 846	389.0	984 000	4 410	446.0	5 620 000	23 100	2 330.0	6 480 000	24 500	2 470.0
3 3/8	85.7	21.00	31.25	918 000	4 115	416.0	1 074 000	4 814	487.0	6 180 000	24 600	2 480.0	7 040 000	26 000	2 620.0
3 1/2	88.9	22.70	33.78	982 000	4 402	445.0	1 144 000	5 128	519.0	6 640 000	26 100	2 630.0	7 500 000	27 500	2 770.0
3 3/4	95.3	26.00	38.69	1 114 000	4 993	505.0	1 290 000	5 782	585.0	7 400 000	28 600	2 880.0	8 260 000	30 000	3 020.0
4	101.6	29.60	44.05	1 254 000	5 621	569.0	1 466 000	6 571	665.0	8 260 000	32 100	3 230.0	9 120 000	33 500	3 370.0

Note: The strength of galvanized wire rope is 10% less than the figures given in this table.

**API CLASSIFICATION OF BRIGHT (UNCOATED)
OR DRAWN GALVANIZED WIRE ROPE (continued)**
Configurations (API Spec 9A, 24th edition, June 1, 1995)

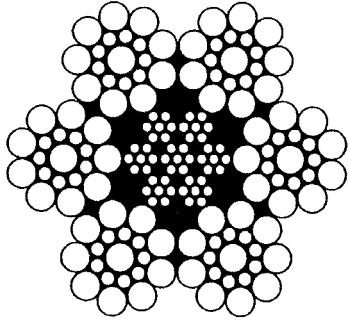

6 x 19 Seale IWRC

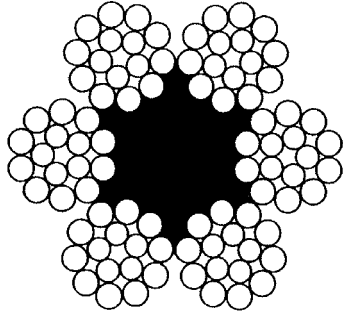

6 x 21 Filler Wire FC

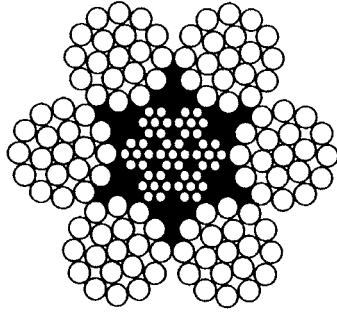

6 x 25 Filler Wire IWRC

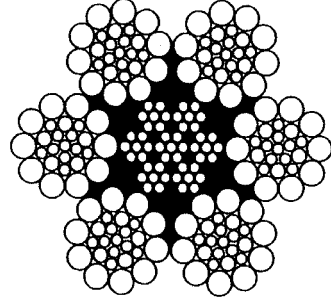

6 x 26 Warrington Seale IWRC

Classification 6 × 19

**API CLASSIFICATION OF BRIGHT (UNCOATED)
OR DRAWN GALVANIZED WIRE ROPE (continued)
Configurations (API Spec 9A, 24th edition, June 1, 1995)**

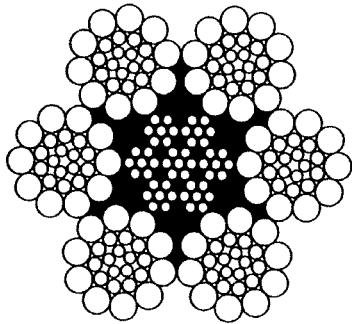

6 x 31 Filler
Wire Seale IWRC

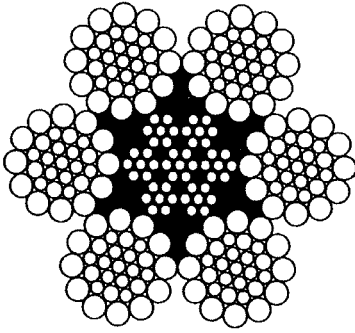

6 x 31
Warrington Seale IWRC

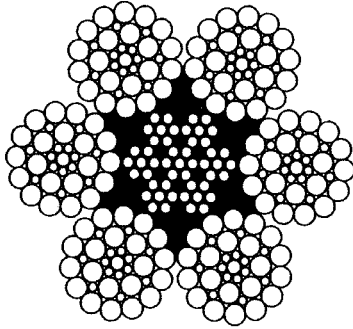

6 x 36 Seale
Filler Wire IWRC

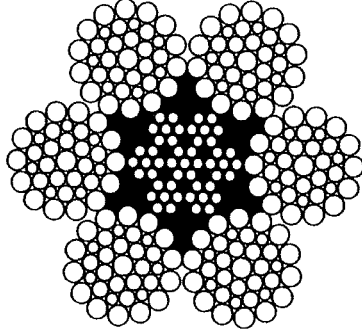

6 x 36
Warrington Seale IWRC

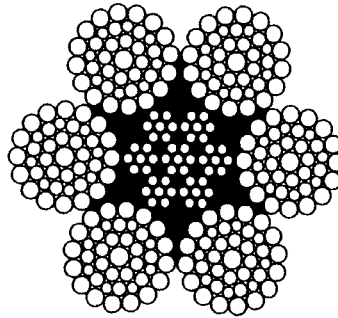

6 x 41
Warrington Seale IWRC

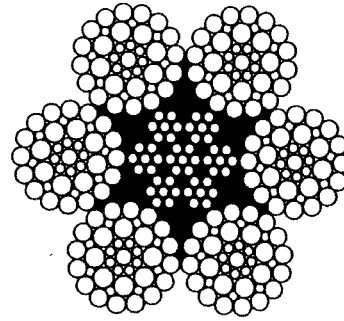

6 x 41 Seale
Filler Wire IWRC

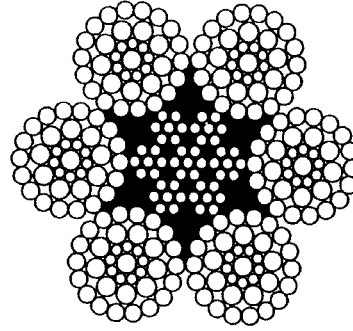

6 x 46 Seale
Filler Wire IWRC

Classification 6 × 37

**API CLASSIFICATION OF BRIGHT (UNCOATED)
OR DRAWN GALVANIZED WIRE ROPE (continued)
Class 6 × 61. Independent Wire Rope Core (IWRC)
(API Spec 9A, 24th edition, June 1, 1995)**

Nominal diameter		Approximate weight			Breaking strength					
					Improved Plow Steel			Extra Improved Plow Steel		
(in)	(mm)	(lb/ft)	(kg/m)	(10 ³ lb)	(kN)	(t)	(10 ³ lb)	(kN)	(t)	
3 1/2	88.9	22.70	33.78	966	4 330	438	1 110	4 975	503	
3 3/4	95.3	26.00	38.69	1 098	4 921	498	1 264	5 666	573	
4	101.6	29.60	44.05	1 240	5 558	562	1 426	6 392	647	
4 1/4	108.0	33.30	49.56	1 388	6 221	630	1 598	7 163	725	
4 1/2	114.3	37.40	55.66	1 544	6 921	700	1 776	7 960	806	
4 3/4	120.7	41.70	62.06	1 706	7 647	774	1 962	8 794	890	
5	127.0	46.20	68.75	1 874	8 400	850	2 156	9 664	978	

Note: The strength of galvanized wire rope is 10% less than the figures given in this table.

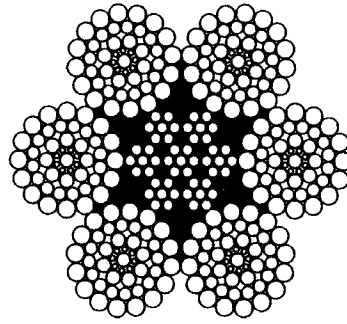

6 x 57
Seale Filler Wire IWRC

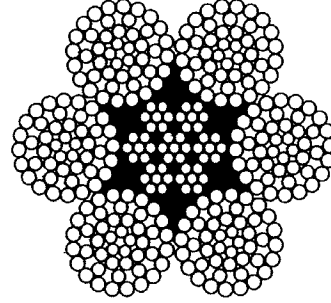

6 x 61
Filler Wire Warrington Seale IWRC

Classification 6 × 61

**API CLASSIFICATION OF BRIGHT (UNCOATED)
OR DRAWN GALVANIZED WIRE ROPE (continued)
Class 6 × 91. Independent Wire Rope Core (IWRC)
(API Spec 9A, 24th edition, June 1, 1995)**

Nominal diameter		Approximate weight		Breaking strength					
				Improved Plow Steel			Extra Improved Plow Steel		
(in)	(mm)	(lb/ft)	(kg/m)	(10 ³ lb)	(kN)	(t)	(10 ³ lb)	(kN)	(t)
4	101.6	29.6	44.0	1 178	5 280	534	1 354	6 069	614
4 1/4	108.0	33.3	49.6	1 320	5 917	599	1 518	6 804	689
4 1/2	114.3	37.4	55.7	1 468	6 580	666	1 688	7 566	766
4 3/4	120.7	41.7	62.1	1 620	7 261	735	1 864	8 365	846
5	127.0	46.2	68.8	1 782	7 987	808	2 048	9 180	929
5 1/4	133.4	49.8	74.1	1 948	8 731	884	2 240	10 040	1 016
5 1/2	139.7	54.5	81.1	2 120	9 502	962	2 438	10 928	1 106
5 3/4	146.1	59.6	88.7	2 296	10 291	1 041	2 640	11 833	1 198
6	152.4	65.0	96.7	2 480	11 116	1 125	2 852	12 783	1 294

Note: The strength of galvanized wire rope is 10% less than the figures given in this table.

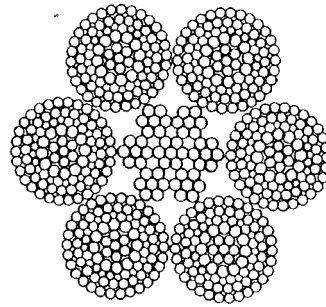

6 x 91
independent wire-rope core

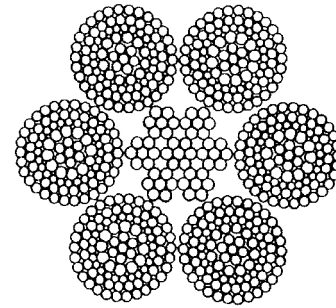

6 x 103
independent wire-rope core

Classification 6 × 91

**API CLASSIFICATION OF BRIGHT (UNCOATED)
OR DRAWN GALVANIZED WIRE ROPE (continued)
Class 8 × 19. Independent Wire Rope Core (IWRC)
(API Spec 9A, 24th edition, June 1, 1995)**

Nominal diameter		Approximate weight				Breaking strength						
		Improved Plow Steel		Extra Improved Plow Steel		Improved Plow Steel		Extra Improved Plow Steel		Improved Plow Steel		Extra Improved Plow Steel
(in)	(mm)	(lb/ft)	(kg/m)	(lb)	(kN)	(t)	(lb)	(kN)	(t)	(lb)	(kN)	(t)
1/2	12.7	0.47	0.70	20 200	91	9.2	23 400	105	10.6	29 400	132	13.3
9/16	14.3	0.60	0.89	25 600	115	11.6	31 400	162	16.4	45 000	202	20.4
5/8	15.9	0.73	1.09	31 400	141	14.2	61 000	273	27.7	79 200	355	35.9
3/4	19.1	1.06	1.58	45 000	202	20.4	99 600	446	45.2	114 600	514	52.0
7/8	22.2	1.44	2.14	61 000	273	27.7						
1	25.4	1.88	2.80	79 200	355	35.9						
1 1/8	28.6	2.39	3.56	99 600	446	45.2						

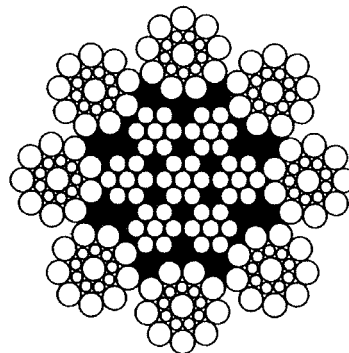

8 x 19
Seale IWRC

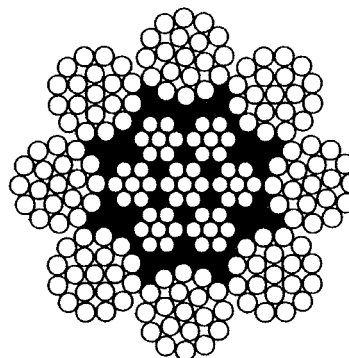

8 x 25
Filler Wire IWRC

Classification 8 × 19

API CLASSIFICATION OF BRIGHT (UNCOATED) OR DRAWN GALVANIZED WIRE ROPE (continued)

Class 18 x 7. Fiber Core (FC)
(API Spec 9A, 24th edition, June 1, 1995)

Nominal diameter		Approximate weight		Breaking strength						
		(in)	(mm)	(lb/ft)	(kg/m)	Improved Plow Steel			Extra Improved Plow Steel	
					(lb)	(kN)	(t)	(lb)	(kN)	(t)
1/2	12.7	0.43	0.64	19 700	88	8.9	21 600	97	9.8	
9/16	14.3	0.55	0.82	24 800	111	11.2	27 200	122	12.3	
5/8	15.9	0.68	1.01	30 600	137	13.9	33 600	151	15.2	
3/4	19.1	0.97	1.44	43 600	195	19.8	48 000	215	21.8	
7/8	22.2	1.32	1.96	59 000	264	26.8	65 000	291	29.5	
1	25.4	1.73	2.57	76 600	343	34.7	84 400	378	38.3	
1 1/8	28.6	2.19	3.26	96 400	432	43.7	106 200	476	48.2	
1 1/4	31.8	2.70	4.02	118 400	531	53.7	130 200	584	59.1	
1 3/8	34.9	3.27	4.87	142 600	639	64.7	156 800	703	71.1	
1 1/2	38.1	3.89	5.79	168 800	757	76.6	185 600	832	84.2	

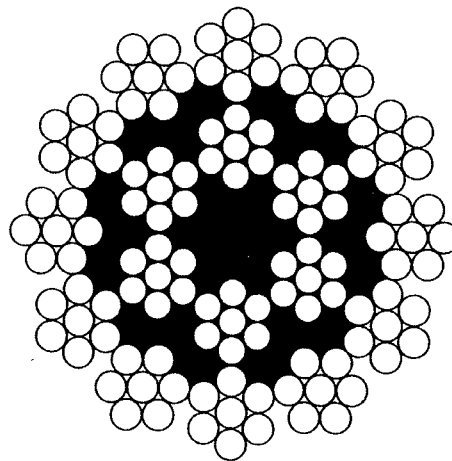

18 x 7 Fiber Core

**API CLASSIFICATION OF BRIGHT (UNCOATED)
OR DRAWN GALVANIZED WIRE ROPE (continued)**

**Class 19 × 7. Metal Core
(API Spec 9A, 24th edition, June 1, 1995)**

Nominal diameter		Approximate weight				Breaking strength						
		Improved Plow Steel		Extra Improved Plow Steel		Improved Plow Steel		Extra Improved Plow Steel		Improved Plow Steel		Extra Improved Plow Steel
(in)	(mm)	(lb/ft)	(kg/m)	(lb)	(kN)	(t)	(lb)	(kN)	(t)	(lb)	(kN)	(t)
1/2	12.7	0.45	0.67	19 700	88	8.9	21 600	97	9.8	27 200	122	12.3
9/16	14.3	0.58	0.86	24 800	111	11.2	27 200	122	12.3	33 600	151	15.2
5/8	15.9	0.71	1.06	30 600	137	13.9	33 600	151	15.2	48 000	215	21.8
3/4	19.1	1.02	1.52	43 600	195	19.8	48 000	215	21.8	65 000	291	29.5
7/8	22.2	1.39	2.07	59 000	264	26.8	65 000	291	29.5	84 400	378	38.3
1	25.4	1.82	2.71	76 600	343	34.7	84 400	378	38.3	106 200	476	48.2
1 1/8	28.6	2.30	3.42	96 400	432	43.7	106 200	476	48.2	130 200	584	59.1
1 1/4	31.8	2.84	4.23	118 400	531	53.7	130 200	584	59.1	156 800	703	71.1
1 3/8	34.9	3.43	5.10	142 600	639	64.7	156 800	703	71.1	185 600	832	84.2
1 1/2	38.1	4.08	6.07	168 800	757	76.6	185 600	832	84.2			

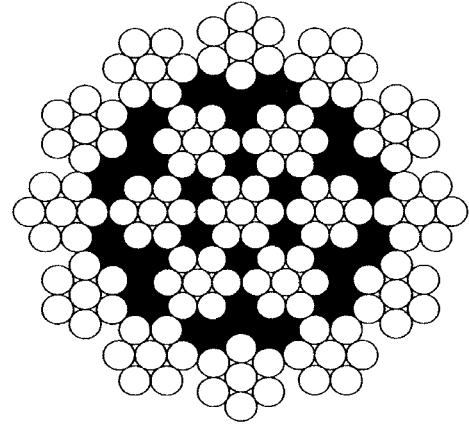

19 × 7

API CLASSIFICATION OF BRIGHT (UNCOATED) OR DRAWN GALVANIZED WIRE ROPE (continued)
Classes 6 × 25 "B", 6 × 27 "H", 6 × 30 "G" and 6 × 31 "V"
(API Spec 9A, 24th edition, June 1, 1995)

Nominal diameter		Approximate weight		Typical nominal strength*					
				Improved Plow Steel		Extra Improved Plow Steel			
(in)	(mm)	(lb/ft)	(kg/m)	(lb)	(kN)	(t ²)	(lb)	(kN)	(t ³)
1/2	13.0	0.47	0.70	25 400	113	11.5	28 000	125	12.7
9/16	14.3	0.60	0.89	32 000	142	14.5	35 200	157	16.0
5/8	16.0	0.74	1.10	39 400	175	17.9	43 400	193	19.7
3/4	19.0	1.06	1.58	56 400	251	25.6	62 000	276	28.1
7/8	22.0	1.46	2.17	76 000	330	34.5	83 800	373	38.0
1	25.0	1.89	2.81	98 800	439	44.8	108 800	484	49.3
1 1/8	29.0	2.39	3.56	124 400	553	56.4	137 000	609	62.1
1 1/4	32.0	2.95	4.39	152 600	679	69.2	168 000	747	76.2
1 3/8	35.0	3.57	5.31	183 600	817	83.3	202 000	898	91.6
1 1/2	38.0	4.25	6.32	216 000	961	98.0	238 000	1 060	108.0
1 5/8	41.0	4.99	7.43	254 000	1 130	115.0	280 000	1 250	127.0
1 3/4	44.0	5.74	8.54	292 000	1 300	132.0	322 000	1 430	146.0
1 7/8	48.0	6.65	9.90	334 000	1 490	151.0	368 000	1 640	167.0
2	51.0	7.56	11.25	378 000	1 680	172.0	414 000	1 840	188.0

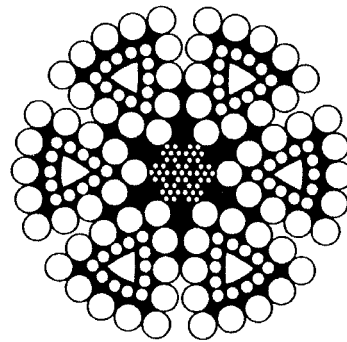

6 x 25 Style B
Flattened Strand IWRC

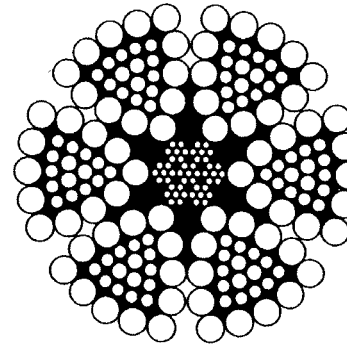

6 x 27 Style H
Flattened Strand IWRC

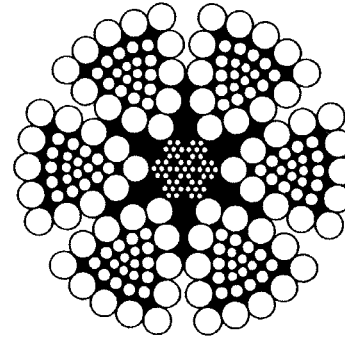

6 x 30 Style G
Flattened Strand IWRC

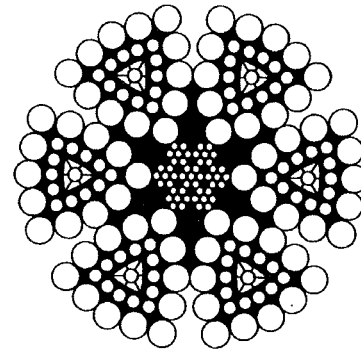

6 x 31 Style V
Flattened Strand IWRC

Flattened strand constructions

API WIRE ROPE Sheave sizes (API RP 9B, May 30, 1986)

I WINCH DRUM

The winch drum must allow wire rope spooling with a minimum of layering. Its diameter must be more than twenty times the nominal rope diameter.

II SHEAVES

$$D_T = dF$$

D_T = sheave groove root diameter

d = nominal rope diameter

F = service factor

Rope type	Service factor F	
	Conditions	
	A	B
6 × 17	72	42
6 × 17 S	56	33
6 × 19 S	51	30
6 × 21 F	45	26
6 × 25 FW	41	24
6 × 31	38	22
6 × 37	33	18
8 × 19 S	36	21
8 × 19 W	31	18
18 × 7 and 19 × 7	51	36
FS	51	45

Condition A: ideal size.

Condition B: less rigorous size but implying shorter rope life.

Example: with a 6 × 19 wire rope, diameter 1 1/4 inches, in condition A:

$$D_T = 1.25 \times 51 = 63.75 \text{ in}$$

$$= 1620 \text{ mm}$$

In condition B: $D_T = 953 \text{ mm}$
 $= 37.50 \text{ in}$

SHEAVE GROOVES (API Spec 8A, 12th edition, June 1, 1992)

Nominal wire rope diameter (in)	New groove root radius: R		Worn groove gage radius: R	
	(in)	(mm)	(in)	(mm)
1/4	0.137	3.48	0.129	3.28
5/16	0.167	4.24	0.160	4.06
3/8	0.201	5.11	0.190	4.83
7/16	0.234	5.94	0.220	5.59
1/2	0.271	6.88	0.256	6.50
9/16	0.303	7.70	0.288	7.32
5/8	0.334	8.48	0.320	8.13
3/4	0.401	10.19	0.380	9.65
7/8	0.468	11.89	0.440	11.18
1	0.543	13.79	0.513	13.03
1 1/8	0.605	15.37	0.577	14.66
1 1/4	0.669	16.99	0.639	16.23
1 3/8	0.736	18.69	0.699	17.75
1 1/2	0.803	20.40	0.759	19.28
1 5/8	0.876	22.25	0.833	21.16
1 3/4	0.939	23.85	0.897	22.78
1 7/8	1.003	25.48	0.959	24.36
2	1.070	27.18	1.019	25.88
2 1/8	1.137	28.88	1.079	27.41
2 1/4	1.210	30.73	1.153	29.29
2 3/8	1.273	32.33	1.217	30.91
2 1/2	1.338	33.99	1.279	32.49
2 5/8	1.404	35.66	1.339	34.01
2 3/4	1.481	37.62	1.409	35.79
2 7/8	1.544	39.22	1.473	37.41
3	1.607	40.82	1.538	39.07

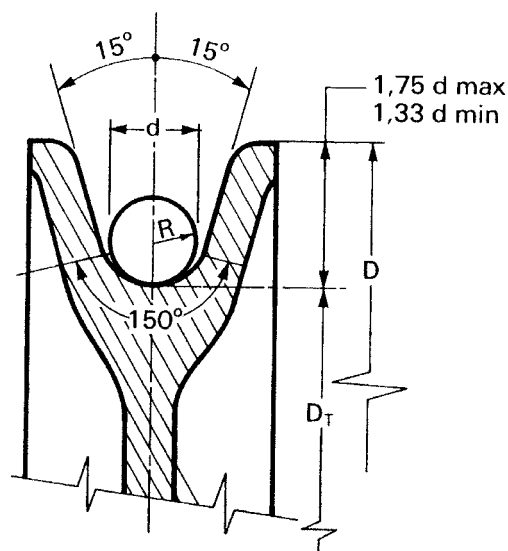

Drilling line and casing line sheave

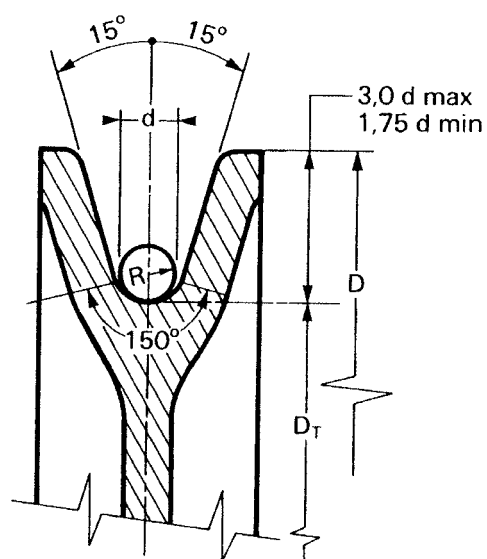

Sand line sheave

WORK DONE BY A DRILLING LINE

I ROUND-TRIP OPERATIONS

Running the drill string into the hole and pulling the string out of the hole (to change the bit) at depth L :

$$T_m = 0.981 \left[\rho L (L + \ell) + 4L \left(P + \frac{d}{2} \right) \right] 10^{-6}$$

where :

T_m = amount of work (10^3 daN.km)

L = depth of hole (m)

ℓ = length of a stand (m) (single, double or triple) (m)

d = additional weight due to drill collars and bit (accounting for buoyancy) (kg) (see Note)

ρ = weight per meter of drill pipes with tool-joints (accounting for buoyancy) (kg/m)

P = total weight of travelling block/elevator assembly (kg)

II DRILLING OPERATIONS

To drill to depth L_1 :

$$T_f = 3 T_{m1}$$

To drill from depth L_1 to depth L_2 :

$$T_{f1-2} = 3 [T_{m2} - T_{m1}]$$

III CORING OPERATION

Between depth L_1 and depth L_2 :

$$T_{c1-2} = 2 [T_{m2} - T_{m1}]$$

Example:

Depth = 400 m; 100 m of DC 8" × 3"; DP 5" – 19.5 (TJ 6 1/4)-E.

Mud $d = 1.4$; weight of travelling block/elevator assembly $P = 8000$ kg.

Weight of drill pipes in air = 31.06 kg/m.

Apparent weight = $31.06 \times 0.822 = 25.53$ kg/m.

Weight of DC in air = 218.8 kg/m.

Weight of DC in mud = 179.85 kg/m.

Total additional apparent weight $d = (179.85 - 25.53) \times 100 = 15\,432$ kg.

$$T_m = 0.981 \left[25.53 \times 400(400 + 27) + 4 \times 400 \left(8000 + \frac{15\,432}{2} \right) \right] 10^{-6}$$

$$T_m = 28.9 \cdot 10^3 \text{ daN.km}$$

Note: If L_{DC} is the length of the drill collars

ρ_{DC} is the weight per meter of the drill collars accounting for buoyancy:

$$d = L_{DC} (\rho_{DC} - \rho)$$

CUTOFF PRACTICE FOR DRILLING LINES

Cutoff length as a function of derrick or mast height and drum diameter

(API RP 9B, 9th edition, May 30, 1986)

Derrick or mast height (ft)	Drum diameter (in)													
	11	13	14	16	18	20	22	24	26	28	30	32	34	36
	Cutoff length in meters and number of drum laps													
151 or more										34.6 15.5	34.7 14.5	34.5 13.5	33.9 12.5	33.0 11.5
142 to 150							25.9 13.5	25.9 12.5	25.7 11.5	27.5 11.5	26.8 10.5			
133 to 140						24.7 15.5	25.5 14.5	23.9 12.5	25.7 11.5	25.1 10.5	24.3 9.5			
120 to 132				22.3 17.5	22.3 15.5	23.1 14.5	21.9 12.5	23.9 12.5	23.9 11.5	22.7 9.5	24.3 9.5			
91 to 119		20.2 19.5	19.6 17.5	18.5 14.5	18.0 12.5	18.4 11.5	18.4 10.5	18.2 9.5	19.7 9.5					
73 to 90		18.2 17.5	16.2 14.5	16.0 12.5	16.5 11.5									
Up to 72	11.0 12.5	12.0 11.5												

Note: The cutoff length given is a whole number of drum laps plus one half-lap in order to change the rope crossover point, which is a point of high wear.
m x 3.28 = ft

CUTOFF PRACTICE FOR DRILLING LINES (1) (continued)

Cumulative work before first cutoff (API RP 9B, 9th edition, May 30, 1986)

Derrick or mast height (ft)	Drilling difficulties	Total work of drilling line before first cutoff, function of line diameter									
		1"		1 1/8"		1 1/4"		1 3/8"		1 1/2"	
		10 ³ daN.km	ton. mile	10 ³ daN.km	ton. mile	10 ³ daN.km	ton. mile	10 ³ daN.km	ton. mile	10 ³ daN.km	ton. mile
80 to 87	Very hard	716	500								
	Hard	716	500								
	Medium	716	500								
	Low	859	600								
94 to 100	Very hard	716	500	859	600						
	Hard	716	500	1003	700						
	Medium	716	500	1146	800						
	Low	859	600	1289	900						
126 to 131	Very hard			859	600	1432	1000				
	Hard			1003	700	1575	1100				
	Medium			1146	800	1719	1200				
	Low			1289	900	1862	1300				
133 to 138	Very hard			859	600	1432	1000				
	Hard			1003	700	1575	1100				
	Medium			1146	800	1719	1200				
	Low			1289	900	1862	1300				
142 to 147	Very hard					1432	1000	2292	1600		
	Hard					1575	1100	2578	1800		
	Medium					1719	1200	2864	2000		
	Low					1862	1300	3008	2100		
187 to 189	Very hard							2292	1600	2864	2000
	Hard							2578	1800	3150	2200
	Medium							2864	2000	3437	2400
	Low							3008	2100	3724	2600

(1) This table approximately gives the work done by the drilling line before the first cutoff, for Improved Plow Steel drilling lines with a metal core, using a factor of safety of 5. If a different factor of safety is selected, the curve opposite gives the correction factor to apply to the work given in the table above.

Example:

Mast height = 138 ft

Wire rope diameter = 1 1/4"

Drilling difficulties = hard

Drum diameter = 28 in

Factor of safety = 3

For a factor of 5, the above table gives 1575 10³ daN.km

Factor selected = 3. The curve opposite gives a correction factor of 0.58

Work = 1575 × 0.58 = 914 10³ daN.km before the first cutoff

The table F 23 *Cutoff length as a function of drum diameter* gives 25.70 m for 28 in.

Note: For the following cutoffs, the total work given in the table must be reduced by 100 ton.mile (143 10³ daN.km) for 1 1/8 in in and smaller wire rope diameter, and by 200 ton.mile (286 10³ daN.km) for other wire rope diameters.

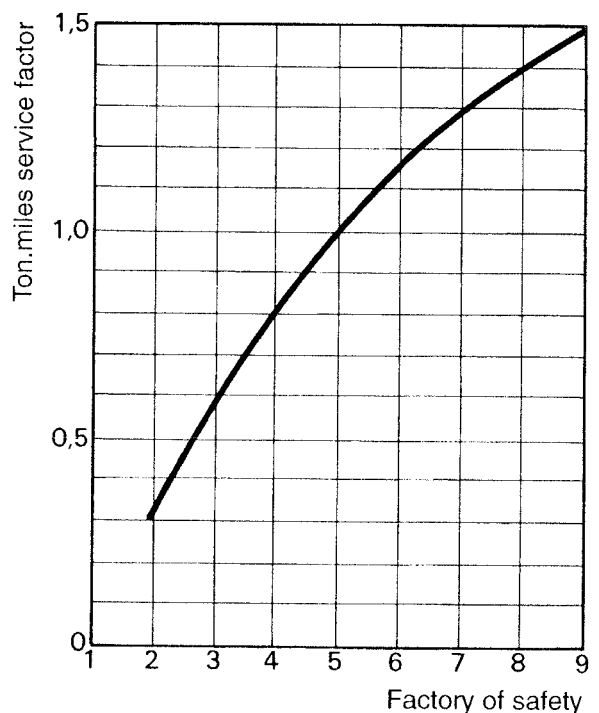

DRUM AND REEL CAPACITY (from IADC Drilling Manual)

- The length of wire rope (in meters) that can be spooled on a drum or reel is:

$$(A + D) \times A \times B \times K$$

where:

- D = diameter of drum barrel (cm)
 - H = diameter of drum flanges (cm)
 - K = factor depending on the wire rope diameter selected
 - B = distance between flanges (cm)
- $$A = \frac{H - D}{2} \text{ (cm)}$$

- The length of wire rope, in meters, contained on an incompletely filled drum or reel is given by the same formula where:

$$A = \frac{H - D - 2Y}{2} \quad Y = \text{distance between the last rope lay and the flange edge}$$

Nominal rope diameter (in)	Factor K	Nominal rope diameter (in)	Factor K	Nominal rope diameter (in)	Factor K
3/8	0.02939	13/16	0.00658	1 5/8	0.00165
7/16	0.02214	7/8	0.00573	1 3/4	0.00143
1/2	0.01721	1	0.00445	1 7/8	0.00126
9/16	0.01378	1 1/8	0.00355	2	0.00111
5/8	0.01129	1 1/4	0.00283	2 1/8	0.00099
11/16	0.00941	1 3/8	0.00236	2 1/4	0.00089
3/4	0.00796	1 1/2	0.00199	2 3/8	0.00078

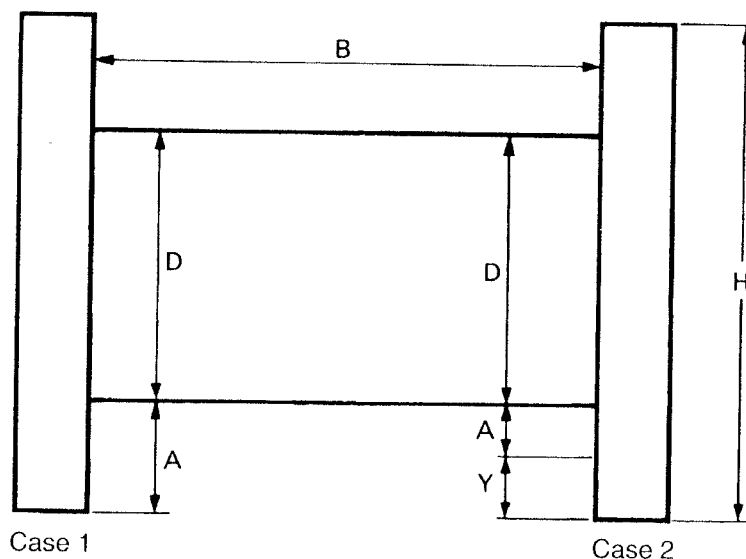

ELEVATOR LINK ARMS

Remaining capacities of worn link arms

Dimensions and nominal capacity of link arms (per set)

		1 3/4 – 150 tons			2 1/4 – 250 tons			2 3/4 – 350 tons			3 1/2 – 500 tons					
Dimension A	(in)	3 1/2	3 3/8	3 1/4	3 1/8	5	4 3/4	4 1/2	5	4 3/4	4 5/8	4 1/2	6	5 5/8	5 1/4	5 3/16
	(mm)	88.9	85.7	82.6	79.4	127.0	120.7	117.5	114.3	127.0	120.7	117.5	114.3	152.4	142.9	133.4
Dimension B	(in)	1 3/4	1 5/8	1 1/2	1 1/2	2 1/4	2 1/8	2 1/16	2	2 3/4	2 1/2	2 7/16	3 1/2	3 1/4	3	2 7/8
	(mm)	44.5	41.3	39.7	38.1	57.2	54.0	52.4	50.8	69.9	66.7	63.5	88.9	82.6	76.2	73.0
Capacity per set	(ton)	150	125	110	100	250	210	188	175	350	290	262	500	440	375	345
	10 ³ daN	135	112	98	89	222	185	168	155	312	258	234	445	392	334	308

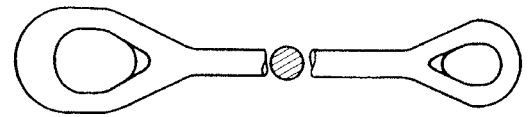

Thickness of wear point in Upper eye dimension " A "

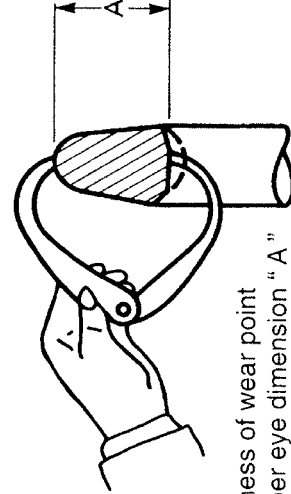

Thickness of wear point in lower eye dimension " B "



Note: The nominal size of elevator link arms is the thickness at point B.
Capacity of set is that of weakest eye.

RECOMMENDED HOISTING TOOL CONTACT SURFACE RADII (API Spec 8A, 12th edition, June 1, 1992)

Capacity		Travelling block and hook bail							
		A ₁ max.		A ₂ min.		B ₁ min.		B ₂ max.	
(short tons)	(10 ³ daN)	(in)	(mm)	(in)	(mm)	(in)	(mm)	(in)	(mm)
25-40	22-36	2 3/4	69.9	2 3/4	69.9	3 1/4	82.6	3	76.2
41-65	36-57	2 3/4	69.9	2 3/4	69.9	3 1/4	82.6	3	76.2
66-100	57-89	2 3/4	69.9	2 3/4	69.9	3 1/4	82.6	3	76.2
101-150	89-133	2 3/4	69.9	2 3/4	69.9	3 1/4	82.6	3	76.2
151-250	133-222	4	101.6	4	101.6	3 1/4	82.6	3	76.2
251-350	222-312	4	101.6	4	101.6	3 1/4	82.6	3	76.2
351-500	312-445	4	101.6	4	101.6	3 1/2	88.9	3 1/4	82.6
501-650	445-578	4	101.6	4	101.6	3 1/2	88.9	3 1/4	82.6
651-750	578-667	6	152.4	6	152.4	3 1/2	88.9	3 1/4	82.6
751-1000	667-890	6	152.4	6	152.4	6 1/4	158.8	6	152.4

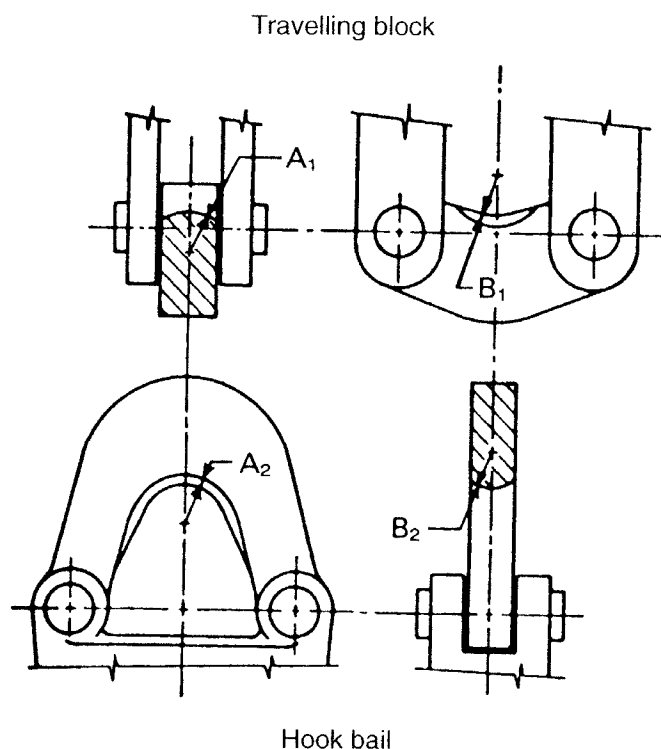

**RECOMMENDED HOISTING TOOL
CONTACT SURFACE RADII (continued)
(API Spec 8A, 12th edition, June 1, 1992)**

Capacity		Elevator link and hook link ear							
		C ₁ max.		C ₂ min.		D ₁ min.		D ₂ max.	
(short tons)	(10 ³ daN)	(in)	(mm)	(in)	(mm)	(in)	(mm)	(in)	(mm)
25-40	22-36	1 1/2	38.1	1 1/2	38.1	1 1/4	31.7	7/8	22.2
41-65	36-57	2 1/2	63.5	2 1/2	63.5	1 1/4	31.7	7/8	22.2
66-100	57-89	2 1/2	63.5	2 1/2	63.5	1 1/2	38.1	1 1/2	28.6
101-150	89-133	2 1/2	63.5	2 1/2	63.5	1 1/2	38.1	1 1/2	28.6
151-250	133-222	4	101.6	4	101.6	1 3/8	44.4	1 3/8	34.9
251-350	222-312	4	101.6	4	101.6	1 3/4	44.4	1 3/8	34.9
351-500	312-445	4	101.6	4 3/4	120.6	2 1/4	57.1	1 7/8	47.6
501-650	445-578	4	101.6	4 3/4	120.6	2 1/4	57.1	1 7/8	47.6
651-750	578-667	4	101.5	5	127.0	2 1/2	63.5	2 1/2	63.5
751-1000	667-890	4 1/2	114.3	5	127.0	3	76.2	2 3/4	69.9

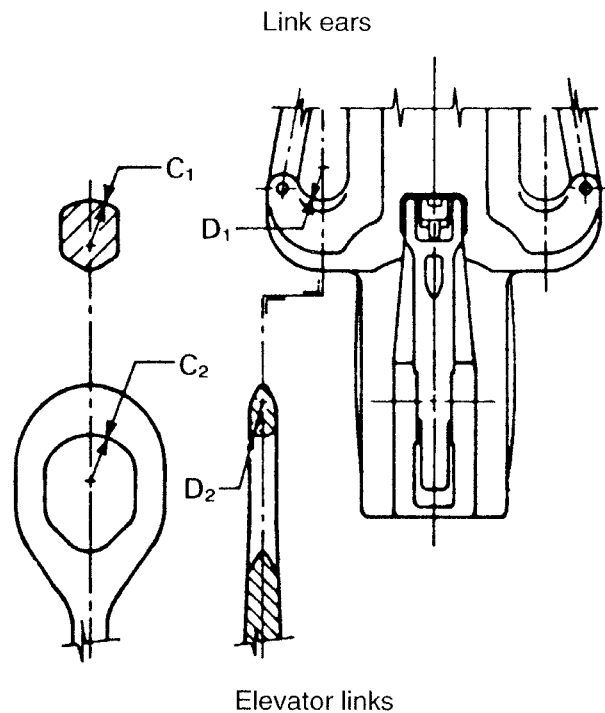

**RECOMMENDED HOISTING TOOL
CONTACT SURFACE RADII (continued)
(API Spec 8A, 12th edition, June 1, 1992)**

Capacity		Hook and swivel bail							
		E ₁ max.		E ₂ min.		F ₁ min.		F ₂ max.	
(short tons)	(10 ³ daN)	(in)	(mm)	(in)	(mm)	(in)	(mm)	(in)	(mm)
25-40	22-36	2	50.8	1 1/2	38.1	3	76.2	3	76.2
41-65	36-57	2	50.8	1 3/4	44.5	3 1/2	88.9	3 1/2	88.9
66-100	57-89	2 1/4	57.2	2	50.8	4	101.6	4	101.6
101-150	89-133	2 1/2	63.5	2 1/4	57.2	4 1/2	114.3	4 1/2	114.3
151-250	133-222	2 3/4	69.9	2 1/2	63.5	4 1/2	114.3	4 1/2	114.3
251-350	222-312	3	76.2	2 3/4	69.9	4 1/2	114.3	4 1/2	114.3
351-500	312-445	3 1/2	88.9	3 1/4	82.6	4 1/2	114.3	4 1/2	114.3
501-650	445-578	3 1/2	88.9	3 1/4	82.6	4 1/2	114.3	4 1/2	114.3
651-750	578-667	4 1/4	108.0	4	101.6	4 1/2	114.3	4 1/2	114.3
751-1000	667-890	5 1/4	133.4	5	127.0	5	127.0	5	127.0

Hook

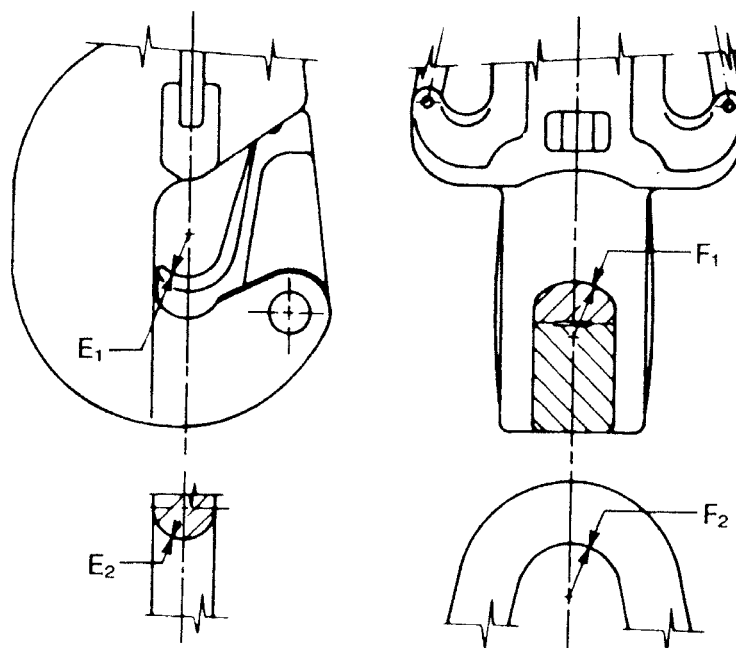

Swivel bail

DRILL PIPE ELEVATOR BORES (API Spec 8A, 12th edition, June 1, 1992)

Tool joint designation reference	Drill pipe size and style (all weights and grades)	Weld-on tool joints										Elev. marking		
		Taper shoulder					Square shoulder							
		Neck diam. max.		Elev. bore		Neck diam. max.		Elev. bore		Neck diam. max.			Elev. bore	
		(in)	(mm)	(in)	(mm)	(in)	(mm)	(in)	(mm)	(in)	(mm)		(in)	(mm)
NC26 (2 3/8 IF)	2 3/8 EU	2 9/16	65.09	2 21/32	67.47	*	*	3 3/16	80.96	3 3/8	*		2 3/8 EU	
NC31 (2 7/8 IF)	2 7/8 EU	3 3/16	80.96	3 9/32	83.34	3 7/8	100.81	3 7/8	98.43	4 1/16	103.19	85.73	2 7/8 EU	
NC38 (3 1/2 IF)	3 1/2 EU	3 7/8	98.43	3 31/32	100.81	3 7/8	100.81	3 7/8	98.43	4 1/16	103.19		3 1/2 EU	
NC40 (4 FH)	3 1/2 EU	3 7/8	98.43	3 31/32	100.81	3 7/8	100.81	3 7/8	98.43	4 1/16	103.19		3 1/2 EU	
NC40 (4 FH)	4 IU	4 3/16	106.36	4 9/32	101.86	4 1/8	104.78	4 1/8	104.78	4 5/16	109.54		4 IU	
NC46 (4 IF)	4 EU	4 1/2	114.30	4 23/32	119.86	4 1/2	114.30	4 1/2	114.30	4 13/16	122.24		4 EU	
4 1/2 FH**	4 1/2 IU	4 11/16	119.06	4 25/32	121.44	4 5/8	117.48	4 5/8	117.48	4 13/16	122.24		4 1/2 IU	
	4 1/2 IEU	4 11/16	119.06	4 25/32	121.44	4 5/8	117.48	4 5/8	117.48	4 13/16	122.24		4 1/2 IEU	
	4 1/2 IU	4 11/16	119.06	4 25/32	121.44	4 5/8	117.48	4 5/8	117.48	4 13/16	122.24		4 1/2 IEU	
	4 1/2 IEU	4 11/16	119.06	4 25/32	121.44	4 5/8	117.48	4 5/8	117.48	4 13/16	122.24		4 1/2 IEU	
NC50 (4 1/2 IF)	4 1/2 EU	5	127.00	5 1/4	133.35	5	127.00	5	127.00	5 5/16	134.94		4 1/2 EU	
5 1/2 FH**	5 IEU	5 1/4	130.18	5 1/4	133.35	5 1/8	130.18	5 1/8	130.18	5 5/16	134.94		5 IEU	
	5 IEU	5 1/8	130.18	5 1/4	133.35	5 1/8	130.18	5 1/8	130.18	5 5/16	134.94		5 IEU	
5 1/2 FH**	5 IEU	5 11/16	144.46	5 13/16	147.64	5 11/16	144.46	5 11/16	144.46	5 7/8	149.23		5 1/2 IEU	
6 5/8 FH	6 5/8 IEU	6 57/64	175.02	7 1/32	178.59								6 5/8	

Note: Elevators with the same bores are the same elevators.

* Not manufactured.

** Obsolescent connection.

BRAKE BLOCKS

6 hole API brake block

API block No.	A (in)	B (in)	C (in)
1	6	1 1/4	3 1/2
2	7	1 1/2	4
3	8	1 3/4	4 1/2
4	9	2	5
5	10	2 1/4	5 1/2
6	11	2 1/2	6
7	12	2 3/4	6

4 hole API brake block

API block No.	D (in)	E (in)	F (in)
10	6	1 1/4	3 1/2
11	7	1 1/2	4
12	8	1 1/2	5
13	9	1 1/2	6
14	10	1 1/2	7

Brake block thickness: brake block thickness is not stipulated; for any given block size, however, several standard thickness are provided:

- 6 hole brake block:

T (in) = 5/8, 3/4, 7/8, 1, 1 1/8, 1 1/4

- 4 hole brake block:

T (in) = 5/8, 3/4, 7/8, 1

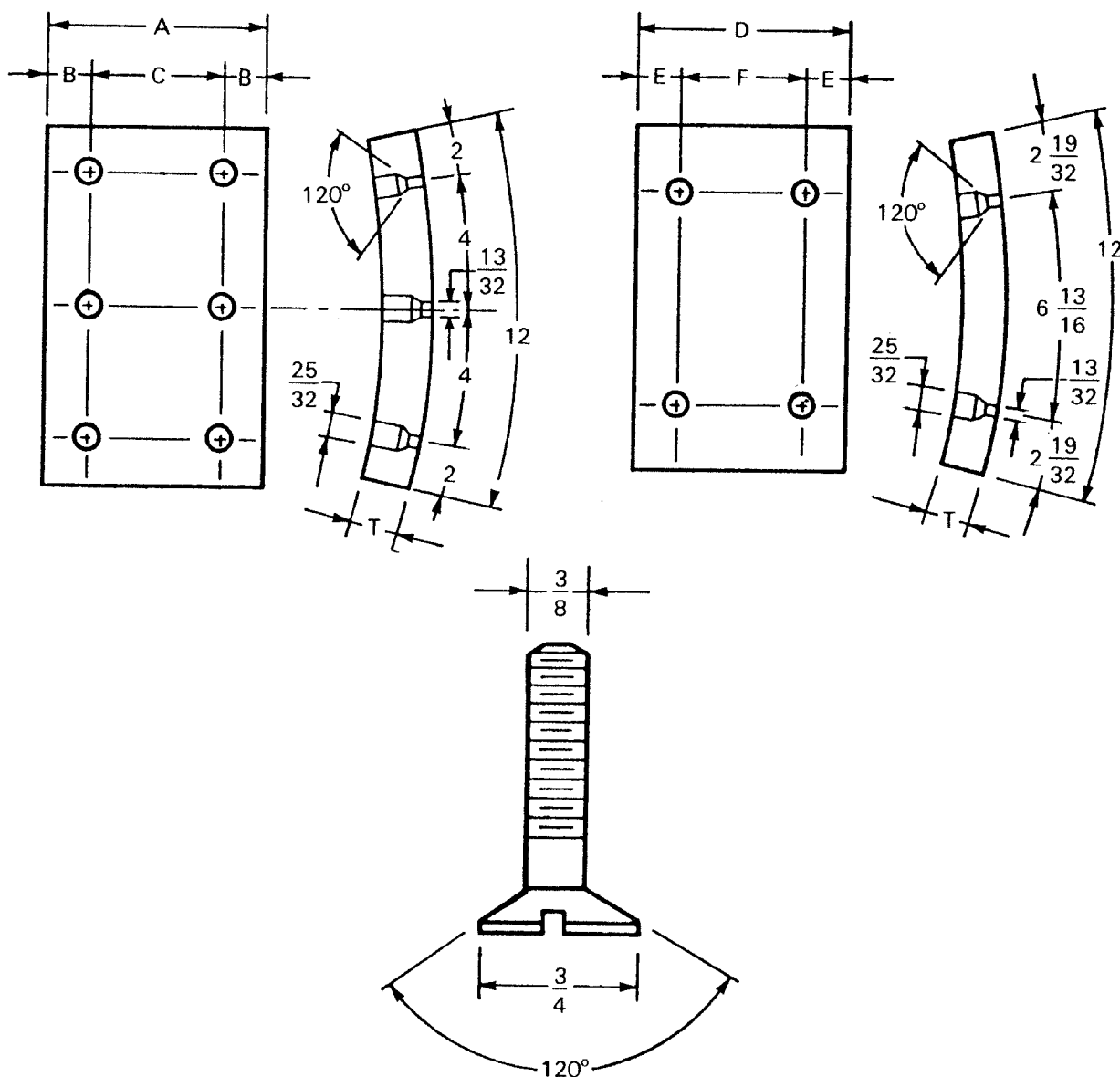

Screws for fastening brake blocks to the brake bands shall be 3/8, 120°, flathead brass machine screw as shown in figure. Screw threads shall be 3/8-16 UNC-2A.

VIBRATOR AND DRILLING HOSE
(API Spec 7K, 2nd edition, February, 1996)

Inside diameter <i>D</i>		Standard length (1) <i>L</i>		Line pipe thread size <i>T</i> (in)	Grade
(in)	(mm)	(ft)	(m)		
2	50.8	35	10.67	2 1/2	A-B
		40	12.19	2 1/2	A-B-C
2 1/2	63.5	10	3.05	3	A-B-C-D-E
		12	3.66	3	A-B-C-D-E
		15	4.57	3	A-B-C-D-E
		20	6.10	3	A-B-C-D-E
		30	9.14	3	A-B-C-D-E
		50	15.24	3	A-B-C-D-E
		55	16.76	3	A-B-C-D-E
		3	76.2	10	3.05
		12	3.66	4	C-D-E
		15	4.57	4	C-D-E
		20	6.10	4	C-D-E
		30	9.14	4	C-D-E
		55	16.76	4	C-D-E
		60	18.29	4	C-D-E
		70	21.34	4	C-D-E
		75	22.86	4	C-D-E
3 1/2	88.9	10	3.05	4	C-D-E
		12	3.66	4	C-D-E
		15	4.57	4	C-D-E
		20	6.10	4	C-D-E
		30	9.14	4	C-D-E
		55	16.76	4	C-D-E
		60	18.29	4	C-D-E
		70	21.34	4	C-D-E
		75	22.86	4	C-D-E
4	101.6	10	3.05	5	C-D
		12	3.66	5	C-D
		15	4.57	5	C-D
		20	6.10	5	C-D
		30	9.14	5	C-D
		55	16.76	5	C-D
		60	18.29	5	C-D
		70	21.34	5	C-D
		75	22.86	5	C-D

(1) Non standard lengths in 5 ft (1.50 m) increments may be marked with API monogram provided the hose meets all other requirements of this specification.

VIBRATOR AND DRILLING HOSE (continued)
(API Spec 7K, 2nd edition, February, 1996)

Grade	Working pressure		Test pressure	
	(psi)	(kPa)	(psi)	(kPa)
Grade A	1 500	10 300	3 000	20 600
Grade B	2 000	13 800	4 000	27 600
Grade C	4 000	27 600	8 000	55 200
Grade D	5 000	34 500	10 000	69 000
Grade E	7 500	51 700	15 000	103 400

Hose length

$$L = \frac{L_r}{2} + \pi R + S$$

with:

L = length of hose in feet or meters

L_r = length of hose travel in feet or meters

R = minimum bending radius of hose in feet or meters:

$R = 0.9$ m (3 ft) for 2" hose

$R = 1.2$ m (4 ft) for 2 1/2 cm and 3" hose

$R = 1.4$ m (4 1/2 ft) for 3 1/2" hose

S = allowance for contraction in L due to maximum recommended working pressure in feet or meters, which is 0.3 m (1 ft) for all sizes of hose

Stand pipe height

$$H_s = \frac{L_r}{2} + Z$$

with:

H_s = vertical height of stand pipe in feet or meters

L_r = length of hose in feet or meters

Z = height, in ft or m, from the top of the derrick floor to the end of hose at swivel when the swivel is in its lowest drilling position

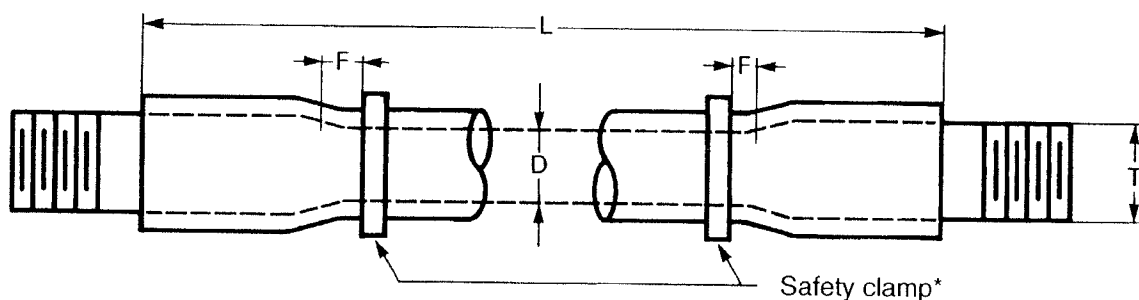

F = For drilling hoses, this dimension must be 6 to 18 inches. For drilling pump hoses, this dimensions is 6 to 10 inches

* Note: Manufacturer must mark the hose: "Fix safety clamp here".

CHAINS

(API Standard 7F, 5th edition, October 1, 1993)

I SINGLE AND MULTIPLE CHAIN ASSEMBLIES

Chains are designated by:

a) A number of which the right-hand digit is:

0 for standard chain

1 for lightweight chain

5 for chain without roller

and the one or two digits to the left represent(s) the pitch of the chain expressed as the number of 1/8 in increments.

b) A number representing the number of chain strands

c) The letter H may be inserted between these two numbers for a heavy chain.

Example: chain 160-6 or 160-H-6

0 = standard

16 = $16/8 = 2$ in

6 = six-strand chain

H = heavy

In the H series, only the flange thickness are different.

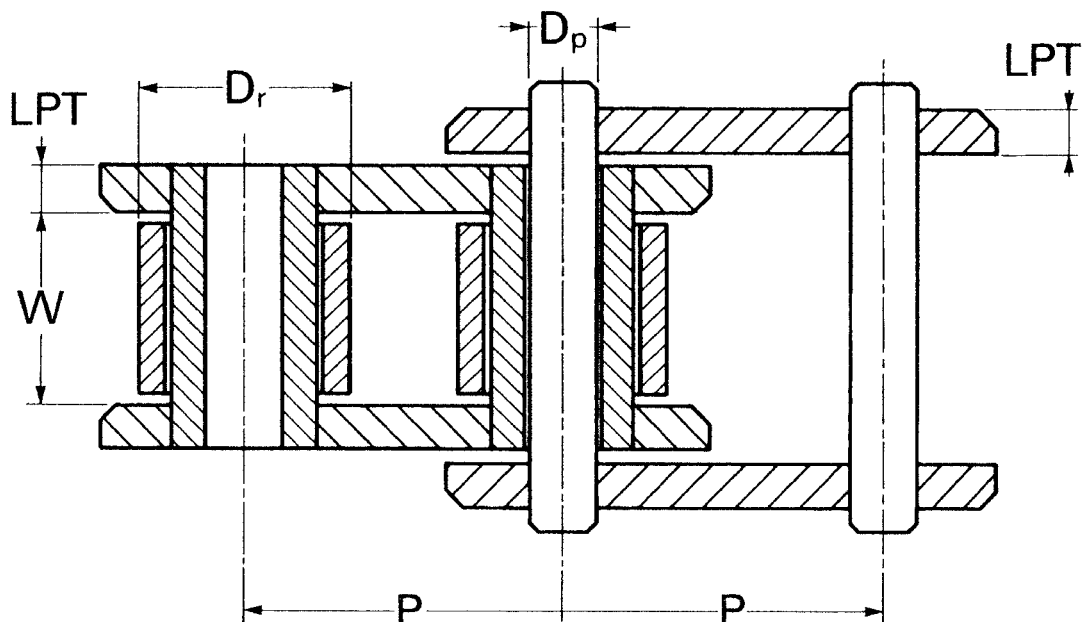

CHAINS (continued) Standard chain dimensions (ANSI Standard, B29.1)

Chain No.	Pitch P		Roller diameter D_r		Inner link width W		Pin diameter D_p		Tension for measuring length		Flange thickness LPT		
	(in)	(mm)	(in)	(mm)	(in)	(mm)	(in)	(mm)	(lb)	(kg)	Standard		
											(in)	(mm)	(in)
*25	1/4	6.4	0.130	3.3	1/8	3.2	0.0905	2.3	18	8.2	0.030	0.8	-
*35	3/8	9.5	0.200	5.1	3/16	4.8	0.1410	3.6	18	8.2	0.050	1.3	-
41	1/2	12.7	0.306	7.8	1/4	6.4	0.1410	3.6	18	8.2	0.050	1.3	-
40	1/2	12.7	0.312	7.9	5/16	7.9	0.1560	4.0	31	14.1	0.060	1.5	-
50	5/8	15.9	0.400	10.2	3/8	9.5	0.2000	5.1	49	22.2	0.080	2.0	-
60	3/4	19.1	0.469	11.9	1/2	12.7	0.2340	5.9	70	31.8	0.094	2.4	-
80	1	25.4	0.625	15.9	5/8	15.9	0.3120	7.9	125	56.7	0.125	3.2	3.2
100	1 1/4	31.8	0.750	19.1	3/4	19.1	0.3750	9.5	195	88.5	0.156	4.0	4.0
120	1 1/2	38.1	0.875	22.2	1	25.4	0.4370	11.1	281	127.5	0.187	4.7	4.7
140	1 3/4	44.5	1.000	25.4	1	25.4	0.5000	12.7	383	173.7	0.219	4.7	5.6
160	2	50.8	1.125	28.6	1 1/4	31.8	0.5620	14.3	500	226.8	0.250	5.6	6.4
180	2 1/4	57.2	1.406	35.7	1 13/32	35.7	0.6870	17.4	633	287.1	0.281	6.4	7.1
200	2 1/2	63.5	1.562	39.7	1 1/2	38.1	0.7810	19.8	781	354.3	0.312	7.1	7.9
240	3	76.2	1.875	47.6	7/8	22.2	0.9370	23.8	1125	510.3	0.375	7.9	9.5
												0.500	12.7

(*) Without roller.

CHAINS (continued)

II ROTARY CHAINS

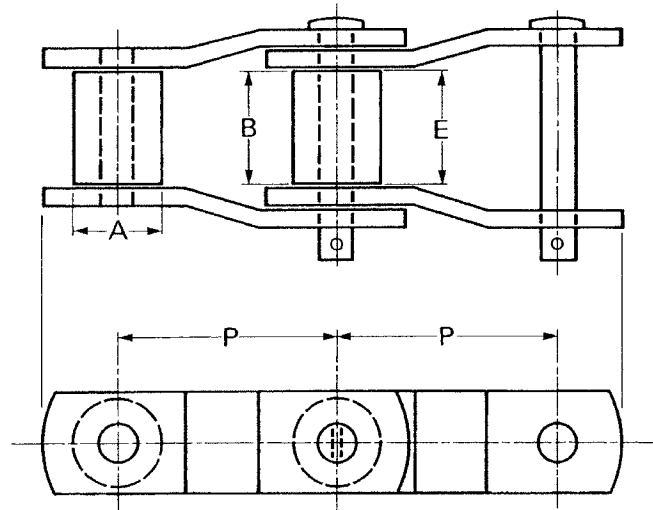

Standard rotary chains are given in the Table below:

	Nominal size (in)					
	3		3 1/8		4	
	(in)	(mm)	(in)	(mm)	(in)	(mm)
Pitch <i>P</i>	3.075	78.1	3.125	79.4	4.063	103.2
Roller diameter <i>A</i>	1 1/4	31.7	1 5/8	41.3	1 3/4	44.4
Roller length <i>B</i>	1 7/16	36.5	1 19/32	40.5	1 7/8	47.6
Distance between flanges <i>E</i>	1 1/2	38.1	1 5/8	41.3	1 15/16	49.2
Distance between center lines for duplex chains	-	-	3 3/16	81.0	-	-
Number of links in 10 ft (3.048 m)	39		39		30	

Note: For the purpose of measuring standard length, the chains should be under a tensile load of 500 lb (225 daN).

III LENGTH OF A CHAIN

$$L = 2C + \frac{N+n}{2} + 39.5 \frac{(N-n)^2}{C}$$

where:

L = chain length in pitches

C = distance between sprocket centres in pitches

N = number of teeth on the large sprocket

n = number of teeth on the small sprocket

IV PROPER CHAIN TENSION

For a check of a chain tension, turn one sprocket to tighten the lower strand of chain; then measure the sag of upper strand. This sag measured at midpoint should be approximately two to three per cent of the length of the tangent to the sprockets.

Example: If the length of the tangent between the sprockets is 200 cm, the sag shall be between 4 and 6 cm.

ROTARY TABLE OPENING AND SQUARE DRIVE MASTER BUSHING (API Spec 8C, 2nd edition, June 1, 1992)

Nominal table size (in)	Rotary-table opening						Square drive master bushing											
	A		B		C		D maximal		A ₁		B ₁		C ₁		D ₁		Concentricity TIR	
	(cm)	(in)	(cm)	(in)	(cm)	(in)	(cm)	(in)	(cm)	(in)	(cm)	(in)	(cm)	(in)	(cm)	(in)	(cm)	(in)
17 1/2	44.45	17 1/2	46.20	18 3/16	13.33	5 1/4	1 3/4	44.29	17 7/16	46.04	18 1/8	13.33	5 1/4	4.445	1 3/4	0.794	1/32	
20 1/2	52.07	20 1/2	53.82	21 3/16	13.33	5 1/4	1 3/4	51.91	20 7/16	53.66	21 1/8	13.33	5 1/4	4.445	1 3/4	0.794	1/32	
27 1/2	69.85	27 1/2	71.60	28 3/16	13.33	5 1/4	1 3/4	69.69	27 7/16	71.28	28 1/16	13.33	5 1/4	4.445	1 3/4	0.794	1/32	
37 1/2	95.25	37 1/2	-	-	-	-	-	95.08	37 7/16	-	-	-	-	-	-	-	-	
49 1/2	125.73	49 1/2	-	-	-	-	-	-	-	-	-	-	-	-	-	-	-	

Note: Pipe slips and master bushing must have a taper of 4 in. per foot on diameter (33.33%), that is an angle of 9°27'45".

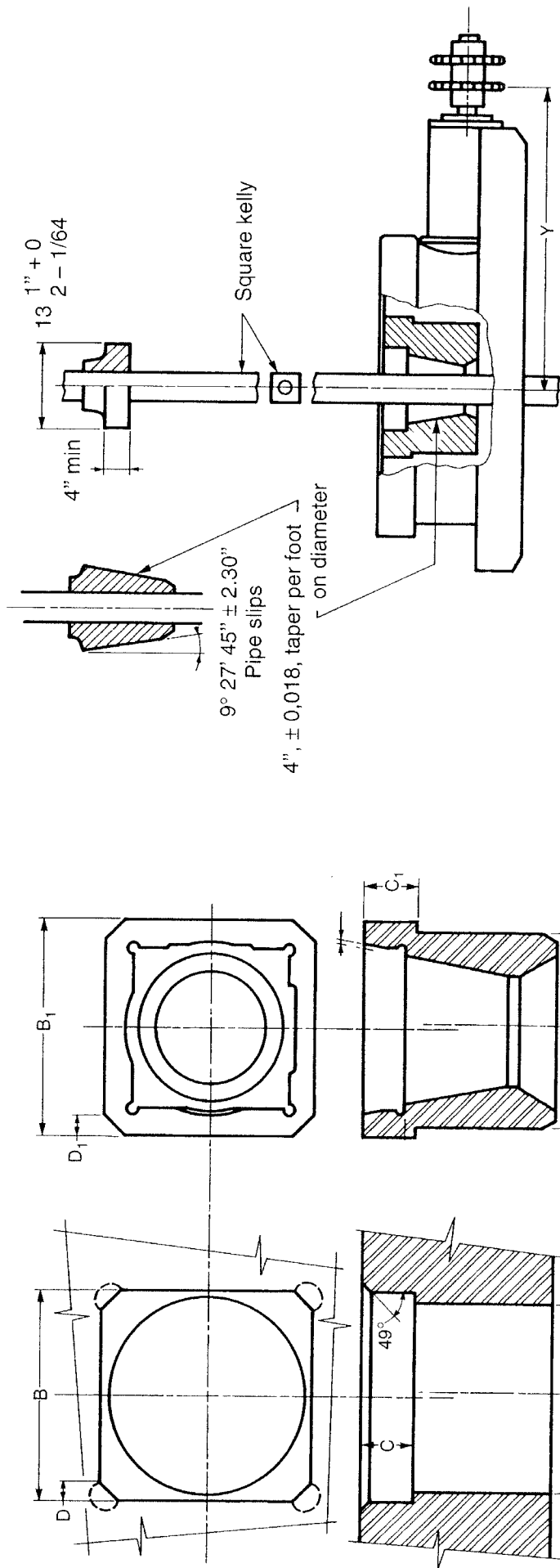

Y: the distance between the center of the rotary table and the axis of the first gear wheel is 53 1/4 inches for openings of more than 20 inches, 44 inches for openings less than 20 inches, and 65 inches for 49 1/2 inch rotary tables.

FOUR-PIN DRIVE KELLY BUSHING AND MASTER BUSHING

(API Spec 8C, 2nd edition, June 1, 1992)

Nominal table size (in)	F		G		H		I		J		K	
	± 1.6 (mm)	± 1/16 (in)	± 0.13 (mm)	± 0.005 (in)	(mm)	(in)	± 0.13 (mm)	± 0.005 (in)	+ 1.6 - 0 (mm)	+ 1/16 - 0 (in)	+ 1/16 - 0 (mm)	+ 1/16 - 0 (in)
17 1/2	482.6	19	65.2	2.565	107.9	4 1/4	62.8	2.472	365.1	14 3/8	257.2	10 1/8
20 1/2	584.2	23	65.2	2.565	107.9	4 1/4	62.8	2.472	365.1	14 3/8	257.2	10 1/8
27 1/2	654.2	25 3/4	86.2	3.395	107.9	4 1/4	82.9	3.265	365.1	14 3/8	257.2	10 1/8
37 1/2	654.1	25 3/4	86.2	3.395	107.9	4 1/4	82.9	3.265	-	-	-	-
49 1/2	-	-	-	-	-	-	-	-	-	-	-	-

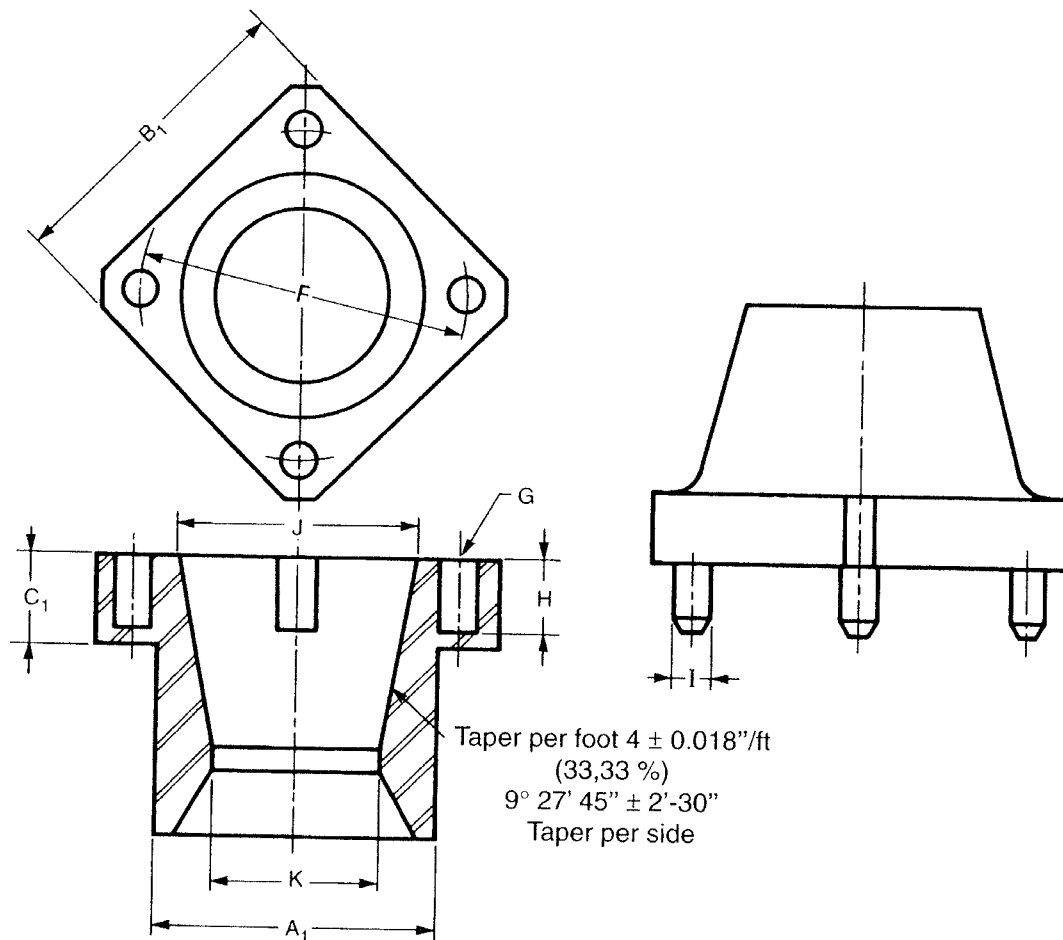

TENSION IN SLINGS

Two-wire slings

I PRINCIPLE OF BREAKDOWN OF FORCES

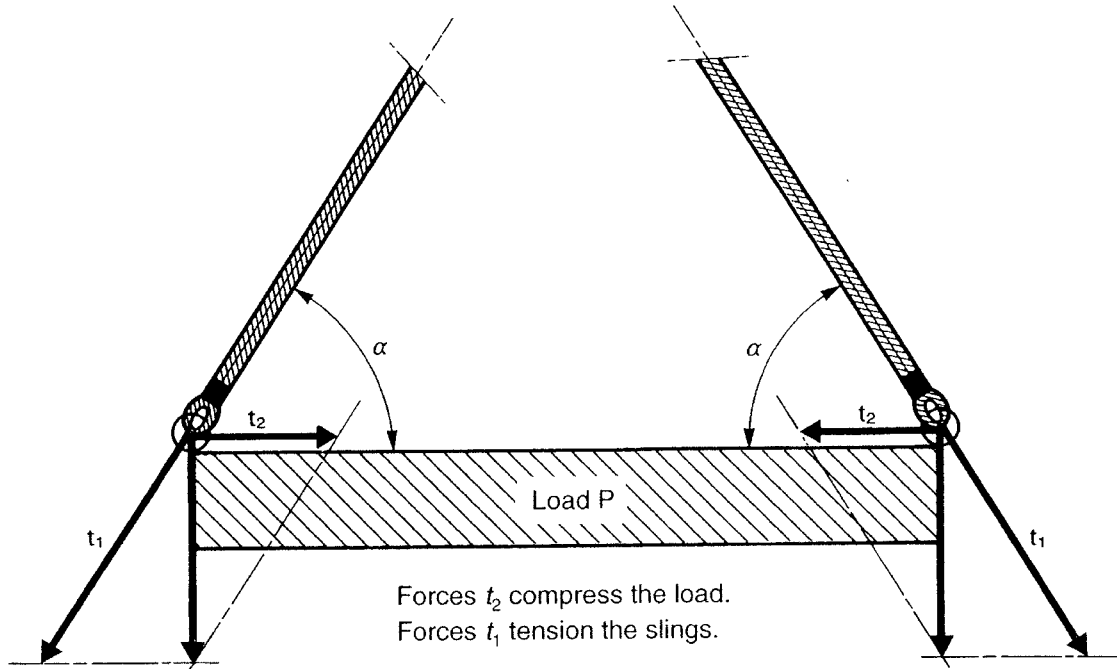

$$t_1 = \frac{P}{2 \sin \alpha}$$

II TENSION IN SLINGS AS A FUNCTION OF ANGLE α

For a load $P = 1000$ kg

α (degrees)	15	30	45	60	75	90
t_1 (kg)	1940	1000	700	580	520	500

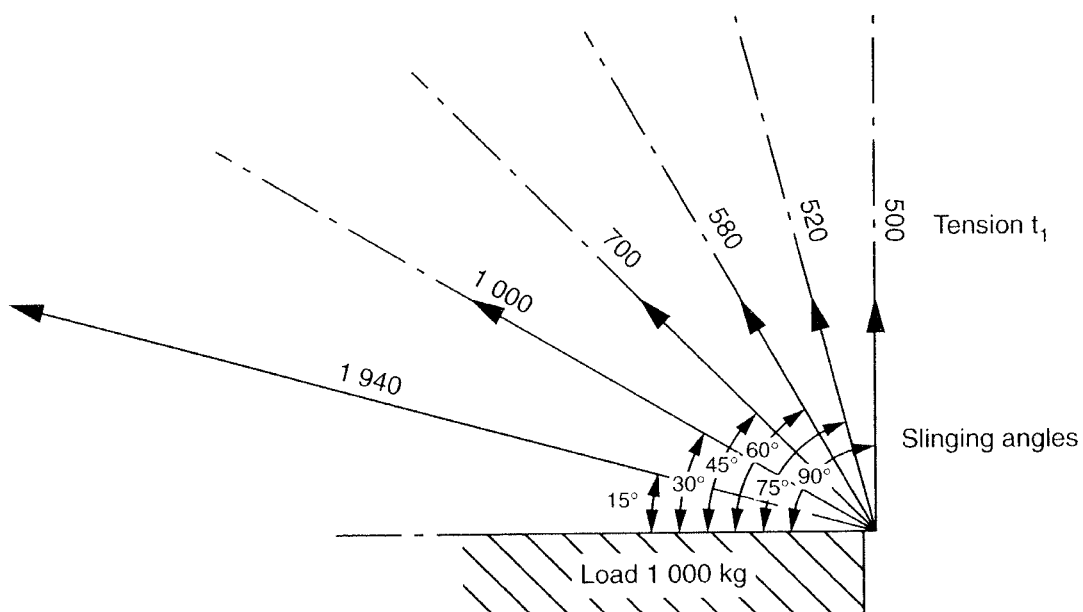

G

pumping and pressure losses

Mud pumps.....	G1
Pumping power.....	G2
Output in liters per stroke double acting duplex pumps based on liner size and piston rod diameter.....	G3-G4
Triplex pumps. Maximum pressure based on liner (kPa).....	G5
Output in liters per stroke of single acting triplex pumps (Volumetric efficiency 100%).....	G6
Mud cycle time.....	G7
Circulation flow rate (l/min) as a function of mud rising velocity opposite drill pipes (V_r in meters per minute) and hole / pipe annulus (V_a in liters per meter).....	G8-G9
Amount of drilled cuttings in mud.....	G10
Annular mud specific gravity d_{ann}	G11
Hydraulics.....	G12
Rheology.....	G13
Critical velocity based on rheological parameters (Practical units).....	G14
Pressure losses (General).....	G15
Pressure loss equations.....	G16-G18
Pressure drop in orifices.....	G19

Calculation of the bit nozzle velocity.....	G20
Pressure loss calculation.....	G21-G22
Table of coefficients B.....	G23-G29
Table of coefficients N_1 . Calculation of pressure losses in surface equipment.....	G30
Table of coefficients N_2 . Calculation of pressure losses in drill pipes.....	G31-G44
Table of coefficients N_3 . Calculation of pressure losses in drill collars.....	G45-G46
Calculations of pressure drop in nozzles. Combination of three nozzles.....	G47-G52
Calculations of pressure drop in nozzles. Combination of two nozzles.....	G53-G55
Table of nozzle areas. Combinations of three nozzles.....	G56
Table of nozzle areas. Combinations of two nozzles.....	G57
Table of nozzle areas.....	G58
Table of coefficients N_4 . Calculations of pressure loss in hole/drill collar annulus.....	G59-G63
Table of coefficients N_5 . Calculation of pressure loss in hole/pipe annulus.....	G64-G67
Equivalent lengths for special line connections (in meter).....	G68

MUD PUMPS

I THEORETICAL FLOW RATE

a. Duplex pump

$$Q_t = 0.0515 nL \left(D^2 - \frac{d^2}{2} \right)$$

b. Single-acting Triplex pump

$$Q_t = 0.0386 nLD^2$$

where:

Q_t = theoretical flow rate (l/m)

n = strokes per minute (strokes/min)

L = length of stroke (in)

D = liner diameter (in)

d = piston rod diameter (in)

II VOLUMETRIC EFFICIENCY η_v

$$\eta_v = \frac{Q_r}{Q_t}$$

Q_r = true measured flow rate (l/min)

III HYDRAULIC POWER P_h

$$P_h \text{ (kW)} = \frac{pQ_t}{60\,000}$$

$$P_h \text{ (hp)} = \frac{pQ_t}{44\,750}$$

where:

p = discharge pressure (kPa)

Q_t = flow rate (l/min)

$$\text{l/m} \times 0.264 = \text{gal/min}$$

PUMPING POWER

I TRUE HYDRAULIC POWER P_{hr}

$$P_{hr} \text{ (kW)} = \frac{\rho Q_r}{60\,000} \quad \text{or} \quad P_{hr} \text{ (kW)} = \frac{\rho Q_t \eta_v}{60\,000}$$

$$P_{hr} \text{ (hp)} = \frac{\rho Q_r}{44\,750} \quad \text{or} \quad P_{hr} \text{ (hp)} = \frac{\rho Q_t \eta_v}{44\,750}$$

II ENGINE POWER REQUIRED TO PRODUCE p AND Q_r

η_m = mechanical efficiency of pump

η_t = compound efficiency

$$P_m \text{ (kW)} = \frac{\rho Q_r}{60\,000 \eta_m \eta_t}$$

$$P_m \text{ (hp)} = \frac{\rho Q_r}{44\,750 \eta_m \eta_t}$$

III MAXIMUM SERVICE PRESSURE p_{\max} (kPa)

$$p_{\max} = \frac{10 F_{\max}}{S}$$

where:

F_{\max} = maximum load on cross head extension (*piston load*) (N)

S = average area under p_{\max} pressure (cm²)

$$S = 5.067 \left(D^2 - \frac{d^2}{2} \right) \quad \text{Duplex pump}$$

$$S = 5.067 D^2 \quad \text{Triplex pump}$$

where:

D = liner diameter (in)

d = piston rod diameter (in)

IV EFFICIENCY

η_m = mechanical efficiency of pump: 0.85 to 0.90

η_t = compound efficiency:

V-belts = 0.97

chains = 0.95

torque converter = 0.70 to 0.90

η_v = volumetric efficiency, which varies widely according to the state of the valves, the supercharging, and the type of fluid. In the best case $\eta_v = 0.98$ for a supercharged Triplex pump

OUTPUT IN LITERS PER STROKE DOUBLE ACTING DUPLEX PUMPS

based on liner size and piston rod diameter

Length of stroke 10"

Ø Piston (in)	8	7 3/4	7 1/2	7 1/4	7	6 3/4	6 1/2	6 1/4	6	5 3/4	5 1/2	5 1/4	5	4 3/4	4 1/2	4 1/4	4	3 3/4	3 1/2	3 1/4	3	
Ø Rod (in)																						
1 1/2				26.49	24.65	22.88	21.17	19.53	17.95	16.44	15.02	13.61	12.29	11.04	9.85	8.72	7.66	6.66	5.73	4.86	4.05	
1 5/8				26.38	24.54	22.77	21.06	19.42	17.84	16.33	14.91	13.50	12.18	10.93	9.74	8.61	7.55	6.55	5.62	4.75	3.94	
1 3/4				26.27	24.44	22.67	20.96	19.32	17.74	16.23	14.81	13.40	12.08	10.83	9.64	8.51	7.45	6.45	5.52	4.65	3.84	

Length of stroke 12"

Ø Piston (in)	8	7 3/4	7 1/2	7 1/4	7	6 3/4	6 1/2	6 1/4	6	5 3/4	5 1/2	5 1/4	5	4 3/4	4 1/2	4 1/4	4	3 3/4	3 1/2	3 1/4	3	
Ø Rod (in)																						
1 5/8				31.39	29.19	27.06	25.02	23.05	21.15	19.34	17.60	15.94	14.36	12.85	11.69	10.34	9.07					
1 7/8				31.24	29.04	26.91	24.87	22.90	21.00	19.19	17.45	15.79	14.21	12.70	11.27	10.07	8.80					
2				30.89	28.71	26.58	24.54	22.57	20.67	18.86	17.12	15.46	13.88	12.37	10.94	9.59	8.32					
2 1/4				35.87																		

Length of stroke 14"

Ø Piston (in)	8	7 3/4	7 1/2	7 1/4	7	6 3/4	6 1/2	6 1/4	6	5 3/4	5 1/2	5 1/4	5	4 3/4	4 1/2	4 1/4	4	3 3/4	3 1/2	3 1/4	3	
Ø Rod (in)																						
1 3/4				34.21	31.74	29.35	27.05	24.84	22.73	20.70	18.76	16.92	15.16	13.49								
2	44.68	41.85	39.10	36.44	33.87	31.40	29.01	26.71	24.50	22.39	20.36	18.42	16.58	14.82	13.15							
2 1/8	44.49	41.66	38.91	36.25	33.68	31.21	28.82	26.52	24.31	22.20	20.17	18.23	16.39	14.63	12.96							
2 1/4	44.30	41.47	38.72	36.06	33.49	31.02	28.63	26.33	24.12	22.01	19.98	18.04	16.20	14.44	12.77							
2 1/2	43.87	41.04	38.29	35.63	33.06	30.40	28.20	25.90	23.69	21.58	19.55	17.61	15.77	14.01	12.34							
2 5/8	43.64	40.81	38.06	35.40	32.83	30.36	27.97	25.67	23.46	21.35	19.32	17.38	15.54	13.78	12.11							

Length of stroke 15"

Ø Piston (in)	8	7 3/4	7 1/2	7 1/4	7	6 3/4	6 1/2	6 1/4	6	5 3/4	5 1/2	5 1/4	5	4 3/4	4 1/2	4 1/4	4	3 3/4	3 1/2	3 1/4	3	
Ø Rod (in)																						
2 1/4				44.43	41.48	38.63	30.67	28.21	25.84	23.58	21.40	19.33	17.35									
2 7/8				43.19	40.24	37.39	29.43	26.97	24.60	22.38	20.16	18.09	16.11									

l x 0.264 = gal

OUTPUT IN LITERS PER STROKE DOUBLE ACTING DUPLEX PUMPS

based on liner size and piston rod diameter

(continued)

Length of stroke 16"

Ø Piston (in)		8 1/2	8 1/4	8	7 3/4	7 1/2	7 1/4	7	6 3/4	6 1/2	6 1/4	6	5 3/4	5 1/2	5 1/4	5	4 3/4	4 1/2	4 1/4	
Ø Rod (in)																				
2 1/4		57.43	53.98	50.63	47.39	44.26	41.21	38.27	35.44	32.71	30.09	27.57	25.15	22.83	20.62	18.51	16.50			
2 1/2		56.94	53.49	50.14	46.90	43.76	40.72	37.78	34.95	32.22	29.60	27.08	24.66	22.34	20.13	18.02	16.01			
2 3/4		56.40	52.95	49.60	46.36	43.22	40.18	37.24	34.41	31.68	29.06	26.54	24.12	21.8	19.59	17.48	15.48			
3		55.81	52.36	49.01	45.77	42.63	39.59	35.65	33.82	31.09	28.47	25.95	23.53	21.21	19.00	16.89	14.88			
3 1/8		55.49	52.04	48.69	45.45	42.31	39.27	36.33	33.50	30.77	28.15	25.63	23.21	20.89	18.68	16.57	14.56			
3 1/4		54.47	51.02	47.67	44.43	41.29	38.25	35.31	32.48	29.75	27.13	24.61	22.19	19.87	17.66	15.55	13.54			

Length of stroke 18"

Ø Piston (in)		8 1/2	8 1/4	8	7 3/4	7 1/2	7 1/4	7	6 3/4	6 1/2	6 1/4	6	5 3/4	5 1/2	5 1/4	5	4 3/4	4 1/2	4 1/4	
Ø Rod (in)																				
2 1/4			60.72	56.95	53.30	49.77	46.35	43.05	39.87	36.80	33.85	31.01	28.29	25.68	23.19	20.82	18.56	16.41	14.39	
2 3/8			60.45	56.68	53.03	49.50	46.08	42.78	39.60	36.53	33.58	30.74	28.02	25.41	22.92	20.55	18.29	16.14	14.12	
2 1/2			60.17	56.40	52.75	49.22	45.80	42.50	39.32	36.25	33.30	30.46	27.74	25.13	22.64	20.27	18.01	15.86	13.84	
2 3/4			59.57	55.80	52.15	48.62	45.20	41.90	38.72	35.65	32.70	29.86	27.14	24.53	22.04	19.67	17.41	15.26	13.24	
3			58.90	53.13	51.48	47.95	44.53	41.23	38.05	34.98	32.03	29.19	26.47	23.86	21.37	19.00	16.74	14.59	12.57	
3 1/8			58.55	54.78	51.13	47.60	44.18	40.88	37.70	34.63	31.68	28.84	26.12	23.51	21.02	18.65	16.39	14.24	12.22	
3 1/4			58.18	54.41	50.76	47.23	43.81	40.51	37.33	34.26	31.31	28.47	25.75	23.14	20.65	18.28	16.02	13.87	11.85	

Length of stroke 20"

Ø Piston (in)		8 1/2	8 1/4	8	7 3/4	7 1/2	7 1/4	7	6 3/4	6 1/2	6 1/4	6	5 3/4	5 1/2	5 1/4	5	4 3/4	4 1/2	4 1/4	
Ø Rod (in)																				
2 1/2				62.68	58.62	54.70	50.90	47.23	43.69	40.28	37.00	33.85	30.92	27.93	25.16	22.52	20.01	17.63		
2 7/8				61.64	57.58	53.66	49.86	46.19	42.65	39.24	35.96	32.81	29.78	26.89	24.12	21.48	18.97	16.59		

1 x 0.264 = gal

TRIPLEX PUMPS

Maximum pressure based on liner (kPa)

Model	Maximum input power (kW)	Maximum speed (strokes/min)	Stroke		Liner size (mm and in)													
			(mm)	(in)	101.6	114.3	120.65	127	133.35	139.7	146.05	152.4	158.75	165.1	171.45	177.8	184.1	190.5
					4	4 1/2	4 3/4	5	5 1/4	5 1/2	5 3/4	6	6 1/4	6 1/2	6 3/4	7	7 1/4	7 1/2
Continental-Emsco																		
F800	597	150	228.6	9	38 510	30 440	27 370	24 750	22 480	20 440	18 720	17 170	15 820					
F1000	746	140	254.0	10		36 820	33 030	29 850	27 030	24 650	22 550	20 750	19 100					
F1300	969	120	304.8	12						31 140	28 450	26 140	24 090	22 480	20 660	19 230		
F1600	1193	120	304.8	12						38 320	35 010	32 160	29 640	27 660	25 430	23 600		
Gardner-Denver																		
PZ7	410	165	177.8	7						16 410	13 790			11 760		10 130		
PZ8	559	165	203.2	8	37 100	29 220		19 860		19 600	16 440	15 170						
PZ9	746	150	228.6	9		38 130		23 670		25 580	21 440	19 820		18 270	15 750			
PZ10	1006	130	254.0	10				30 920		35 790	30 070	25 620	22 090	22 090	19 220	16 740		
PZ11	1193	130	279.4	11						38 580	32 420	27 620	23 810	23 810	20 650	18 200	16 740	20 600
Ideco																		
T800	597	150	228.6	9						18 380	15 440			13 170		11 350		
T1000	746	140	254.0	10		27 460		22 220		24 680	20 700	17 640		17 640	15 200			
T1300	1048	130	304.8	12		36 810		29 800		31 120	26 150	22 280		22 280	19 220			
T1600	1292	130	304.8	12				37 660		38 300	32 190	27 430		27 430	23 650			
National																		
8P80	597	160	215.9	8 1/2						20 270	17 030							
9P100	746	150	234.9	9 1/4		30 300		24 550		24 860	20 890	19 240		19 240				
10P130	969	140	254.0	10		37 130		30 060		32 030	26 890	24 790		24 790				
12P160	1193	120	304.8	12				38 750		38 300	32 200	27 440	25 440	23 650	22 060			
Wirth																		
TPK1000	746	160	234.9	9 1/4		34 810	31 230	28 190	25 570	23 300	21 310	19 570	18 040					
TPK1300	969	150	254.0	10				36 150	32 790	29 880	27 370	25 120	23 160	21 400	19 840	18 460		
TPK1600	1193	120	304.8	12				38 330	35 020	38 330	35 020	32 160	29 670	27 430	25 440	23 640		

From *SI Drilling Manual*, First Edition, Canadian Association of Oilwell Drilling Contractors, Gulf.

kW x 1.34 = hp kPa x 0.145 = psi

OUTPUT IN LITERS PER STROKE OF SINGLE ACTING TRIPLEX PUMPS (Volumetric efficiency 100%)

Length of stroke (mm)		Liner size (mm and in)																		
		190.50	184.15	177.80	171.45	165.10	158.75	152.40	146.05	139.70	133.35	127.00	120.65	114.30	107.95	101.60	95.25	88.90	76.20	63.50
	(in)	7.50	7.25	7.00	6.75	6.50	6.25	6.00	5.75	5.50	5.25	5.00	4.75	4.50	4.25	4.00	3.75	3.50	3.00	2.50
127.00	5.00	10.86	10.15	9.46	8.80	8.16	7.54	6.95	6.38	5.84	5.32	4.83	4.36	3.91	3.49	3.09	2.71	2.36	1.74	1.21
133.35	5.25	11.40	10.65	9.93	9.24	8.56	7.92	7.30	6.70	6.13	5.59	5.07	4.57	4.10	3.66	3.24	2.85	2.40	1.82	1.27
139.70	5.50	11.95	11.16	10.41	9.68	8.97	8.30	7.64	7.02	6.42	5.85	5.31	4.79	4.30	3.84	3.40	2.99	2.60	1.91	1.33
146.05	5.75	12.49	11.67	10.88	10.12	9.38	8.67	7.99	7.34	6.72	6.12	5.55	5.01	4.50	4.01	3.55	3.12	2.72	2.00	1.39
152.40	6.00	13.03	12.18	11.35	10.56	9.79	9.05	8.34	7.66	7.01	6.39	5.79	5.23	4.69	4.18	3.71	3.26	2.84	2.08	1.45
158.75	6.25	13.57	12.68	11.82	11.00	10.20	9.43	8.69	7.98	7.30	6.65	6.03	5.44	4.89	4.36	3.86	3.39	2.96	2.17	1.51
165.10	6.50	14.12	13.19	12.30	11.43	10.60	9.80	9.03	8.30	7.59	6.92	6.27	5.66	5.08	4.53	4.02	3.53	3.07	2.26	1.57
171.45	6.75	14.66	13.70	12.77	11.87	11.01	10.18	9.38	8.62	7.88	7.18	6.52	5.88	5.28	4.71	4.17	3.67	3.19	2.35	1.63
177.80	7.00	15.20	14.21	13.24	12.31	11.42	10.56	9.73	8.94	8.18	7.45	6.76	6.10	5.47	4.88	4.32	3.80	3.31	2.43	1.69
184.15	7.25	15.75	14.71	13.72	12.75	11.83	10.93	10.08	9.26	8.47	7.72	7.00	6.32	5.67	5.06	4.48	3.94	3.43	2.52	1.75
190.50	7.50	16.29	15.22	14.19	13.19	12.23	11.31	10.42	9.57	8.76	7.98	7.24	6.53	5.86	5.23	4.63	4.07	3.55	2.61	1.81
196.85	7.75	16.83	15.73	14.66	13.63	12.64	11.69	10.77	9.89	9.05	8.25	7.48	6.75	6.06	5.40	4.79	4.21	3.67	2.69	1.87
203.20	8.00	17.37	16.24	15.14	14.07	13.05	12.07	11.12	10.21	9.34	8.51	7.72	6.97	6.25	5.58	4.94	4.34	3.78	2.78	1.93
209.55	8.25	17.92	16.74	15.61	14.51	13.46	12.44	11.47	10.53	9.64	8.78	7.96	7.19	6.45	5.75	5.10	4.48	3.90	2.87	1.99
215.90	8.50	18.46	17.25	16.08	14.95	13.87	12.82	11.81	10.85	9.93	9.05	8.20	7.40	6.65	5.93	5.25	4.62	4.02	2.95	2.05
222.25	8.75	19.00	17.76	16.55	15.39	14.27	13.20	12.16	11.17	10.22	9.31	8.45	7.62	6.84	6.10	5.41	4.75	4.14	3.04	2.11
228.60	9.00	19.55	18.27	17.03	15.83	14.68	13.57	12.51	11.49	10.51	9.58	8.69	7.84	7.04	6.28	5.56	4.89	4.26	3.13	2.17
234.95	9.25	20.09	18.77	17.50	16.27	15.09	13.95	12.86	11.81	10.80	9.84	8.93	8.06	7.23	6.45	5.71	5.02	4.38	3.21	2.23
241.30	9.50	20.63	19.28	17.97	16.71	15.50	14.33	13.20	12.13	11.10	10.11	9.17	8.28	7.43	6.63	5.87	5.16	4.49	3.30	2.29
254.00	10.00	21.72	20.29	18.92	17.59	16.31	15.08	13.90	12.77	11.68	10.64	9.65	8.71	7.82	6.97	6.18	5.43	4.73	3.47	2.41
266.70	10.50	22.80	21.31	19.87	18.47	17.13	15.84	14.59	13.40	12.26	11.17	10.14	9.15	8.21	7.32	6.49	5.70	4.97	3.65	2.53
279.40	11.00	23.89	22.32	20.81	19.35	17.94	16.59	15.29	14.04	12.85	11.71	10.62	9.58	8.60	7.67	6.80	5.97	5.20	3.82	2.65
292.10	11.50	24.98	23.34	21.76	20.23	18.76	17.34	15.98	14.68	13.43	12.24	11.10	10.02	8.99	8.02	7.10	6.24	5.44	4.00	2.78
304.80	12.00	26.06	24.35	22.70	21.11	19.58	18.10	16.68	15.32	14.02	12.77	11.58	10.45	9.38	8.37	7.41	6.52	5.68	4.17	2.90

l x 0.264 = gal

MUD CYCLE TIME

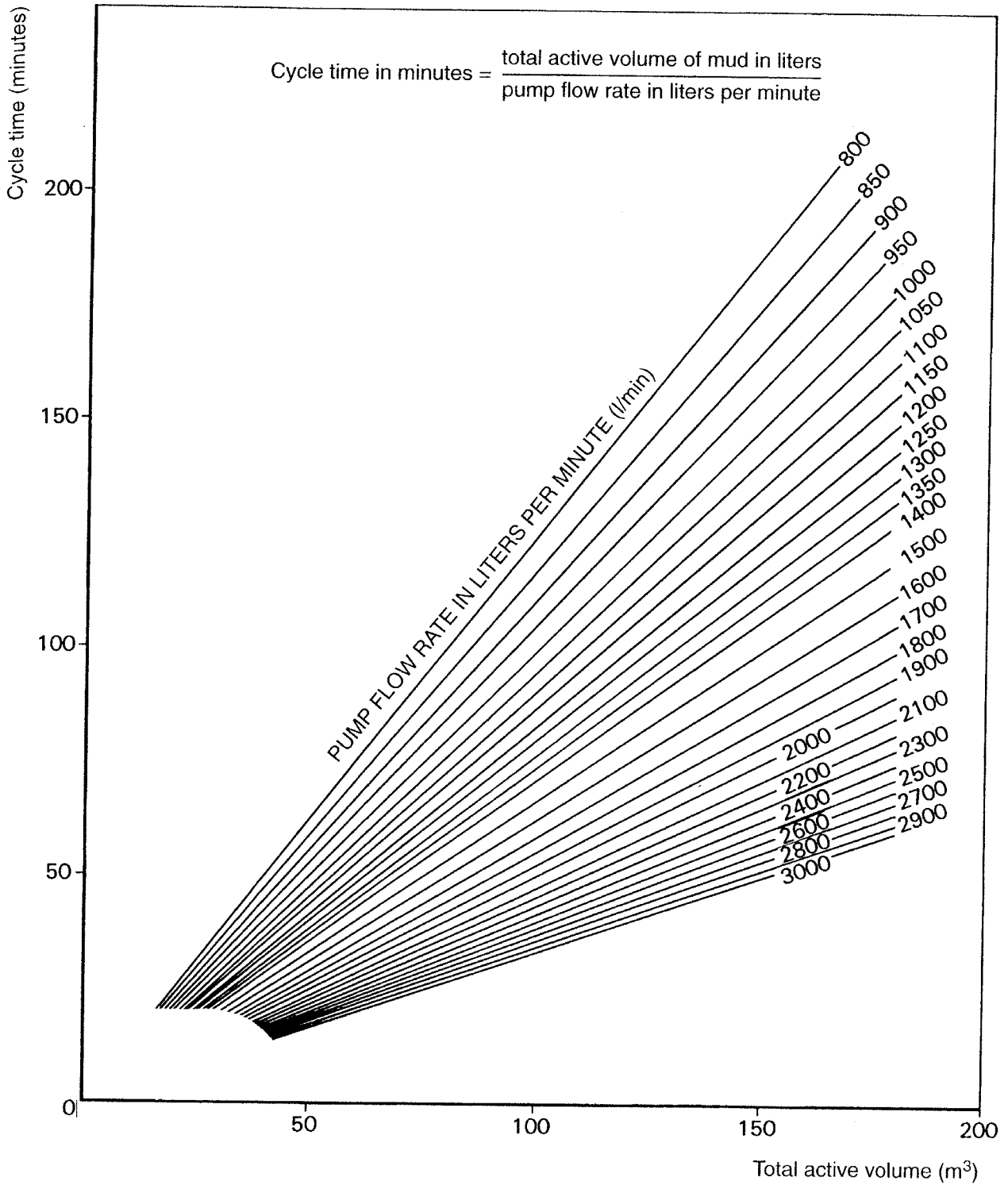

l × 0.264 = gal l/min × 0.264 = gal/min m³ × 6.29 = bbl

CIRCULATION FLOW RATE (l/min)

as a function of mud rising velocity opposite drill pipes (V_r in meters per minute) and hole/pipe annulus (V_a in liters per meter)

$$Q = V_r V_a$$

Hole size (in)	4 3/4		5 7/8		6		6 1/4		7 7/8			8 1/2			9 7/8			12 1/4		17 1/2	
	2 7/8	2 7/8	3 1/2	2 7/8	3 1/2	2 7/8	3 1/2	2 7/8	3 1/2	5	3 1/2	4 1/2	5	3 1/2	4 1/2	5	3 1/2	4 1/2	5	4 1/2	5
Annulus volume (l/m)	7.25	13.3	11.28	13.95	12.03	15.6	13.58	27.23	25.21	21.16	30.4	26.35	23.94	43.2	39.15	36.74	65.78	63.37	144.94	142.53	
10	73	133	113	140	120	156	136	272	252	212	304	264	239	432	392	367	658	634	1449	1425	
12	87	160	135	167	144	187	163	327	303	254	365	316	287	518	470	441	789	760	1739	1710	
14	102	186	158	195	168	218	190	381	353	296	426	369	335	605	548	514	921	887	2029	1995	
16	116	213	180	223	192	250	217	436	403	339	486	422	383	691	626	588	1052	1014	2319	2280	
18	131	239	203	251	217	281	244	490	454	381	547	474	431	778	705	661	1184	1141	2609	2566	
20	145	266	226	279	241	312	272	545	504	423	608	527	479	864	783	735	1316	1267	2899	2851	
22	160	293	248	307	265	343	299	599	555	466	669	580	527	950	861	808	1447	1394	3189	3136	
24	174	319	271	335	289	374	326	654	605	508	730	632	575	1037	940	882	1579	1521	3479	3421	
26	189	346	293	363	313	406	353	708	655	550	790	685	522	1123	1018	955	1710	1648	3768	3706	
28	203	372	316	391	337	437	380	762	706	592	851	738	670	1210	1096	1029	1842	1774	4058	3991	
30	218	399	338	419	361	468	407	817	756	635	912	791	718	1296	1175	1102	1973	1901	4348	4276	
32	232	426	361	446	385	499	435	871	807	677	973	843	766	1382	1253	1176	2105	2028	4638	4561	
34	247	452	384	474	409	530	462	926	857	719	1034	896	814	1469	1331	1249	2237	2155	4928	4846	
36	261	479	406	502	433	562	489	980	908	762	1094	949	862	1555	1409	1323	2368	2281			
38	276	505	429	530	457	593	516	1035	958	804	1155	1001	910	1642	1488	1396	2500	2408			
40	290	532	451	558	481	624	543	1089	1008	846	1216	1054	958	1728	1566	1470	2631	2535			
42	305	559	474	586	505	655	570	1144	1059	889	1277	1107	1005	1814	1644	1543	2763	2662			
44	319	585	496	614	529	686	598	1198	1109	931	1338	1159	1053	1901	1723	1617	2894	2788			
46	334	612	519	642	553	718	625	1253	1160	973	1398	1212	1101	1987	1801	1690	3026	2915			
48	348	638	541	670	577	749	652	1307	1210	1016	1459	1265	1149	2074	1879	1764	3157	3042			
50	363	665	564	698	602	780	679	1362	1261	1058	1520	1318	1197	2160	1958	1837	3289	3169			
52	377	692	587	725	626	811	706	1416	1311	1100	1581	1370	1245	2246	2036	1910	3421	3295			
54	392	718	609	753	650	842	733	1470	1361	1143	1642	1423	1293	2333	2114	1984	3552	3422			

l/m x 0.0805 = gal/ft l/m x 0.00192 = bb/ft m/min x 3.28 = ft/min

CIRCULATION FLOW RATE (l/min)
as a function of mud rising velocity opposite drill pipes (V_r in meters per minute)
and hole/pipe annulus (V_a in liters per meter) (continued)

$$Q = V_r V_a$$

Hole size (in)	4 3/4		5 7/8		6		6 1/4		7 7/8			8 1/2			9 7/8			12 1/4		17 1/2	
	2 7/8	2 7/8	2 7/8	3 1/2	2 7/8	3 1/2	2 7/8	3 1/2	3 1/2	4 1/2	5	3 1/2	4 1/2	5	3 1/2	4 1/2	5	4 1/2	5	4 1/2	5
Annulus volume (l/m)	7.25	13.3	11.28	12.03	15.6	13.58	27.23	25.21	21.16	30.4	26.35	23.94	43.2	39.15	36.74	65.78	63.37	144.94	142.53		
56	406	745	632	674	874	760	1525	1412	1185	1702	1476	1341	2419	2192	2057	3684	3549				
58	421	771	654	698	905	788	1579	1462	1227	1763	1528	1389	2506	2271	2131	3815	3675				
60	435	798	677	722	936	815	1634	1513	1270	1824	1581	1436	2592	2349	2204	3947	3802				
62	450	825	699	746	967	842	1688	1563	1312	1885	1634	1484	2678	2427	2278	4078	3929				
64	464	851	722	770	998	869	1743	1613	1354	1946	1686	1532	2765	2506	2351	4210	4056				
66	479	878	744	794	1030	896	1797	1664	1397	1739	1739	1580	2851	2584	2425	4341	4182				
68	493	904	767	818	1061	923		1714	1439	1792	1792	1628	2930	2662	2498	4473	4309				
70	508	931	790	842	1092	951		1765	1481	1845	1845	1676		2741	2572						
72	522	958	812	866	1123	978			1524	1897	1897	1724		2819	2645						
74	537	984	835	890	1154	1005			1566	1950	1950	1772		2997	2719						
76	551		857	914	1186	1032			1608			1819		2975	2792						
78	566		880	938		1059			1650			1867		2866							
80	580		902	962		1086			1693			1915		2939							
82	595		925	986		1114			1735			1963									
84	609		948	1011		1141			1777												
86			970	1035		1168															
88			993	1059		1195															
90			1015	1083																	

l/m x 0.0805 = gal/ft l/m x 0.00192 = bbl/ft m/min x 3.28 = ft/min

AMOUNT OF DRILLED CUTTINGS IN MUD

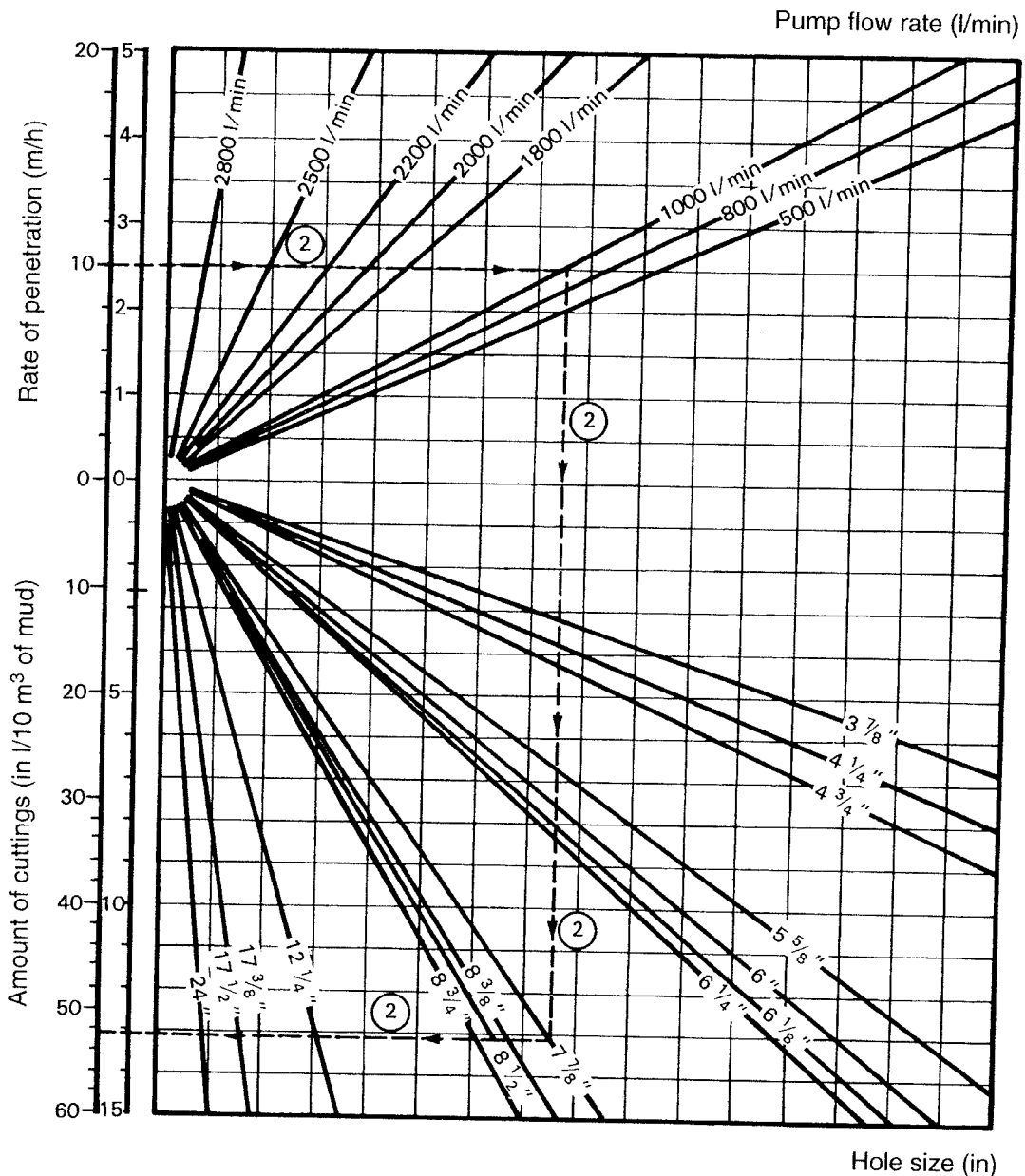

Examples:

1. Rate of penetration = 6 m/h
 Pump flow rate = 2000 l/min
 Hole size = 12.25 in
 Amount of cuttings = 38.0 l in 10 m³ of mud
2. Rate of penetration = 10 m/h
 Pump flow rate = 1000 l/m
 Hole size = 7 7/8 in
 Amount of cuttings = 52.2 l in 10 m³ of mud

where:

V = amount of cuttings (l/10 m³)

D = hole size (in)

A_v = rate of penetration (m/h)

Q = pump flow rate (l/m)

$$V = \frac{84.45 D^2 A_v}{Q}$$

m/h × 3.28 = ft/h l × 0.264 = gal l/min × 0.264 = gal/min

ANNULAR MUD SPECIFIC GRAVITY d_{ann}

d_{ann} depends on the following:

- (a) Rate of penetration A_v (m/h)
- (b) Initial specific gravity d_{init}
- (c) Mud flow rate Q (l/min)
- (d) Rate of fall of cuttings V_s (m/min)
- (e) Hole size D_f (in)
- (f) Pipe size D_t (in)

$$d_{\text{ann}} = d_{\text{init}} + \frac{D_f^2 A_v (2.5 - d_{\text{init}})}{118.41 Q - 60(D_f^2 - D_t^2) V_s}$$

Example:

$$D_f = 17 \frac{1}{2}''$$

$$D_t = 5''$$

$$d_{\text{init}} = 1.15$$

$$A_v = 25 \text{ m/h}$$

$$Q = 3200 \text{ l/min}$$

$$V_s = 10 \text{ m/min}$$

$$d_{\text{ann}} = d_{\text{init}} + 0.05 = 1.20$$

HYDRAULICS

(From the *Manuel de rhéologie des fluides de forage et laitiers de ciment*, Manual of Rheology of Drilling Fluids and Cement Slurries), Oil and Gas Exploration and Production Association, published by Éditions Technip, Paris, 1979).

Notation (Practical units)

Symbol	Unit	Signification
A	in^2	Total surface area of bit nozzles
d	kg/l	Fluid specific gravity
D	in	String inside diameter
D_o	in	Annulus outside diameter
D_i	in	Annulus inside diameter (outside string)
L	m	Length
p	kPa	Pressure losses, pressure
Q	l/min	Fluid flow rate
V	m/min	Fluid velocity
V_c	m/min	Critical fluid velocity
μ	cP	Dynamic viscosity
μ_p	cP	Plastic viscosity
τ_0	$\text{lb}/100 \text{ ft}^2$	Yield value
K	$\text{lb}\cdot\text{s}^n/100 \text{ ft}^2$	Consistency index
n		Rheological behavior index

RHEOLOGY

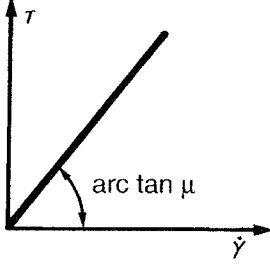
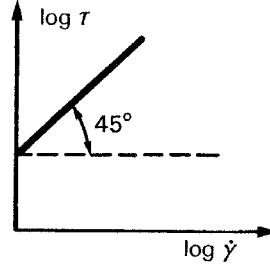
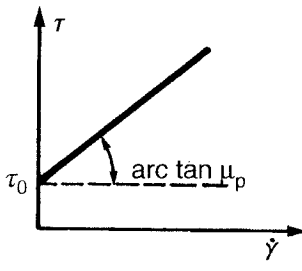
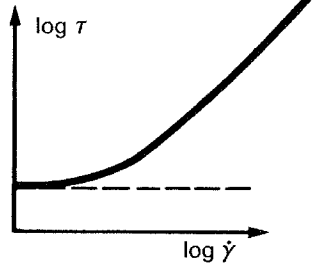
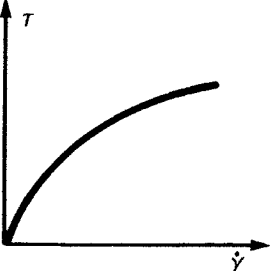
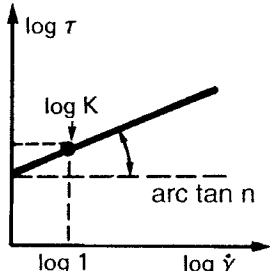
RHEOLOGICAL SYSTEM	RHEOLOGICAL EQUATION	FLOW CURVE CARTESIAN COORDINATES	FLOW CURVE LOGARITHMIC COORDINATES
Newtonian	$\tau = \mu \dot{\gamma}$		
Bingham or plastic	$\tau = \tau_0 + \mu_p \dot{\gamma}$		
"Power" or pseudoplastic or Ostwald	$\tau = K \dot{\gamma}^n$		

Rheological formulas for the Fann viscometer:

Apparent viscosity..... $\mu_a = \frac{\Theta_{600}}{2}$ (cP)

Yield value..... $\tau_0 = \Theta_{600} - 2(\Theta_{600} - \Theta_{300})$ (lb/100 ft²)

Plastic viscosity..... $\mu_p = \Theta_{600} - \Theta_{300}$ (cP)

Rheological index..... $n = 3.32 \log \left(\frac{\Theta_{600}}{\Theta_{300}} \right)$

Consistency index..... $K = \frac{\Theta_{600}}{(1020)^n} = \frac{\Theta_{300}}{(510)^n}$ (lb.sⁿ/100 ft²)

CRITICAL VELOCITY BASED ON RHEOLOGICAL PARAMETERS (Practical units)

BINGHAM FLUIDS

Circulation in drill pipes and drill collars:

$$V_c = \frac{2.48}{Dd} \left(\mu_p + \sqrt{\mu_p^2 + 73.57 \tau_0 D^2 d} \right)$$

Circulation in the annulus:

$$V_c = \frac{3.04}{(D_0 - D_1)d} \left(\mu_p + \sqrt{\mu_p^2 + 40.05 \tau_0 (D_0 - D_1)^2 d} \right)$$

OSTWALD FLUIDS

Circulation in drill pipes and drill collars:

$$V_c = 0.6 \left(\frac{(3470 - 1370n)K}{1.27d} \right)^{\frac{1}{2-n}} \left(\frac{3n+1}{1.25Dn} \right)^{\frac{n}{2-n}}$$

Circulation in the annulus:

$$V_c = 0.6 \left(\frac{(3470 - 1370n)K}{2.05d} \right)^{\frac{1}{2-n}} \left(\frac{2n+1}{0.64(D_0 - D_1)n} \right)^{\frac{n}{2-n}}$$

If $V < V_c$, the flow is laminar

If $V > V_c$, the flow is turbulent

with critical $Re = 2100$ (Bingham fluid)

critical $Re = 3470 - 1370n$ (Ostwald fluid).

PRESSURE LOSSES (General)

Fluid flow in pipes

Any fluid flowing in a pipe loses part of its energy, which is absorbed by dissipation in friction forces:

- (a) Internal friction due to its viscosity
- (b) External friction due to pipe roughness

This loss of energy is called the pressure drop or loss, and is expressed by the difference in the pressure of the fluid between two points of the pipe. For example, a circulating drilling mud has an initial energy represented by the pump discharge pressure. This energy is totally lost in the mud circuit because the mud pressure is zero when it returns to the pits. In this case, the pump discharge pressure represents the total pressure losses in the mud circuit.

These pressure losses occur:

- 1) In the surface equipment
- 2) In the drill pipes and drill collars
- 3) Through the bit
- 4) In the annulus between the well bore and the drill string

The pressure loss equations are a function of:

- (a) The rheology of the fluid
- (b) The type of flow (laminar or turbulent)
- (c) The pipe and hole geometry

The equations given below are used in drilling for:

- (a) A Newtonian fluid, a Bingham fluid and Ostwald fluid
- (b) Laminar and turbulent flow
- (c) A cylindrical pipe and annulus

PRESSURE LOSS EQUATIONS**NEWTONIAN FLUID****In drill string**

- Laminar flow:

$$\rho = \frac{QL\mu}{612.95D^4}$$

- Turbulent flow:

$$\rho = \frac{Ld^{0.8}Q^{1.8}\mu^{0.2}}{901.63D^{4.8}}$$

Annulus

- Laminar flow:

$$\rho = \frac{QL\mu}{408.63(D_0 + D_1)(D_0 - D_1)^3}$$

- Turbulent flow:

$$\rho = \frac{Ld^{0.8}Q^{1.8}\mu^{0.2}}{706.96(D_0 + D_1)^{1.8}(D_0 - D_1)^3}$$

PRESSURE LOSS EQUATIONS (continued)

BINGHAM FLUID

In drill string

- Laminar flow:

$$p = \frac{LQ\mu_p}{612.95D^4} + \frac{\tau_0 L}{13.26D}$$

- Turbulent flow:

$$p = \frac{Ld^{0.8}Q^{1.8}\mu_p^{0.2}}{901.63D^{4.8}}$$

Annulus

- Laminar flow:

$$p = \frac{LQ\mu_p}{408.63(D_0 + D_i)(D_0 - D_i)^3} + \frac{\tau_0 L}{13.26(D_0 - D_i)}$$

- Turbulent flow:

$$p = \frac{Ld^{0.8}Q^{1.8}\mu_p^{0.2}}{706.96(D_0 + D_i)^{1.8}(D_0 - D_i)^3}$$

PRESSURE LOSS EQUATIONS (continued)

OSTWALD FLUID

In drill string

- Laminar flow:

$$p = \frac{KL}{13.26D} \left[\frac{2.59Q}{D^3} \frac{(3n+1)}{n} \right]^n$$

- Turbulent flow:

$$p = \frac{(\log n + 2.5)dQ^2L}{586.94D^5} \left[\frac{D^4 K \left(\frac{2.59Q}{D^3} \frac{(3n+1)}{n} \right)^n}{18.07Q^2d} \right]^{\frac{1.4 + \log n}{7}}$$

Annulus

- Laminar flow:

$$p = \frac{KL}{13.26(D_0 - D_i)} \left[\frac{5.18Q}{(D_0 + D_i)(D_0 - D_i)^2} \left(\frac{2n+1}{n} \right) \right]^n$$

- Turbulent flow:

$$p = \frac{(\log n + 2.5)dQ^2L}{479.23(D_0 + D_i)^2(D_0 - D_i)^3} \left[\frac{[(D_0 + D_i)^2(D_0 - D_i)^2 K] \left[\frac{5.18Q}{(D_0 + D_i)(D_0 - D_i)^2} \left(\frac{2n+1}{n} \right) \right]^n}{22.13Q^2d} \right]^{\frac{1.4 + \log n}{7}}$$

PRESSURE DROP IN ORIFICES

$$p = \frac{dQ^2}{2959.41 C^2 A^2}$$

where:

- p = pressure drop (kPa)
- d = specific gravity (kg/l)
- Q = flow rate (l/min)
- A = total nozzle area (in²)
- C = orifice coefficient
 - C: 0.80 for non-jet bit
 - C: 0.95 for jet bit

Example:

- $d = 1.15$ kg/l
- $Q = 1500$ l/min
- 2 nozzles size 12/32 in
- 1 nozzle size 13/32 in

$$p = \frac{1.15 \times (1500)^2}{2959.41 \times (0.95)^2 \left[\frac{\pi}{4} \left(\frac{12^2 + 12^2 + 13^2}{32^2} \right) \right]^2} = 7885 \text{ kPa}$$

With table G 48: at 1500 l/min

- $p_d = 6857$ kPa
- $p = 6857 \times 1.15 = 7885$ kPa
- for $d = 1$

CALCULATION OF THE BIT NOZZLE VELOCITY

$$V = \frac{Q}{38.71A}$$

V = velocity (m/s)

Q = flow rate (l/min)

A = total nozzle area (in²)

Order of magnitude: 100 m/s < V < 120 m/s

CALCULATION OF THE HYDRAULIC POWER AT THE BIT NOZZLES: P_h

$$P_h \text{ (kW)} = \frac{p_d Q}{60\,000}$$

p_d = pressure drop in nozzles (kPa)

$$P_h \text{ (hp)} = \frac{p_d Q}{44\,750}$$

Q = flow rate (l/min)

HYDRAULIC PRESSURE AT BIT IN RELATION TO BIT AREA: P_{hHSI}

$$P_{hHSI} = \frac{P_d Q}{35\,140 D^2}$$

D = hole size (in)

P_{hHSI} = power (hp/in²)

Order of magnitude: 2 hp/in² < P_{hHSI} < 5 hp/in².

PRESSURE LOSS CALCULATION

The tables below can be used to calculate the pressure loss of a fluid circulating in a drilling installation.

The fluid is assumed to be a **Bingham fluid** in **turbulent** flow. The equations used are those in G 17 of the Drilling Data Handbook. The pressure losses have the form:

$$p = NB$$

with:

$$N = \frac{LQ^{1.8}}{901.63D^{4.8}} \quad (\text{in drill string})$$

$$N = \frac{LQ^{1.8}}{706.96(D_0 + D_1)^{1.8}(D_0 - D_1)^3} \quad (\text{annulus})$$

(The tables are calculated with $L = 100$ m)

$$B = d^{0.8} \mu_p^{0.2}$$

Important: Note that the coefficients N represent pressure losses for pure water.

To calculate the pressure losses in a circuit:

- a) **Find** in G 23 to G 29 the **coefficient B** corresponding to the circulating mud.
- b) **Note** the **lengths** of the different sections of identical geometry in hundreds of meters (drill pipe interior, drill collar interior, hole/ drill collar annulus, hole/ drill pipe annulus).
- c) **Find** in G 30 to G 67, the corresponding **coefficients N_1 , N_2 , N_3 , N_4 and N_5** .
- d) **Calculate** the **pressure drops** in the nozzles.

$$p_{\text{total}} = (N_1 + L_2 N_2 + L_3 N_3 + L_4 N_4 + L_5 N_5)B + p_d d$$

where:

L_2, L_3, \dots, L_5 = lengths of the different sections (100 m)

p_d = pressure drop in nozzles for $d = 1$ kg/l (kPa), G 47 to G 55

d = specific gravity (kg/liter)

N_1 = pressure loss coefficient in the surface equipment, G 30

N_2 = pressure loss coefficient in the drill pipes (kPa/100 m), G 31 to G 44

N_3 = pressure loss coefficient in the drill collars (kPa/100 m), G 45 to G 46

N_4 = pressure loss coefficient in hole/drill collar annulus (kPa/100 m), G 59 to G 63

N_5 = pressure loss coefficient in hole/drill pipe annulus (kPa/100 m), G 64 to G 67

PRESSURE LOSS CALCULATION (continued)

Calculation example

8 1/2 inch hole at a depth of 2300 m. The mud specific gravity $d = 1.15$ and its plastic viscosity $\mu_p = 22$ cP. The drilling flow rate $Q = 1500$ l/min. The surface equipment is No. 3.

The drill string consists of:

- (a) 170 m of 6 3/4 × 2 13/16 in drill collars.
- (b) 2130 m of 5 inch, 19.50 – E – NC50 drill pipes.

The bit is equipped with a combination of nozzles: 11/11/12.

I. Coefficient **$B = 2.08$** G 23

II.	1) Surface equipment	G 30	$N_1 = 95$
	2) In drill pipes	G 40	$N_2 = 57$
	3) In drill collars	G 45	$N_3 = 404$
	4) In nozzles	G 47	$p_d = 9608$ kPa
	5) Hole/DC	G 60	$N_4 = 102$
	6) Hole/pipe	G 66	$N_5 = 19$

III. Discharge pressure in normal circulation p_r :

$$\begin{aligned}
 p_r &= (N_1 + 21.3 N_2 + 1.7 N_3 + 1.7 N_4 + 21.3 N_5)B + p_d d \\
 &= (95 + 21.3 \times 57 + 1.7 \times 404 + 1.7 \times 102 + 21.3 \times 19)2.08 + 9608 \times 1.15 \\
 &= \mathbf{16\ 403\ kPa}
 \end{aligned}$$

TABLE OF COEFFICIENTS B

Specific gravity \ Viscosity	1.00	1.01	1.02	1.03	1.04	1.05	1.06	1.07	1.08	1.09	1.10	1.11	1.12	1.13	1.14	1.15	1.16	1.17	1.18
	2	1.15	1.16	1.17	1.18	1.19	1.19	1.20	1.21	1.22	1.23	1.24	1.25	1.26	1.27	1.28	1.28	1.29	1.30
4	1.32	1.33	1.34	1.35	1.36	1.37	1.38	1.39	1.40	1.41	1.42	1.43	1.44	1.46	1.47	1.48	1.49	1.50	1.51
6	1.43	1.44	1.45	1.47	1.48	1.49	1.50	1.51	1.52	1.53	1.54	1.56	1.57	1.58	1.59	1.60	1.61	1.62	1.63
8	1.52	1.53	1.54	1.55	1.56	1.58	1.59	1.60	1.61	1.62	1.64	1.65	1.66	1.67	1.68	1.70	1.71	1.72	1.73
10	1.58	1.60	1.61	1.62	1.64	1.65	1.66	1.67	1.69	1.70	1.71	1.72	1.74	1.75	1.76	1.77	1.78	1.80	1.81
12	1.64	1.66	1.67	1.68	1.70	1.71	1.72	1.74	1.75	1.76	1.77	1.79	1.80	1.81	1.83	1.84	1.85	1.86	1.88
14	1.70	1.71	1.72	1.74	1.75	1.76	1.78	1.79	1.80	1.82	1.83	1.84	1.86	1.87	1.88	1.90	1.91	1.92	1.94
16	1.74	1.76	1.77	1.78	1.80	1.81	1.82	1.84	1.85	1.87	1.88	1.89	1.91	1.92	1.93	1.95	1.96	1.97	1.99
18	1.78	1.80	1.81	1.83	1.84	1.85	1.87	1.88	1.90	1.91	1.92	1.94	1.95	1.97	1.98	1.99	2.01	2.02	2.03
20	1.82	1.84	1.85	1.86	1.88	1.89	1.91	1.92	1.94	1.95	1.96	1.98	1.99	2.01	2.02	2.04	2.05	2.06	2.08
22	1.86	1.87	1.89	1.90	1.91	1.93	1.94	1.96	1.97	1.99	2.00	2.02	2.03	2.05	2.06	2.08	2.09	2.10	2.12
24	1.89	1.90	1.92	1.93	1.95	1.96	1.98	2.01	2.02	2.02	2.04	2.05	2.07	2.08	2.10	2.11	2.13	2.14	2.16
26	1.92	1.93	1.95	1.96	1.98	2.00	2.01	2.03	2.04	2.06	2.07	2.09	2.10	2.12	2.13	2.15	2.16	2.18	2.19
28	1.95	1.96	1.98	1.99	2.01	2.02	2.04	2.06	2.07	2.10	2.11	2.12	2.13	2.15	2.16	2.18	2.19	2.21	2.22
30	1.97	1.99	2.01	2.02	2.04	2.05	2.07	2.08	2.10	2.12	2.13	2.15	2.16	2.18	2.19	2.21	2.22	2.24	2.25
32	2.00	2.02	2.03	2.05	2.06	2.08	2.10	2.11	2.13	2.14	2.16	2.17	2.19	2.21	2.22	2.24	2.25	2.27	2.28
34	2.02	2.04	2.06	2.07	2.09	2.10	2.12	2.14	2.15	2.17	2.18	2.20	2.22	2.23	2.25	2.26	2.28	2.30	2.31
36	2.05	2.06	2.08	2.10	2.11	2.13	2.15	2.16	2.18	2.19	2.21	2.23	2.24	2.26	2.27	2.29	2.31	2.32	2.34
38	2.07	2.09	2.10	2.12	2.14	2.15	2.17	2.19	2.20	2.22	2.23	2.25	2.27	2.28	2.30	2.31	2.33	2.35	2.36
40	2.09	2.11	2.12	2.14	2.16	2.17	2.19	2.21	2.22	2.24	2.26	2.27	2.29	2.31	2.32	2.34	2.35	2.37	2.39
42	2.11	2.13	2.15	2.16	2.18	2.20	2.21	2.23	2.25	2.26	2.28	2.30	2.31	2.33	2.35	2.36	2.38	2.39	2.41
44	2.13	2.15	2.17	2.18	2.20	2.22	2.23	2.25	2.27	2.28	2.30	2.32	2.33	2.35	2.37	2.38	2.40	2.42	2.43
46	2.15	2.17	2.18	2.20	2.22	2.24	2.25	2.27	2.29	2.30	2.32	2.34	2.35	2.37	2.39	2.40	2.42	2.44	2.46
48	2.17	2.19	2.20	2.22	2.24	2.26	2.27	2.29	2.31	2.32	2.34	2.36	2.37	2.39	2.41	2.43	2.44	2.46	2.48
50	2.19	2.20	2.22	2.24	2.26	2.27	2.29	2.31	2.33	2.34	2.36	2.38	2.39	2.41	2.43	2.45	2.46	2.48	2.50
52	2.20	2.22	2.24	2.26	2.27	2.29	2.31	2.33	2.34	2.36	2.38	2.40	2.41	2.43	2.45	2.46	2.48	2.50	2.52
54	2.22	2.24	2.26	2.27	2.29	2.31	2.33	2.34	2.36	2.38	2.40	2.41	2.43	2.45	2.47	2.48	2.50	2.52	2.54
56	2.24	2.25	2.27	2.29	2.31	2.33	2.34	2.36	2.38	2.40	2.41	2.43	2.45	2.47	2.48	2.50	2.52	2.54	2.55
58	2.25	2.27	2.29	2.31	2.32	2.34	2.36	2.38	2.40	2.41	2.43	2.45	2.47	2.48	2.50	2.52	2.54	2.55	2.57
60	2.27	2.29	2.30	2.32	2.34	2.36	2.38	2.39	2.41	2.43	2.45	2.47	2.48	2.50	2.52	2.54	2.55	2.57	2.59
62	2.28	2.30	2.32	2.34	2.36	2.37	2.39	2.41	2.43	2.45	2.46	2.48	2.50	2.52	2.55	2.57	2.59	2.60	2.62
64	2.30	2.32	2.33	2.35	2.37	2.39	2.41	2.43	2.44	2.46	2.48	2.50	2.52	2.53	2.55	2.57	2.59	2.60	2.62
66	2.31	2.33	2.35	2.37	2.39	2.40	2.42	2.44	2.46	2.48	2.49	2.51	2.53	2.55	2.57	2.59	2.60	2.62	2.64
68	2.33	2.34	2.36	2.38	2.40	2.42	2.44	2.45	2.47	2.49	2.51	2.53	2.55	2.56	2.58	2.60	2.62	2.64	2.65
70	2.34	2.36	2.38	2.39	2.41	2.43	2.45	2.47	2.49	2.51	2.52	2.54	2.56	2.58	2.60	2.62	2.63	2.65	2.67

TABLE OF COEFFICIENTS B (continued)

Specific gravity / Viscosity	1.19	1.20	1.21	1.22	1.23	1.24	1.25	1.26	1.27	1.28	1.29	1.30	1.31	1.32	1.33	1.34	1.35	1.36	1.37
	2	1.32	1.33	1.34	1.35	1.36	1.36	1.37	1.38	1.39	1.40	1.41	1.42	1.43	1.43	1.44	1.45	1.46	1.47
4	1.52	1.53	1.54	1.55	1.56	1.57	1.58	1.59	1.60	1.61	1.62	1.63	1.64	1.65	1.66	1.67	1.68	1.69	1.70
6	1.64	1.66	1.67	1.68	1.69	1.70	1.71	1.72	1.73	1.74	1.75	1.77	1.78	1.79	1.80	1.81	1.82	1.83	1.84
8	1.74	1.75	1.77	1.78	1.79	1.80	1.81	1.82	1.84	1.85	1.86	1.87	1.88	1.89	1.90	1.92	1.93	1.94	1.95
10	1.82	1.83	1.85	1.86	1.87	1.88	1.89	1.91	1.92	1.93	1.94	1.96	1.97	1.98	1.99	2.00	2.01	2.03	2.04
12	1.89	1.90	1.91	1.93	1.94	1.95	1.97	1.98	1.99	2.00	2.02	2.03	2.04	2.05	2.06	2.08	2.09	2.10	2.11
14	1.95	1.96	1.97	1.99	2.00	2.01	2.03	2.04	2.05	2.07	2.08	2.09	2.10	2.12	2.13	2.14	2.16	2.17	2.18
16	2.00	2.01	2.03	2.04	2.05	2.07	2.08	2.09	2.11	2.12	2.13	2.15	2.16	2.17	2.19	2.20	2.21	2.23	2.24
18	2.05	2.06	2.08	2.09	2.10	2.12	2.13	2.14	2.16	2.17	2.19	2.20	2.21	2.23	2.24	2.25	2.27	2.28	2.29
20	2.09	2.11	2.12	2.13	2.15	2.16	2.18	2.19	2.20	2.22	2.23	2.25	2.26	2.27	2.29	2.30	2.31	2.33	2.34
22	2.13	2.15	2.16	2.18	2.19	2.20	2.22	2.23	2.25	2.26	2.27	2.29	2.30	2.32	2.33	2.35	2.36	2.37	2.39
24	2.17	2.18	2.20	2.21	2.23	2.24	2.26	2.27	2.29	2.30	2.31	2.33	2.34	2.36	2.37	2.39	2.40	2.41	2.43
26	2.21	2.22	2.23	2.25	2.26	2.28	2.29	2.31	2.32	2.34	2.35	2.37	2.38	2.40	2.41	2.42	2.44	2.45	2.47
28	2.24	2.25	2.27	2.28	2.30	2.31	2.33	2.34	2.36	2.37	2.39	2.40	2.42	2.43	2.45	2.46	2.48	2.49	2.51
30	2.27	2.28	2.30	2.31	2.33	2.35	2.36	2.38	2.39	2.41	2.42	2.44	2.45	2.47	2.48	2.50	2.51	2.52	2.54
32	2.30	2.31	2.33	2.34	2.36	2.38	2.39	2.41	2.42	2.44	2.45	2.47	2.48	2.50	2.51	2.53	2.54	2.56	2.57
34	2.33	2.34	2.36	2.37	2.39	2.40	2.42	2.44	2.45	2.47	2.48	2.50	2.51	2.53	2.54	2.56	2.57	2.59	2.60
36	2.35	2.37	2.39	2.40	2.42	2.43	2.45	2.46	2.48	2.49	2.51	2.53	2.54	2.56	2.58	2.62	2.63	2.65	2.66
38	2.38	2.39	2.41	2.43	2.44	2.46	2.47	2.49	2.51	2.52	2.54	2.55	2.57	2.58	2.60	2.64	2.66	2.67	2.69
40	2.40	2.42	2.44	2.45	2.47	2.48	2.50	2.52	2.53	2.55	2.56	2.58	2.60	2.61	2.63	2.64	2.66	2.67	2.72
42	2.43	2.44	2.46	2.48	2.49	2.51	2.52	2.54	2.56	2.57	2.59	2.60	2.62	2.64	2.65	2.67	2.68	2.70	2.72
44	2.45	2.47	2.48	2.50	2.52	2.53	2.55	2.56	2.58	2.60	2.61	2.63	2.65	2.66	2.68	2.69	2.71	2.73	2.74
46	2.47	2.49	2.50	2.52	2.54	2.55	2.57	2.59	2.60	2.62	2.64	2.65	2.67	2.69	2.70	2.72	2.73	2.75	2.77
48	2.49	2.51	2.53	2.54	2.56	2.58	2.59	2.61	2.63	2.64	2.66	2.68	2.69	2.71	2.72	2.74	2.76	2.77	2.79
50	2.51	2.53	2.55	2.56	2.58	2.60	2.61	2.63	2.65	2.66	2.68	2.70	2.71	2.73	2.75	2.76	2.78	2.80	2.81
52	2.53	2.55	2.57	2.58	2.60	2.62	2.63	2.65	2.67	2.69	2.70	2.72	2.74	2.75	2.77	2.79	2.80	2.82	2.84
54	2.55	2.57	2.59	2.60	2.62	2.64	2.65	2.67	2.69	2.71	2.72	2.74	2.76	2.77	2.79	2.81	2.82	2.84	2.86
56	2.57	2.59	2.61	2.62	2.64	2.66	2.67	2.69	2.71	2.73	2.74	2.76	2.78	2.79	2.81	2.83	2.84	2.86	2.88
58	2.59	2.61	2.62	2.64	2.66	2.68	2.69	2.71	2.73	2.74	2.76	2.78	2.80	2.81	2.83	2.85	2.86	2.88	2.90
60	2.61	2.62	2.64	2.66	2.68	2.69	2.71	2.73	2.75	2.76	2.78	2.80	2.81	2.83	2.85	2.87	2.88	2.90	2.92
62	2.62	2.64	2.66	2.68	2.69	2.71	2.73	2.75	2.76	2.78	2.80	2.82	2.83	2.85	2.87	2.89	2.90	2.92	2.94
64	2.64	2.66	2.68	2.69	2.71	2.73	2.75	2.76	2.78	2.80	2.82	2.83	2.85	2.87	2.89	2.90	2.92	2.94	2.96
66	2.66	2.67	2.69	2.71	2.73	2.75	2.76	2.78	2.80	2.82	2.83	2.85	2.87	2.89	2.90	2.92	2.94	2.96	2.97
68	2.67	2.69	2.71	2.73	2.74	2.76	2.78	2.80	2.82	2.83	2.85	2.87	2.89	2.90	2.92	2.94	2.96	2.97	2.99
70	2.69	2.71	2.72	2.74	2.76	2.78	2.80	2.81	2.83	2.85	2.87	2.89	2.90	2.92	2.94	2.96	2.97	2.99	3.01

TABLE OF COEFFICIENTS B (continued)

Specific gravity \ Viscosity	1.38	1.39	1.40	1.41	1.42	1.43	1.44	1.45	1.46	1.47	1.48	1.49	1.50	1.51	1.52	1.53	1.54	1.55	1.56
	2	1.49	1.49	1.50	1.51	1.52	1.53	1.54	1.55	1.55	1.56	1.57	1.58	1.59	1.60	1.61	1.61	1.62	1.63
4	1.71	1.72	1.73	1.74	1.75	1.76	1.77	1.78	1.79	1.80	1.81	1.82	1.83	1.83	1.84	1.85	1.86	1.87	1.88
6	1.85	1.86	1.87	1.88	1.89	1.91	1.92	1.93	1.94	1.95	1.96	1.97	1.98	1.99	2.00	2.01	2.02	2.03	2.04
8	1.96	1.97	1.98	2.00	2.01	2.02	2.03	2.04	2.05	2.06	2.07	2.09	2.10	2.11	2.12	2.13	2.14	2.15	2.16
10	2.05	2.06	2.07	2.09	2.10	2.11	2.12	2.13	2.15	2.16	2.17	2.18	2.19	2.20	2.22	2.23	2.24	2.25	2.26
12	2.13	2.14	2.15	2.16	2.18	2.19	2.20	2.21	2.22	2.24	2.25	2.26	2.27	2.29	2.30	2.31	2.32	2.33	2.35
14	2.19	2.21	2.22	2.23	2.24	2.26	2.27	2.28	2.29	2.31	2.32	2.33	2.34	2.36	2.37	2.38	2.39	2.41	2.42
16	2.25	2.27	2.28	2.29	2.30	2.32	2.33	2.34	2.36	2.37	2.38	2.40	2.41	2.42	2.43	2.45	2.46	2.47	2.48
18	2.31	2.32	2.33	2.35	2.36	2.37	2.39	2.40	2.41	2.43	2.44	2.45	2.47	2.48	2.49	2.50	2.52	2.53	2.54
20	2.36	2.37	2.38	2.40	2.41	2.42	2.44	2.45	2.46	2.48	2.49	2.50	2.52	2.53	2.54	2.56	2.57	2.59	2.60
22	2.40	2.41	2.43	2.44	2.46	2.47	2.48	2.50	2.51	2.53	2.54	2.55	2.57	2.58	2.59	2.61	2.62	2.63	2.65
24	2.44	2.46	2.47	2.49	2.50	2.51	2.53	2.54	2.56	2.57	2.58	2.60	2.61	2.63	2.64	2.65	2.67	2.68	2.69
26	2.48	2.50	2.51	2.53	2.54	2.55	2.57	2.58	2.60	2.61	2.63	2.64	2.65	2.67	2.68	2.70	2.71	2.72	2.74
28	2.52	2.53	2.55	2.56	2.58	2.59	2.61	2.62	2.64	2.65	2.66	2.68	2.69	2.71	2.72	2.74	2.75	2.77	2.78
30	2.55	2.57	2.58	2.60	2.61	2.63	2.64	2.66	2.67	2.69	2.70	2.72	2.73	2.75	2.76	2.77	2.79	2.80	2.82
32	2.59	2.60	2.62	2.63	2.65	2.66	2.68	2.69	2.71	2.72	2.74	2.75	2.77	2.78	2.80	2.81	2.83	2.84	2.85
34	2.62	2.63	2.65	2.66	2.68	2.70	2.71	2.73	2.74	2.76	2.77	2.79	2.80	2.81	2.83	2.84	2.86	2.87	2.89
36	2.65	2.66	2.68	2.70	2.71	2.73	2.74	2.76	2.77	2.79	2.80	2.82	2.83	2.85	2.86	2.88	2.89	2.91	2.92
38	2.68	2.69	2.71	2.72	2.74	2.76	2.77	2.79	2.80	2.82	2.83	2.85	2.86	2.88	2.89	2.91	2.92	2.94	2.95
40	2.71	2.72	2.74	2.75	2.77	2.78	2.80	2.82	2.83	2.85	2.86	2.88	2.89	2.91	2.92	2.94	2.95	2.97	2.98
42	2.73	2.75	2.76	2.78	2.80	2.81	2.83	2.84	2.86	2.87	2.89	2.91	2.92	2.94	2.95	2.97	2.98	3.00	3.01
44	2.76	2.77	2.79	2.81	2.82	2.84	2.85	2.87	2.89	2.90	2.92	2.93	2.95	2.96	2.98	3.00	3.01	3.03	3.04
46	2.78	2.80	2.81	2.83	2.85	2.86	2.88	2.89	2.91	2.93	2.94	2.96	2.97	2.99	3.01	3.02	3.04	3.05	3.07
48	2.81	2.82	2.84	2.86	2.87	2.89	2.90	2.92	2.94	2.95	2.97	2.98	3.00	3.02	3.03	3.05	3.06	3.08	3.10
50	2.83	2.85	2.86	2.88	2.89	2.91	2.93	2.94	2.96	2.98	2.99	3.01	3.02	3.04	3.06	3.07	3.09	3.10	3.12
52	2.85	2.87	2.88	2.90	2.92	2.93	2.95	2.97	2.98	3.00	3.02	3.03	3.05	3.06	3.08	3.10	3.11	3.13	3.15
54	2.87	2.89	2.91	2.92	2.94	2.96	2.97	2.99	3.01	3.02	3.04	3.06	3.07	3.09	3.10	3.12	3.14	3.15	3.17
56	2.89	2.91	2.93	2.94	2.96	2.98	2.99	3.01	3.03	3.04	3.06	3.08	3.09	3.11	3.13	3.14	3.16	3.18	3.19
58	2.91	2.93	2.95	2.97	2.98	3.00	3.02	3.03	3.05	3.07	3.08	3.10	3.12	3.13	3.15	3.17	3.18	3.20	3.22
60	2.93	2.95	2.97	2.99	3.00	3.02	3.04	3.05	3.07	3.09	3.10	3.12	3.14	3.15	3.17	3.19	3.20	3.22	3.24
62	2.95	2.97	2.99	3.01	3.02	3.04	3.06	3.07	3.09	3.11	3.12	3.14	3.16	3.17	3.19	3.21	3.22	3.24	3.26
64	2.97	2.99	3.01	3.02	3.04	3.06	3.08	3.09	3.11	3.13	3.14	3.16	3.18	3.19	3.21	3.23	3.25	3.26	3.28
66	2.99	3.01	3.03	3.04	3.06	3.08	3.09	3.11	3.13	3.15	3.16	3.18	3.20	3.21	3.23	3.25	3.27	3.28	3.30
68	3.01	3.03	3.04	3.06	3.08	3.10	3.11	3.13	3.15	3.16	3.18	3.20	3.22	3.23	3.25	3.27	3.28	3.30	3.32
70	3.03	3.04	3.06	3.08	3.10	3.11	3.13	3.15	3.17	3.18	3.20	3.22	3.24	3.25	3.27	3.29	3.30	3.32	3.34

TABLE OF COEFFICIENTS B (continued)

Specific gravity \ Viscosity	1.57	1.58	1.59	1.60	1.61	1.62	1.63	1.64	1.65	1.66	1.67	1.68	1.69	1.70	1.71	1.72	1.73	1.74	1.75
	2	1.65	1.66	1.66	1.67	1.68	1.69	1.70	1.71	1.71	1.72	1.73	1.74	1.75	1.76	1.76	1.77	1.78	1.79
4	1.89	1.90	1.91	1.92	1.93	1.94	1.95	1.96	1.97	1.98	1.99	2.00	2.01	2.02	2.03	2.04	2.05	2.06	2.06
6	2.05	2.06	2.07	2.08	2.09	2.10	2.12	2.13	2.14	2.15	2.16	2.17	2.18	2.19	2.20	2.21	2.22	2.23	2.24
8	2.17	2.19	2.20	2.21	2.22	2.23	2.24	2.25	2.26	2.27	2.28	2.30	2.31	2.32	2.33	2.34	2.35	2.36	2.37
10	2.27	2.29	2.30	2.31	2.32	2.33	2.34	2.35	2.37	2.38	2.39	2.40	2.41	2.42	2.43	2.45	2.46	2.47	2.48
12	2.36	2.37	2.38	2.39	2.41	2.42	2.43	2.44	2.45	2.47	2.48	2.49	2.50	2.51	2.52	2.54	2.55	2.56	2.57
14	2.43	2.44	2.46	2.47	2.48	2.49	2.51	2.52	2.53	2.54	2.56	2.57	2.58	2.59	2.60	2.62	2.63	2.64	2.65
16	2.50	2.51	2.52	2.54	2.55	2.56	2.57	2.59	2.60	2.61	2.62	2.64	2.65	2.66	2.67	2.69	2.70	2.71	2.72
18	2.56	2.57	2.58	2.60	2.61	2.62	2.64	2.65	2.66	2.67	2.69	2.70	2.71	2.73	2.74	2.75	2.76	2.78	2.79
20	2.61	2.63	2.64	2.65	2.66	2.68	2.69	2.70	2.72	2.73	2.74	2.76	2.77	2.78	2.80	2.81	2.82	2.84	2.85
22	2.66	2.68	2.69	2.70	2.72	2.73	2.74	2.76	2.77	2.78	2.80	2.81	2.82	2.84	2.85	2.86	2.88	2.89	2.90
24	2.71	2.72	2.74	2.75	2.76	2.78	2.79	2.80	2.82	2.83	2.85	2.86	2.87	2.89	2.90	2.91	2.93	2.94	2.95
26	2.75	2.77	2.78	2.79	2.81	2.82	2.84	2.85	2.86	2.88	2.89	2.91	2.92	2.93	2.95	2.96	2.97	2.99	3.00
28	2.79	2.81	2.82	2.84	2.85	2.86	2.88	2.89	2.91	2.92	2.93	2.95	2.96	2.98	2.99	3.01	3.02	3.03	3.05
30	2.83	2.85	2.86	2.88	2.89	2.90	2.92	2.93	2.95	2.96	2.98	2.99	3.00	3.02	3.03	3.05	3.06	3.08	3.09
32	2.87	2.88	2.90	2.91	2.93	2.94	2.96	2.97	2.99	3.00	3.01	3.03	3.04	3.06	3.07	3.09	3.10	3.12	3.13
34	2.90	2.92	2.93	2.95	2.96	2.98	2.99	3.01	3.02	3.04	3.05	3.07	3.08	3.09	3.11	3.12	3.14	3.15	3.17
36	2.94	2.95	2.97	2.98	3.00	3.01	3.03	3.04	3.06	3.07	3.09	3.10	3.12	3.13	3.15	3.16	3.17	3.19	3.20
38	2.97	2.98	3.00	3.01	3.03	3.04	3.06	3.07	3.09	3.10	3.12	3.13	3.15	3.16	3.18	3.19	3.21	3.22	3.24
40	3.00	3.02	3.03	3.05	3.06	3.08	3.09	3.11	3.12	3.14	3.15	3.17	3.18	3.20	3.21	3.23	3.24	3.26	3.27
42	3.03	3.04	3.06	3.08	3.09	3.11	3.12	3.14	3.15	3.17	3.18	3.20	3.21	3.23	3.24	3.26	3.27	3.29	3.30
44	3.06	3.07	3.09	3.10	3.12	3.14	3.15	3.17	3.18	3.20	3.21	3.23	3.24	3.26	3.27	3.29	3.30	3.32	3.34
46	3.09	3.10	3.12	3.13	3.15	3.16	3.18	3.19	3.21	3.23	3.24	3.26	3.27	3.29	3.30	3.32	3.33	3.35	3.36
48	3.11	3.13	3.14	3.16	3.17	3.19	3.21	3.22	3.24	3.25	3.27	3.28	3.30	3.32	3.33	3.35	3.36	3.38	3.39
50	3.14	3.15	3.17	3.18	3.20	3.22	3.23	3.25	3.26	3.28	3.30	3.31	3.33	3.34	3.36	3.37	3.39	3.41	3.42
52	3.16	3.18	3.19	3.21	3.23	3.24	3.26	3.27	3.29	3.31	3.32	3.34	3.35	3.37	3.39	3.40	3.42	3.43	3.45
54	3.19	3.20	3.22	3.23	3.25	3.27	3.28	3.30	3.31	3.33	3.35	3.36	3.38	3.39	3.41	3.43	3.44	3.46	3.47
56	3.21	3.23	3.24	3.26	3.27	3.29	3.31	3.32	3.34	3.36	3.37	3.39	3.40	3.42	3.44	3.45	3.47	3.48	3.50
58	3.23	3.25	3.26	3.28	3.30	3.31	3.33	3.35	3.36	3.38	3.40	3.41	3.43	3.44	3.46	3.48	3.49	3.51	3.52
60	3.25	3.27	3.29	3.30	3.32	3.34	3.35	3.37	3.39	3.40	3.42	3.43	3.45	3.47	3.48	3.50	3.52	3.53	3.55
62	3.27	3.29	3.31	3.32	3.34	3.36	3.37	3.39	3.41	3.42	3.44	3.46	3.47	3.49	3.51	3.52	3.54	3.56	3.57
64	3.30	3.31	3.33	3.35	3.36	3.38	3.40	3.41	3.43	3.45	3.46	3.48	3.50	3.51	3.53	3.55	3.56	3.58	3.59
66	3.32	3.33	3.35	3.37	3.38	3.40	3.42	3.43	3.45	3.47	3.48	3.50	3.52	3.53	3.55	3.57	3.58	3.60	3.62
68	3.34	3.35	3.37	3.39	3.40	3.42	3.44	3.45	3.47	3.49	3.50	3.52	3.54	3.56	3.57	3.59	3.61	3.62	3.64
70	3.36	3.37	3.39	3.41	3.42	3.44	3.46	3.47	3.49	3.51	3.53	3.54	3.56	3.58	3.59	3.61	3.63	3.64	3.66

TABLE OF COEFFICIENTS B (continued)

Specific gravity \ Viscosity	1.76	1.77	1.78	1.79	1.80	1.81	1.82	1.83	1.84	1.85	1.86	1.87	1.88	1.89	1.90	1.91	1.92	1.93	1.94
	2	1.81	1.82	1.83	1.84	1.85	1.85	1.85	1.86	1.87	1.88	1.89	1.90	1.90	1.91	1.92	1.93	1.94	1.94
4	2.07	2.09	2.10	2.11	2.12	2.13	2.13	2.14	2.15	2.16	2.17	2.18	2.19	2.20	2.21	2.21	2.22	2.23	2.24
6	2.25	2.27	2.28	2.29	2.30	2.31	2.31	2.32	2.33	2.34	2.35	2.36	2.37	2.38	2.39	2.40	2.41	2.42	2.43
8	2.38	2.40	2.41	2.43	2.44	2.45	2.45	2.46	2.47	2.48	2.49	2.50	2.51	2.52	2.53	2.54	2.55	2.56	2.58
10	2.49	2.51	2.53	2.54	2.55	2.56	2.56	2.57	2.58	2.59	2.60	2.62	2.63	2.64	2.65	2.66	2.67	2.68	2.69
12	2.58	2.61	2.62	2.63	2.64	2.65	2.65	2.67	2.68	2.69	2.70	2.71	2.72	2.74	2.75	2.76	2.77	2.78	2.79
14	2.66	2.69	2.70	2.71	2.73	2.74	2.74	2.75	2.76	2.77	2.79	2.80	2.81	2.82	2.83	2.84	2.86	2.87	2.88
16	2.74	2.76	2.77	2.79	2.80	2.81	2.81	2.82	2.84	2.85	2.86	2.87	2.89	2.90	2.91	2.92	2.93	2.95	2.96
18	2.80	2.83	2.84	2.85	2.87	2.88	2.88	2.89	2.90	2.92	2.93	2.94	2.95	2.97	2.98	2.99	3.00	3.02	3.03
20	2.86	2.89	2.90	2.91	2.93	2.94	2.94	2.95	2.97	2.98	2.99	3.00	3.02	3.03	3.04	3.06	3.07	3.08	3.09
22	2.92	2.94	2.96	2.97	2.98	3.00	3.00	3.01	3.02	3.04	3.05	3.06	3.07	3.09	3.10	3.11	3.13	3.14	3.15
24	2.97	2.99	3.01	3.02	3.04	3.05	3.05	3.06	3.08	3.09	3.10	3.12	3.13	3.14	3.16	3.17	3.18	3.20	3.21
26	3.02	3.04	3.06	3.07	3.08	3.10	3.10	3.11	3.12	3.14	3.15	3.17	3.18	3.19	3.21	3.22	3.23	3.25	3.26
28	3.06	3.09	3.10	3.12	3.13	3.14	3.14	3.16	3.17	3.19	3.20	3.21	3.23	3.24	3.25	3.27	3.28	3.30	3.31
30	3.10	3.13	3.15	3.16	3.17	3.19	3.19	3.20	3.22	3.23	3.24	3.26	3.27	3.29	3.30	3.31	3.33	3.34	3.35
32	3.14	3.17	3.19	3.20	3.21	3.23	3.23	3.24	3.26	3.27	3.29	3.30	3.31	3.33	3.34	3.36	3.37	3.38	3.40
34	3.18	3.21	3.23	3.24	3.25	3.27	3.27	3.28	3.30	3.31	3.33	3.34	3.35	3.37	3.38	3.40	3.41	3.43	3.44
36	3.22	3.25	3.26	3.28	3.29	3.31	3.31	3.32	3.34	3.35	3.36	3.38	3.39	3.41	3.42	3.44	3.45	3.47	3.48
38	3.25	3.28	3.30	3.31	3.33	3.34	3.34	3.36	3.37	3.39	3.40	3.42	3.43	3.44	3.46	3.47	3.49	3.50	3.52
40	3.29	3.32	3.33	3.35	3.36	3.38	3.38	3.39	3.41	3.42	3.44	3.45	3.47	3.48	3.49	3.51	3.52	3.54	3.55
42	3.32	3.35	3.36	3.38	3.39	3.41	3.41	3.42	3.44	3.45	3.47	3.48	3.50	3.51	3.53	3.54	3.56	3.57	3.59
44	3.35	3.38	3.40	3.41	3.43	3.44	3.44	3.46	3.47	3.49	3.50	3.52	3.53	3.55	3.56	3.58	3.61	3.61	3.62
46	3.38	3.41	3.44	3.44	3.46	3.47	3.47	3.49	3.50	3.52	3.53	3.55	3.56	3.58	3.59	3.62	3.62	3.64	3.65
48	3.41	3.44	3.47	3.47	3.49	3.50	3.50	3.52	3.53	3.55	3.56	3.58	3.59	3.61	3.62	3.64	3.66	3.67	3.69
50	3.44	3.47	3.48	3.50	3.52	3.53	3.53	3.55	3.56	3.58	3.59	3.61	3.62	3.64	3.65	3.67	3.68	3.70	3.72
52	3.46	3.50	3.51	3.53	3.54	3.56	3.56	3.57	3.59	3.61	3.62	3.64	3.65	3.67	3.68	3.70	3.71	3.73	3.74
54	3.49	3.52	3.54	3.55	3.57	3.59	3.59	3.60	3.62	3.63	3.65	3.66	3.68	3.70	3.71	3.73	3.74	3.76	3.77
56	3.52	3.55	3.56	3.58	3.60	3.62	3.62	3.63	3.64	3.66	3.67	3.69	3.71	3.72	3.74	3.75	3.77	3.79	3.80
58	3.54	3.57	3.59	3.60	3.62	3.64	3.64	3.65	3.67	3.68	3.70	3.72	3.73	3.75	3.76	3.78	3.80	3.81	3.83
60	3.56	3.60	3.61	3.63	3.65	3.66	3.66	3.68	3.69	3.71	3.73	3.74	3.76	3.77	3.79	3.81	3.82	3.84	3.85
62	3.59	3.62	3.64	3.65	3.67	3.69	3.69	3.70	3.72	3.73	3.75	3.77	3.78	3.80	3.81	3.83	3.85	3.86	3.88
64	3.61	3.64	3.66	3.68	3.69	3.71	3.71	3.73	3.74	3.76	3.77	3.79	3.81	3.82	3.84	3.86	3.87	3.89	3.90
66	3.63	3.67	3.68	3.70	3.72	3.73	3.73	3.75	3.76	3.78	3.80	3.81	3.83	3.85	3.86	3.88	3.90	3.91	3.93
68	3.66	3.69	3.70	3.72	3.74	3.75	3.75	3.77	3.79	3.80	3.82	3.84	3.85	3.87	3.89	3.90	3.92	3.94	3.95
70	3.68	3.71	3.73	3.74	3.76	3.78	3.78	3.79	3.81	3.83	3.84	3.86	3.88	3.89	3.91	3.93	3.94	3.96	3.97

TABLE OF COEFFICIENTS B (continued)

Specific gravity \ Viscosity	1.95	1.96	1.97	1.98	1.99	2.00	2.01	2.02	2.03	2.04	2.05	2.06	2.07	2.08	2.09	2.10	2.11	2.12	2.13		
	2	1.96	1.97	1.98	1.98	1.99	2.00	2.01	2.02	2.02	2.03	2.04	2.05	2.06	2.06	2.07	2.08	2.09	2.10	2.11	2.12
4	2.25	2.26	2.27	2.28	2.29	2.30	2.31	2.32	2.32	2.33	2.34	2.35	2.36	2.37	2.38	2.39	2.40	2.41	2.42	2.43	2.44
6	2.44	2.45	2.46	2.47	2.48	2.49	2.50	2.51	2.52	2.53	2.54	2.55	2.56	2.57	2.58	2.59	2.60	2.61	2.62	2.63	2.64
8	2.59	2.60	2.61	2.62	2.63	2.64	2.65	2.66	2.67	2.68	2.69	2.70	2.71	2.72	2.73	2.74	2.75	2.76	2.77	2.78	2.79
10	2.70	2.72	2.73	2.74	2.75	2.76	2.77	2.78	2.79	2.80	2.81	2.83	2.84	2.85	2.86	2.87	2.88	2.89	2.90	2.91	2.92
12	2.80	2.82	2.83	2.84	2.85	2.86	2.87	2.88	2.90	2.91	2.92	2.93	2.94	2.95	2.96	2.98	2.99	3.00	3.01	3.02	3.03
14	2.89	2.90	2.92	2.93	2.94	2.95	2.96	2.98	2.99	3.00	3.01	3.02	3.03	3.05	3.06	3.07	3.08	3.09	3.10	3.11	3.12
16	2.97	2.98	3.00	3.01	3.02	3.03	3.04	3.06	3.07	3.08	3.09	3.10	3.12	3.13	3.14	3.15	3.16	3.17	3.18	3.19	3.20
18	3.04	3.05	3.07	3.08	3.09	3.10	3.12	3.13	3.14	3.15	3.17	3.18	3.19	3.20	3.21	3.22	3.23	3.24	3.25	3.26	3.27
20	3.11	3.12	3.13	3.14	3.16	3.17	3.18	3.20	3.21	3.22	3.23	3.25	3.26	3.27	3.28	3.30	3.31	3.32	3.33	3.34	3.35
22	3.17	3.18	3.19	3.20	3.22	3.23	3.24	3.26	3.27	3.28	3.30	3.31	3.32	3.33	3.35	3.36	3.37	3.38	3.39	3.40	3.41
24	3.22	3.23	3.25	3.26	3.27	3.29	3.30	3.31	3.33	3.34	3.35	3.37	3.38	3.39	3.41	3.42	3.43	3.44	3.45	3.46	3.47
26	3.27	3.29	3.30	3.31	3.33	3.34	3.35	3.37	3.38	3.39	3.41	3.42	3.43	3.44	3.46	3.47	3.49	3.50	3.51	3.52	3.53
28	3.32	3.34	3.35	3.36	3.38	3.39	3.40	3.42	3.43	3.44	3.46	3.47	3.49	3.50	3.51	3.53	3.54	3.55	3.56	3.57	3.58
30	3.37	3.38	3.40	3.41	3.42	3.44	3.45	3.47	3.48	3.49	3.51	3.52	3.53	3.55	3.56	3.57	3.59	3.60	3.62	3.63	3.64
32	3.41	3.43	3.44	3.45	3.47	3.48	3.50	3.51	3.52	3.54	3.55	3.57	3.58	3.59	3.61	3.62	3.63	3.65	3.66	3.68	3.69
34	3.45	3.47	3.48	3.50	3.51	3.52	3.54	3.55	3.57	3.58	3.59	3.61	3.62	3.64	3.65	3.66	3.68	3.69	3.71	3.72	3.73
36	3.49	3.51	3.52	3.54	3.55	3.57	3.58	3.59	3.61	3.62	3.64	3.65	3.66	3.68	3.69	3.71	3.72	3.74	3.75	3.76	3.77
38	3.53	3.55	3.56	3.58	3.59	3.60	3.62	3.63	3.65	3.66	3.68	3.69	3.70	3.72	3.73	3.75	3.76	3.78	3.79	3.80	3.81
40	3.57	3.58	3.60	3.61	3.63	3.64	3.66	3.67	3.68	3.70	3.71	3.73	3.74	3.76	3.77	3.79	3.80	3.81	3.82	3.84	3.85
42	3.60	3.62	3.63	3.65	3.66	3.68	3.69	3.71	3.72	3.74	3.75	3.76	3.78	3.79	3.81	3.82	3.84	3.85	3.87	3.88	3.89
44	3.64	3.65	3.67	3.68	3.70	3.71	3.73	3.74	3.76	3.77	3.79	3.80	3.81	3.83	3.84	3.86	3.87	3.89	3.90	3.91	3.92
46	3.67	3.68	3.70	3.71	3.73	3.74	3.76	3.77	3.79	3.80	3.82	3.83	3.85	3.86	3.88	3.89	3.91	3.92	3.94	3.95	3.96
48	3.70	3.72	3.73	3.75	3.76	3.78	3.79	3.81	3.82	3.84	3.85	3.87	3.88	3.90	3.91	3.93	3.94	3.96	3.97	3.99	4.00
50	3.73	3.75	3.76	3.78	3.79	3.81	3.82	3.84	3.85	3.87	3.88	3.90	3.91	3.93	3.94	3.96	3.97	3.99	4.01	4.02	4.04
52	3.76	3.78	3.79	3.81	3.82	3.84	3.85	3.87	3.88	3.90	3.91	3.93	3.94	3.96	3.97	4.00	4.01	4.02	4.04	4.05	4.07
54	3.79	3.80	3.82	3.84	3.85	3.87	3.88	3.90	3.91	3.93	3.94	3.96	3.97	3.99	4.00	4.02	4.04	4.05	4.07	4.08	4.10
56	3.82	3.83	3.85	3.86	3.88	3.89	3.91	3.93	3.94	3.96	3.97	3.99	4.00	4.02	4.03	4.05	4.09	4.11	4.12	4.14	4.15
58	3.84	3.86	3.87	3.89	3.91	3.92	3.94	3.95	3.97	3.98	4.00	4.01	4.03	4.04	4.06	4.08	4.09	4.11	4.12	4.14	4.15
60	3.87	3.89	3.90	3.92	3.93	3.95	3.96	3.98	4.00	4.01	4.03	4.04	4.06	4.07	4.09	4.11	4.12	4.14	4.15	4.16	4.18
62	3.89	3.91	3.93	3.94	3.96	3.97	3.99	4.01	4.02	4.04	4.05	4.07	4.09	4.10	4.12	4.13	4.15	4.16	4.18	4.19	4.21
64	3.92	3.94	3.95	3.97	3.98	4.00	4.02	4.03	4.05	4.06	4.08	4.10	4.11	4.13	4.14	4.16	4.18	4.19	4.20	4.22	4.23
66	3.94	3.96	3.98	3.99	4.01	4.02	4.04	4.06	4.07	4.09	4.10	4.12	4.14	4.15	4.17	4.18	4.20	4.21	4.22	4.24	4.26
68	3.97	3.98	4.00	4.02	4.03	4.05	4.06	4.08	4.10	4.11	4.13	4.15	4.16	4.18	4.19	4.21	4.23	4.24	4.25	4.27	4.28
70	3.99	4.01	4.02	4.04	4.06	4.07	4.09	4.10	4.12	4.14	4.15	4.17	4.19	4.20	4.22	4.23	4.25	4.27	4.28	4.29	4.31

TABLE OF COEFFICIENTS B (continued)

Specific gravity \ Viscosity	2.14	2.15	2.16	2.17	2.18	2.19	2.20	2.21	2.22	2.23	2.24	2.25	2.26	2.27	2.28	2.29	2.30	2.31	2.32
	2	2.11	2.12	2.13	2.13	2.14	2.15	2.16	2.17	2.17	2.18	2.19	2.20	2.21	2.21	2.22	2.23	2.24	2.24
4	2.43	2.43	2.44	2.45	2.46	2.47	2.48	2.49	2.50	2.51	2.52	2.52	2.53	2.54	2.55	2.56	2.57	2.58	2.59
6	2.63	2.64	2.65	2.66	2.67	2.68	2.69	2.70	2.71	2.72	2.73	2.74	2.75	2.76	2.77	2.78	2.79	2.80	2.81
8	2.79	2.80	2.81	2.82	2.83	2.84	2.85	2.86	2.87	2.88	2.89	2.90	2.91	2.92	2.93	2.94	2.95	2.96	2.97
10	2.91	2.92	2.93	2.95	2.96	2.97	2.98	2.99	3.00	3.01	3.02	3.03	3.04	3.05	3.06	3.08	3.09	3.10	3.11
12	3.02	3.03	3.04	3.05	3.07	3.08	3.09	3.10	3.11	3.12	3.13	3.14	3.16	3.17	3.18	3.19	3.20	3.21	3.22
14	3.12	3.13	3.14	3.15	3.16	3.17	3.19	3.20	3.21	3.22	3.23	3.24	3.25	3.27	3.28	3.29	3.30	3.31	3.32
16	3.20	3.21	3.22	3.24	3.25	3.26	3.27	3.28	3.30	3.31	3.32	3.33	3.34	3.35	3.37	3.38	3.39	3.40	3.41
18	3.28	3.29	3.30	3.31	3.33	3.34	3.35	3.36	3.37	3.39	3.40	3.41	3.42	3.43	3.45	3.46	3.47	3.48	3.49
20	3.35	3.36	3.37	3.38	3.40	3.41	3.42	3.43	3.45	3.46	3.47	3.48	3.50	3.51	3.52	3.53	3.54	3.56	3.57
22	3.41	3.42	3.44	3.45	3.46	3.47	3.49	3.50	3.51	3.52	3.54	3.55	3.56	3.58	3.59	3.60	3.61	3.63	3.64
24	3.47	3.48	3.50	3.51	3.52	3.54	3.55	3.56	3.57	3.59	3.60	3.61	3.63	3.64	3.65	3.66	3.68	3.69	3.70
26	3.53	3.54	3.55	3.57	3.58	3.59	3.61	3.62	3.63	3.64	3.66	3.67	3.68	3.70	3.71	3.72	3.74	3.75	3.76
28	3.58	3.59	3.61	3.62	3.63	3.65	3.66	3.67	3.69	3.70	3.71	3.73	3.74	3.75	3.77	3.78	3.79	3.80	3.82
30	3.63	3.64	3.66	3.67	3.68	3.70	3.71	3.72	3.74	3.75	3.76	3.78	3.79	3.80	3.82	3.83	3.84	3.86	3.87
32	3.68	3.69	3.70	3.72	3.73	3.74	3.76	3.77	3.79	3.80	3.81	3.83	3.84	3.85	3.87	3.88	3.89	3.91	3.92
34	3.72	3.73	3.75	3.76	3.78	3.79	3.80	3.82	3.83	3.85	3.86	3.87	3.89	3.90	3.91	3.93	3.94	3.96	3.97
36	3.76	3.78	3.79	3.81	3.82	3.83	3.85	3.86	3.88	3.89	3.90	3.92	3.93	3.95	3.96	3.97	3.99	4.00	4.01
38	3.80	3.82	3.83	3.85	3.86	3.88	3.89	3.90	3.92	3.93	3.95	3.96	3.97	3.99	4.00	4.02	4.03	4.04	4.06
40	3.84	3.86	3.87	3.89	3.90	3.92	3.93	3.94	3.96	3.97	3.99	4.00	4.02	4.03	4.04	4.06	4.07	4.09	4.10
42	3.88	3.90	3.91	3.92	3.94	3.95	3.97	3.98	4.00	4.01	4.03	4.04	4.05	4.07	4.08	4.10	4.11	4.13	4.14
44	3.92	3.93	3.95	3.96	3.98	3.99	4.01	4.02	4.03	4.05	4.06	4.08	4.09	4.11	4.12	4.14	4.15	4.16	4.18
46	3.95	3.97	3.98	4.00	4.01	4.03	4.04	4.06	4.07	4.09	4.10	4.11	4.13	4.14	4.16	4.17	4.19	4.20	4.22
48	3.99	4.00	4.02	4.03	4.05	4.06	4.08	4.09	4.11	4.12	4.13	4.15	4.16	4.18	4.19	4.21	4.22	4.24	4.25
50	4.02	4.03	4.05	4.06	4.08	4.09	4.11	4.12	4.14	4.15	4.17	4.18	4.20	4.21	4.23	4.24	4.26	4.27	4.29
52	4.05	4.07	4.08	4.10	4.11	4.13	4.14	4.16	4.17	4.19	4.20	4.22	4.23	4.25	4.26	4.28	4.29	4.31	4.32
54	4.08	4.10	4.11	4.13	4.14	4.16	4.17	4.19	4.20	4.22	4.23	4.25	4.26	4.28	4.29	4.31	4.32	4.34	4.35
56	4.11	4.13	4.14	4.16	4.17	4.19	4.20	4.22	4.23	4.25	4.26	4.28	4.29	4.31	4.32	4.34	4.36	4.37	4.39
58	4.14	4.16	4.17	4.19	4.20	4.22	4.23	4.25	4.26	4.28	4.29	4.31	4.32	4.34	4.36	4.37	4.39	4.40	4.42
60	4.17	4.18	4.20	4.22	4.23	4.25	4.26	4.28	4.29	4.31	4.32	4.34	4.35	4.37	4.39	4.40	4.42	4.43	4.45
62	4.20	4.21	4.23	4.24	4.26	4.27	4.29	4.31	4.32	4.34	4.35	4.37	4.38	4.40	4.41	4.43	4.44	4.46	4.48
64	4.22	4.24	4.25	4.27	4.29	4.30	4.32	4.33	4.35	4.36	4.38	4.40	4.41	4.43	4.44	4.46	4.47	4.49	4.50
66	4.25	4.26	4.28	4.30	4.31	4.33	4.34	4.36	4.38	4.39	4.41	4.42	4.44	4.45	4.47	4.49	4.50	4.52	4.53
68	4.27	4.29	4.31	4.32	4.34	4.35	4.37	4.39	4.40	4.42	4.43	4.45	4.46	4.48	4.50	4.51	4.53	4.54	4.56
70	4.30	4.31	4.33	4.35	4.36	4.38	4.39	4.41	4.43	4.44	4.46	4.47	4.49	4.51	4.52	4.54	4.55	4.57	4.59

TABLE OF COEFFICIENTS N_1

Calculation of pressure losses in surface equipment

$$P_{\text{surface equipment}} = N_1 B \text{ (kPa)}$$

	Case 1			Case 2			Case 3			Case 4		
	ID (in)	Length (ft)	Length (m)	ID (in)	Length (ft)	Length (m)	ID (in)	Length (ft)	Length (m)	ID (in)	Length (ft)	Length (m)
Stand pipe	3	40	12.19	3 1/2	40	12.19	4	45	13.72	4	45	13.72
Drilling hose	2	45	13.72	2 1/2	55	16.76	3	55	16.76	3	55	16.76
Kelly	2 1/4	40	12.19	3 1/4	40	12.19	3 1/4	40	12.19	4	40	12.19
Swivel	2	4	1.22	2 1/2	5	1.52	2 1/2	5	1.52	3	6	1.83

Débit (l/min)	Case 1	Case 2	Case 3	Case 4	Débit (l/min)	Case 1	Case 2	Case 3	Case 4
500	68	24	13	10	2 800	1 506	529	293	229
550	80	28	16	12	2 850	1 555	546	303	236
600	94	33	18	14	2 900	1 604	563	312	244
650	109	38	21	17	2 950	1 655	581	322	251
700	124	44	24	19	3 000	1 705	598	332	259
750	141	49	27	21	3 050	1 757	617	342	267
800	158	55	31	24	3 100	1 809	635	352	275
850	176	62	34	27	3 150	1 862	653	362	283
900	195	69	38	30	3 200	1 915	672	373	291
950	215	76	42	33	3 250	1 970	691	383	299
1 000	236	83	46	36	3 300	2 025	710	394	308
1 050	258	90	50	39	3 350	2 080	730	405	316
1 100	280	98	55	43	3 400	2 136	750	416	324
1 150	304	107	59	46	3 450	2 193	770	427	333
1 200	328	115	64	50	3 500	2 251	790	438	342
1 250	353	124	69	54	3 550	2 309	810	449	351
1 300	379	133	74	57	3 600	2 368	831	461	360
1 350	405	142	79	62	3 650	2 427	852	472	369
1 400	433	152	84	66	3 700	2 488	873	484	378
1 450	461	162	90	70	3 750	2 548	894	496	387
1 500	490	172	95	74	3 800	2 610	916	508	396
1 550	520	182	101	79	3 850	2 672	938	520	406
1 600	550	193	107	84	3 900	2 735	960	532	415
1 650	581	204	113	88	3 950	2 798	982	545	425
1 700	613	215	119	93	4 000	2 862	1 004	557	435
1 750	646	227	126	98	4 050	2 927	1 027	570	445
1 800	680	239	132	103	4 100	2 992	1 050	582	455
1 850	714	251	139	109	4 150	3 058	1 073	595	465
1 900	749	263	146	114	4 200	3 125	1 097	608	475
1 950	785	276	153	119	4 250	3 192	1 120	621	485
2 000	822	288	160	125	4 300	3 260	1 144	635	495
2 050	859	302	167	131	4 350	3 329	1 168	648	506
2 100	897	315	175	136	4 400	3 398	1 192	661	516
2 150	936	329	182	142	4 450	3 468	1 217	675	527
2 200	976	342	190	148	4 500	3 538	1 242	689	537
2 250	1 016	357	198	154	4 550	3 609	1 267	703	548
2 300	1 057	371	206	161	4 600	3 681	1 292	716	559
2 350	1 099	386	214	167	4 650	3 753	1 317	731	570
2 400	1 141	400	222	173	4 700	3 826	1 343	745	581
2 450	1 184	416	231	180	4 750	3 900	1 368	759	592
2 500	1 228	431	239	187	4 800	3 974	1 395	774	604
2 550	1 273	447	248	193	4 850	4 049	1 421	788	615
2 600	1 318	463	257	200	4 900	4 124	1 447	803	626
2 650	1 364	479	266	207	4 950	4 200	1 474	818	638
2 700	1 411	495	275	214	5 000	4 277	1 501	833	650
2 750	1 458	512	284	221					

l/min × 0.264 = gal/min

TABLE OF COEFFICIENTS N_2

Calculation of pressure losses in drill pipes $p_{int} = N_2 B$ (kPa/100 m)

Nominal pipe size (in)	2 7/8									
	2 3/8									
Nominal weight (lb/ft)	6.65									
Pipe inside diameter (in)	1.815									
Tool joint inside diameter (in)	2.151									
	1 13/16	1 3/4	1 3/8	2 5/32	2 1/8	2	1 7/8	1 3/4	1 5/8	1 1/2
100	25	26	30	11	11	11	12	12	13	15
150	52	53	62	23	23	24	25	26	28	30
200	88	89	104	39	39	40	41	43	46	51
250	131	133	156	58	58	60	62	65	69	76
300	183	185	216	81	81	83	86	90	96	106
350	241	244	286	106	107	110	113	119	127	140
400	306	310	363	135	136	139	144	151	161	177
450	379	383	449	167	168	172	178	186	199	219
500	458	463	543	202	203	208	215	225	241	265
550	544	550	644	240	241	247	255	268	286	315
600	636	643	754	281	281	289	299	313	334	368
650	734	743	870	324	326	334	345	361	386	425
700	839	849	995	371	373	381	394	413	441	486
750	950	962	1126	420	422	432	446	468	500	550
800	1067	1080	1265	472	474	485	501	525	561	618
850	1190	1205	1411	526	528	541	559	586	626	689
900	1319	1335	1564	583	586	600	620	649	694	764
950	1454	1472	1723	642	646	661	683	716	765	842
1 000	1594	1614	1890	705	708	725	749	785	839	923
1 050	1741	1762	2064	769	773	791	818	857	916	1 008
1 100	1893	1916	2244	837	841	860	889	932	996	1 096
1 150	2050	2076	2431	906	911	932	963	1 009	1 079	1 188
1 200	2214	2241	2624	978	983	1 006	1 040	1 090	1 165	1 282
1 250	2382	2412	2824	1 053	1 058	1 083	1 119	1 173	1 253	1 380
1 300	2557	2588	3 031	1 130	1 135	1 162	1 201	1 258	1 345	1 481
1 350	2736	2770	3 244	1 209	1 215	1 244	1 286	1 347	1 440	1 585
1 400	2921	2957	3 463	1 291	1 297	1 328	1 373	1 438	1 537	1 692
1 450	3 112	3 150	3 689	1 375	1 382	1 415	1 462	1 532	1 637	1 802
1 500	3 308	3 348	3 921	1 462	1 469	1 504	1 554	1 628	1 740	1 916
1 550	3 509	3 552	4 160	1 551	1 558	1 595	1 649	1 727	1 846	2 032
1 600	3 715	3 761	4 404	1 642	1 650	1 689	1 746	1 829	1 955	2 152
1 650	3 927	3 975	4 655	1 736	1 744	1 785	1 845	1 933	2 066	2 274
1 700	4 143	4 194	4 912	1 831	1 840	1 884	1 947	2 040	2 180	2 400
1 750	4 365	4 419	5 175	1 929	1 939	1 985	2 051	2 149	2 297	2 528
1 800	4 592	4 649	5 445	2 030	2 040	2 088	2 158	2 261	2 416	2 660
1 850	4 825	4 884	5 720	2 132	2 143	2 194	2 267	2 375	2 538	2 794
1 900	5 062	5 124	6 001	2 237	2 248	2 301	2 378	2 492	2 663	2 932
1 950	5 304	5 369	6 288	2 344	2 356	2 412	2 492	2 611	2 791	3 072
2 000	5 551	5 620	6 582	2 454	2 465	2 524	2 608	2 733	2 921	3 215

l/min x 0.264 = gal/min

TABLE OF COEFFICIENTS N_2 (continued)
Calculation of pressure losses in drill pipes $p_{int} = N_2 B$ (kPa/100 m)

Nominal pipe size (in)		3 1/2													
Nominal weight (lb/ft)		13.3					15.5								
Pipe inside diameter (in)		2.764					2.602								
Tool joint inside diameter (in)		3		2 11/16		2 9/16		2 7/16		2 1/8		2 1/4		2 1/8	
100	2	2	3	3	4	4	5	4	4	5	5	5	5	5	5
150	5	5	7	7	7	8	9	8	8	10	10	10	10	10	10
200	8	8	12	12	12	14	16	14	14	16	16	16	16	16	16
250	12	12	18	18	18	20	23	20	20	24	24	24	24	24	24
300	17	17	24	24	26	28	33	28	28	33	33	33	33	33	33
350	22	23	32	32	34	37	43	37	37	44	44	44	44	44	44
400	28	29	41	41	43	48	55	48	48	56	56	56	56	56	56
450	34	36	51	51	53	59	68	59	59	69	69	69	69	69	69
500	42	43	61	61	64	71	82	71	71	83	83	83	83	83	83
550	49	52	73	73	76	84	97	84	84	99	99	99	99	99	99
600	58	60	85	85	89	99	113	99	99	116	116	116	116	116	116
650	67	70	98	98	103	114	131	114	114	133	133	133	133	133	133
700	76	80	112	112	118	130	150	130	130	152	152	152	152	152	152
750	86	90	127	127	133	147	169	147	147	173	173	173	173	173	173
800	97	101	143	143	149	166	190	166	166	194	194	194	194	194	194
850	108	113	159	159	167	185	212	185	185	216	216	216	216	216	216
900	120	125	177	177	185	205	235	205	205	240	240	240	240	240	240
950	132	138	195	195	204	226	259	226	226	264	264	264	264	264	264
1 000	145	151	214	214	223	247	284	247	247	290	290	290	290	290	290
1 050	158	165	233	233	244	270	310	270	270	316	316	316	316	316	316
1 100	172	179	254	254	265	294	337	294	294	344	344	344	344	344	344
1 150	186	194	275	275	287	318	366	318	318	373	373	373	373	373	373
1 200	201	210	297	297	310	343	395	343	343	402	402	402	402	402	402
1 250	216	226	319	319	334	370	425	370	370	433	433	433	433	433	433
1 300	232	242	343	343	358	397	456	397	397	465	465	465	465	465	465
1 350	248	259	367	367	383	425	488	425	425	497	497	497	497	497	497
1 400	265	277	392	392	409	453	521	453	453	531	531	531	531	531	531
1 450	282	295	417	417	436	483	555	483	483	566	566	566	566	566	566

l/min x 0.264 = gal/min

TABLE OF COEFFICIENTS N_2 (continued)
Calculation of pressure losses in drill pipes $p_{int} = N_2 B$ (kPa/100 m)

Nominal pipe size (in)	3 1/2											
	9.5					13.3					15.5	
	2.992					2.764					2.602	
Nominal weight (lb/ft)												
Pipe inside diameter (in)												
Tool joint inside diameter (in)	3											
	3	2 11/16	2 11/16	2 11/16	2 7/16	2 7/16	2 1/8	2 9/16	2 9/16	2 7/16	2 1/4	2 1/8
1 500	300	314	443	452	463	513	590	601	626	651		
1 550	318	333	470	479	492	544	626	638	664	691		
1 600	337	352	498	508	520	576	662	675	703	731		
1 650	356	372	526	536	550	609	700	714	743	773		
1 700	376	393	555	566	580	643	739	753	784	816		
1 750	396	414	585	596	612	677	778	793	826	859		
1 800	416	435	616	627	643	713	819	835	869	904		
1 850	437	457	647	659	676	749	860	877	913	950		
1 900	459	480	678	692	709	785	903	920	958	996		
1 950	481	503	711	725	743	823	946	964	1 004	1 044		
2 000	503	526	744	758	778	861	990	1 009	1 051	1 093		
2 050	526	550	778	793	813	901	1 035	1 055	1 099	1 142		
2 100	550	575	812	828	849	940	1 081	1 102	1 148	1 193		
2 150	573	600	847	864	886	981	1 127	1 149	1 197	1 245		
2 200	598	625	883	900	923	1 023	1 175	1 198	1 248	1 297		
2 250	622	651	920	938	961	1 065	1 224	1 247	1 299	1 351		
2 300	647	677	957	975	1 000	1 108	1 273	1 298	1 352	1 405		
2 350	673	704	995	1 014	1 040	1 151	1 323	1 349	1 405	1 461		
2 400	699	731	1 033	1 053	1 080	1 196	1 374	1 401	1 459	1 517		
2 450	725	758	1 072	1 093	1 121	1 241	1 426	1 454	1 515	1 575		
2 500	752	787	1 112	1 133	1 162	1 287	1 479	1 508	1 571	1 633		
2 550	779	815	1 152	1 175	1 204	1 334	1 533	1 562	1 628	1 692		
2 600	807	844	1 193	1 216	1 247	1 381	1 587	1 618	1 685	1 752		
2 650	835	874	1 235	1 259	1 291	1 429	1 643	1 674	1 744	1 813		
2 700	864	903	1 277	1 302	1 335	1 478	1 699	1 732	1 804	1 875		
2 750	893	934	1 320	1 346	1 380	1 528	1 756	1 790	1 865	1 938		
2 800	922	965	1 363	1 390	1 425	1 578	1 814	1 849	1 926	2 002		
2 850	952	996	1 408	1 435	1 471	1 630	1 872	1 909	1 988	2 067		

l/min x 0.264 = gal/min

TABLE OF COEFFICIENTS N_2 (continued)
Calculation of pressure losses in drill pipes $p_{int} = N_2 B$ (kPa/100 m)

Nominal pipe size (in)	4												4 1/2
	14												13.75
Nominal weight (lb/ft)	3.34												3.958
Pipe inside diameter (in)	3 1/4												3 3/4
Tool joint inside diameter (in)	3 1/4	3	2 13/16	2 11/16	2 9/16	2 7/16	3 31/32	3 7/8	3 3/4	3 1/4	3 1/4	3 1/4	
	100	1	1	1	2	2	2	1	1	1	1	1	1
150	3	3	3	3	3	3	1	1	1	1	1	1	
200	5	5	5	5	6	6	2	2	2	2	2	2	
250	7	7	8	8	8	9	3	3	3	3	3	3	
300	10	10	11	11	11	12	4	4	4	4	4	4	
350	13	13	14	14	15	16	6	6	6	6	6	6	
400	17	17	18	18	19	20	7	7	7	7	7	7	
450	20	21	22	23	24	25	9	9	9	9	9	9	
500	25	26	27	28	29	30	11	11	11	11	11	11	
550	29	30	32	33	34	36	13	13	13	13	13	13	
600	34	36	37	38	40	42	15	15	15	15	15	15	
650	40	41	43	44	46	49	17	17	17	17	17	17	
700	45	47	49	50	53	56	20	20	20	20	20	20	
750	51	53	55	57	60	63	22	22	22	22	22	22	
800	58	60	62	64	67	71	25	25	25	25	25	25	
850	64	67	69	71	75	79	28	28	28	28	28	28	
900	71	74	77	79	83	87	31	31	31	31	31	31	
950	79	81	84	87	91	96	34	34	34	34	34	34	
1 000	86	89	93	96	100	105	38	38	38	38	38	38	
1 050	94	97	101	105	109	115	41	41	41	41	41	41	
1 100	102	106	110	114	119	125	45	45	45	45	45	45	
1 150	111	115	119	123	128	136	49	49	49	49	49	49	
1 200	120	124	129	133	139	146	52	52	52	52	52	52	
1 250	129	133	138	143	149	158	56	56	56	56	56	56	
1 300	138	143	148	154	160	169	61	61	61	61	61	61	
1 350	148	153	159	164	171	181	65	65	65	65	65	65	
1 400	158	163	170	175	183	193	69	69	69	69	69	69	
1 450	168	174	181	187	195	206	74	74	74	74	74	74	

l/min x 0.264 = gal/min

TABLE OF COEFFICIENTS N_2 (continued)
Calculation of pressure losses in drill pipes $p_{int} = N_2 B$ (kPa/100 m)

Nominal pipe size (in)	4										
	4 1/2										
Nominal weight (lb/ft)	14										
Pipe inside diameter (in)	3.34										
Tool joint inside diameter (in)	3.958										
Flow rate Q (l/min)	3 1/4	3	2 13/16	2 11/16	2 9/16	2 7/16	3 31/32	3 7/8	3 3/4	3 1/4	
	1 500	179	185	192	199	207	219	78	79	80	87
1 550	190	196	204	211	220	232	83	84	85	92	
1 600	201	208	216	223	233	246	88	89	90	97	
1 650	212	220	228	236	246	260	93	94	95	103	
1 700	224	232	241	249	260	274	98	99	100	108	
1 750	236	244	254	262	274	289	103	104	105	114	
1 800	248	257	267	276	288	304	109	110	111	120	
1 850	261	270	280	290	302	319	114	115	117	126	
1 900	273	283	294	304	317	335	120	121	122	133	
1 950	286	297	308	319	332	351	126	127	128	139	
2 000	300	310	322	333	348	367	131	132	134	145	
2 050	313	325	337	349	364	384	137	138	140	152	
2 100	327	339	352	364	380	401	143	145	146	159	
2 150	342	354	367	380	396	418	150	151	153	166	
2 200	356	369	383	396	413	436	156	157	159	173	
2 250	371	384	399	412	430	454	162	164	166	180	
2 300	386	399	415	429	447	472	169	170	172	187	
2 350	401	415	431	446	465	491	176	177	179	194	
2 400	416	431	448	463	483	510	182	184	186	202	
2 450	432	447	465	481	501	529	189	191	193	209	
2 500	448	464	482	498	520	549	196	198	200	217	
2 550	464	481	499	516	539	568	203	205	208	225	
2 600	481	498	517	535	558	589	211	212	215	233	
2 650	498	515	535	553	577	609	218	220	223	241	
2 700	515	533	553	572	597	630	226	227	230	249	
2 750	532	551	572	592	617	651	233	235	238	258	
2 800	549	569	591	611	638	673	241	243	246	266	
2 850	567	587	610	631	658	694	249	251	254	275	

l/min x 0.264 = gal/min

TABLE OF COEFFICIENTS N_2 (continued)
Calculation of pressure losses in drill pipes $p_{int} = N_2 B$ (kPa/100 m)

Nominal pipe size (in)	4										4 1/2														
	14										13.75														
Nominal weight (lb/ft)	3.34										3.958														
Pipe inside diameter (in)	3 1/4										3 7/8			3 3/4			3 1/4								
Tool joint inside diameter (in)	3										2 13/16			2 11/16			2 9/16			2 7/16			3 31/32		
2 900	585	606	629	651	679	717	755	777	811	834	855	306	309	312	256	259	262	284							
2 950	604	625	649	671	700	739	765	799	834	880	315	317	321	264	267	270	293								
3 000	622	644	669	692	722	762	788	821	857	904	324	326	330	273	275	278	301								
3 050	641	663	689	713	744	785	811	844	880	929	333	335	339	281	283	287	311								
3 100	660	683	710	734	766	808	832	867	904	954	341	344	349	289	291	295	320								
3 150	679	703	730	755	788	832	855	890	928	979	341	344	349	298	300	304	329								
3 200	699	723	751	777	811	855	880	913	953	1 005	306	309	312	306	309	312	339								
3 250	718	744	773	799	834	880	904	937	977	1 031	315	317	321	315	317	321	348								
3 300	739	765	794	821	857	904	928	961	1 002	1 057	324	326	330	324	326	330	358								
3 350	759	786	816	844	880	929	953	985	1 027	1 084	333	335	339	333	335	339	368								
3 400	779	807	838	867	904	954	977	1 009	1 053	1 111	341	344	349	341	344	349	378								
3 450	800	828	860	890	928	979	1 005	1 031	1 079	1 138	351	353	358	351	353	358	388								
3 500	821	850	883	913	953	1 005	1 031	1 061	1 105	1 166	360	363	367	360	363	367	398								
3 550	842	872	906	937	977	1 031	1 057	1 084	1 121	1 183	369	372	377	369	372	377	408								
3 600	864	894	929	961	1 002	1 057	1 084	1 111	1 158	1 221	378	382	386	378	382	386	419								
3 650	885	917	952	985	1 027	1 084	1 111	1 138	1 184	1 250	388	391	396	388	391	396	429								
3 700	907	939	976	1 009	1 053	1 111	1 138	1 166	1 211	1 278	398	401	406	398	401	406	440								
3 750	930	962	1 000	1 034	1 079	1 138	1 166	1 193	1 239	1 307	407	411	416	407	411	416	451								
3 800	952	986	1 024	1 059	1 105	1 166	1 193	1 221	1 267	1 336	417	421	426	417	421	426	461								
3 850	975	1 009	1 048	1 084	1 131	1 193	1 221	1 250	1 294	1 366	427	431	436	427	431	436	472								
3 900	998	1 033	1 073	1 109	1 158	1 221	1 250	1 278	1 323	1 396	437	441	446	437	441	446	483								
3 950	1 021	1 057	1 098	1 135	1 184	1 250	1 278	1 307	1 351	1 426	447	451	457	447	451	457	495								
4 000	1 044	1 081	1 123	1 161	1 211	1 278	1 307	1 336	1 380	1 457	458	461	467	458	461	467	506								
4 050	1 068	1 105	1 148	1 187	1 239	1 307	1 336	1 366	1 410	1 483	468	472	478	468	472	478	517								
4 100	1 092	1 130	1 174	1 214	1 267	1 336	1 366	1 396	1 440	1 514	478	482	488	478	482	488	529								
4 150	1 116	1 155	1 200	1 241	1 294	1 366	1 396	1 426	1 470	1 544	489	493	499	489	493	499	541								
4 200	1 140	1 180	1 226	1 268	1 323	1 396	1 426	1 457	1 501	1 575	500	504	510	500	504	510	552								
4 250	1 164	1 206	1 252	1 295	1 351	1 426	1 457	1 483	1 527	1 601	510	514	521	510	514	521	564								

l/min x 0.264 = gal/min

TABLE OF COEFFICIENTS N_2 (continued)
Calculation of pressure losses in drill pipes $p_{int} = N_2 B$ (kPa/100 m)

Nominal pipe size (in)		4 1/2										
Nominal weight (lb/ft)		16.6										
Pipe inside diameter (in)		3.826										
Tool joint inside diameter (in)		3.64										
		3 3/4	3 1/2	3 1/4	3	2 3/4	2 11/16	2 1/2	3 5/8	3 1/2	3 1/4	3
100		1	1	1	1	1	1	1	1	1	1	1
150		1	2	2	2	2	2	2	2	2	2	2
200		2	3	3	3	3	3	3	3	3	3	3
250		4	4	4	4	4	4	4	4	4	4	4
300		5	5	5	5	5	5	5	5	5	5	5
350		7	7	7	6	6	7	7	6	7	7	7
400		9	9	9	8	8	9	10	9	9	9	9
450		11	11	11	10	11	11	12	11	11	11	11
500		13	13	14	12	13	14	15	13	14	14	14
550		15	16	16	15	16	17	18	16	16	17	18
600		18	18	19	17	19	20	22	19	20	20	21
650		21	21	22	20	22	23	26	23	23	24	25
700		24	24	25	23	26	27	30	26	26	27	29
750		27	27	29	27	29	30	34	30	30	31	33
800		30	31	32	30	33	34	38	34	34	35	37
850		33	34	36	34	37	39	43	38	38	40	42
900		37	38	40	38	42	43	48	42	43	44	46
950		41	42	44	42	46	48	53	47	47	49	51
1 000		45	46	48	47	51	53	59	52	52	54	57
1 050		49	50	52	56	56	58	64	57	57	59	62
1 100		53	55	57	61	61	63	70	62	62	65	68
1 150		58	59	62	66	66	68	76	67	68	70	74
1 200		62	64	67	71	72	74	83	73	74	76	80
1 250		67	69	72	76	84	86	89	78	79	82	86
1 300		72	74	77	82	90	92	103	84	86	88	93
1 350		77	79	82	88	96	99	110	91	92	95	100
1 400		82	84	88	93	103	106	118	97	98	102	107
1 450		87	90	94	100	109	112	126	104	105	108	114
									110	112	116	121

l/min x 0.264 = gal/min

TABLE OF COEFFICIENTS N_2 (continued)
Calculation of pressure losses in drill pipes $p_{int} = N_2 B$ (kPa/100 m)

Nominal pipe size (in)		4 1/2										
Nominal weight (lb/ft)		16.6										
Pipe inside diameter (in)		3.826										
Tool joint inside diameter (in)		3										
		3 3/4	3 1/2	3 1/4	3	2 3/4	2 11/16	2 1/2	3 5/8	3 1/2	3 1/4	3
1 500		93	95	100	106	116	120	133	117	119	123	129
1 550		98	101	106	112	123	127	142	124	126	130	137
1 600		104	107	112	119	130	134	150	132	133	138	145
1 650		110	113	118	126	138	142	158	139	141	146	153
1 700		116	120	125	133	145	150	167	147	149	154	162
1 750		123	126	131	140	153	158	176	155	157	162	170
1 800		129	133	138	147	161	166	185	163	165	170	179
1 850		135	139	145	154	169	174	195	171	173	179	188
1 900		142	146	152	162	178	183	204	179	182	188	198
1 950		149	153	160	170	186	192	214	188	190	197	207
2 000		156	160	167	178	195	201	224	197	199	206	217
2 050		163	168	175	186	204	210	234	206	208	215	226
2 100		170	175	182	194	213	219	245	215	218	225	237
2 150		177	183	190	202	222	229	255	224	227	235	247...
2 200		185	190	198	211	231	238	266	234	237	245	257
2 250		193	198	206	220	241	248	277	243	246	255	268
2 300		200	206	215	228	250	258	288	253	256	265	279
2 350		208	214	223	237	260	268	299	263	266	275	290
2 400		216	223	232	247	270	279	311	273	277	286	301
2 450		224	231	241	256	281	289	323	284	287	297	312
2 500		233	239	250	265	291	300	335	294	298	308	324
2 550		241	248	259	275	302	311	347	305	309	319	335
2 600		250	257	268	285	312	322	359	316	320	330	347
2 650		259	266	277	295	323	333	372	327	331	342	360
2 700		267	275	287	305	334	344	384	338	342	354	372
2 750		276	284	296	315	346	356	397	349	354	366	384
2 800		285	294	306	325	357	368	410	361	365	378	397
2 850		295	303	316	336	368	380	424	372	377	390	410

l/min x 0.264 = gal/min

TABLE OF COEFFICIENTS N_2 (continued)
Calculation of pressure losses in drill pipes $p_{int} = N_2 B$ (kPa/100 m)

Nominal pipe size (in)	4 1/2										
	20										
Nominal weight (lb/ft)	16.6										
Pipe inside diameter (in)	3.826										
Tool joint inside diameter (in)	3.64										
	3 3/4	3 1/2	3 1/4	3	2 3/4	2 11/16	2 1/2	3 5/8	3 1/2	3 1/4	3
2 900	304	313	326	347	380	392	437	384	389	402	423
2 950	314	323	336	357	392	404	451	396	401	415	436
3 000	323	332	347	368	404	416	465	408	413	428	449
3 050	333	343	357	380	416	429	479	421	426	440	463
3 100	343	353	368	391	429	442	493	433	439	453	477
3 150	353	363	378	402	441	455	507	446	451	467	491
3 200	363	373	389	414	454	468	522	459	464	480	505
3 250	373	384	400	426	467	481	537	472	478	494	519
3 300	384	395	411	437	480	494	552	485	491	508	534
3 350	394	406	423	449	493	508	567	498	504	521	548
3 400	405	417	434	462	506	522	582	512	518	536	563
3 450	416	428	446	474	520	535	598	525	532	550	578
3 500	427	439	457	486	533	549	613	539	546	564	593
3 550	438	450	469	499	547	564	629	553	560	579	609
3 600	449	462	481	512	561	578	645	567	574	594	624
3 650	460	473	493	524	575	593	661	581	589	608	640
3 700	471	485	505	537	589	607	678	596	603	624	656
3 750	483	497	518	551	604	622	694	610	618	639	672
3 800	495	509	530	564	618	637	711	625	633	654	688
3 850	506	521	543	577	633	652	728	640	648	670	704
3 900	518	533	556	591	648	668	745	655	663	686	721
3 950	530	546	569	605	663	683	763	670	678	701	737
4 000	543	558	582	618	678	699	780	685	694	718	754
4 050	555	571	595	632	694	715	798	701	710	734	771
4 100	567	583	608	647	709	730	815	717	726	750	789
4 150	580	596	621	661	725	747	833	732	742	767	806
4 200	592	609	635	675	741	763	852	748	758	783	824
4 250	605	622	649	690	756	779	870	764	774	800	841

l/min x 0.264 = gal/min

TABLE OF COEFFICIENTS N_2 (continued)
Calculation of pressure losses in drill pipes $p_{int} = N_2 B$ (kPa/100 m)

Nominal pipe size (in)	5									
	19.5					25.5				
	4									
Pipe inside diameter (in)	4.276					4				
Tool joint inside diameter (in)	3 3/4	3 1/2	3 1/4	2 3/4	3 1/2	3 1/4	2 3/4	3 1/2	3 1/4	2 3/4
500	8	8	9	11	11	11	11	11	11	12
550	9	10	11	13	13	13	13	13	14	15
600	11	12	12	15	15	15	15	15	16	17
650	13	13	14	18	18	18	18	18	18	20
700	15	15	16	20	20	20	20	20	21	23
750	16	17	18	23	23	23	23	23	24	26
800	18	19	21	26	26	26	26	26	27	29
850	21	22	23	29	29	29	29	29	30	32
900	23	24	25	32	32	32	32	32	33	36
950	25	26	28	35	35	35	35	35	36	40
1 000	28	29	31	39	39	39	39	39	40	44
1 050	30	32	34	42	42	42	42	42	44	48
1 100	33	34	37	46	46	46	46	46	47	52
1 150	35	37	40	50	50	50	50	50	51	57
1 200	38	40	43	54	54	54	54	54	56	62
1 250	41	43	46	58	58	58	58	58	60	67
1 300	44	46	49	62	62	62	62	62	64	72
1 350	47	50	53	67	67	67	67	67	69	77
1 400	51	53	56	71	71	71	71	71	73	82
1 450	54	56	60	76	76	76	76	76	78	88
1 500	57	60	64	80	80	80	80	80	83	94
1 550	61	64	68	85	85	85	85	85	88	100
1 600	64	67	72	90	90	90	90	90	93	106
1 650	68	71	76	96	96	96	96	96	98	112
1 700	72	75	80	101	101	101	101	101	104	118
1 750	76	79	84	106	106	106	106	106	110	125
1 800	79	83	89	112	112	112	112	112	115	131
1 850	83	87	93	117	117	117	117	117	121	138
1 900	88	92	98	123	123	123	123	123	127	145
1 950	92	96	102	129	129	129	129	129	133	152
2 000	96	101	107	135	135	135	135	135	139	160
2 050	100	105	112	141	141	141	141	141	146	167
2 100	105	110	117	147	147	147	147	147	152	175
2 150	109	114	122	154	154	154	154	154	159	182
2 200	114	119	127	160	160	160	160	160	165	190
										178
										198

l/min x 0.264 = gal/min

TABLE OF COEFFICIENTS N_2 (continued)
Calculation of pressure losses in drill pipes $p_{int} = N_2 B$ (kPa/100 m)

Nominal pipe size (in)	5							
	25.5							
Nominal weight (lb/ft)	19.5							
Pipe inside diameter (in)	4.276							
Tool joint inside diameter (in)	3 3/4	3 1/2	3 1/4	2 3/4	3 1/2	3 1/4	3	2 3/4
2 250	119	124	133	167	164	172	185	206
2 300	124	134	138	174	170	179	193	215
2 350	128	134	143	181	177	186	200	223
2 400	133	140	149	187	184	193	208	232
2 450	138	145	155	195	191	201	216	241
2 500	144	150	160	202	198	208	224	250
2 550	149	156	166	209	205	216	232	259
2 600	154	161	172	217	212	223	240	268
2 650	159	167	178	224	220	231	249	277
2 700	165	173	184	232	227	239	257	287
2 750	170	178	190	240	235	247	266	296
2 800	176	184	197	247	243	255	275	306
2 850	182	190	203	255	251	263	283	316
2 900	188	196	209	264	259	272	292	326
2 950	193	202	216	272	267	280	302	336
3 000	199	209	223	280	275	289	311	347
3 050	205	215	229	289	283	298	320	357
3 100	211	221	236	297	292	306	330	368
3 150	218	228	243	306	300	315	339	378
3 200	224	234	250	315	309	325	349	389
3 250	230	241	257	324	317	334	359	400
3 300	237	248	264	333	326	343	369	411
3 350	243	254	271	342	335	352	379	423
3 400	250	261	279	351	344	362	389	434
3 450	256	268	286	360	354	372	400	446
3 500	263	275	294	370	363	381	410	457
3 550	270	282	301	379	372	391	421	469
3 600	277	290	309	389	382	401	432	481
3 650	284	297	317	399	391	411	442	493
3 700	291	304	325	409	401	421	453	505
3 750	298	312	333	419	411	432	465	518
3 800	305	319	341	429	421	442	476	530
3 850	312	327	349	439	431	453	487	543
3 900	320	334	357	449	441	463	498	556
3 950	327	342	365	460	451	474	510	569
4 000	334	350	374	470	461	485	522	582

l/min x 0.264 = gal/min

TABLE OF COEFFICIENTS N_2 (continued)
Calculation of pressure losses in drill pipes $p_{int} = N_2 B$ (kPa/100 m)

Nominal pipe size (in)	5 1/2						6 5/8									
	21.9			24.7			25.2			27.72						
	4.778						5.965									
Nominal weight (lb/ft)																
Pipe inside diameter (in)	4						5									
Tool joint inside diameter (in)	3 3/4		3 1/2		3		4		3 1/2		3		4 3/4		4 1/4	
	1 000	17	18	19	24	18	20	25	6	6	7	7	6	6	7	7
1 050	18	19	21	26	20	22	28	6	6	7	7	6	6	7	7	6
1 100	20	21	22	28	22	24	30	7	7	7	8	7	7	7	7	7
1 150	21	23	24	31	24	26	33	7	7	8	9	8	8	8	8	8
1 200	23	24	26	33	25	28	35	8	8	8	9	8	8	8	8	8
1 250	25	26	28	36	27	31	38	9	9	9	10	9	9	9	9	9
1 300	27	28	30	38	29	33	41	9	9	10	11	10	10	10	10	10
1 350	29	30	32	41	31	35	44	10	10	10	12	10	10	10	11	11
1 400	31	32	34	44	34	38	47	11	11	11	13	11	11	11	12	12
1 450	33	34	37	46	36	40	50	11	11	12	14	11	12	12	13	13
1 500	35	36	39	49	38	42	53	12	12	12	15	12	12	12	13	14
1 550	37	39	41	52	40	45	56	13	13	13	16	13	13	13	14	15
1 600	39	41	44	55	43	48	59	13	13	14	17	13	14	14	15	16
1 650	41	43	46	59	45	50	63	14	14	15	18	14	15	15	16	17
1 700	43	46	49	62	48	53	66	15	15	16	19	15	16	16	17	18
1 750	46	48	52	65	50	56	70	16	16	17	20	16	17	17	18	19
1 800	48	51	54	69	53	59	73	17	17	17	21	17	18	18	19	20
1 850	50	53	57	72	55	62	77	17	17	18	22	17	18	18	19	20
1 900	53	56	60	76	58	65	81	18	18	18	23	18	19	19	20	21
1 950	55	58	63	79	61	68	85	19	19	19	24	19	20	20	21	22
2 000	58	61	66	83	64	71	89	20	20	20	25	20	21	21	22	23
2 050	61	64	69	87	67	75	93	21	21	21	26	21	22	22	23	24
2 100	63	67	72	90	70	78	97	22	22	22	27	22	23	23	24	25
2 150	66	70	75	94	73	81	101	23	23	23	28	23	24	24	25	26
2 200	69	73	78	98	76	85	105	24	24	24	29	24	25	25	26	27
2 250	72	75	81	102	79	88	110	25	25	25	30	25	26	26	27	28
2 300	75	79	84	107	82	92	114	26	26	26	31	26	27	27	28	29
2 350	78	82	88	111	85	95	118	27	27	27	32	27	28	28	29	30
2 400	81	85	91	115	89	99	123	28	28	28	33	28	29	29	30	31
2 450	84	88	94	119	92	103	128	29	29	29	34	29	30	30	31	32
2 500	87	91	98	124	95	107	132	30	30	30	35	30	31	31	32	33
2 550	90	95	101	128	99	110	137	31	31	31	36	31	32	32	33	34
2 600	93	98	105	133	102	114	142	32	32	32	37	32	33	33	34	35
2 650	96	101	109	138	106	118	147	33	33	33	38	33	34	34	35	36
2 700	100	105	112	142	110	122	152	34	34	34	39	34	35	35	36	37
2 750	103	108	116	147	113	126	157	35	35	35	40	35	36	36	37	38

l/min x 0.264 = gal/min

TABLE OF COEFFICIENTS N_2 (continued)
Calculation of pressure losses in drill pipes $p_{int} = N_2 B$ (kPa/100 m)

Nominal pipe size (in)	5 1/2										6 5/8								
	21.9					24.7					25.2		27.72						
	4.778										5.965		5.901						
Tool joint inside diameter (in)	4		3 3/4		3 1/2		4		3 1/2		3		5		4 3/4		4 1/4		
	4	106	112	116	120	124	128	132	136	140	144	148	152	157	162	167	172	177	182
2 800	106	112	116	120	124	128	132	136	140	144	148	152	157	162	167	172	177	182	188
2 850	110	116	119	123	127	131	134	138	142	146	150	155	161	166	171	176	181	186	191
2 900	113	119	123	127	131	134	138	142	146	150	155	161	166	171	176	181	186	191	196
2 950	117	123	127	131	136	140	144	148	153	157	161	166	171	176	181	186	191	196	201
3 000	120	127	131	136	140	144	148	153	157	161	166	171	176	181	186	191	196	201	207
3 050	124	131	134	138	142	146	150	155	161	166	171	176	181	186	191	196	201	207	212
3 100	128	134	138	142	146	150	155	161	166	171	176	181	186	191	196	201	207	212	218
3 150	131	138	142	146	150	155	161	166	171	176	181	186	191	196	201	207	212	218	224
3 200	135	142	146	150	155	161	166	171	176	181	186	191	196	201	207	212	218	224	230
3 250	139	146	150	155	161	166	171	176	181	186	191	196	201	207	212	218	224	230	236
3 300	143	150	155	161	166	171	176	181	186	191	196	201	207	212	218	224	230	236	243
3 350	147	155	161	166	171	176	181	186	191	196	201	207	212	218	224	230	236	243	249
3 400	151	159	163	167	171	176	181	186	191	196	201	207	212	218	224	230	236	243	250
3 450	155	163	167	171	176	181	186	191	196	201	207	212	218	224	230	236	243	250	255
3 500	159	167	171	176	181	186	191	196	201	207	212	218	224	230	236	243	250	255	262
3 550	163	172	176	181	186	191	196	201	207	212	218	224	230	236	243	250	255	262	268
3 600	167	176	180	184	189	194	199	203	208	213	218	223	228	233	238	243	248	253	259
3 650	171	180	185	189	194	199	203	208	213	218	223	228	233	238	243	248	253	259	265
3 700	176	185	189	194	199	203	208	213	218	223	228	233	238	243	248	253	259	265	271
3 750	180	189	194	199	203	208	213	218	223	228	233	238	243	248	253	259	265	271	275
3 800	184	194	199	203	208	213	218	223	228	233	238	243	248	253	259	265	271	275	281
3 850	189	199	203	208	213	218	223	228	233	238	243	248	253	259	265	271	275	281	288
3 900	193	203	208	213	218	223	228	233	238	243	248	253	259	265	271	275	281	288	295
3 950	198	208	213	218	223	228	233	238	243	248	253	259	265	271	275	281	288	295	302
4 000	202	213	217	222	227	232	237	242	247	252	257	262	267	272	277	282	287	292	300
4 050	207	217	222	227	232	237	242	247	252	257	262	267	272	277	282	287	292	297	305
4 100	211	222	227	232	237	242	247	252	257	262	267	272	277	282	287	292	297	302	310
4 150	216	227	232	237	242	247	252	257	262	267	272	277	282	287	292	297	302	307	315
4 200	221	232	237	242	247	252	257	262	267	272	277	282	287	292	297	302	307	312	320
4 250	225	237	242	247	252	257	262	267	272	277	282	287	292	297	302	307	312	317	325
4 300	230	242	247	252	257	262	267	272	277	282	287	292	297	302	307	312	317	322	330
4 350	235	247	252	257	262	267	272	277	282	287	292	297	302	307	312	317	322	327	335
4 400	240	252	257	262	267	272	277	282	287	292	297	302	307	312	317	322	327	332	340
4 450	245	258	263	268	273	278	283	288	293	298	303	308	313	318	323	328	333	338	346
4 500	250	263	268	273	278	283	288	293	298	303	308	313	318	323	328	333	338	343	351
4 550	255	268	273	278	283	288	293	298	303	308	313	318	323	328	333	338	343	348	356

l/min x 0.264 = gal/min

TABLE OF COEFFICIENTS N_2 (continued)
Calculation of pressure losses in drill pipes $p_{int} = N_2 B$ (kPa/100 m)

Nominal pipe size (in)	5 1/2										6 5/8				
	21.9					24.7					25.2		27.72		
	3 3/4		3 1/2		3	4	3 1/2	4.67		5.965		5.901			
Pipe inside diameter (in)	4	3 3/4	3 1/2	3	4	3 1/2	3	4	3	5	4 3/4	4 1/4	5	4 3/4	4 1/4
Tool joint inside diameter (in)	4	3 3/4	3 1/2	3	4	3 1/2	3	4	3	5	4 3/4	4 1/4	5	4 3/4	4 1/4
4 600	260	274	293	371	286	319	397	286	319	397	93	105	94	97	109
4 650	265	279	299	378	291	326	405	291	326	405	95	107	95	99	111
4 700	270	284	305	386	297	332	413	297	332	413	97	109	97	101	113
4 750	275	290	311	393	303	338	421	303	338	421	99	111	99	103	115
4 800	281	295	317	401	309	345	429	309	345	429	101	113	101	105	117
4 850	286	301	323	408	314	351	437	314	351	437	102	115	103	107	120
4 900	291	306	329	416	320	358	445	320	358	445	104	117	105	109	122
4 950	297	312	335	423	326	364	453	326	364	453	106	119	107	111	124
5 000	302	318	341	431	332	371	461	332	371	461	108	122	109	113	126
5 050	308	324	347	439	338	378	470	338	378	470	110	124	111	115	129
5 100	313	329	353	447	344	384	478	344	384	478	112	126	113	117	131
5 150	319	335	360	455	350	391	486	350	391	486	114	128	115	119	133
5 200	324	341	366	463	356	398	495	356	398	495	116	130	117	121	136
5 250	330	347	372	471	363	405	504	363	405	504	118	133	119	123	138
5 300	335	353	379	479	369	412	512	369	412	512	120	135	121	125	140
5 350	341	359	385	487	375	419	521	375	419	521	122	137	123	128	143
5 400	347	365	392	495	381	426	530	381	426	530	124	140	125	130	145
5 450	353	371	398	504	388	433	539	388	433	539	126	142	127	132	148
5 500	359	377	405	512	394	440	548	394	440	548	128	144	129	134	150
5 550	364	383	411	520	401	448	557	401	448	557	131	147	131	136	152
5 600	370	390	418	529	407	455	566	407	455	566	128	149	133	138	155
5 650	376	396	425	537	414	462	575	414	462	575	130	152	136	141	157
5 700	382	402	432	546	420	470	584	420	470	584	132	154	138	143	160
5 750	388	409	439	555	427	477	593	427	477	593	134	156	140	145	162
5 800	395	415	445	563	434	485	602	434	485	602	141	159	142	147	165
5 850	401	422	452	572	440	492	612	440	492	612	144	161	144	150	168
5 900	407	428	459	581	447	500	621	447	500	621	146	164	147	152	170
5 950	413	435	466	590	454	507	631	454	507	631	148	166	149	154	173
6 000	419	441	473	599	461	515	640	461	515	640	150	169	151	157	175
6 050	426	448	481	608	468	523	650	468	523	650	152	171	153	159	178
6 100	432	455	488	617	475	531	660	475	531	660	155	174	156	162	181
6 150	438	461	495	626	482	539	669	482	539	669	157	176	158	164	183
6 200	445	468	502	635	489	546	679	489	546	679	159	179	160	166	186
6 250	451	475	510	644	496	554	689	496	554	689	162	182	163	169	189
6 300	458	482	517	654	503	562	699	503	562	699	164	184	165	171	191
6 350	464	489	524	663	511	570	709	511	570	709	166	187	167	174	194

l/min x 0.264 = gal/min

TABLE OF COEFFICIENTS N_3
Calculation of pressure losses in drill collars $p_{int} = N_3 B$ (kPa/100 m)

Drill collar ID	1 1/2		1 3/4		2		2 1/4		2 1/2		2 3/4		2 13/16		3		3 1/4		3 1/2	
	(in)	(mm)																		
100	63	38.10	30	44.45	50.80	57.15	63.50	69.85	71.44	76.20	82.55	88.90								
150	131		62		33	19	11	7	3	5	2	1								
200	220		105		55	31	19	12	6	8	3	2								
250	328		157		82	47	28	18	11	12	5	3								
300	456		217		115	65	39	25	16	16	8	5								
350	601		287		151	86	52	33	22	22	11	8								
400	765		365		192	109	66	42	29	27	15	10								
450	945		451		238	135	81	52	37	34	19	13								
500	1 143		545		287	163	98	62	46	41	23	16								
550	1 356		647		341	194	117	74	56	41	28	20								
600	1 586		757		399	227	137	86	66	49	33	23								
650	1 832		874		461	262	158	100	78	57	39	27								
700	2 094		999		526	299	180	114	90	66	45	31								
750	2 371		1 131		596	339	204	129	102	75	51	36								
800	2 663		1 270		669	380	229	145	116	85	58	41								
850	2 970		1 417		746	424	256	162	130	96	65	46								
900	3 291		1 570		827	470	283	179	145	107	73	51								
950	3 628		1 731		912	518	312	198	161	118	80	56								
1 000	3 979		1 898		1 000	568	343	217	178	130	89	62								
1 050	4 344		2 073		1 092	620	374	237	195	143	97	68								
1 100	4 723		2 254		1 187	675	407	257	213	156	106	74								
1 150	5 117		2 441		1 286	731	441	279	231	170	115	81								
1 200	5 524		2 636		1 389	789	476	301	250	184	125	88								
1 250	5 945		2 837		1 494	849	512	324	270	198	135	95								
1 300	6 380		3 044		1 604	911	549	348	291	213	145	102								
1 350	6 829		3 258		1 716	975	588	372	312	229	156	109								
1 400	7 291		3 479		1 833	1 041	628	397	334	245	167	117								
1 450	7 766		3 706		1 952	1 109	669	423	357	262	178	125								
1 500	8 255		3 939		2 075	1 179	711	450	380	279	190	133								
1 550	8 757		4 178		2 201	1 251	754	477	404	296	202	141								
1 600	9 271		4 424		2 330	1 324	799	505	428	314	214	150								
1 650	9 800		4 676		2 463	1 399	844	534	454	333	227	159								
1 700	10 341		4 934		2 599	1 477	891	564	480	352	240	168								
1 750	10 894		5 198		2 738	1 556	938	594	506	371	253	177								
1 800	11 461		5 469		2 881	1 637	987	625	533	391	266	187								
1 850	12 040		5 745		3 026	1 720	1 037	656	561	411	280	196								
1 900	12 633		6 028		3 175	1 804	1 088	689	589	432	294	206								
1 950	13 237		6 316		3 327	1 890	1 140	722	618	453	309	216								
2 000	13 854		6 611		3 482	1 979	1 193	755	648	475	324	227								
2 050	14 484		6 911		3 641	2 068	1 247	789	678	497	339	237								
2 100	15 126		7 217		3 802	2 160	1 303	824	709	520	354	248								

l/min x 0.264 = gal/min

TABLE OF COEFFICIENTS N_3 (continued)
Calculation of pressure losses in drill collars $p_{int} = N_3 B$ (kPa/100 m)

Drill collar ID	1 1/2	1 3/4	2	2 1/4	2 1/2	2 3/4	2 13/16	3	3 1/4	3 1/2
	(in)									
	38.10	44.45	50.80	57.15	63.50	69.85	71.44	76.20	82.55	88.90
2 150	15 781	7 530	3 967	2 254	1 359	860	772	566	386	270
2 200	16 447	7 848	4 134	2 349	1 417	896	805	590	402	282
2 250	17 126	8 172	4 305	2 446	1 475	933	838	615	419	293
2 300	17 817	8 502	4 479	2 545	1 535	971	872	640	436	305
2 350	18 521	8 837	4 655	2 645	1 595	1 009	906	665	453	317
2 400	19 236	9 178	4 835	2 747	1 657	1 048	941	691	470	329
2 450	19 963	9 526	5 018	2 851	1 719	1 088	977	717	488	342
2 500	20 703	9 878	5 204	2 957	1 783	1 128	1 013	743	506	355
2 550	21 454	10 237	5 393	3 064	1 848	1 169	1 050	770	524	367
2 600	22 217	10 601	5 584	3 173	1 913	1 211	1 087	798	543	381
2 650	22 992	10 971	5 779	3 284	1 980	1 253	1 125	825	562	394
2 700	23 779	11 346	5 977	3 396	2 048	1 296	1 164	854	581	407
2 750	24 577	11 727	6 178	3 510	2 117	1 340	1 203	882	601	421
2 800	25 387	12 114	6 381	3 626	2 186	1 384	1 242	911	621	435
2 850	26 209	12 506	6 588	3 743	2 257	1 429	1 282	941	641	449
2 900	27 043	12 903	6 797	3 862	2 329	1 474	1 323	971	661	463
2 950	27 888	13 307	7 010	3 983	2 402	1 520	1 365	1 001	682	478
3 000	28 744	13 715	7 225	4 105	2 476	1 567	1 407	1 032	703	492
3 050	29 612	14 130	7 443	4 229	2 550	1 614	1 449	1 063	724	507
3 100	30 492	14 549	7 664	4 355	2 626	1 662	1 492	1 095	745	522
3 150	31 383	14 974	7 888	4 482	2 703	1 711	1 536	1 127	767	538
3 200	32 285	15 405	8 115	4 611	2 781	1 760	1 580	1 159	789	553
3 250	33 199	15 841	8 345	4 741	2 859	1 810	1 624	1 192	812	569
3 300	34 124	16 282	8 577	4 873	2 939	1 860	1 670	1 225	834	584
3 350	35 060	16 729	8 813	5 007	3 020	1 911	1 716	1 259	857	601
3 400	36 008	17 181	9 051	5 142	3 101	1 963	1 762	1 293	880	617
3 450	36 966	17 639	9 292	5 279	3 184	2 015	1 809	1 327	904	633
3 500	37 936	18 101	9 536	5 418	3 267	2 068	1 856	1 362	927	650
3 550	38 917	18 569	9 782	5 558	3 352	2 121	1 904	1 397	951	667
3 600	39 910	19 043	10 032	5 700	3 437	2 175	1 953	1 433	976	684
3 650	40 913	19 522	10 284	5 843	3 524	2 230	2 002	1 469	1 000	701
3 700	41 927	20 006	10 539	5 988	3 611	2 285	2 052	1 505	1 025	718
3 750	42 953	20 495	10 797	6 134	3 699	2 341	2 102	1 542	1 050	736
3 800	43 989	20 989	11 057	6 282	3 789	2 398	2 152	1 579	1 075	753
3 850	45 036	21 489	11 320	6 432	3 879	2 455	2 204	1 617	1 101	771
3 900	46 095	21 994	11 586	6 583	3 970	2 512	2 256	1 655	1 127	790
3 950	47 164	22 504	11 855	6 736	4 062	2 571	2 308	1 693	1 153	808
4 000	48 244	23 020	12 127	6 890	4 155	2 630	2 361	1 732	1 179	826
4 050	49 335	23 540	12 401	7 046	4 249	2 689	2 414	1 771	1 206	845
4 100	50 436	24 066	12 678	7 203	4 344	2 749	2 468	1 811	1 233	864
4 150	51 549	24 597	12 957	7 362	4 440	2 810	2 522	1 850	1 260	883

l/min x 0.264 = gal/min

CALCULATIONS OF PRESSURE DROP IN NOZZLES

Combination of three nozzles

$$P_d = \frac{dQ^2}{2959.41 \times (0.95)^2 A^2} \quad (\text{kPa}) \quad d = 1, \quad A = \text{nozzle area (in}^2)$$

Nozzles (1/32)	8-8-8	8-8-9	8-9-9	9-9-9	9-9-10	9-10-10	10-10-10	10-10-11	10-11-11	11-11-11	11-11-12	11-12-12
A (in ²)	0.1473	0.1603	0.1733	0.1864	0.201	0.2155	0.2301	0.2462	0.2623	0.2784	0.2961	0.3137
200	690	583	499	431	371	322	283	247	218	193	171	152
250	1 079	911	779	673	579	504	442	386	340	302	267	238
300	1 553	1 311	1 122	970	834	726	636	556	490	435	384	342
350	2 114	1 785	1 527	1 320	1 135	988	866	757	667	592	523	466
400	2 761	2 331	1 995	1 724	1 483	1 290	1 131	988	871	773	683	609
450	3 494	2 951	2 525	2 182	1 877	1 633	1 432	1 251	1 102	978	865	770
500	4 314	3 643	3 117	2 694	2 317	2 016	1 768	1 544	1 360	1 208	1 068	951
550	5 220	4 408	3 771	3 260	2 803	2 439	2 139	1 869	1 646	1 461	1 292	1 151
600	6 212	5 245	4 488	3 879	3 336	2 902	2 546	2 224	1 959	1 739	1 537	1 370
650	7 291	6 156	5 267	4 553	3 915	3 406	2 988	2 610	2 299	2 041	1 804	1 607
700	8 455	7 140	6 109	5 280	4 541	3 950	3 475	3 027	2 667	2 367	2 093	1 864
750	9 707	8 196	7 013	6 061	5 213	4 535	3 978	3 475	3 061	2 717	2 402	2 140
800	11 044	9 325	7 979	6 897	5 931	5 160	4 526	3 953	3 483	3 092	2 733	2 435
850	12 468	10 527	9 007	7 786	6 696	5 825	5 109	4 463	3 932	3 490	3 085	2 749
900	13 977	11 802	10 098	8 729	7 507	6 530	5 728	5 003	4 408	3 913	3 459	3 082
950	15 574	13 150	11 251	9 725	8 364	7 276	6 382	5 575	4 911	4 360	3 854	3 434
1 000		14 571	12 467	10 776	9 267	8 062	7 072	6 177	5 442	4 831	4 270	3 805
1 050		16 064	13 745	11 880	10 217	8 889	7 796	6 810	6 000	5 326	4 708	4 195
1 100			15 085	13 039	11 213	9 755	8 557	7 474	6 585	5 845	5 167	4 604
1 150				14 251	12 256	10 662	9 352	8 169	7 197	6 389	5 648	5 032
1 200				15 517	13 345	11 610	10 183	8 895	7 836	6 956	6 149	5 479
1 250					14 480	12 597	11 049	9 651	8 503	7 548	6 673	5 945
1 300					15 662	13 625	11 951	10 439	9 197	8 164	7 217	6 430
1 350						14 693	12 860	11 257	9 918	8 804	7 783	6 934
1 400						15 802	13 860	12 107	10 666	9 468	8 370	7 457
1 450							14 868	12 987	11 442	10 157	8 979	7 999
1 500							15 911	13 898	12 244	10 869	9 608	8 561
1 550								14 840	13 074	11 606	10 260	9 141
1 600								15 813	13 931	12 367	10 932	9 740
1 650									14 816	13 152	11 626	10 358
1 700									15 727	13 961	12 342	10 996
1 750										14 794	13 078	11 652
1 800										15 651	13 836	12 327
1 850											14 616	13 022
1 900											15 416	13 735
1 950												14 467
2 000												15 219

Flow rate
Q
(l/min)

l/min x 0.264 = gal/min kPa x 0.125 = psi kg/l = sp.gr kg/l x 8.35 = lb/gal

CALCULATIONS OF PRESSURE DROP IN NOZZLES (continued)

Combination of three nozzles

$$P_d = \frac{dQ^2}{2959.41 \times (0.95)^2 A^2} \quad (\text{kPa}) \quad d = 1, \quad A = \text{nozzle area (in}^2)$$

Nozzles (1/32)	12-12-12	12-12-13	12-13-13	13-13-13	13-13-14	13-14-14	14-14-14	14-14-15	14-15-15	15-15-15	15-15-16
A (in ²)	0.3313	0.3505	0.3697	0.3889	0.4096	0.4303	0.451	0.4732	0.4955	0.5177	0.5415
Flow rate Q (l/min)	136 213 307 418 546 691 853 1032 1228 1441 1671 1919 2183 2465 2763 3079 3411 3761 4128 4511 4912 5330 5765 6217 6686 7172 7675 8195 8733 9287 9858 10447 11052 11675 12314 12971 13645	122 190 274 373 488 617 762 922 1097 1288 1493 1714 1951 2202 2469 2751 3048 3360 3688 4031 4389 4762 5151 5554 5973 6408 6857 7322 7802 8297 8808 9334 9875 10431 11002 11589 12191	110 171 247 336 438 555 685 829 986 1157 1342 1541 1753 1979 2219 2472 2739 3020 3315 3623 3945 4280 4630 4992 5369 5759 6164 6581 7013 7458 7917 8389 8876 9375 9889 10416 10957	99 155 223 303 396 501 619 749 891 1046 1213 1392 1584 1789 2005 2234 2476 2729 2995 3274 3565 3868 4184 4512 4852 5205 5570 5948 6337 6740 7154 7581 8021 8473 8937 9413 9902	89 139 201 273 357 452 558 675 803 943 1094 1255 1428 1612 1808 2014 2232 2460 2700 2951 3214 3487 3772 4067 4374 4692 5021 5362 5713 6076 6449 6834 7231 7638 8056 8486 8927	81 126 182 248 324 409 506 612 728 854 991 1137 1294 1461 1638 1825 2022 2229 2447 2674 2912 3160 3417 3685 3963 4251 4550 4858 5177 5505 5844 6193 6552 6921 7300 7689 8088	74 115 166 225 295 373 460 557 663 778 902 1035 1178 1330 1491 1661 1841 2029 2227 2434 2651 2876 3111 3355 3608 3870 4142 4422 4712 5011 5320 5637 5964 6300 6645 6999 7363	67 105 150 205 268 339 418 506 602 706 819 941 1070 1208 1364 1509 1672 1843 2023 2211 2408 2613 2826 3047 3277 3516 3762 4017 4281 4552 4832 5121 5418 5723 6036 6358 6688	61 95 137 187 244 309 381 461 549 644 747 858 976 1102 1235 1376 1525 1681 1845 2017 2196 2383 2577 2779 2989 3206 3431 3664 3904 4152 4407 4670 4941 5219 5505 5799 6100	56 87 126 171 224 283 349 423 503 590 685 786 894 1009 1132 1261 1397 1540 1690 1848 2012 2183 2361 2546 2738 2937 3143 3356 3576 3803 4037 4278 4526 4781 5043 5312 5588	51 80 115 156 204 259 319 386 460 539 626 718 817 923 1034 1152 1277 1408 1545 1689 1839 1995 2158 2327 2503 2685 2873 3068 3269 3476 3690 3910 4137 4370 4610 4855 5108

l/min x 0.264 = gal/min kPa x 0.125 = psi kg/l = sp.gr kg/l x 8.35 = lb/gal

CALCULATIONS OF PRESSURE DROP IN NOZZLES (continued)

Combination of three nozzles

$$P_d = \frac{dQ^2}{2959.41 \times (0.95)^2 A^2} \text{ (kPa)} \quad d = 1, \quad A = \text{nozzle area (in}^2\text{)}$$

Nozzles (1/32)	12-12-12	12-12-13	12-13-13	13-13-13	13-13-14	13-14-14	14-14-14	14-14-15	14-15-15	15-15-15	15-15-16
A (in ²)	0.3313	0.3505	0.3697	0.3889	0.4096	0.4303	0.451	0.4732	0.4955	0.5177	0.5415
Flow rate Q (l/min)	14 335 15 768 16 510 17 269 18 045 18 838 19 648 20 476 21 320	12 808 14 088 14 751 15 429 16 122 16 831 17 555 18 294 19 048 19 818 20 602 21 402	11 512 12 663 13 258 13 868 14 491 15 128 15 779 16 443 17 121 17 813 18 518 19 237 19 970 20 716 21 477	10 404 11 443 11 982 12 532 13 096 13 671 14 259 14 859 15 472 16 097 16 735 17 385 18 047 18 721 19 408 20 108 20 819 21 543	9 379 10 316 10 801 11 298 11 805 12 324 12 854 13 396 13 948 14 511 15 086 15 672 16 269 16 877 17 496 18 127 18 768 19 421 20 085 20 760 21 446	8 498 9 347 9 787 10 237 10 697 11 167 11 647 12 138 12 638 13 149 13 669 14 200 14 741 15 292 15 853 16 425 17 006 17 597 18 199 18 811 19 432 20 064 20 706 21 359	7 736 8 509 8 909 9 319 9 738 10 166 10 603 11 049 11 505 11 969 12 443 12 927 13 419 13 921 14 431 14 951 15 481 16 019 16 567 17 124 17 690 18 265 18 849 19 443 20 046 20 658 21 279 21 910	7 027 7 729 8 093 8 465 8 845 9 234 9 631 10 037 10 451 10 873 11 303 11 742 12 189 12 645 13 109 13 582 14 062 14 551 15 049 15 555 16 069 16 591 17 122 17 661 18 209 18 765 19 329 19 902 20 483 21 072	6 409 7 049 7 381 7 720 8 067 8 422 8 784 9 154 9 531 9 916 10 309 10 709 11 117 11 533 11 956 12 387 12 825 13 271 13 725 14 186 14 655 15 131 15 616 16 107 16 607 17 114 17 629 18 151 18 681 19 218 19 764 20 316 20 877	5 871 6 458 6 761 7 072 7 390 7 715 8 047 8 385 8 731 9 084 9 444 9 810 10 184 10 565 10 952 11 347 11 749 12 157 12 573 12 995 13 425 13 862 14 305 14 756 15 213 15 678 16 149 16 628 17 113 17 605 18 105 18 611 19 125 19 645 20 172	5 366 5 902 6 180 6 464 6 755 7 052 7 355 7 664 7 981 8 303 8 632 8 967 9 308 9 656 10 011 10 371 10 739 11 112 11 492 11 878 12 271 12 670 13 075 13 487 13 905 14 330 14 761 15 198 15 642 16 092 16 548 17 011 17 481 17 956 18 438 18 927 19 421 19 923

l/min x 0.264 = gal/min kPa x 0.125 = psi kg/l = sp.gr kg/l x 8.35 = lb/gal

CALCULATIONS OF PRESSURE DROP IN NOZZLES (continued)

Combination of three nozzles

$$P_d = \frac{dQ^2}{2 \cdot 959.41 \times (0.95)^2 \cdot A^2} \quad (\text{kPa}) \quad d = 1, \quad A = \text{nozzle area (in}^2)$$

Nozzles (1/32)	15-16-16	16-16-16	16-16-18	16-18-18	18-18-18	20-20-20	20-20-22	20-22-22	22-22-22	24-24-24	32-32-32
A (in ²)	0.5653	0.589	0.6412	0.6934	0.7455	0.9204	0.9848	1.0492	1.1137	1.3254	2.3562
500	293	270	228	195	168	110	97	85	75	53	17
550	354	326	275	236	204	134	117	103	91	64	20
600	422	389	328	280	243	159	139	122	109	77	24
650	495	456	385	329	285	187	163	144	128	90	28
700	574	529	446	382	330	217	189	167	148	104	33
750	659	607	512	438	379	249	217	191	170	120	38
800	750	691	583	498	431	283	247	218	193	136	43
850	847	780	658	563	487	319	279	246	218	154	49
900	949	874	738	631	546	368	313	275	245	173	55
950	1 057	974	822	703	608	399	348	307	272	192	61
1 000	1 172	1 079	911	779	674	442	386	340	302	213	67
1 050	1 292	1 190	1 004	859	743	487	426	375	333	235	74
1 100	1 418	1 306	1 102	942	815	535	467	412	365	258	82
1 150	1 549	1 427	1 204	1 030	891	585	511	450	399	282	89
1 200	1 687	1 554	1 311	1 121	970	636	556	490	435	307	97
1 250	1 831	1 686	1 423	1 217	1 053	691	603	531	472	333	105
1 300	1 980	1 824	1 539	1 316	1 139	747	652	575	510	360	114
1 350	2 135	1 967	1 660	1 419	1 228	805	704	620	550	388	123
1 400	2 296	2 115	1 785	1 526	1 320	866	757	667	592	418	132
1 450	2 463	2 269	1 915	1 637	1 416	929	812	715	635	448	142
1 500	2 636	2 428	2 049	1 752	1 516	994	869	765	679	480	152
1 550	2 815	2 593	2 188	1 871	1 619	1 062	928	817	725	512	162
1 600	2 999	2 763	2 331	1 994	1 725	1 131	988	871	773	546	173
1 650	3 190	2 938	2 479	2 120	1 834	1 203	1 051	926	822	580	184
1 700	3 386	3 119	2 632	2 250	1 947	1 277	1 116	983	872	616	195
1 750	3 588	3 305	2 789	2 385	2 063	1 354	1 182	1 042	924	653	207
1 800	3 796	3 497	2 951	2 523	2 183	1 432	1 251	1 102	978	691	219

l/min x 0.264 = gal/min kPa x 0.125 = psi kg/l = sp.gr kg/l x 8.35 = lb/gal

CALCULATIONS OF PRESSURE DROP IN NOZZLES (continued)

Combination of three nozzles

$$P_d = \frac{dQ^2}{2959.41 \times (0.95)^2 A^2} \quad (\text{kPa}) \quad d = 1, \quad A = \text{nozzle area (in}^2)$$

Nozzles (1/32)	15-16-16	16-16-16	16-16-18	16-18-18	18-18-18	20-20-20	20-20-22	20-22-22	22-22-22	24-24-24	32-32-32
A (in ²)	0.5653	0.589	0.6412	0.6934	0.7455	0.9204	0.9848	1.0492	1.1137	1.3254	2.3562
1 850	4 010	3 694	3 117	2 665	2 306	1 513	1 321	1 164	1 033	729	231
1 900	4 230	3 896	3 288	2 811	2 432	1 596	1 394	1 228	1 090	769	243
1 950	4 455	4 104	3 463	2 961	2 562	1 681	1 468	1 293	1 148	810	256
2 000	4 687	4 317	3 643	3 115	2 695	1 768	1 544	1 360	1 207	853	270
2 050	4 924	4 535	3 827	3 273	2 831	1 857	1 622	1 429	1 269	896	283
2 100	5 167	4 759	4 016	3 434	2 971	1 949	1 703	1 500	1 331	940	297
2 150	5 416	4 989	4 210	3 600	3 114	2 043	1 785	1 572	1 395	985	312
2 200	5 671	5 224	4 408	3 769	3 261	2 139	1 869	1 646	1 461	1 032	326
2 250	5 931	5 464	4 610	3 942	3 410	2 237	1 954	1 722	1 528	1 079	341
2 300	6 198	5 709	4 817	4 119	3 564	2 338	2 042	1 799	1 597	1 127	357
2 350	6 470	5 960	5 029	4 300	3 720	2 441	2 132	1 878	1 667	1 177	372
2 400	6 749	6 216	5 245	4 485	3 880	2 546	2 224	1 959	1 739	1 228	388
2 450	7 033	6 478	5 466	4 674	4 044	2 653	2 317	2 042	1 812	1 279	405
2 500	7 323	6 745	5 692	4 867	4 210	2 762	2 413	2 126	1 887	1 332	422
2 550	7 619	7 018	5 922	5 064	4 381	2 874	2 510	2 212	1 963	1 386	439
2 600	7 920	7 296	6 156	5 264	4 554	2 988	2 610	2 299	2 041	1 441	456
2 650	8 228	7 579	6 395	5 469	4 731	3 104	2 711	2 388	2 120	1 497	474
2 700	8 541	7 868	6 639	5 677	4 911	3 222	2 814	2 479	2 201	1 554	492
2 750	8 860	8 162	6 887	5 889	5 095	3 342	2 920	2 572	2 283	1 612	510
2 800	9 186	8 461	7 140	6 105	5 282	3 465	3 027	2 667	2 367	1 671	529
2 850	9 517	8 766	7 397	6 325	5 472	3 590	3 136	2 763	2 452	1 731	548
2 900	9 853	9 076	7 659	6 549	5 666	3 717	3 247	2 860	2 539	1 792	567
2 950	10 196	9 392	7 925	6 777	5 863	3 846	3 360	2 960	2 627	1 855	587
3 000	10 545	9 713	8 196	7 008	6 063	3 978	3 475	3 061	2 717	1 918	607
3 050	10 899	10 040	8 471	7 244	6 267	4 111	3 591	3 164	2 808	1 983	627
3 100	11 259	10 371	8 752	7 483	6 474	4 247	3 710	3 269	2 901	2 048	648
3 150	11 625	10 709	9 036	7 727	6 685	4 385	3 831	3 375	2 995	2 115	669

l/min x 0.264 = gal/min kPa x 0.125 = psi kg/l = sp.gr kg/l x 8.35 = lb/gal

CALCULATIONS OF PRESSURE DROP IN NOZZLES (continued)

Combination of three nozzles

$$p_d = \frac{dQ^2}{2 \cdot 959.41 \times (0.95)^2 \cdot A^2} \quad (\text{kPa}) \quad d = 1, \quad A = \text{nozzle area (in}^2\text{)}$$

Nozzles (1/32)	15-16-16	16-16-16	16-16-18	16-18-18	18-18-18	20-20-20	20-20-22	20-22-22	22-22-22	24-24-24	32-32-32
A (in ²)	0.5653	0.589	0.6412	0.6934	0.7455	0.9204	0.9848	1.0492	1.1137	1.3254	2.3562
Flow rate Q (l/min)	11 997 12 375 12 759 13 149 13 544 13 945 14 352 14 765 15 184 15 609 16 040 16 476 16 918 17 366 17 820 18 280 18 746 19 218 19 695	11 051 11 399 11 753 12 112 12 476 12 846 13 221 13 601 13 987 14 378 14 775 15 177 15 584 15 997 16 415 16 839 17 268 17 702 18 142 18 587 19 038 19 494 19 955	9 325 9 619 9 917 10 220 10 527 10 839 11 156 11 477 11 802 12 132 12 467 12 806 13 150 13 498 13 851 14 209 14 571 14 937 15 308 15 684 16 064 16 449 16 838 17 232 17 631 18 034 18 441	7 974 8 225 8 480 8 739 9 002 9 269 9 539 9 814 10 092 10 374 10 661 10 951 11 245 11 543 11 844 12 150 12 459 12 773 13 090 13 411 13 737 14 066 14 398 14 735 15 076 15 421 15 769	6 898 7 116 7 336 7 560 7 788 8 018 8 253 8 490 8 731 8 975 9 223 9 474 9 728 9 986 10 247 10 511 10 779 11 050 11 325 11 602 11 884 12 168 12 456 12 748 13 042 13 341 13 642	4 526 4 668 4 813 4 960 5 109 5 261 5 414 5 570 5 728 5 888 6 051 6 215 6 382 6 551 6 722 6 896 7 072 7 249 7 430 7 612 7 796 7 983 8 172 8 363 8 557 8 752 8 950	3 953 4 078 4 204 4 333 4 463 4 595 4 729 4 865 5 003 5 143 5 285 5 429 5 575 5 722 5 872 6 023 6 177 6 332 6 490 6 649 6 810 6 973 7 138 7 305 7 474 7 645 7 818	3 483 3 593 3 704 3 817 3 932 4 048 4 166 4 286 4 408 4 531 4 656 4 783 4 911 5 041 5 173 5 307 5 442 5 579 5 717 5 858 6 000 6 143 6 289 6 436 6 585 6 735 6 887	3 091 3 188 3 287 3 388 3 490 3 593 3 698 3 804 3 912 4 022 4 133 4 245 4 359 4 474 4 591 4 710 4 830 4 951 5 074 5 199 5 325 5 452 5 581 5 712 5 844 5 978 6 113	2 182 2 251 2 321 2 392 2 464 2 537 2 611 2 686 2 762 2 839 2 918 2 997 3 078 3 159 3 242 3 325 3 410 3 496 3 583 3 671 3 760 3 850 3 941 4 033 4 126 4 221 4 316	691 712 734 757 780 803 826 850 874 898 923 948 974 1 000 1 026 1 052 1 079 1 106 1 134 1 162 1 190 1 218 1 247 1 276 1 306 1 335 1 366

l/min x 0.264 = gal/min kPa x 0.125 = psi kg/l = sp.gr kg/l x 8.35 = lb/gal

CALCULATIONS OF PRESSURE DROP IN NOZZLES

Combination of two nozzles

$$P_d = \frac{d\Omega^2}{2959.41 \times (0.95)^2 A^2} \quad (\text{kPa}) \quad d = 1, \quad A = \text{nozzle area (in}^2\text{)}$$

Nozzles (1/32)	11-11	12-12	13-13	14-14	15-15	16-16	18-18	20-20	22-22	24-24	32-32
A (in ²)	0.1856	0.2209	0.2592	0.3007	0.3451	0.3927	0.497	0.6136	0.7424	0.8836	1.5708
500	2 717	1 918	1 393	1 035	786	607	379	249	170	120	38
550	3 288	2 321	1 686	1 253	951	734	459	301	205	145	46
600	3 913	2 762	2 006	1 491	1 132	874	546	358	245	173	55
650	4 592	3 242	2 355	1 749	1 328	1 026	640	420	287	203	64
700	5 326	3 760	2 731	2 029	1 540	1 190	743	487	333	235	74
750	6 114	4 316	3 135	2 329	1 768	1 366	853	559	382	270	85
800	6 956	4 911	3 567	2 650	2 012	1 554	970	636	435	307	97
850	7 853	5 544	4 026	2 992	2 271	1 754	1 095	718	491	346	110
900	8 804	6 215	4 514	3 354	2 546	1 967	1 228	805	550	388	123
950	9 809	6 925	5 030	3 737	2 837	2 191	1 368	897	613	433	137
1 000	10 869	7 673	5 573	4 141	3 144	2 428	1 516	994	679	480	152
1 050	11 983	8 459	6 144	4 565	3 466	2 677	1 671	1 096	749	529	167
1 100	13 152	9 284	6 743	5 010	3 804	2 938	1 834	1 203	822	580	184
1 150	14 374	10 147	7 370	5 476	4 158	3 211	2 005	1 315	898	634	201
1 200	15 651	11 049	8 025	5 963	4 527	3 496	2 183	1 432	978	691	219
1 250	16 983	11 989	8 708	6 470	4 912	3 794	2 368	1 554	1 061	749	237
1 300	18 369	12 967	9 418	6 998	5 313	4 103	2 562	1 681	1 148	810	256
1 350	19 809	13 984	10 157	7 547	5 730	4 425	2 763	1 812	1 238	874	277
1 400	21 303	15 039	10 923	8 116	6 162	4 759	2 971	1 949	1 331	940	297
1 450		16 132	11 717	8 706	6 610	5 105	3 187	2 091	1 428	1 008	319
1 500		17 264	12 539	9 317	7 074	5 463	3 410	2 237	1 528	1 079	341
1 550		18 434	13 389	9 948	7 553	5 833	3 642	2 389	1 632	1 152	365
1 600		19 642	14 267	10 600	8 048	6 215	3 880	2 546	1 739	1 228	388
1 650			15 172	11 273	8 559	6 610	4 127	2 707	1 849	1 306	413
1 700			16 106	11 967	9 086	7 017	4 381	2 874	1 963	1 386	439
1 750			17 067	12 681	9 628	7 435	4 642	3 045	2 080	1 469	465
1 800			18 056	13 416	10 186	7 866	4 911	3 222	2 201	1 554	492

l/min x 0.264 = gal/min kPa x 0.125 = psi kg/l = sp.gr kg/l x 8.35 = lb/gal

CALCULATIONS OF PRESSURE DROP IN NOZZLES (continued)

Combination of two nozzles

$$P_d = \frac{dQ^2}{2959.41 \times (0.95)^2 A^2} \text{ (kPa)} \quad d = 1, \quad A = \text{nozzle area (in}^2\text{)}$$

Nozzles (1/32)	11-11	12-12	13-13	14-14	15-15	16-16	18-18	20-20	22-22	24-24	32-32
A (in ²)	0.1856	0.2209	0.2592	0.3007	0.3451	0.3927	0.497	0.6136	0.7424	0.8836	1.5708
1 850			19 073	14 172	10 760	8 309	5 188	3 403	2 325	1 641	519
1 900			20 118	14 948	11 349	8 765	5 472	3 590	2 452	1 731	548
1 950				15 745	11 954	9 232	5 764	3 781	2 583	1 823	577
2 000				16 563	12 575	9 711	6 063	3 978	2 717	1 918	607
2 050				17 402	13 212	10 203	6 370	4 179	2 855	2 015	638
2 100				18 261	13 864	10 707	6 685	4 385	2 996	2 115	669
2 150				19 141	14 532	11 223	7 007	4 597	3 140	2 217	701
2 200				20 041	15 216	11 751	7 336	4 813	3 288	2 321	734
2 250					15 916	12 291	7 674	5 034	3 439	2 428	768
2 300					16 631	12 843	8 018	5 261	3 594	2 537	803
2 350					17 362	13 408	8 371	5 492	3 752	2 648	838
2 400					18 108	13 985	8 731	5 728	3 913	2 762	874
2 450					18 871	14 573	9 098	5 969	4 078	2 879	911
2 500					19 649	15 174	9 474	6 215	4 246	2 997	948
2 550					20 443	15 787	9 856	6 466	4 417	3 118	987
2 600						16 412	10 247	6 722	4 592	3 242	1 026
2 650						17 050	10 645	6 983	4 770	3 368	1 066
2 700						17 699	11 050	7 249	4 952	3 496	1 106
2 750						18 361	11 463	7 520	5 137	3 627	1 148
2 800						19 035	11 884	7 796	5 326	3 760	1 190
2 850						19 720	12 312	8 077	5 518	3 895	1 233
2 900						20 418	12 748	8 363	5 713	4 033	1 276
2 950							13 191	8 654	5 912	4 173	1 321
3 000							13 642	8 950	6 114	4 316	1 366
3 050							14 101	9 251	6 319	4 461	1 412
3 100							14 567	9 557	6 528	4 609	1 458
3 150							15 040	9 867	6 741	4 758	1 506

l/min x 0.264 = gal/min kPa x 0.125 = psi kg/l = sp.gr kg/l x 8.35 = lb/gal

CALCULATIONS OF PRESSURE DROP IN NOZZLES (continued)

Combination of two nozzles

$$P_d = \frac{dQ^2}{2959.41 \times (0.95)^2 A^2} \quad (\text{kPa}) \quad d = 1, \quad A = \text{nozzle area (in}^2)$$

Nozzles (1/32)	11-11	12-12	13-13	14-14	15-15	16-16	18-18	20-20	22-22	24-24	32-32																																																																																																												
A (in ²)	0.1856	0.2209	0.2592	0.3007	0.3451	0.3927	0.497	0.6136	0.7424	0.8836	1.5708																																																																																																												
Flow rate Q (l/min)	3 200	3 250	3 300	3 350	3 400	3 450	3 500	3 550	3 600	3 650	3 700	3 750	3 800	3 850	3 900	3 950	4 000	4 050	4 100	4 150	4 200	4 250	4 300	4 350	4 400	4 450	4 500																																																																																												
	15 522	16 010	16 507	17 011	17 522	18 042	18 568	19 103	19 644	20 194	20 751	10 183	10 504	10 829	11 160	11 496	11 836	12 182	12 532	12 888	13 248	13 614	13 984	14 360	14 740	15 125	15 516	15 911	16 311	16 716	17 127	17 542	17 962	18 387	18 817	19 252	19 692	20 137	6 956	7 175	7 398	7 624	7 853	8 086	8 322	8 561	8 804	9 050	9 300	9 553	9 809	10 069	10 332	10 599	10 869	11 142	11 419	11 700	11 983	12 270	12 561	12 854	13 152	13 452	13 756	4 911	5 065	5 222	5 382	5 544	5 708	5 875	6 044	6 215	6 389	6 565	6 744	6 925	7 108	7 294	7 482	7 673	7 866	8 061	8 259	8 459	8 662	8 867	9 074	9 284	9 496	9 711	1 554	1 603	1 652	1 703	1 754	1 806	1 859	1 912	1 967	2 022	2 077	2 134	2 191	2 249	2 308	2 368	2 428	2 489	2 551	2 613	2 677	2 741	2 806	2 871	2 938	3 005	3 073

l/min x 0.264 = gal/min kPa x 0.125 = psi kg/l = sp.gr kg/l x 8.35 = lb/gal

TABLE OF NOZZLE AREAS

Combinations of three nozzles

A = total area of nozzle combination (in²)
S = total area of nozzle combination (cm²)

Nozzles (1/32 in)	A (in ²)	S (cm ²)	Nozzles (1/32 in)	A (in ²)	S (cm ²)	Nozzles (1/32 in)	A (in ²)	S (cm ²)
8-8-8	0.1473	0.9501	16-16-17	0.6144	3.9636	24-24-25	1.3629	8.7932
8-8-9	0.1603	1.0342	16-17-17	0.6397	4.1269	24-25-25	1.4005	9.0356
8-9-9	0.1733	1.1183	17-17-17	0.6650	4.2902	25-25-25	1.4381	9.2781
9-9-9	0.1864	1.2024	17-17-18	0.6918	4.4634	25-25-26	1.4772	9.5305
9-9-10	0.2010	1.2965	17-18-18	0.7187	4.6366	25-26-26	1.5163	9.7828
9-10-10	0.2155	1.3905	18-18-18	0.7455	4.8098	26-26-26	1.5555	10.0352
10-10-10	0.2301	1.4845	18-18-19	0.7739	4.9929	26-26-27	1.5961	10.2974
10-10-11	0.2462	1.5884	18-19-19	0.8023	5.1759	26-27-27	1.6368	10.5597
10-11-11	0.2623	1.6923	19-19-19	0.8307	5.3590	27-27-27	1.6774	10.8220
11-11-11	0.2784	1.7962	19-19-20	0.8606	5.5520	27-27-28	1.7196	11.0941
11-11-12	0.2961	1.9100	19-20-20	0.8905	5.7450	27-28-28	1.7618	11.3663
11-12-12	0.3137	2.0239	20-20-20	0.9204	5.9380	28-28-28	1.8040	11.6384
12-12-12	0.3313	2.1377	20-20-21	0.9518	6.1409	28-28-29	1.8477	11.9205
12-12-13	0.3505	2.2614	20-21-21	0.9833	6.3437	28-29-29	1.8914	12.2025
12-13-13	0.3697	2.3851	21-21-21	1.0147	6.5466	29-29-29	1.9351	12.4846
13-13-13	0.3889	2.5088	21-21-22	1.0477	6.7594	29-29-30	1.9804	12.7765
13-13-14	0.4096	2.6424	21-22-22	1.0807	6.9722	29-30-30	2.0256	13.0685
13-14-14	0.4303	2.7760	22-22-22	1.1137	7.1850	30-30-30	2.0709	13.3605
14-14-14	0.4510	2.9096	22-22-23	1.1482	7.4076	30-30-31	2.1177	13.6623
14-14-15	0.4732	3.0531	22-23-23	1.1827	7.6303	30-31-31	2.1644	13.9641
14-15-15	0.4955	3.1966	23-23-23	1.2172	7.8530	31-31-31	2.2112	14.2660
15-15-15	0.5177	3.3401	23-23-24	1.2533	8.0855	31-31-32	2.2596	14.5777
15-15-16	0.5415	3.4935	23-24-24	1.2893	8.3181	31-32-32	2.3079	14.8895
15-16-16	0.5653	3.6469	24-24-24	1.3254	8.5507	32-32-32	2.3562	15.2012
16-16-16	0.5890	3.8003						

TABLE OF NOZZLE AREAS

Combinations of two nozzles

A = total area of nozzle combination (in²)
S = total area of nozzle combination (cm²)

Nozzles (1/32 in)	A (in ²)	S (cm ²)	Nozzles (1/32 in)	A (in ²)	S (cm ²)	Nozzles (1/32 in)	A (in ²)	S (cm ²)
8-8	0.0982	0.6334	16-17	0.4180	2.6968	24-25	0.9212	5.9429
8-9	0.1112	0.7175	17-17	0.4433	2.8601	25-25	0.9587	6.1854
9-9	0.1243	0.8016	17-18	0.4702	3.0333	25-26	0.9979	6.4378
9-10	0.1388	0.8956	18-18	0.4970	3.2065	26-26	1.0370	6.6901
10-10	0.1534	0.9897	18-19	0.5254	3.3896	26-27	1.0776	6.9524
10-11	0.1695	1.0936	19-19	0.5538	3.5727	27-27	1.1183	7.2146
11-11	0.1856	1.1975	19-20	0.5837	3.7657	27-28	1.1605	7.4868
11-12	0.2033	1.3113	20-20	0.6136	3.9587	28-28	1.2026	7.7590
12-12	0.2209	1.4251	20-21	0.6450	4.1615	28-29	1.2464	8.0410
12-13	0.2401	1.5488	21-21	0.6765	4.3644	29-29	1.2901	8.3231
13-13	0.2592	1.6725	21-22	0.7095	4.5772	29-30	1.3353	8.6150
13-14	0.2800	1.8061	22-22	0.7424	4.7900	30-30	1.3806	8.9070
14-14	0.3007	1.9397	22-23	0.7770	5.0126	30-31	1.4274	9.2088
14-15	0.3229	2.0832	23-23	0.8115	5.2353	31-31	1.4742	9.5107
15-15	0.3451	2.2267	23-24	0.8475	5.4679	31-32	1.5225	9.8224
15-16	0.3689	2.3801	24-24	0.8836	5.7005	32-32	1.5708	10.1341
16-16	0.3927	2.5335						

TABLE OF NOZZLE AREAS

A = area of nozzle (in²)

S = area of nozzle (cm²)

Nozzles (1/32 in)	A (in ²)	S (cm ²)	Nozzles (1/32 in)	A (in ²)	S (cm ²)	Nozzles (1/32 in)	A (in ²)	S (cm ²)
8	0.0491	0.3167	17	0.2217	1.4301	25	0.4794	3.0927
9	0.0621	0.4008	18	0.2485	1.6033	26	0.5185	3.3451
10	0.0767	0.4948	19	0.2769	1.7863	27	0.5591	3.6073
11	0.0928	0.5987	20	0.3068	1.9793	28	0.6013	3.8795
12	0.1104	0.7126	21	0.3382	2.1822	29	0.6450	4.1615
13	0.1296	0.8363	22	0.3712	2.3950	30	0.6903	4.4535
14	0.1503	0.9699	23	0.4057	2.6177	31	0.7371	4.7553
15	0.1726	1.1134	24	0.4418	2.8502	32	0.7854	5.0671

TABLE OF COEFFICIENTS N_4
Calculation of pressure loss in hole/drill collar annulus
 $P_{ann} = N_4 B$ (kPa/100 m)

Hole size (in)	5 5/8		5 3/4		5 7/8		6		6 1/8		6 1/4	
	4 3/4	4 1/8	4 3/4	4 1/8	4 3/4	4 1/8	4 3/4	4 1/8	4 3/4	4 1/8	4 3/4	4 1/8
100	12	3	8	2	6	2	4	1	3	1	2	1
150	26	6	17	4	12	3	8	3	6	2	5	2
200	43	10	28	7	20	6	14	5	10	4	8	3
250	65	14	43	11	29	9	21	7	15	6	12	5
300	90	20	59	15	41	12	29	10	21	8	16	6
350	119	26	78	20	54	16	38	13	28	10	21	8
400	151	34	99	26	68	20	49	16	36	13	27	11
450	187	41	123	32	84	25	60	20	44	16	33	13
500	226	50	148	39	102	30	73	24	53	19	40	16
550	268	60	176	46	121	36	86	28	64	23	48	19
600	314	70	206	54	141	42	101	33	74	27	56	22
650	362	80	238	62	163	48	117	38	86	31	65	25
700	414	92	271	71	187	55	133	44	98	35	74	29
750	469	104	307	80	211	63	151	50	111	40	84	33
800	526	117	345	90	237	70	169	56	125	45	94	37
850	587	130	385	100	265	78	189	62	139	50	105	41
900	651	144	427	111	293	87	209	69	154	56	116	45
950	717	159	470	122	323	96	231	76	170	61	128	50
1 000	787	175	516	134	355	105	253	84	186	67	141	55
1 050	859	191	563	147	387	115	276	91	203	74	153	60
1 100	934	207	612	159	421	125	301	99	221	80	167	65
1 150	1 012	225	663	173	456	135	326	107	240	87	181	71
1 200	1 092	242	716	186	492	146	351	116	259	93	195	76
1 250	1 176	261	771	201	530	157	378	125	278	101	210	82
1 300	1 262	280	827	215	569	168	406	134	299	108	225	88
1 350	1 350	300	885	230	609	180	434	143	320	116	241	94
1 400	1 442	320	945	246	650	193	464	153	341	123	258	101
1 450	1 536	341	1 007	262	692	205	494	163	364	131	274	107
1 500	1 632	362	1 070	279	736	218	525	173	386	140	292	114

l/min x 0.264 = gal/min

TABLE OF COEFFICIENTS N_4 (continued)
Calculation of pressure loss in hole/drill collar annulus $p_{ann} = N_4 B$ (kPa/100 m)

Hole size (in)	6 3/4			7 7/8			8 3/8			8 1/2		
	4 3/4	5 1/2	6	6 1/4	6 3/4	7	6	6 1/4	6 1/2	6 3/4	7	
100	1	3	1	1	3	2	0	0	1	1	2	0
150	2	7	2	2	7	3	1	1	1	2	3	1
200	3	11	3	3	11	6	1	1	2	3	6	1
250	5	17	4	4	16	8	2	2	3	5	8	2
300	6	23	5	5	23	11	3	3	5	7	11	2
350	8	30	7	8	30	15	4	4	6	9	15	3
400	11	38	9	11	38	19	5	5	8	12	19	4
450	13	48	11	14	47	24	6	6	10	15	24	5
500	16	57	14	17	57	29	7	7	12	18	29	6
550	19	68	16	20	68	34	8	8	14	21	34	7
600	22	80	19	24	80	40	9	9	17	25	40	8
650	25	92	22	28	92	46	10	10	19	29	46	9
700	29	105	25	32	105	53	12	12	22	33	53	10
750	33	119	28	37	119	60	13	13	25	37	60	11
800	37	134	32	42	134	67	15	15	28	42	67	12
850	41	149	35	47	149	75	16	16	31	47	75	13
900	45	166	39	53	165	83	18	18	35	52	83	14
950	50	182	43	58	182	91	20	20	38	57	91	15
1 000	55	200	47	64	200	100	22	22	42	62	100	17
1 050	60	218	52	70	218	109	24	24	46	68	109	18
1 100	65	238	56	77	237	119	26	26	50	74	119	20
1 150	70	257	61	84	257	128	28	28	54	80	128	22
1 200	76	278	66	91	277	139	30	30	58	87	139	24
1 250	82	299	71	105	298	149	33	33	62	93	149	26
1 300	88	321	76	113	320	160	35	35	67	100	160	28
1 350	94	343	81	121	342	171	38	38	72	107	171	30
1 400	100	367	87	129	366	183	40	40	77	114	183	32
1 450	107	391	92	138	389	195	43	43	82	122	195	34
1 500	114	415	98	146	414	207	45	45	87	129	207	36
1 550	120	440	104	155	439	220	48	48	92	137	220	38
1 600	128	466	110	164	465	233	51	51	97	145	233	41
1 650	135	493	117	174	491	246	54	54	103	153	246	43
1 700	142	520	123	183	519	260	57	57	109	162	260	45
1 750	150	548	130	193	546	273	60	60	114	171	273	48
1 800	158	576	136	203	575	288	63	63	120	180	288	51
1 850	166	606	143	213	604	302	66	66	126	189	302	53
1 900	174	635	150	224	633	317	69	69	133	198	317	56
1 950	182	666	158	234	664	332	73	73	139	207	332	59
2 000	191	697	165	245	695	348	76	76	146	217	348	61

l/min x 0.264 = gal/min

TABLE OF COEFFICIENTS N_4 (continued)
Calculation of pressure loss in hole/drill collar annulus $p_{ann} = N_4 B$ (kPa/100 m)

Hole size (in)	8 5/8						8 3/4						9 7/8						12 1/4					
	6 1/4	6 1/2	6 3/4	7	7 1/4	7 1/4	6 1/4	6 1/2	6 3/4	7	7 1/4	7 1/4	6 1/2	6 3/4	7 3/4	8	7 3/4	8	9 1/2	10	11 1/4			
100	0	0	1	1	1	1	0	1	1	1	1	0	0	0	0	0	0	0	0	0	2			
150	1	1	1	2	3	5	1	1	1	3	3	1	1	1	1	1	1	1	1	1	4			
200	2	2	3	5	8	11	1	2	3	4	6	1	1	1	2	2	2	2	2	2	7			
250	2	3	5	7	11	14	1	3	4	5	8	1	1	2	3	3	3	3	3	3	10			
300	3	4	6	9	14	18	2	3	4	5	11	1	1	2	3	4	4	4	4	4	14			
350	4	5	8	11	17	22	3	4	5	7	14	1	1	3	4	5	5	5	5	5	18			
400	5	6	9	14	22	27	4	5	7	9	17	1	1	4	5	6	6	6	6	6	23			
450	6	8	11	17	27	32	5	7	9	11	19	1	1	5	7	8	8	8	8	8	29			
500	7	10	13	20	32	38	6	8	9	13	21	2	2	6	7	9	9	9	9	9	35			
550	8	11	16	23	38	43	7	9	11	16	24	2	2	7	9	10	10	10	10	10	41			
600	9	13	18	27	43	50	8	11	13	18	29	3	3	8	10	12	12	12	12	12	48			
650	11	15	21	31	50	56	9	12	15	21	33	3	3	9	11	14	14	14	14	14	56			
700	12	17	23	35	56	63	10	14	17	24	38	4	4	10	12	16	16	16	16	16	64			
750	14	19	26	39	63	70	12	15	19	28	43	4	4	11	14	18	18	18	18	18	72			
800	15	21	29	44	70	78	13	17	21	31	48	4	4	12	15	20	20	20	20	20	81			
850	17	23	33	49	78	86	14	19	24	35	53	5	5	13	16	22	22	22	22	22	90			
900	19	25	36	54	86	94	16	21	26	38	59	5	5	14	18	25	25	25	25	25	100			
950	21	28	39	59	94	103	17	23	32	42	65	6	6	15	19	27	27	27	27	27	110			
1 000	22	30	43	64	103	112	19	25	35	46	72	6	6	16	20	30	30	30	30	30	121			
1 050	24	33	47	70	112	121	21	27	38	51	78	7	7	17	21	33	33	33	33	33	132			
1 100	26	36	51	76	121	131	22	30	41	55	85	7	7	18	22	36	36	36	36	36	144			
1 150	29	39	55	82	131	141	24	32	44	60	92	8	8	19	24	39	39	39	39	39	156			
1 200	31	42	59	88	141	151	26	35	48	64	99	8	8	20	27	42	42	42	42	42	168			
1 250	33	45	63	94	151	162	28	37	51	69	107	9	9	21	29	45	45	45	45	45	181			
1 300	35	48	68	101	162	173	30	40	55	74	115	10	10	22	30	48	48	48	48	48	194			
1 350	38	51	72	108	173	184	32	42	59	80	123	10	10	23	31	52	52	52	52	52	208			
1 400	40	54	77	115	184	196	34	45	62	85	131	11	11	24	33	55	55	55	55	55	222			
1 450	43	58	82	122	196	207	36	48	66	96	140	11	11	25	35	59	59	59	59	59	236			
1 500	45	61	87	129	207	220	38	51	70	102	149	13	13	26	37	62	62	62	62	62	251			
1 550	48	65	92	137	220	232	40	54	75	108	158	13	13	27	39	66	66	66	66	66	266			
1 600	51	69	97	145	232	245	43	57	79	114	167	14	14	28	41	70	70	70	70	70	282			
1 650	53	72	102	153	245	258	45	60	83	121	176	15	15	29	43	74	74	74	74	74	298			
1 700	56	76	108	161	258	272	48	63	88	127	186	16	16	30	45	78	78	78	78	78	314			
1 750	59	80	113	169	272	285	50	67	92	134	196	17	17	31	47	82	82	82	82	82	331			
1 800	62	84	119	178	285	299	53	70	97	140	206	18	18	32	49	87	87	87	87	87	348			
1 850	65	88	125	187	299	314	55	73	102	147	217	19	19	33	51	91	91	91	91	91	366			
1 900	68	93	131	196	314	328	58	77	106	154	227	20	20	34	53	95	95	95	95	95	384			
1 950	72	97	137	205	328	342	60	81	111	162	238	21	21	35	55	100	100	100	100	100	402			
2 000											249	21	21	36	57	105	105	105	105	105	421			

l/min x 0.264 = gal/min

TABLE OF COEFFICIENTS N_4 (continued)
Calculation of pressure loss in hole/drill collar annulus $p_{ann} = N_4 B$ (kPa/100 m)

Hole size (in)	8 5/8				8 3/4				9 7/8				12 1/4						
	6 1/4	6 1/2	6 3/4	7	7 1/4	6 1/4	6 1/2	6 3/4	7	7 1/4	6 1/2	6 3/4	7 3/4	8	7 3/4	8	9 1/2	10	11 1/4
2 050	75	101	143	214	343	63	84	116	169	261	22	27	77	109	6	7	24	43	440
2 100	78	106	150	223	358	66	88	122	176	272	23	28	80	114	7	8	25	45	460
2 150	82	111	156	233	374	69	92	127	184	284	24	29	84	119	7	8	27	46	480
2 200	85	115	163	243	390	72	96	132	192	296	25	31	87	124	7	8	28	48	500
2 250	89	120	170	253	406	75	100	138	200	308	26	32	91	129	8	9	29	50	521
2 300	92	125	176	263	422	78	104	143	208	321	27	33	95	134	8	9	30	52	542
2 350	96	130	183	274	439	81	108	149	216	333	28	34	98	140	8	10	31	55	563
2 400	99	135	190	284	456	84	112	155	224	346	29	36	102	145	9	10	32	57	585
2 450	103	140	198	295	473	87	116	160	233	359	30	37	106	151	9	10	34	59	607
2 500	107	145	205	306	491	90	120	166	241	373	31	38	110	156	9	11	35	61	629
2 550	111	150	212	317	508	94	125	172	250	386	33	40	114	162	10	11	36	63	652
2 600	115	156	220	328	526	97	129	179	259	400	34	41	118	168	10	12	37	65	676
2 650	119	161	228	340	545	100	134	185	268	414	35	43	122	174	10	12	39	68	699
2 700	123	167	235	351	563	104	138	191	277	428	36	44	126	179	11	12	40	70	723
2 750	127	172	243	363	582	107	143	198	287	442	37	46	131	186	11	13	41	72	747
2 800	131	178	251	375	602	111	148	204	296	457	38	47	135	192	11	13	43	75	772
2 850	135	184	259	387	621	114	152	211	306	472	40	49	139	198	12	14	44	77	797
2 900	140	189	268	399	641	118	157	217	315	487	41	50	144	204	12	14	45	80	822
2 950	144	195	276	412	661	122	162	224	325	502	42	52	148	210	12	14	47	82	848
3 000	149	201	285	425	681	125	167	231	335	517	44	53	153	217	13	15	48	85	874
3 050	153	207	293	437	702	129	172	238	345	533	45	55	157	224	13	15	50	87	900
3 100	158	214	302	450	723	133	177	245	355	549	46	57	162	230	14	16	51	90	927
3 150	162	220	311	464	744	137	182	252	366	565	48	58	167	237	14	16	53	92	954
3 200	167	226	320	477	765	141	188	260	376	581	49	60	172	244	14	17	54	95	982
3 250	172	233	329	490	787	145	193	267	387	597	50	62	177	251	15	17	56	98	1 009
3 300	176	239	338	504	809	149	198	274	398	614	52	63	181	258	15	18	57	101	1 038
3 350	181	246	347	518	831	153	204	282	409	631	53	65	186	265	16	18	59	103	1 066
3 400	186	252	356	532	853	157	209	289	420	648	55	67	191	272	16	19	61	106	1 095
3 450	191	259	366	546	876	161	215	297	431	665	56	69	197	279	16	19	62	109	1 124
3 500	196	266	376	560	899	166	221	305	442	683	57	70	202	286	17	20	64	112	1 153
3 550	201	273	385	575	922	170	226	313	454	700	59	72	207	294	17	20	65	115	1 183
3 600	206	280	395	590	946	174	232	321	465	718	60	74	212	301	18	21	67	118	1 213
3 650	212	287	405	604	969	179	238	329	477	736	62	76	218	309	18	21	69	121	1 244
3 700	217	294	415	619	994	183	244	337	489	755	64	78	223	316	19	22	70	123	1 275
3 750	222	301	425	634	1 018	188	250	345	501	773	65	80	228	324	19	22	72	127	1 306
3 800	227	308	435	650	1 042	192	256	354	513	792	67	82	234	332	20	23	74	130	1 337
3 850	233	315	446	665	1 067	197	262	362	525	810	68	84	240	340	20	23	76	133	1 369
3 900	238	323	456	681	1 092	201	268	371	537	830	70	86	245	348	21	24	77	136	1 402
3 950	244	330	467	697	1 118	206	274	379	550	849	71	88	251	356	21	24	79	139	1 434

l/min x 0.264 = gal/min

TABLE OF COEFFICIENTS N_4 (continued)
Calculation of pressure loss in hole/drill collar annulus $p_{ann} = N_4 B$ (kPa/100 m)

Hole size (in)	15										17 1/2			
	7 3/4	8	9 1/2	10	11	11 1/4	7 3/4	8	9 1/2	10	11	11 1/4	14	
2 000	1	1	2	3	5	7	0	0	1	1	1	1	6	
2 100	1	1	3	3	6	7	0	0	1	1	1	1	6	
2 200	1	2	3	4	7	8	0	1	1	1	1	1	7	
2 300	2	2	3	4	7	8	1	1	1	1	2	2	7	
2 400	2	2	3	4	8	9	1	1	1	1	2	2	8	
2 500	2	2	4	5	9	10	1	1	1	1	2	2	9	
2 600	2	2	4	5	9	10	1	1	1	1	2	2	9	
2 700	2	2	4	5	9	11	1	1	1	1	2	2	10	
2 800	2	2	4	6	10	12	1	1	1	1	2	2	11	
2 900	2	2	5	6	11	13	1	1	1	1	2	2	11	
3 000	2	3	5	6	11	14	1	1	1	2	2	3	12	
3 100	3	3	5	7	12	15	1	1	1	2	3	3	13	
3 200	3	3	5	7	13	16	1	1	1	2	3	3	14	
3 300	3	3	6	7	14	17	1	1	2	3	3	3	14	
3 400	3	3	6	8	14	18	1	1	2	3	3	3	15	
3 500	3	3	6	8	15	19	1	1	2	3	3	3	16	
3 600	3	4	7	9	16	20	1	1	2	3	3	3	17	
3 700	4	4	7	9	17	21	1	1	2	3	4	4	18	
3 800	4	4	8	10	18	22	1	1	2	3	4	4	18	
3 900	4	4	8	10	19	23	1	1	2	3	4	4	19	
4 000	4	4	9	11	20	24	1	2	2	3	4	4	20	
4 100	4	5	9	11	21	25	2	2	2	3	4	5	21	
4 200	4	5	9	11	22	26	2	2	2	3	4	5	22	
4 300	4	5	9	12	22	27	2	2	3	3	4	5	23	
4 400	5	5	10	12	23	28	2	2	3	3	4	5	24	
4 500	5	5	10	13	24	29	2	2	3	3	4	5	25	
4 600	5	6	11	14	25	30	2	2	3	3	4	5	26	
4 700	5	6	11	14	26	31	2	2	3	3	4	5	27	
4 800	6	6	11	15	27	32	2	2	3	3	4	6	28	
4 900	6	6	12	15	28	33	2	2	3	3	4	6	29	
5 000	6	7	12	16	29	34	2	2	3	3	4	6	30	
5 100	6	7	13	16	30	35	2	2	3	3	4	6	31	
5 200	7	7	13	17	31	37	2	2	4	4	4	7	32	
5 300	7	7	14	17	32	38	2	2	4	4	4	7	34	
5 400	7	8	14	18	33	39	2	2	4	4	4	7	35	
5 500	8	8	15	19	34	40	3	3	4	5	5	7	36	
5 600	8	8	15	19	35	42	3	3	4	5	5	8	37	
5 700	8	8	15	20	36	43	3	3	4	5	5	8	38	
5 800	8	9	16	20	37	44	3	3	4	5	5	8	39	

l/min x 0.264 = gal/min

TABLE OF COEFFICIENTS N_5
Calculation of pressure loss in hole/pipe annulus $p_{ann} = N_5 B$ (kPa/100 m)

Hole size (in)	5 5/8						5 3/4						5 7/8					
	2 3/8		2 7/8		3 1/2		2 3/8		2 7/8		3 1/2		2 3/8		2 7/8		3 1/2	
	3 3/8	3 7/8	4 1/2	4 3/4	5	3 3/8	3 7/8	4 1/2	4 3/8	4 1/2	4 3/4	5	3 3/8	3 7/8	4 1/2	4 3/8	4 1/2	4 3/4
100	0	1	1	2	3	0	1	1	1	1	2	2	0	0	1	1	1	1
150	1	3	5	6	9	1	2	4	2	3	4	6	1	1	2	1	2	3
200	1	4	7	9	14	2	3	6	3	5	7	9	2	2	3	3	4	5
250	2	5	10	12	19	3	4	8	4	6	9	13	2	3	4	5	6	7
300	3	6	13	16	26	4	5	10	5	8	12	17	3	4	5	6	7	9
350	4	8	16	20	33	5	7	13	6	10	15	22	4	6	8	11	12	16
400	5	10	18	23	39	6	9	16	8	13	19	27	5	7	10	13	15	19
450	6	12	20	25	40	7	10	17	9	14	21	30	6	8	11	14	16	21
500	8	14	22	28	44	8	12	19	11	16	23	32	7	9	12	15	18	23
550	9	16	24	30	47	9	14	21	12	17	25	34	8	10	13	16	19	25
600	10	18	27	34	51	10	16	23	14	19	27	37	9	12	15	18	22	29
650	12	19	30	37	55	12	17	25	16	21	29	39	10	13	17	20	24	31
700	14	21	33	40	59	14	18	27	18	23	31	41	12	15	19	23	27	35
750	16	24	36	43	63	16	20	29	20	25	33	43	14	17	22	26	31	39
800	18	27	39	46	67	18	22	31	22	27	35	45	15	19	24	29	34	42
850	20	30	41	48	71	20	24	33	24	29	37	47	17	21	27	32	37	46
900	22	33	44	51	75	22	26	35	26	31	39	49	18	23	29	34	40	49
950	24	37	47	54	79	24	28	37	28	33	41	51	20	25	31	37	43	52
1 000	26	40	50	57	83	26	30	39	30	35	43	53	22	27	33	39	45	54
1 050	29	44	54	61	87	29	33	42	33	38	46	56	25	30	36	42	49	58
1 100	31	48	58	65	91	31	35	45	35	40	48	58	27	32	38	44	51	60
1 150	34	52	62	70	95	34	37	48	37	42	50	60	29	34	40	47	54	63
1 150	36	56	66	74	99	36	39	50	39	44	52	62	31	36	42	49	56	65
1 200	39	60	70	78	103	39	41	52	41	46	54	64	33	38	44	51	58	67
1 250	42	65	75	83	107	42	44	55	44	49	57	67	35	40	46	53	60	69
1 300	45	69	79	87	111	45	47	57	47	52	60	70	37	42	48	55	62	71
1 350	48	74	84	92	115	48	50	60	50	55	63	73	39	44	50	57	64	73
1 400	51	79	89	97	119	51	53	63	53	58	66	76	41	46	52	59	66	75
1 450	55	83	93	101	123	55	56	66	56	61	69	79	44	49	55	62	69	78
1 500	58	88	98	106	127	58	59	69	59	64	72	82	46	51	57	64	71	80
1 550	61	94	104	112	131	61	62	72	62	67	75	85	48	53	59	66	73	82
1 600	65	99	109	117	135	65	66	76	65	70	78	88	51	56	62	69	76	85
1 650	68	105	115	123	139	68	69	79	68	73	81	91	53	58	64	71	78	87
1 700	72	110	120	128	143	72	73	83	72	77	85	95	56	61	67	74	81	90
1 800	76	116	126	134	147	76	77	87	76	81	89	99	59	64	70	77	84	93
1 850	80	122	132	140	151	80	81	91	80	85	93	103	62	67	73	80	87	96
1 900	83	128	138	146	157	83	84	94	83	88	96	106	65	70	76	83	90	99
1 950	87	134	144	152	163	87	88	98	87	92	100	110	68	73	79	86	93	102
2 000	91	140	150	158	169	91	92	102	91	96	104	114	72	77	83	90	97	106

l/min x 0.264 = gal/min

TABLE OF COEFFICIENTS N_5 (continued)
Calculation of pressure loss in hole/pipe annulus $p_{ann} = N_5 B$ (kPa/100 m)

Hole size (in)	6						6 1/8						6 1/4						6 3/4					
	3 1/2			4			3 1/2			4			3 1/2			4			3 1/2			4		
	4 1/2	4 3/4	5	5 1/4	5 1/2	5 3/4	4 1/2	4 3/4	5	5 1/4	5 1/2	5 3/4	4 1/2	4 3/4	5	5 1/4	5 1/2	5 3/4	4 1/2	4 3/4	5	5 1/4	5 1/2	5 3/4
500	13	14	18	35	41	48	11	12	14	25	41	9	10	11	19	27	27	27	5	5	5	8	9	19
550	15	17	21	41	49	57	13	14	16	30	49	11	12	13	23	32	32	32	6	6	6	10	11	22
600	18	20	24	48	57	66	15	16	19	35	57	13	14	15	27	38	38	38	7	7	7	11	13	26
650	21	23	28	56	66	75	17	19	22	40	66	15	16	18	31	44	44	44	8	8	8	13	15	30
700	24	26	32	64	75	85	20	22	25	46	75	17	18	20	35	50	50	50	9	9	9	15	17	35
750	27	30	37	72	85	95	22	24	29	52	85	19	20	23	40	57	57	57	10	11	11	17	19	39
800	30	34	41	81	95	106	25	27	32	59	95	21	23	26	45	63	63	63	11	12	13	19	22	44
850	34	37	46	90	106	118	28	31	36	66	106	24	25	29	50	71	71	71	13	13	14	21	24	49
900	37	42	51	100	118	130	31	34	40	73	118	26	28	32	55	78	78	78	14	15	16	24	27	54
950	41	46	56	110	130	142	34	37	44	80	130	29	31	35	61	86	86	86	15	16	17	26	30	60
1 000	45	50	61	121	142	156	38	41	48	88	142	32	34	39	67	95	95	95	17	18	19	29	33	66
1 050	49	55	67	132	156	170	41	45	52	96	156	34	37	42	73	104	104	104	18	19	21	31	36	72
1 100	54	60	73	143	170	183	45	49	57	104	170	37	40	46	79	113	113	113	20	21	22	34	39	78
1 150	58	65	79	155	183	198	48	53	62	113	183	41	44	50	86	122	122	122	22	23	24	37	42	84
1 200	63	70	85	168	198	212	52	57	67	122	198	44	47	54	93	132	132	132	23	24	26	40	45	91
1 250	68	75	92	181	212	228	56	61	72	131	212	47	51	58	100	142	142	142	25	26	28	43	49	98
1 300	72	81	98	194	228	245	60	66	77	141	228	51	54	62	107	152	152	152	27	28	30	46	52	105
1 350	78	86	105	207	245	261	64	70	82	151	245	54	58	66	115	163	163	163	29	30	32	49	56	113
1 400	83	92	112	221	261	278	69	75	88	161	261	58	62	71	122	174	174	174	31	32	35	52	60	120
1 450	88	98	120	236	278	296	73	80	94	171	278	62	66	75	130	185	185	185	33	34	37	56	64	128
1 500	94	104	127	251	296	314	78	85	100	182	296	65	70	80	139	197	197	197	35	37	39	59	68	136
1 550	99	110	135	266	314	332	83	90	106	193	314	69	75	85	147	209	209	209	37	39	41	63	72	145
1 600	105	117	143	282	332	351	88	96	112	205	332	73	79	90	156	221	221	221	39	41	44	67	76	153
1 650	111	124	151	298	351	370	93	101	118	216	351	78	84	95	165	234	234	234	42	43	46	70	80	162
1 700	117	130	159	314	370	390	98	107	125	228	370	82	88	100	174	247	247	247	44	46	49	74	85	171
1 750	124	137	168	331	390	410	103	112	131	241	390	86	93	106	183	260	260	260	46	48	52	78	89	180
1 800	130	145	176	348	410	431	108	118	138	253	410	91	98	111	192	273	273	273	49	51	54	82	94	189
1 850	137	152	185	366	431	452	114	124	145	266	431	95	103	117	202	287	287	287	51	53	57	87	99	199
1 900	143	159	195	384	452	474	119	130	152	279	452	100	108	123	212	301	301	301	54	56	60	91	103	209
1 950	150	167	204	402	474	496	125	136	160	292	474	105	113	128	222	316	316	316	56	59	63	95	108	219
2 000	157	175	213	421	496	518	131	143	167	306	496	110	118	134	233	330	330	330	59	61	66	100	113	229

l/min x 0.264 = gal/min

TABLE OF COEFFICIENTS N_5 (continued)
Calculation of pressure loss in hole/pipe annulus $p_{ann} = N_5 B$ (kPa/100 m)

Hole size (in)	7 7/8			8 3/8			8 1/2			8 5/8			8 3/4		
	3 1/2	4	4 1/2	3 1/2	4	4 1/2	3 1/2	4	4 1/2	3 1/2	4	4 1/2	3 1/2	4	4 1/2
Nominal pipe size (in)	4 1/2-5	5 1/4-6	6-6 3/8	4 1/2-5	5 1/4-6	6-6 3/8	4 1/2-5	5 1/4-6	6-6 3/8	4 1/2-5	5 1/4-6	6-6 3/8	4 1/2-5	5 1/4-6	6-6 3/8
Tool joint outside diameter (in)	4 3/4	5 1/2	6 1/4	4 3/4	5 3/8	6 3/16	6 1/2	6 3/16	6 1/2	4 3/4	5 1/2	6 3/16	6 1/2	4 3/4	5 3/8
Average outside diameter (in)	2	2	4	1	1	2	3	2	3	1	1	2	3	1	2
500	2	3	4	1	2	2	4	1	2	1	2	2	3	1	2
550	2	3	5	1	2	3	4	2	3	1	2	3	1	2	3
600	3	4	6	2	2	3	5	3	4	1	2	3	1	2	3
650	3	4	7	2	3	4	5	4	5	2	3	4	2	3	4
700	3	4	8	2	3	4	6	5	6	2	3	4	2	3	4
750	4	5	9	3	3	4	7	6	7	2	3	4	2	3	4
800	4	6	10	3	4	5	8	7	8	2	3	4	2	3	4
850	4	7	11	3	4	6	9	8	9	3	4	5	2	3	4
900	5	8	12	3	5	7	10	9	10	3	4	6	3	4	5
950	5	9	13	4	5	8	11	10	11	3	4	7	3	4	5
1 000	6	10	14	4	6	9	12	11	12	4	5	8	3	4	5
1 050	6	11	15	4	7	10	13	12	13	4	5	9	3	4	5
1 100	7	12	16	5	8	11	14	13	14	5	6	10	4	5	6
1 150	8	13	17	5	9	12	15	14	15	5	6	11	4	5	6
1 200	8	14	18	6	10	13	16	15	16	6	7	12	4	5	6
1 250	9	15	19	6	11	14	17	16	17	6	7	13	4	5	6
1 300	10	16	20	7	12	15	18	17	18	7	8	14	5	6	7
1 350	10	17	21	7	13	16	19	18	19	7	8	15	5	6	7
1 400	11	18	22	8	14	17	20	19	20	8	9	16	6	7	8
1 450	11	19	23	8	15	18	21	20	21	8	9	17	6	7	8
1 500	12	20	24	9	16	19	22	21	22	9	10	18	7	8	9
1 550	12	21	25	9	17	20	23	22	23	9	10	19	7	8	9
1 600	13	22	26	10	18	21	24	23	24	10	11	20	8	9	10
1 650	14	23	27	10	19	22	25	24	25	10	11	21	8	9	10
1 700	15	24	28	11	20	23	26	25	26	11	12	22	9	10	11
1 750	15	25	29	11	21	24	27	26	27	11	12	23	9	10	11
1 800	16	26	30	12	22	25	28	27	28	12	13	24	10	11	12
1 850	16	27	31	12	23	26	29	28	29	12	13	25	10	11	12
1 900	18	28	32	13	24	27	30	29	30	13	14	26	11	12	13
1 950	18	29	33	13	25	28	31	30	31	13	14	27	11	12	13
2 000	20	30	34	14	26	29	32	31	32	14	15	28	12	13	14
2 050	21	31	35	14	27	30	33	32	33	14	15	29	12	13	14
2 100	22	32	36	15	28	31	34	33	34	15	16	30	13	14	15
2 150	22	33	37	15	29	32	35	34	35	15	16	31	13	14	15
2 200	23	34	38	16	30	33	36	35	36	16	17	32	14	15	16

l/min x 0.264 = gal/min

TABLE OF COEFFICIENTS N_5 (continued)
Calculation of pressure loss in hole/pipe annulus $p_{ann} = N_5 B$ (kPa/100 m)

Hole size (in)	9 7/8			12 1/4			15			17 1/2		
	4 1/2	5	5 1/2	4 1/2	5	5 1/2	4 1/2	5	5 1/2	4 1/2	5	5 1/2
Nominal pipe size (in)												
Tool joint outside diameter (in)	6-6 3/8	6 3/8-7	7-7 1/2	6-6 3/8	6 3/8-7	7-7 1/2	6-6 3/8	6 3/8-7	7-7 1/2	6-6 3/8	6 3/8-7	7-7 1/2
Average outside diameter (in)	6	6 1/2	7 1/4	6	6 1/2	7 1/4	6	6 1/2	7 1/4	6	6 1/2	7 1/4
Flow rate Q (l/min)	1 500	5	7	1	1	1	0	0	0	0	0	0
	1 600	6	8	2	1	2	0	0	0	0	0	0
	1 700	5	9	2	1	2	0	0	0	0	0	0
	1 800	6	7	10	1	2	0	0	0	0	0	0
	1 900	6	8	11	2	2	0	0	1	1	0	0
	2 000	7	9	12	2	2	0	0	1	1	0	0
	2 100	8	10	13	2	2	0	0	1	1	0	0
	2 200	8	11	15	2	2	0	0	1	1	0	0
	2 300	9	11	16	2	2	0	0	1	1	0	0
	2 400	10	12	17	2	3	0	0	1	1	0	0
	2 500	10	13	18	3	3	0	0	1	1	0	0
	2 600	11	14	20	3	3	0	0	1	1	0	0
	2 700	11	15	21	3	3	0	0	1	1	0	0
	2 800	13	16	23	3	4	0	0	1	1	0	0
	2 900	14	17	24	3	4	0	0	1	1	0	0
	3 000	14	19	26	4	4	0	0	1	1	0	0
	3 100	15	20	27	4	4	0	0	1	1	0	0
	3 200	16	21	29	4	4	0	0	1	1	0	0
	3 300	17	22	30	4	4	0	0	1	1	0	0
	3 400	18	23	32	4	5	0	0	1	2	0	0
	3 500	19	24	34	4	5	0	0	1	2	0	0
	3 600	20	26	35	5	6	0	0	1	2	0	0
	3 700	21	27	37	5	6	0	0	1	2	0	0
	3 800	22	28	39	5	6	0	0	1	2	0	0
	3 900	23	30	41	6	7	0	0	1	2	0	0
	4 000	24	31	43	6	7	0	0	1	2	0	0
4 100	25	32	45	6	7	0	0	1	2	0	0	
4 200	27	34	47	6	8	0	0	1	2	0	0	
4 300	28	35	49	7	8	0	0	1	2	0	0	
4 400	29	37	51	7	8	0	0	1	2	0	0	
4 500	30	38	53	7	9	0	0	1	2	0	0	
4 600	31	40	55	7	9	0	0	1	2	0	0	
4 700	32	42	57	8	9	0	0	1	2	0	0	
4 800	34	43	60	8	10	0	0	1	2	0	0	
4 900	35	44	62	9	10	0	0	1	2	0	0	
5 000	36	46	64	9	10	0	0	1	2	0	0	

l/min x 0.264 = gal/min

EQUIVALENT LENGTHS FOR SPECIAL LINE CONNECTIONS (in meter)

The values given in the table are approximate averages. However, the table offers a quick way to find the pressure drops in a low pressure circuit. For a change in pipe size, the calculation is always carried out in relation to the smaller size (d).

Diagram	Equivalent length for pipe size				
	3"	4"	6"	8"	10"
	0.8	1.1	1.8	2.5	3.3
	1.9	2.7	4.5	6.4	8.3
	0.4	0.54	0.9	1.3	1.7
	3.4	4.8	8.1	11.5	14.8
	0.8	1.1	1.8	2.5	3.3
	1.9	2.7	4.5	6.4	8.3
	3.8	5.4	9.0	12.7	16.5
	1.2	1.6	2.7	3.8	5.0
	1.5	2.1	3.6	5.1	6.6
	2.7	3.8	6.3	8.9	11.6
	4.6	6.4	10.8	15.2	19.8
	0.6	0.8	1.4	1.9	2.5
	1.5	2.1	3.6	5.1	6.6
	2.7	3.8	6.3	8.9	11.5
	3.6	5.1	8.5	12.1	15.7
	0.4	0.6	0.9	1.3	1.7
	0.6	0.8	1.4	1.9	2.5
	0.8	1.1	1.8	2.5	3.3
	1.3	1.7	3.2	4.4	5.8
	0.5	0.7	1.2	1.6	2.1
	0.6	0.9	1.5	2.0	2.6
	1.2	1.7	2.9	4.0	5.3
	0.5	0.7	1.1	1.5	2.0
	1.2	1.6	2.7	3.8	5.0

Diagram	Equivalent length for pipe size				
	3"	4"	6"	8"	10"
	1.0	1.3	2.2	3.2	4.1
	0.6	0.8	1.3	1.9	2.5
	1.2	1.6	2.7	3.8	5.0
	1.5	2.1	3.6	5.1	6.6
	1.7	2.4	4.0	5.7	7.4
	0.6	0.8	1.4	1.9	2.5
	1.5	2.1	3.6	5.1	6.6
	2.7	3.8	6.3	8.9	11.5
	3.6	5.1	8.5	12.1	15.7
	0.4	0.6	0.9	1.3	1.7
	0.6	0.8	1.4	1.9	2.5
	0.8	1.1	1.8	2.5	3.3
	1.3	1.7	3.2	4.4	5.8
	0.5	0.7	1.2	1.6	2.1
	0.6	0.9	1.5	2.0	2.6
	1.2	1.7	2.9	4.0	5.3
	0.5	0.7	1.1	1.5	2.0
	1.2	1.6	2.7	3.8	5.0

H

drilling mud

Relationship between mud weight and pressure head of mud.....	H1
Increase of mud specific gravity with barite ($d = 4.2$) Weight (in kg) of barite to add to 1 m ³ of mud (M).....	H2
Increase of mud specific gravity with calcium carbonate ($d = 2.65$). Weight (in kg) of calcium carbonate to add to 1 m ³ of mud (M).....	H3
Mud specific gravity reduction with water ($d = 1$) Water volume in liters to add to 1 m ³ of mud (M).....	H4
Mud specific gravity reduction with oil ($d = 0.85$) Oil volume in liters to add to 1 m ³ of mud (M).....	H5
Final volume V_F (in liters) after adding weighting material of specific gravity d_a to 1 m ³ of mud. M_a weight of weighting material added (kg/m ³).....	H6
Mud volume (in liters) required to prepare 1 m ³ of mud weighted with barite ($d = 4.2$).....	H7
Ternary diagram for determining solid content of mud (water base muds).....	H8
Ternary diagram m for determining solid content of mud (saturated salt water mud).....	H9
Properties of sodium chloride solutions.....	H10
Properties of calcium chloride solutions.....	H11
Properties of potassium chloride solutions.....	H12
Properties of sodium carbonate (Na ₂ CO ₃) solutions....	H13

Properties of potassium carbonate (K_2CO_3) solutions..	H14
Properties of sodium bromide (NaBr) solutions.....	H15
Effect of temperature on densities of calcium chloride and sodium chloride solutions (Field Data Handbook, Dowel Schlumberger).....	H16
Grain size classification of solids ($1\mu = 0.000001$ m)	H17
Shale shaker screens.....	H18
Screen standards.....	H19
Air/gas flow rate required for drilling. Data for calculating approximate circulation rates required to produce a minimum annular velocity which is equivalent in lifting power to a standard air velocity of 914 m/min (3000 ft/h).....	H20

RELATIONSHIP BETWEEN MUD WEIGHT AND PRESSURE HEAD OF MUD

Mud weight			Fluid head	
(kg/l)	(lb/gal)	(lb/ft ³)	(psi/ft)	(kPa/m)
0.90	7.51	56.20	0.39	8.83
0.92	7.68	57.40	0.40	9.03
0.94	7.84	58.70	0.41	9.22
0.96	8.01	59.90	0.42	9.42
0.98	8.18	61.20	0.42	9.61
1.00	8.35	62.40	0.43	9.81
1.02	8.51	63.70	0.44	10.01
1.04	8.68	64.90	0.45	10.20
1.06	8.85	66.20	0.46	10.40
1.08	9.01	67.40	0.47	10.59
1.10	9.18	68.70	0.48	10.79
1.12	9.35	69.90	0.49	10.99
1.14	9.51	71.20	0.49	11.18
1.16	9.68	72.40	0.50	11.38
1.18	9.85	73.70	0.51	11.58
1.20	10.01	74.90	0.52	11.77
1.22	10.18	76.20	0.53	11.97
1.24	10.35	77.40	0.54	12.16
1.26	10.51	78.70	0.55	12.36
1.28	10.68	79.90	0.55	12.56
1.30	10.85	81.20	0.56	12.75
1.34	11.18	83.70	0.58	13.15
1.38	11.52	86.10	0.60	13.54
1.42	11.85	88.60	0.62	13.93
1.46	12.18	91.10	0.63	14.32
1.50	12.52	93.60	0.65	14.72
1.54	12.85	96.10	0.67	15.11
1.58	13.19	98.60	0.69	15.50
1.62	13.52	101.10	0.70	15.89
1.66	13.85	103.60	0.72	16.28
1.70	14.19	106.10	0.74	16.68
1.74	14.52	108.60	0.75	17.07
1.78	14.85	111.10	0.77	17.46
1.82	15.19	113.60	0.79	17.85
1.86	15.52	116.10	0.81	18.25
1.90	15.86	118.60	0.82	18.64
1.94	16.19	121.10	0.84	19.03
1.98	16.52	123.60	0.86	19.42
2.02	16.86	126.10	0.88	19.82
2.06	17.19	128.60	0.89	20.21
2.10	17.52	131.10	0.91	20.60
2.14	17.86	133.60	0.93	20.99
2.18	18.19	136.10	0.95	21.39
2.22	18.53	138.60	0.96	21.78
2.26	18.86	141.10	0.98	22.17
2.30	19.19	143.60	1.00	22.56

Hydrostatic pressure

$$P_H = 9.81 Z d$$

P_H = hydrostatic pressure (kPa)

Z = vertical depth (m)

d = mud weight (kg/l)

Conversion factors

To convert from	Into	Multiply by
kg/l	lb/gal	8.3452
kg/l	lb/ft ³	62.427
lb/gal	lb/ft ³	7.48082
lb/gal	kg/l	0.11983
lb/ft ³	kg/l	0.016019
lb/ft ³	lb/gal	0.13368
kPa/m	psi/ft	0.044213
psi/ft	kPa/m	22.618

INCREASE OF MUD SPECIFIC GRAVITY WITH BARITE ($d = 4.2$)

Weight (in kg) of barite to add to 1 m³ of mud (M)

Initial mud specific gravity d_1	Desired mud specific gravity d_2																									
	1.05	1.10	1.15	1.20	1.25	1.30	1.35	1.40	1.45	1.50	1.55	1.60	1.65	1.70	1.75	1.80	1.85	1.90	1.95	2.00	2.05	2.10	2.15	2.20	2.25	
1.00	67	135	207	280	356	434	516	600	687	778	872	969	1071	1176	1286	1400	1519	1643	1773	1909	2051	2200	2356	2520	2692	
1.05	68	138	210	285	362	442	525	611	700	792	888	988	1092	1176	1286	1400	1519	1643	1773	1909	2051	2200	2356	2520	2692	
1.10	69	140	214	290	368	450	535	622	713	808	906	1008	1114	1225	1340	1461	1587	1718	1856	1999	2147	2300	2458	2621	2789	
1.15		70	142	217	295	375	458	544	634	727	824	924	1029	1138	1251	1370	1493	1623	1758	1900	2049	2203	2362	2526	2694	
1.20			71	145	221	300	382	467	555	646	741	840	943	1050	1162	1278	1400	1527	1660	1800	1946	2100	2260	2425	2594	
1.25				72	147	225	305	389	475	565	659	756	857	963	1072	1187	1307	1432	1563	1700	1844	1995	2154	2319	2489	
1.30					74	150	229	311	396	485	576	672	771	875	983	1096	1213	1336	1465	1600	1741	1890	2046	2209	2377	
1.35						75	233	317	404	494	585	680	779	883	991	1104	1221	1342	1469	1600	1739	1885	2038	2197	2361	
1.40							238	323	412	504	594	688	786	888	994	1104	1219	1338	1463	1590	1720	1855	1995	2140	2290	
1.45								242	329	420	514	613	715	820	928	1040	1156	1277	1400	1525	1655	1790	1930	2075	2225	
1.50									247	336	429	525	626	730	837	946	1058	1174	1294	1418	1545	1675	1810	1950	2095	
1.55										252	343	438	536	639	744	851	961	1074	1190	1310	1435	1565	1699	1838	1981	
1.60											257	350	447	547	652	759	869	982	1098	1218	1343	1473	1607	1745	1888	
1.65												263	357	457	562	670	780	892	1008	1128	1253	1383	1517	1655	1798	
1.70													268	365	467	574	686	800	916	1036	1161	1291	1425	1563	1706	
1.75														274	373	482	596	712	830	950	1075	1205	1340	1479	1622	
1.80															279	381	492	608	726	846	970	1100	1235	1374	1517	
1.85																285	400	518	638	760	884	1013	1147	1285	1428	
1.90																	408	530	654	780	908	1040	1176	1317	1462	
1.95																		417	541	668	798	930	1065	1205	1350	
2.00																			427	552	684	816	950	1090	1235	
2.05																				437	563	698	832	970	1115	1260
2.10																					447	574	709	845	985	1130
2.15																						457	585	716	850	990
2.20																							467	596	723	855
2.25																								477	607	730

kg x 2.20 = lb m³ x 6.29 = bbl kg/m³ x 0.3505 = lb/bbl

$$M = 4200 \frac{(d_2 - d_1)}{(4.2 - d_2)} \quad (\text{kg/m}^3)$$

INCREASE OF MUD SPECIFIC GRAVITY WITH CALCIUM CARBONATE ($d = 2.65$)

Weight (in kg) of calcium carbonate to add to 1 m³ of mud (M)

Initial mud specific gravity d_1	Desired mud specific gravity d_2														
	1.05	1.10	1.15	1.20	1.25	1.30	1.35	1.40	1.45	1.50	1.55	1.60	1.65	1.70	1.75
1.00	83	171	265	366	473	589	713	848	994	1152	1325	1514	1723	1953	2208
1.05		85	177	274	379	491	612	742	883	1037	1205	1388	1590	1813	2061
1.10			88	183	284	393	510	636	773	922	1084	1262	1458	1674	1914
1.15				91	189	294	408	530	663	807	964	1136	1325	1534	1767
1.20					95	196	306	424	552	691	843	1010	1193	1395	1619
1.25						98	204	318	442	576	723	883	1060	1255	1472
1.30							102	212	331	461	602	757	928	1116	1325
1.35								106	221	346	482	631	795	976	1178
1.40									110	230	361	505	663	837	1031
1.45										115	241	379	530	697	883
1.50											120	252	398	558	736
1.55												126	265	418	589
1.60													133	279	442
1.65														139	294
1.70															147

kg x 2.20 = lb m³ x 6.29 = bbl kg/m³ x 0.3505 = lb/ft³

$$M = 2650 \frac{(d_2 - d_1)}{(2.65 - d_2)} \quad (\text{kg/m}^3)$$

MUD SPECIFIC GRAVITY REDUCTION WITH WATER ($d = 1$)

Water volume in liters to add to 1 m³ of mud (M)

Initial mud specific gravity d_1	Desired mud specific gravity d_2																									
	1.05	1.10	1.15	1.20	1.25	1.30	1.35	1.40	1.45	1.50	1.55	1.60	1.65	1.70	1.75	1.80	1.85	1.90	1.95	2.00	2.05	2.10	2.15	2.20	2.25	
1.10	1 000																									
1.15	2 000	500																								
1.20	3 000	1 000	333																							
1.25	4 000	1 500	667	250																						
1.30	5 000	2 000	1 000	500	200																					
1.35	6 000	2 500	1 333	750	400	167																				
1.40	7 000	3 000	1 667	1 000	600	333	143																			
1.45	8 000	3 500	2 000	1 250	800	500	286	125																		
1.50	9 000	4 000	2 333	1 500	1 000	667	429	250	111																	
1.55	10 000	4 500	2 667	1 750	1 200	833	571	375	222	100																
1.60	11 000	5 000	3 000	2 000	1 400	1 000	714	500	333	200	91															
1.65	12 000	5 500	3 333	2 250	1 600	1 167	857	625	444	300	182	83														
1.70	13 000	6 000	3 667	2 500	1 800	1 333	1 000	750	556	400	273	167	77													
1.75	14 000	6 500	4 000	2 750	2 000	1 500	1 143	875	667	500	364	250	154	71												
1.80	15 000	7 000	4 333	3 000	2 200	1 667	1 286	1 000	778	600	455	333	231	143	67											
1.85	16 000	7 500	4 667	3 250	2 400	1 833	1 429	1 125	889	700	545	417	308	214	133	63										
1.90	17 000	8 000	5 000	3 500	2 600	2 000	1 571	1 250	1 000	800	636	500	385	286	200	125	59									
1.95	18 000	8 500	5 333	3 750	2 800	2 167	1 714	1 375	1 111	900	727	583	462	357	267	188	118	56								
2.00	19 000	9 000	5 667	4 000	3 000	2 333	1 857	1 500	1 222	1 000	818	667	538	429	333	250	176	111	53							
2.05	20 000	9 500	6 000	4 250	3 200	2 500	2 000	1 625	1 333	1 100	909	750	615	500	400	313	235	167	105	50						
2.10	21 000	10 000	6 333	4 500	3 400	2 667	2 143	1 750	1 444	1 200	1 000	833	692	571	467	375	294	222	158	100	48					
2.15	22 000	10 500	6 667	4 750	3 600	2 833	2 286	1 875	1 556	1 300	1 091	917	769	643	533	438	353	278	211	150	95	45				
2.20	23 000	11 000	7 000	5 000	3 800	3 000	2 429	2 000	1 667	1 400	1 182	1 000	846	714	600	500	412	333	263	200	143	91	43			
2.25	24 000	11 500	7 333	5 250	4 000	3 167	2 571	2 125	1 778	1 500	1 273	1 083	923	786	667	563	471	389	316	250	190	136	87	42		
2.30	25 000	12 000	7 667	5 500	4 200	3 333	2 714	2 250	1 889	1 600	1 364	1 167	1 000	857	733	625	529	444	368	300	238	182	130	83	40	

l x 0.264 = gal m³ x 6.29 = bbl l/m³ x 0.042 = gal/bbl

$$M = 1000 \frac{(d_2 - d_1)}{(d_2 - 1)} \quad (\text{liters/m}^3)$$

MUD SPECIFIC GRAVITY REDUCTION WITH OIL (*d* = 0.85)

Oil volume in liters to add to 1 m³ of mud (*M*)

Initial mud specific gravity <i>d</i> ₁	Desired mud specific gravity <i>d</i> ₂																											
	1.05	1.10	1.15	1.20	1.25	1.30	1.35	1.40	1.45	1.50	1.55	1.60	1.65	1.70	1.75	1.80	1.85	1.90	1.95	2.00	2.05	2.10	2.15	2.20	2.25			
1.10	250																											
1.15	500	200																										
1.20	750	400	167																									
1.25	1000	600	333	143																								
1.30	1250	800	500	286	125																							
1.35	1500	1000	667	429	250	111																						
1.40	1750	1200	833	571	375	222	100																					
1.45	2000	1400	1000	714	500	333	200	91																				
1.50	2250	1600	1167	857	625	444	300	182	83																			
1.55	2500	1800	1333	1000	750	556	400	273	167	77																		
1.60	2750	2000	1500	1143	875	667	500	364	250	154	71																	
1.65	3000	2200	1667	1286	1000	778	600	455	333	231	143	67																
1.70	3250	2400	1883	1429	1125	889	700	545	417	308	214	133	63															
1.75	3500	2600	2000	1571	1250	1000	800	636	500	385	286	200	125	59														
1.80	3750	2800	2167	1714	1375	1111	900	727	583	462	357	267	188	118	56													
1.85	4000	3000	2333	1857	1500	1222	1000	818	667	538	429	333	250	176	111	53												
1.90	4250	3200	2500	2000	1625	1333	1100	909	750	615	500	400	313	235	167	105	50											
1.95	4500	3400	2667	2143	1750	1444	1200	1000	833	692	571	467	375	294	222	158	100	48										
2.00	4750	3600	2833	2286	1875	1556	1300	1091	917	769	643	533	438	353	278	211	150	95	45									
2.05	5000	3800	3000	2429	2000	1667	1400	1182	1000	846	714	600	500	412	333	263	200	143	91	43								
2.10	5250	4000	3167	2571	2125	1778	1500	1273	1083	923	786	667	563	471	389	316	250	190	136	87	42							
2.15	5500	4200	3333	2714	2250	1889	1600	1364	1167	1000	857	733	625	529	444	368	300	238	182	130	83	40						
2.20	5750	4400	3500	2857	2375	2000	1700	1455	1250	1077	929	800	688	588	500	421	350	286	227	174	125	80						
2.25	6000	4600	3667	3000	2500	2111	1800	1545	1333	1154	1000	867	750	647	556	474	400	333	273	217	167	120						
2.30	6250	4800	3833	3143	2625	2222	1900	1636	1417	1231	1071	933	813	706	611	526	450	381	318	261	208	160						
																												36

l x 0.264 = gal m³ x 6.29 = bbl l/m³ x 0.042 = gal/bbl

$$M = 1000 \frac{(d_2 - d_1)}{(d_2 - 0.85)} \quad (\text{liters/m}^3)$$

**FINAL VOLUME V_F (IN LITERS)
AFTER ADDING WEIGHTING MATERIAL
OF SPECIFIC GRAVITY d_a TO 1 m³ OF MUD
 M_a weight of weighting material added (kg/m³)**

M_a	d_a 2.75	2.70	2.65	2.60	2.55	2.50	M_a	d_a 4.40	4.35	4.30	4.25	4.20	4.15
50	1018	1019	1019	1019	1020	1020	50	1011	1011	1012	1012	1012	1012
100	1036	1037	1038	1038	1039	1040	100	1023	1023	1023	1024	1024	1024
150	1055	1056	1057	1058	1059	1060	150	1034	1034	1035	1035	1036	1036
200	1073	1074	1075	1077	1078	1080	200	1045	1046	1047	1047	1048	1048
250	1091	1093	1094	1096	1098	1100	250	1057	1057	1058	1059	1060	1060
300	1109	1111	1113	1115	1118	1120	300	1068	1069	1070	1071	1071	1072
350	1127	1130	1132	1135	1137	1140	350	1080	1080	1081	1082	1083	1084
400	1145	1148	1151	1154	1157	1160	400	1091	1092	1093	1094	1095	1096
450	1164	1167	1170	1173	1176	1180	450	1102	1103	1105	1106	1107	1108
500	1182	1185	1189	1192	1196	1200	500	1114	1115	1116	1118	1119	1120
550	1200	1204	1208	1212	1216	1220	550	1125	1126	1128	1129	1131	1133
600	1218	1222	1226	1231	1235	1240	600	1136	1138	1140	1141	1143	1145
650	1236	1241	1245	1250	1255	1260	650	1148	1149	1151	1153	1155	1157
700	1255	1259	1264	1269	1275	1280	700	1159	1161	1163	1165	1167	1169
750	1273	1278	1283	1288	1294	1300	750	1170	1172	1174	1176	1179	1181
800	1291	1296	1302	1308	1314	1320	800	1182	1184	1186	1188	1190	1193
850	1309	1315	1321	1327	1333	1340	850	1193	1195	1198	1200	1202	1205
900	1327	1333	1340	1346	1353	1360	900	1205	1207	1209	1212	1214	1217
950	1345	1352	1358	1365	1373	1380	950	1216	1218	1221	1224	1226	1229
1000	1364	1370	1377	1385	1392	1400	1000	1227	1230	1233	1235	1238	1241
1050	1382	1389	1396	1404	1412	1420	1050	1239	1241	1244	1247	1250	1253
1100	1400	1407	1415	1423	1431	1440	1100	1250	1253	1256	1259	1262	1265
1150	1418	1426	1434	1442	1451	1460	1150	1261	1264	1267	1271	1274	1277
1200	1436	1444	1453	1462	1471	1480	1200	1273	1276	1279	1282	1286	1289
1250	1455	1463	1472	1481	1490	1500	1250	1284	1287	1291	1294	1298	1301
1300	1473	1481	1491	1500	1510	1520	1300	1295	1299	1302	1306	1310	1313
1350	1491	1500	1509	1519	1529	1540	1350	1307	1310	1314	1318	1321	1325
1400	1509	1519	1528	1538	1549	1560	1400	1318	1322	1326	1329	1333	1337
1450	1527	1537	1547	1558	1569	1580	1450	1330	1333	1337	1341	1345	1349
1500	1545	1556	1566	1577	1588	1600	1500	1341	1345	1349	1353	1357	1361
1550	1564	1574	1585	1596	1608	1620	1550	1352	1356	1360	1365	1369	1373
1600	1582	1593	1604	1615	1627	1640	1600	1364	1368	1372	1376	1381	1386
1650	1600	1611	1623	1635	1647	1660	1650	1375	1379	1384	1388	1393	1398
1700	1618	1630	1642	1654	1667	1680	1700	1386	1391	1395	1400	1405	1410
1750	1636	1648	1660	1673	1686	1700	1750	1398	1402	1407	1412	1417	1422
1800	1655	1667	1679	1692	1706	1720	1800	1409	1414	1419	1424	1429	1434
1850	1673	1685	1698	1712	1725	1740	1850	1420	1425	1430	1435	1440	1446
1900	1691	1704	1717	1731	1745	1760	1900	1432	1437	1442	1447	1452	1458
1950	1709	1722	1736	1750	1765	1780	1950	1443	1448	1453	1459	1464	1470
2000	1727	1741	1755	1769	1784	1800	2000	1455	1460	1465	1471	1476	1482

l x 0.00629 = bbl kg x 2.20 = lb

$$V_F = \left(V_I + \frac{M_a}{d_a} \right)$$

- V_F = final volume (l)
- V_I = initial volume = 1000 l
- M_a = weight of weighting material (kg)
- d_a = specific gravity of weighting material

**MUD VOLUME (IN LITERS) REQUIRED TO PREPARE
1 m³ OF MUD WEIGHTED WITH BARITE (d = 4.2)**

Initial mud specific gravity d ₁	Desired mud specific gravity d ₂																								
	1.05	1.10	1.15	1.20	1.25	1.30	1.35	1.40	1.45	1.50	1.55	1.60	1.65	1.70	1.75	1.80	1.85	1.90	1.95	2.00	2.05	2.10	2.15	2.20	2.25
1.00	984	969	953	938	922	906	891	875	859	844	828	813	797	781	766	750	734	719	703	688	672	656	641	625	609
1.05	984	984	968	952	937	921	905	889	873	857	841	825	810	794	778	762	746	730	714	698	683	667	651	635	619
1.10		984	984	968	952	935	919	903	887	871	855	839	823	806	790	774	758	742	726	710	694	677	661	645	629
1.15			984	967	951	934	917	900	883	866	849	832	815	798	781	764	747	730	713	696	679	662	645	628	611
1.20				983	967	950	932	914	896	878	860	842	824	806	788	770	752	734	716	698	680	662	644	626	608
1.25					983	966	948	930	911	892	873	854	835	816	797	778	759	740	721	702	683	664	645	626	607
1.30						983	965	946	927	908	889	870	851	832	813	794	775	756	737	718	699	680	661	642	623
1.35							982	964	945	926	907	888	869	850	831	812	793	774	755	736	717	698	679	660	641
1.40								982	963	944	925	906	887	868	849	830	811	792	773	754	735	716	697	678	659
1.45									981	962	943	924	905	886	867	848	829	810	791	772	753	734	715	696	677
1.50										981	962	943	924	905	886	867	848	829	810	791	772	753	734	715	696
1.55											981	962	943	924	905	886	867	848	829	810	791	772	753	734	715
1.60												981	962	943	924	905	886	867	848	829	810	791	772	753	734
1.65													981	962	943	924	905	886	867	848	829	810	791	772	753
1.70														980	961	941	922	902	882	863	843	824	804	784	765
1.75															980	960	940	920	900	880	860	840	820	800	780
1.80																980	959	939	918	898	878	857	837	816	796
1.85																	979	958	938	917	896	875	854	833	813
1.90																		979	957	936	915	894	872	851	830
1.95																			978	957	935	913	891	870	848
2.00																				978	956	933	911	889	867
2.05																					977	955	932	909	886
2.10																						977	953	930	907
2.15																							976	952	929
2.20																								976	951
2.25																									975

l x 0.00629 = bbl

$$V_1 = V_F \frac{(4.2 - d_2)}{(4.2 - d_1)}$$

V₁ = initial volume of specific gravity d₁
 V_F = final volume of mud d₂
 here V_F = 1000 l

TERNARY DIAGRAM FOR DETERMINING SOLID CONTENT OF MUD (water base muds)

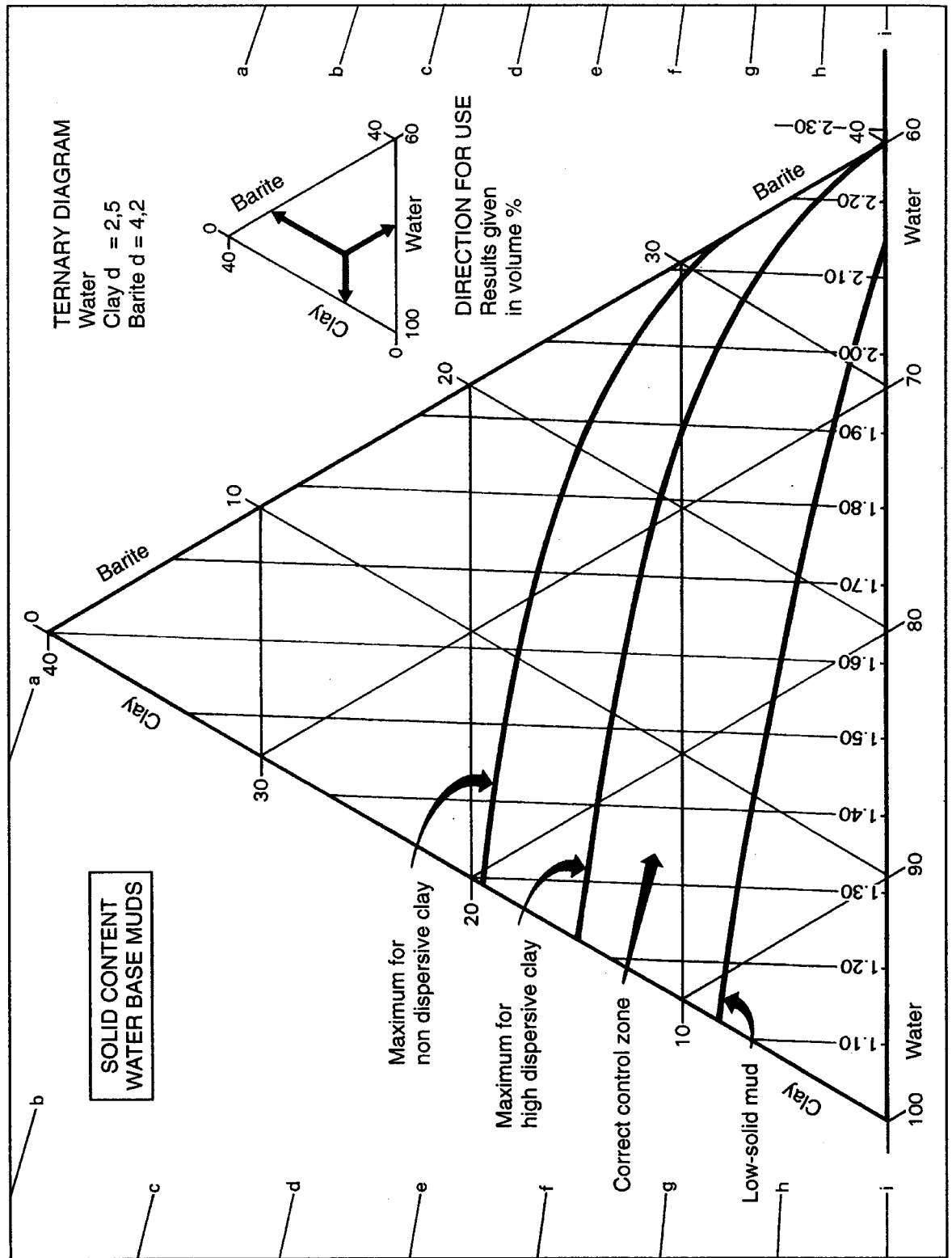

TERNARY DIAGRAM FOR DETERMINING SOLID CONTENT OF MUD (saturated salt water mud)

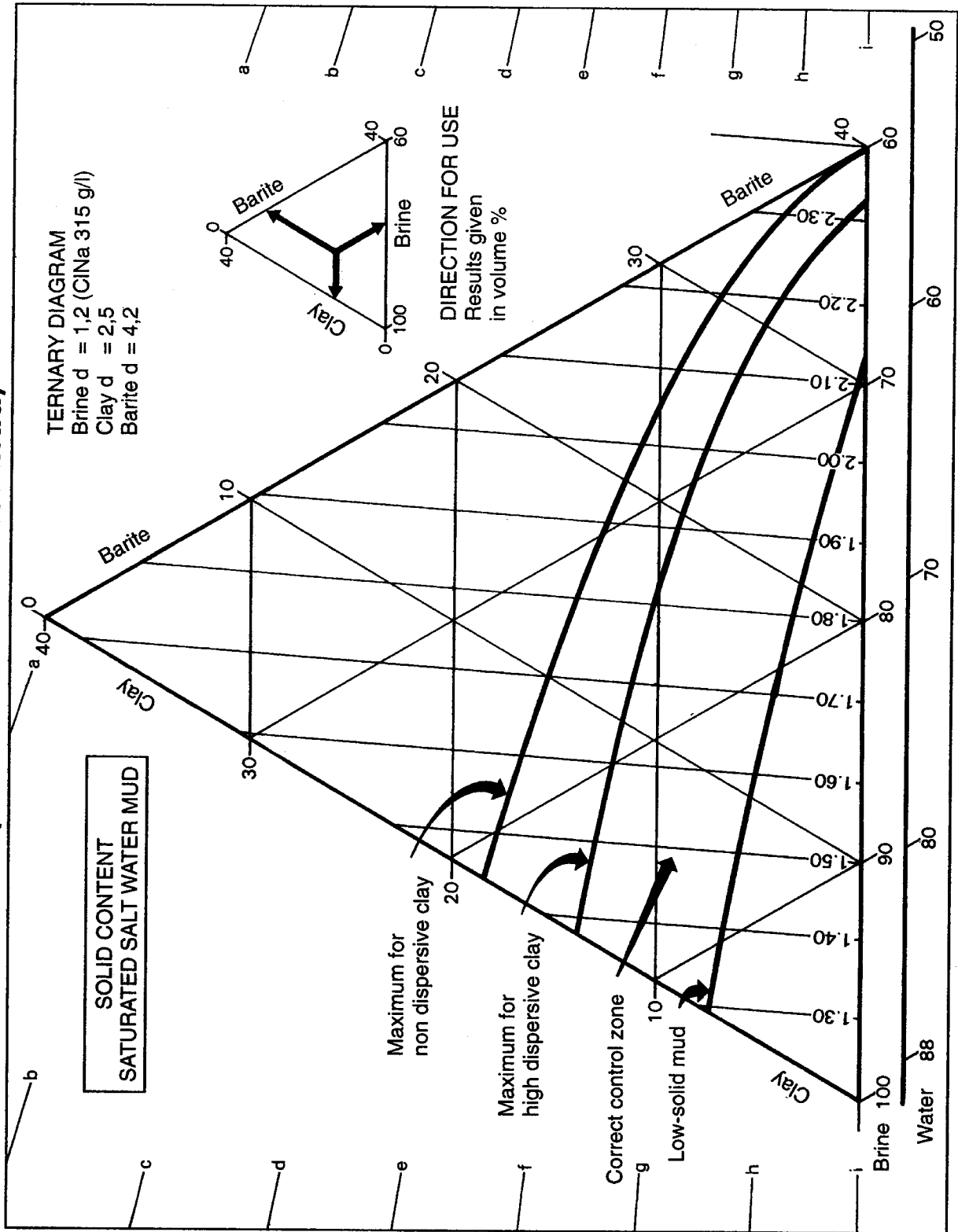

PROPERTIES OF SODIUM CHLORIDE SOLUTIONS

Sp. Gr. at 15.6°C	Solution weight at 15.6°C (kg/m ³)	Materials to prepare 1 m ³ of solution		Freezing point (°C)	Approximate % NaCl
		Salt NaCl (kg)	Freshwater (m ³)		
1.007	1006.3	8.56	0.998	-0.50	1
1.019	1018.3	25.68	0.993	-1.70	3
1.031	1030.3	45.65	0.986	-2.80	4
1.043	1042.3	62.77	0.981	-3.30	6
1.055	1054.2	79.89	0.976	-4.40	7
1.067	1066.2	99.86	0.969	-5.60	9
1.079	1078.2	116.98	0.962	-7.20	11
1.091	1090.2	134.10	0.952	-8.30	12
1.103	1102.2	154.07	0.948	-10.00	14
1.115	1114.1	174.04	0.940	-11.70	15
1.127	1126.1	194.02	0.933	-12.80	17
1.139	1138.1	211.14	0.926	-14.40	18
1.151	1150.1	231.11	0.919	-16.10	20
1.163	1162.1	251.08	0.909	-18.30	21
1.175	1174.0	271.05	0.902	-20.60	23
1.187	1186.0	291.03	0.895	-15.00	24
1.199	1198.0	311.00	0.888	-3.90	26

kg/m³ x 0.00835 = lb/gal kg x 2.20 = lb m³ x 6.29 = bbl

PROPERTIES OF CALCIUM CHLORIDE SOLUTIONS

Sp. Gr. at 15.6°C	Solution weight at 15.6°C (kg/m ³)	Materials to prepare 1 m ³ of solution						Freezing point (°C)	Approximate % anhydrous CaCl ₂
		With a high CaCl ₂ content (94 to 97%)		With a normal CaCl ₂ content (77 to 80%)		Freshwater (m ³)	Freshwater (m ³)		
		CaCl ₂ (kg)	Freshwater (m ³)	CaCl ₂ (kg)	Freshwater (m ³)				
1.007	1006.3	8.56	0.998	11.41	0.995	0.995	-0.56	1	
1.030	1030.3	37.09	0.993	45.65	0.983	0.983	-2.20	3	
1.055	1054.2	68.48	0.988	85.60	0.967	0.967	-3.90	7	
1.079	1078.2	99.86	0.979	122.69	0.950	0.950	-6.10	9	
1.103	1102.2	131.25	0.971	162.63	0.933	0.933	-8.30	11	
1.127	1126.1	165.48	0.962	205.43	0.914	0.914	-11.10	14	
1.151	1150.1	199.72	0.950	245.37	0.895	0.895	-14.40	16	
1.175	1174.0	231.11	0.943	285.32	0.879	0.879	-17.80	19	
1.199	1198.0	268.20	0.931	330.97	0.855	0.855	-22.20	21	
1.223	1222.0	302.44	0.919	373.77	0.833	0.833	-27.80	23	
1.247	1245.9	336.68	0.912	416.57	0.817	0.817	-33.90	26	
1.271	1269.9	370.91	0.900	456.51	0.795	0.795	-41.70	28	
1.295	1293.8	405.15	0.893	499.31	0.779	0.779	-50.60	30	
1.319	1317.8	439.39	0.879	542.11	0.755	0.755	-30.00	32	
1.343	1341.8	476.48	0.864	587.76	0.729	0.729	-17.80	34	
1.367	1365.7	513.57	0.855	633.41	0.709	0.709	-2.78	36	
1.391	1389.7	547.81	0.843	676.21	0.688	0.688	6.67	38	
1.415*	1413.6*	587.76	0.826	724.71	0.659	0.659	15.60	40	
1.439*	1437.6*	630.55	0.809	778.92	0.629	0.629	21.10	42	

* Calculated values, since at 15.6°C, these are not liquids.
 kg/m³ × 0.00835 = lb/gal kg × 2.20 = lb m³ × 6.29 = bbl

PROPERTIES OF POTASSIUM CHLORIDE SOLUTIONS

Sp. Gr. at 15.6°C	Solution weight at 15.6°C (kg/m ³)	Materials to prepare 1 m ³ of solution		Freezing point (°C)	Approximate % KCl
		KCl (kg)	Freshwater (m ³)		
1.005	1002.73	11.4	0.995	-0.56	1
1.011	1009.91	20.0	0.990	-1.1	2
1.024	1021.89	39.9	0.983	-1.7	4
1.037	1035.07	62.8	0.974	-2.8	6
1.050	1048.25	82.8	0.967	-3.3	8
1.063	1061.43	105.6	0.957	-4.4	10
1.077	1074.61	128.4	0.948	-5.6	12
1.091	1088.98	154.1	0.938	-6.7	14
1.104	1102.16	176.9	0.929	-8.3	16
1.119	1116.54	202.6	0.917	-9.4	18
1.133	1130.91	225.4	0.907	-10.6	20
1.147	1134.19	251.1	0.895	1.1	22
1.162	1160.86	279.6	0.883	15.0	24

kg/m³ × 0.00835 = lb/gal kg × 2.20 = lb m³ × 6.29 = bbl

PROPERTIES OF SODIUM CARBONATE (Na₂CO₃) SOLUTIONS

Relative density at 20°C	Specific gravity at 20°C	Solution weight (kg/m ³)	Concentration g/l or kg/m ³	Materials to prepare 1 m ³ of solution				Freezing point (°C)	Approximate % Anhydrous Na ₂ CO ₃
				With anhydrous salt		With hydrated salt			
ρ or D ₄ ²⁰	D ₂₀ ²⁰		C _s	Na ₂ CO ₃ (kg)	Freshwater (m ³)	Na ₂ CO ₃ 10 H ₂ O (kg)	Freshwater (m ³)	Δ	A%
1.009	1.010	1008.6	10.09	10.09	0.999	27.228	0.981	-0.4	1
1.019	1.021	1019.0	20.38	20.38	0.999	55.018	0.964	-0.8	2
1.029	1.031	1029.4	30.88	30.88	0.999	83.370	0.946	-1.1	3
1.040	1.042	1039.8	41.59	41.59	0.998	112.283	0.928	-1.4	4
1.050	1.052	1050.2	52.51	52.51	0.998	141.757	0.908	-1.8	5
1.061	1.063	1060.6	63.64	63.64	0.997	171.793	0.889	-2.1	6
1.071	1.073	1071.1	74.98	74.98	0.996	202.410	0.869		7
1.082	1.084	1081.6	86.53	86.53	0.995	233.593	0.848		8
1.092	1.094	1092.2	98.30	98.30	0.994	265.368	0.827		9
1.103	1.105	1102.9	110.29	110.29	0.993	297.741	0.805		10
1.114	1.116	1113.6	122.50	122.50	0.991	330.693	0.783		11
1.124	1.126	1124.4	134.93	134.93	0.989	364.255	0.760		12
1.135	1.137	1135.3	147.59	147.59	0.988	398.435	0.737		13
1.146	1.148	1146.3	160.48	160.48	0.986	433.241	0.713		14
1.157	1.160	1157.4	173.61	173.61	0.984	468.681	0.689		15

PROPERTIES OF POTASSIUM CARBONATE (K₂CO₃) SOLUTIONS

Relative density at 20°C	Specific gravity at 20°C	Solution weight (kg/m ³)	Concentration g/l or kg/m ³	Materials to prepare 1 m ³ of solution with anhydrous salt		Freezing point (°C)	Approximate % Anhydrous K ₂ CO ₃
				K ₂ CO ₃ (kg)	Freshwater (m ³)		
ρ or D ₄ ²⁰	D ₂₀ ²⁰		C _s			Δ	A %
1.007	1.009	1007	10.1	10.07	0.997	-0.3	1
1.016	1.018	1016	20.3	20.33	0.996	-0.7	2
1.025	1.027	1025	30.8	30.76	0.995	-1.0	3
1.035	1.036	1035	41.4	41.38	0.993	-1.3	4
1.044	1.046	1044	52.2	52.19	0.992	-1.7	5
1.053	1.055	1053	63.2	63.17	0.990	-2.0	6
1.062	1.064	1062	74.4	74.35	0.988	-2.4	7
1.072	1.073	1072	85.7	85.72	0.986	-2.8	8
1.081	1.083	1081	97.3	97.28	0.984	-3.2	9
1.090	1.092	1090	109.0	109.04	0.981	-3.6	10
1.110	1.112	1110	133.1	133.14	0.976	-4.4	12
1.129	1.131	1129	158.1	158.07	0.971	-5.4	14
1.149	1.151	1149	183.8	183.84	0.965	-6.4	16
1.169	1.171	1169	210.5	210.46	0.959	-7.6	18
1.190	1.192	1190	238.0	237.96	0.952	-8.8	20
1.211	1.213	1211	266.4	266.40	0.945		22
1.232	1.234	1232	295.7	295.68	0.936	-12.0	24
1.254	1.241	1254	326.0	325.98	0.928		26
1.276	1.278	1276	357.1	357.14	0.918	-16.0	28
1.298	1.301	1298	389.4	389.39	0.909		30
1.320	1.323	1320	422.5	422.53	0.898	-21.5	32
1.343	1.347	1343	456.8	456.77	0.887		34
1.367	1.369	1367	491.9	491.94	0.875	-28.6	36
1.390	1.393	1390	528.3	528.33	0.862		38
1.414	1.417	1414	565.7	565.68	0.849	-37.6	40
1.439	1.440	1439	604.3	604.28	0.834		42
1.463	1.466	1463	643.9	643.85	0.819		44
1.489	1.491	1489	684.8	684.83	0.804		46
1.514	1.517	1514	726.8	726.82	0.787		48
1.540	1.543	1540	770.2	770.20	0.770		50
1.566	1.569	1566	814.5	814.53	0.752		52

PROPERTIES OF SODIUM BROMIDE (NaBr) SOLUTIONS

Relative density at 20°C ρ or D_{4}^{20}	Specific gravity at 20°C		Solution weight (kg/m ³)	Concentration g/l or kg/m ³ C_s	Materials to prepare 1 m ³ of solution		Freezing point (°C) Δ	Approximate % NaBr A%
	D_{20}^{20}	D_{20}^{20}			NaBr (kg)	Freshwater (m ³)		
1.006	1.008	1.008	1006	10.1	10.06	0.996	-0.3	1
1.014	1.016	1.016	1014	20.3	20.28	0.994	-0.7	2
1.022	1.024	1.024	1022	30.7	30.65	0.991	-1.0	3
1.030	1.032	1.032	1030	41.2	41.19	0.989	-1.4	4
1.038	1.040	1.040	1038	51.9	51.90	0.986	-1.8	5
1.046	1.048	1.048	1046	62.8	62.77	0.983	-2.1	6
1.055	1.056	1.056	1055	73.8	73.82	0.981	-2.5	7
1.063	1.065	1.065	1063	85.0	85.04	0.978	-2.9	8
1.072	1.074	1.074	1072	96.4	96.44	0.975	-3.3	9
1.080	1.082	1.082	1080	108.0	108.03	0.972	-3.8	10
1.089	1.091	1.091	1089	119.8	119.81	0.969	-4.2	11
1.098	1.100	1.100	1098	131.8	131.77	0.966	-4.7	12
1.107	1.109	1.109	1107	143.9	143.94	0.963	-5.2	13
1.116	1.118	1.118	1116	156.3	153.30	0.960	-5.7	14
1.126	1.128	1.128	1126	168.9	168.86	0.957	-6.2	15
1.135	1.137	1.137	1135	181.6	181.63	0.954	-6.7	16
1.145	1.147	1.147	1145	194.6	194.62	0.950	-7.3	17
1.155	1.157	1.157	1155	207.8	207.83	0.947		18
1.165	1.167	1.167	1165	221.3	221.26	0.943		19
1.175	1.177	1.177	1175	234.9	234.90	0.940		20
1.185	1.187	1.187	1185	248.8	248.81	0.936		21
1.195	1.197	1.197	1195	262.9	262.92	0.932		22

**EFFECT OF TEMPERATURE ON DENSITIES OF CALCIUM CHLORIDE AND SODIUM CHLORIDE SOLUTIONS
(Field Data Handbook, Dowell Schlumberger)**

As the temperature of the solution rises, the volume increases with a resulting decrease in density. The change in density of these solutions can be readily calculated by the formula:

$$\text{Density change} = 0.647 (T_1 - T_2) \quad (\text{kg/m}^3)$$

T_1 = initial temperature (°C)

T_2 = desired temperature (°C)

Example of application

For example, if the average well temperature is 80°C, and an average solution density of 1300 kg/m³ is required at 15°C.

$$\begin{aligned} \text{Density change (kg/m}^3) &= 0.647 (80 - 15) \\ &= 42.06 \text{ kg/m}^3 \end{aligned}$$

$$\begin{aligned} \text{Required solution density at 15}^\circ\text{C} &= 1300 + 42.06 \\ &= 1342.06 \text{ kg/m}^3 \text{ at 15}^\circ\text{C} \end{aligned}$$

GRAIN SIZE CLASSIFICATION OF SOLIDS ($1\mu = 0.000001 \text{ m}$)

Some examples of solid sizes:

	(μ)
Human hair	30 to 200
Pollen	10 to 100
Powdered cement	3 to 100
Flour	1 to 80
Talc	5 to 50
Make-up powder	35

French definition for classification of solids:

	(μ)
Coarse sand	> 200
Fine sand	20 to
Silt	200
Coarse clay	10 to 20
Fine clay	2 to 10
Colloidal clay	0.2 to 2 < 0.2

American definition in API 13C:

	(μ)
Coarse	> 2000
Intermediate	2000 to 250
Medium	250 to 74
Fine	74 to 44
Ultra fine	44 to 2
Colloidal	< 2

In drilling, another classification has been adopted:

	(μ)
Sand	> 74
Silt	2 to 74
Colloid	< 2

SHALE SHAKER SCREENS

Mesh/in	Wire diameter		Width of opening V		T	API designation
	(in)	(10 ⁻³ mm)	(in)	(10 ⁻³ mm)	Approximate open area (%)	
8 × 8	0.028	711	0.097	2464	60.2	8 × 8 (2464 × 2464. 60.2)
10 × 10	0.025	635	0.075	1905	56.3	10 × 10 (1905 × 1905. 56.3)
12 × 12	0.023	584	0.060	1524	51.8	12 × 12 (1524 × 1524. 51.8)
14 × 14	0.020	508	0.051	1295	51.0	14 × 14 (1295 × 1295. 51.0)
16 × 16	0.018	457	0.0445	1130	50.7	16 × 16 (1130 × 1130. 50.7)
18 × 18	0.018	457	0.0376	955	45.8	18 × 18 (955 × 955. 45.8)
20 × 20	0.017	432	0.033	838	43.6	20 × 20 (838 × 838. 43.6)
8 × 20	0.032/0.020	813/508	0.093/0.030	2362/762	45.7	8 × 20 (2362 × 762. 45.7)
20 × 30	0.015	381	0.035/0.0183	889/465	39.5	20 × 30 (889 × 465. 39.5)
30 × 30	0.012	305	0.0213	541	40.8	30 × 30 (541 × 541. 40.8)
30 × 40	0.010	254	0.0233/0.015	592/381	42.5	30 × 40 (592 × 381. 36.0)
40 × 36	0.010	254	0.015/0.0178	381/452	40.5	40 × 36 (381 × 452. 40.5)
40 × 40	0.010	254	0.015	381	36.0	40 × 40 (381 × 381. 36.0)
50 × 40	0.0085	216	0.0115/0.0165	292/419	38.3	50 × 40 (292 × 419. 38.3)
50 × 50	0.009	229	0.011	279	30.3	50 × 50 279 × 279. 30.3)
60 × 40	0.009	229	0.0077/0.016	200/406	31.1	60 × 40 (200 × 406. 31.1)
60 × 60	0.0075	191	0.0092	234	30.5	60 × 60 234 × 234. 30.5)
70 × 30	0.0075	191	0.007/0.026	178/660	40.3	70 × 30 (178 × 660. 40.3)
80 × 80	0.0055	140	0.007	178	31.4	80 × 80 (178 × 178. 31.4)
100 × 100	0.0045	114	0.0055	140	30.3	100 × 100 (140 × 140. 30.3)
120 × 120	0.0037	94	0.0046	117	30.9	120 × 120 (117 × 117. 30.9)

For a square mesh

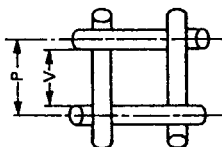

$$T(\%) = \frac{(\text{open area})^2}{(\text{pitch})^2} \times 100 = \frac{V^2}{P^2} \times 100$$

SCREEN STANDARDS

France		Germany	Great Britain		Italy	Russian		USA				Wenworth and J. Boucart scale	
Afnor Association Française de Normalisation		Deutsche Normen	British Standards Institution		Unificazione Italiano			The WS TYLER Cleveland 14 Ohio	American Society for Testing Materials				
NF X 11-501 1970		DIN 4100 1957	BS-410 1943		UNI 2332 1943	COST-3584-53 1953		The TYLER Standard Screen Scale Sieves	ASTM E 11-61 1961				
Opening (mm)	Module	Opening (mm)	Opening (mm)	Designation number (No.)	Opening (mm)	Opening (mm)	Designation number (No.)	Opening (mm)	Designation number (mesh)	Opening (mm)	Designation number (No.)		
0.04	17	0.04	0.044	350	0.04	0.04	4	0.038	400 +	0.037	400	Silt. loess 4 to 62.5 μ	
0.05	18	0.045			0.05	0.045	45	5	0.043	325	0.044		325
0.063	19	0.05			0.056	56	0.053	270	0.053	270 +	0.053		270 +
								0.061	250	0.063	230		
0.08	20	0.071	0.076	200	0.075	0.071	71	0.074	200 +	0.074	200 +	Very fine sand 62.5 to 125 μ	
		0.08	0.089	170	0.08	0.08	8	0.088	170 +	0.088	170		
0.1	21	0.09	0.104	150	0.09	0.09	9	0.104	150 +	0.105	140 +		
		0.1			0.106	112	0.112						112
0.125	22	0.125	0.124	120	0.125	0.125	125	0.124	115	0.125	120		
						0.14	14						
0.16	23	0.16	0.152	100	0.15	0.16	16	0.147	100 +	0.149	100 +	Fine sand 125 to 250 μ	
			0.178	85	0.16		18	0.175	80 +	0.177	80		
			0.211	72	0.18		2	0.208	65 +	0.21	70		
0.25	25	0.25	0.251	60	0.2	0.2	2	0.208	65 +	0.21	70		
					0.212	0.224	224	0.246	60	0.25	60 +		
					0.25	0.25	25						
					0.28	0.28	28						
0.315	26	0.315	0.295	52	0.3	0.355	355	0.295	48 +	0.297	50 +	Medium sand 0.25 to 0.5 mm	
			0.353	44	0.315			4	0.351	42	0.354		45
			0.422	36	0.355			4	0.417	35 +	0.42		40 +
0.5	28	0.5	0.5	30	0.4	0.4	4	0.417	35 +	0.42	40 +		
					0.425	0.45	45	0.495	32	0.5	35		
					0.5	0.5	5						
0.63	29	0.63	0.599	25	0.6	0.56	56	0.589	28 +	0.595	30 +	Coarse sand 0.5 to 1 mm	
			0.63	22	0.63	63	0.63	7	0.701	24	0.707		25
			0.699		0.71	7	0.7						
0.8	30	0.8	0.853	18	0.75	0.8	8	0.833	20 +	0.841	20 +		
					0.8	0.8	8	0.991	16	100	18		
1	31	1	1.003	16	0.85	0.9	9						
					1	1	1						
1.25	32	1.25	1.204	14	1.18	1.25	1.25	1.168	14 +	1.19	16	Very coarse sand 1 to 2 mm	
			1.405	12	1.25			14.4	1.397	12	1.41		14
			1.676	10	1.6			1.6	1.651	10 +	1.68		12 +
1.6	33	1.6	2.057	8	1.7	2	2	1.981	9	2	10		
2	34	2			2	2	2						
2.5	35	2.5	2.411	7	2.36	2.5	2.5	2.362	8 +	2.38	8	Granulated material 2 to 4 mm	
			2.812	6	2.5			2.8	2.794	7	2.83		7
			3.353	5	3.15			3.35	3.327	6 +	3.36		6 +
3.15	36	3.15			4	3.962	5	4	5				
4	37	4			4	4	4	4.699	4 +	4.76	4		
5	38	5						5.613	312	5.66	312		

mm x 0.0394 = in

AIR/GAS FLOW RATE REQUIRED FOR DRILLING

Data for calculating approximate circulation rates required to produce a minimum annular velocity which is equivalent in lifting power to a standard air velocity of 914 m/min (3000 ft/h)

$$Q = Q_o + (NH)$$

Q = flow rate required (m³/min)

Q_o = initial flow rate (m³/min) (tables)

N = (tables)

H = depth (100 m) (330 ft)

Hole size		Drill pipe size		Air				Gas $d = 0.60$					
				Q_o	Values of N				Q_o	Values of N			
(in)	(mm)	(in)	(mm)		ROP					ROP			
					Rate of penetration (m/h)					Rate of penetration (m/h)			
					0	10	20	30		0	10	20	30
17 1/2	445	6 5/8	168	119.18	0.764	1.250	1.719	2.160	153.87	0.616	1.243	1.821	2.357
		5 1/2	140	125.38	0.741	1.216	1.667	2.085	161.86	0.574	1.158	1.711	2.263
15	381	4 1/2	114	129.92	0.725	1.184	1.614	2.020	167.75	0.539	1.096	1.619	2.124
		6 5/8	168	82.26	0.666	1.074	1.470	1.833	106.22	0.596	1.142	1.635	2.098
		5 1/2	140	91.01	0.638	1.027	1.389	1.742	114.20	0.544	1.043	1.507	1.938
12 1/4	311	4 1/2	114	93.02	0.613	0.989	1.335	1.669	120.09	0.502	0.983	1.411	1.829
		6 5/8	168	48.14	0.579	0.94	1.258	1.559	62.13	0.585	1.082	1.509	1.910
		5 1/2	140	54.31	0.538	0.861	1.151	1.423	70.14	0.523	0.942	1.332	1.682
11	279	4 1/2	114	58.87	0.514	0.801	1.074	1.321	76.00	0.472	0.853	1.207	1.540
		6 5/8	168	35.03	0.563	0.906	1.201	1.467	45.22	0.599	1.075	1.472	1.837
		5 1/2	140	41.23	0.509	0.803	1.066	1.312	53.24	0.516	0.940	1.268	1.594
9 7/8	251	4 1/2	114	45.76	0.470	0.737	0.977	1.208	59.10	0.465	0.814	1.126	1.431
		5 1/2	140	30.55	0.492	0.769	1.007	1.229	39.45	0.524	0.912	1.239	1.530
		5	127	32.93	0.467	0.723	0.952	1.164	42.53	0.486	0.846	1.156	1.434
9	229	4 1/2	114	35.11	0.444	0.685	0.902	1.105	45.31	0.453	0.785	1.074	1.348
		5	127	25.43	0.456	0.697	0.911	1.096	32.85	0.492	0.836	1.119	1.372
		4 1/2	114	27.61	0.428	0.653	0.853	1.042	35.62	0.455	0.769	1.047	1.281
8 3/4	222	3 1/2	89	31.23	0.386	0.582	0.764	0.926	40.32	0.390	0.666	0.907	1.118
		5	127	23.43	0.455	0.696	0.897	1.084	30.24	0.497	0.835	1.113	1.360
		4 1/2	114	25.57	0.427	0.650	0.843	1.018	33.02	0.456	0.768	1.062	1.266
7 7/8	200	3 1/2	89	29.22	0.379	0.572	0.746	0.905	37.72	0.388	0.658	0.893	1.112
		4 1/2	114	18.97	0.415	0.620	0.795	0.952	24.49	0.465	0.756	1.004	1.211
		3 1/2	89	22.60	0.364	0.540	0.700	0.842	29.19	0.386	0.636	0.850	1.039
7 3/8	187	3 1/2	89	19.14	0.358	0.524	0.669	0.802	24.72	0.386	0.624	0.827	1.014
6 3/4	171	3 1/2	89	15.15	0.347	0.503	0.634	0.753	19.54	0.386	0.611	0.794	0.962
6 1/4	159	3 1/2	89	12.18	0.344	0.488	0.613	0.721	15.72	0.390	0.602	0.742	0.917
		2 7/8	73	13.99	0.305	0.438	0.450	0.652	18.07	0.344	0.532	0.687	0.824
		2 7/8	73	6.48	0.294	0.391	0.472	0.540	8.38	0.344	0.487	0.599	0.691
4 3/4	121	2 3/8	60	7.67	0.258	0.352	0.427	0.493	9.91	0.300	0.432	0.538	0.628

m³/min × 35.3 = ft³/min m/h × 3.28 = ft/h

Example : 8 3/4 in hole, 5 in drill pipes, depth 7900 ft

ROP = 10 m/h

$$Q = 23.43 + 24 \times 0.696 = 40.13 \text{ m}^3/\text{min}$$

Sources : R.R. Angel, Phillips Petroleum Co., AIME Paper 873 – G, *AIME Petroleum Transactions*, vol. 210, 1957.



cementing

General data units commonly used in cementing.....	I1
Correlation between sacks and tons of cement.....	I2
API cement classes and types (API Spec 10, 5 th edition, July 1, 1990).....	I3
API Specifications for cements (API Spec 10, 5 th edition, July 1, 1990).....	I4
Preparation of freshwater slurry.....	I5
Cement slurry (freshwater).....	I6
Preparation of one cubic meter of freshwater cement slurry.....	I7
Preparation of salt water slurry (Brine 315 g/l, $d = 1.20$).....	I8
Cement slurry (saturated salt-water), (Brine 315 g/l, $d = 1.20$).....	I9
Preparation of one cubic meter of saturated salt-water slurry.....	I10
Preparation of bentonite cements.....	I11-I12
Bentonite cement slurry. Class G (per 100 kg of cement).....	I13
Preparation of one cubic meter of bentonite cement slurry - Class G cement.....	I14

Preparation of weighted cements.....	I15
Cementing additives.....	I16-I18
Effects of some additives on cement properties.....	I19
Slurry displacement.....	I20-I21
Bottomhole cementing temperature by depth (API RP 10B, 22 nd edition, December, 1997).....	I22

GENERAL DATA UNITS COMMONLY USED IN CEMENTING

Packaging

1 sack of cement (USA)	{	94 lb
		42.64 kg
Cement volume in one sack of 94 lb	{	1 cu ft
		28.32 liters
(Hence a silo of x cu ft contains x sacks)		
Net weight of one 50 kg sack of cement	{	49.5 kg
		109 lb
Cement volume in one 50 kg sack	{	32.89 liters
		1.16 cu ft

Weight

1 short ton	=	{	2000 lb
			907 kg
			21.28 sacks of 94 lb
			18.33 sacks of 50 kg
1 metric ton	=	{	2205 lb
			23.45 sacks of 94 lb
			1.10 short ton
			0.984 long ton
1 short ton	=	{	2240 lb
			1016 kg
			23.83 sacks of 94 lb
			20.53 sacks of 50 kg

Volume

1 cubic foot	=	28.32 liters	1 barrel	=	0.159 m ³
1 US gallon	=	3.785 liters	1 barrel	=	5.61 cu ft

Density

1 kg/l	=	8.345 lb/gal	1 lb/gal	=	7.48 lb/ft ³
1 kg/l	=	62.428 lb/ft ³	1 lb/ft ³	=	0.01602 kg/l
1 lb/gal	=	0.1198 kg/l	1 lb/ft ³	=	0.1337 lb/gal

Cement specific gravity

True density of powdered cement	3.15
Apparent density of powdered cement	1.5
True volume occupied by 1 kg of powdered cement (liters)	0.3175

CORRELATION BETWEEN SACKS AND TONS OF CEMENT

94 lb sacks

Sacks	Metric tons 2205 lb 1000 kg	Short tons 2000 lb 907 kg	Long tons 2240 lb 1016 kg
100	4.26	4.70	4.20
120	5.12	5.64	5.04
140	5.97	6.58	5.87
160	6.82	7.52	6.71
180	7.68	8.46	7.55
200	8.53	9.40	8.39
220	9.38	10.34	9.23
240	10.23	11.28	10.07
260	11.09	12.22	10.91
280	11.94	13.16	11.75
300	12.79	14.10	12.59
320	13.64	15.04	13.43
340	14.50	15.98	14.27
360	15.35	16.92	15.11
380	16.20	17.86	15.95
400	17.06	18.80	16.79
420	17.91	19.74	17.62
440	18.76	20.68	18.46
460	19.61	21.62	19.30
480	20.47	22.56	20.14
500	21.32	23.50	20.98
520	22.17	24.44	21.82
540	23.03	25.38	22.66
560	23.88	26.32	23.50
580	24.73	27.26	24.34
600	25.58	28.20	25.18
620	26.44	29.14	26.02
640	27.29	30.08	26.86
660	28.14	31.02	27.70
680	29.00	31.95	28.54
700	29.85	32.89	29.37
720	30.70	33.83	30.21
740	31.55	34.77	31.05
760	32.41	35.71	31.89
780	33.26	36.65	32.73
800	34.11	37.59	33.57
820	34.96	38.53	34.41
840	35.82	39.47	35.25
860	36.67	40.41	36.09
880	37.52	41.35	36.93
900	38.38	42.29	37.77
920	39.23	43.23	38.61
940	40.08	44.17	39.45
960	40.93	45.11	40.29
980	41.79	46.05	41.12

50 kg sacks

Sacks	Metric tons 2205 lb 1000 kg	Short tons 2000 lb 907 kg	Long tons 2240 lb 1016 kg
100	4.95	5.46	4.87
120	5.94	6.55	5.85
140	6.93	7.63	6.82
160	7.92	8.72	7.79
180	8.91	9.81	8.77
200	9.90	10.90	9.74
220	10.89	11.99	10.72
240	11.88	13.08	11.69
260	12.87	14.17	12.67
280	13.86	15.26	13.64
300	14.85	16.35	14.62
320	15.84	17.44	15.59
340	16.83	18.53	16.56
360	17.82	19.62	17.54
380	18.81	20.71	18.51
400	19.80	21.80	19.49
420	20.79	22.89	20.46
440	21.78	23.98	21.44
460	22.77	25.07	22.41
480	23.76	26.16	23.38
500	24.75	27.25	24.36
520	25.74	28.34	25.33
540	26.73	29.43	26.31
560	27.72	30.52	27.28
580	28.71	31.61	28.26
600	29.70	32.70	29.23
620	30.69	33.79	30.21
640	31.68	34.88	31.18
660	32.67	35.97	32.15
680	33.66	37.06	33.13
700	34.65	38.15	34.10
720	35.64	39.24	35.08
740	36.63	40.33	36.05
760	37.62	41.42	37.03
780	38.61	42.51	38.00
800	39.60	43.60	38.97
820	40.59	44.69	39.95
840	41.58	45.78	40.92
860	42.57	46.87	41.90
880	43.56	47.96	42.87
900	44.55	49.05	43.85
920	45.54	50.14	44.82
940	46.53	51.23	45.80
960	47.52	52.32	46.77
980	48.51	53.41	47.74

API CEMENT CLASSES AND TYPES (API Spec 10, 5th edition, July 1, 1990)

Class	Type
A	For use from surface to 1830 m (6000 ft) depth, when special properties are not required. Available only in ordinary type.
B	For use from surface to 1830 m (6000 ft) depth, when conditions require moderate to high sulfate-resistance. Available in both moderate and high sulfate-resistant types.
C	For use from surface to 1830 m (6000 ft) depth, when conditions require high early strength. Available in ordinary and moderate and high sulfate-resistant types.
D	For use from 1830 m (6000 ft) to 3050 m (10 000 ft) depth, under conditions of moderately high temperatures and pressures. Available in both moderate and high sulfate-resistant types.
E	For use from 3050 m (10 000 ft) to 4270 m (14 000 ft) depth, under conditions of high temperature sand pressures. Available in both moderate and high sulfate-resistant types.
F	For use from 3050 m (10 000 ft) to 4880 m (16 000 ft) depth, under conditions of extremely high temperatures and pressures. Available in both moderate and high sulfate-resistant types.
G	For use as a basic well cement from surface to 2440 m (8000 ft) depth as manufactured, or can be used with accelerators and retarders to cover a wide range of well depths and temperatures. No additions other than calcium sulfate or water, or both, shall be inter-ground or blended with the clinker during manufacture of Class G well cement. Available in moderate and high sulfate-resistant types.
H	For use as a basic well cement from surface to 2440 m (8000 ft) depth as manufactured, or can be used with accelerators and retarders to cover a wide range of well depths and temperatures. No additions other than calcium sulfate or water, or both, shall be inter-ground or blended with the clinker during manufacture of Class H well cement. Available in moderate and high sulfate-resistant types.

Notes: For details concerning the chemical composition of the different classes of API cement, refer to API Spec 10.

API SPECIFICATIONS FOR CEMENTS (API Spec 10, 5th edition, July 1, 1990)

Class	Maximum depth		Minimum thickening time (min) according to API 10 tests	Compressive strength (kPa and psi) according to API Spec 10 tests Table 7.2						Mixing water				
				Curing temperature and pressure		After 8 h curing time		After 24 h curing time		% by weight of cement	Per 42.5 kg (94 lb) sack		Per 50 kg (100 lb) sack	
	T (°C)	P (kPa)		(kPa)	(psi)	(kPa)	(psi)	(liters)	(gal)		(liters)	(gal)		
A	0-1 830	0-6 000	at 305 m: 90 at 1 830 m: 90	38	atm	1 700	250	12 400	1 800	46	19.6	5.19	23	6.07
B	0-1 830	0-6 000	at 305 m: 90 at 1 830 m: 90	38	atm	1 400	200	10 300	1 500	46	19.6	5.19	23	6.07
C	0-1 830	0-6 000	at 305 m: 90 at 1 830 m: 90	38	atm	2 100	300	13 800	2 000	56	23.9	6.32	28	7.39
D	1 830-3 050	6 000-10 000	at 1 830 m: 90 at 3 050 m: 100	77 110	20 700 20 700	3 500	500	6 900 13 800	1 000 2 000	38	16.2	4.29	19	5.02
E	3 050-4 270	10 000-14 000	at 3 050 m: 100 at 4 270 m: 154	77 143	20 700 20 700	3 500	500	6 900 13 800	1 000 2 000	38	16.2	4.29	19	5.02
F	3 050-4 880	10 000-16 000	at 3 050 m: 100 at 4 880 m: 190	110 160	20 700 20 700	3 500	500	6 900 6 900	1 000 1 000	38	16.2	4.29	19	5.02
G	0-2 440	0-8 000	at 2 440: 90 max 120	38 60	atm atm	2 100 10 300	300 1 500			44	18.8	4.97	22	5.81
H	0-2 440	0-8 000	at 2 440: 90 max 120	38 60	atm atm	2 100 10 300	300 1 500			38	16.2	4.29	19	5.02

Remarks:

The addition of bentonite to cement requires an increase in the amount of water. For testing purpose, 5.3% water should be added for each 1% of bentonite in all API cement classes. For example, for class A or B cement slurry containing 4% bentonite, the water/cement ratio must be raised from 46% to 67.2% ($46 + 4 \times 5.3 = 46 + 21.2 = 67.2$). The addition of barite to cement requires an increase in the amount of water by 0.2% for each 1% of barite added for all cement classes. For example, for 60% barite added, the water/cement ratio must be raised from 38% to 50% for a class D, E, F or G cement.

PREPARATION OF FRESHWATER SLURRY

Rule of the thumb:

$$1 \text{ sack} \begin{cases} 94 \text{ lb} \\ 1 \text{ cu ft} \end{cases} + 5 \text{ gal water} \Rightarrow \text{cement with } d = 1.90$$

$$\text{Slurry density} = \frac{\text{Cement mass} + \text{Water mass}}{\text{Cement volume} + \text{Water volume}} = \frac{\text{Total mass}}{\text{Slurry volume}}$$

For 100 kg of cement:

- Slurry specific gravity:

$$d = \frac{100 + e}{\frac{100}{3.15} + e}$$

- Water volume (in liters):

$$e = \frac{100 \left(1 - \frac{d}{3.15}\right)}{d - 1}$$

Class of cement	Volume of water (liters) for 100 kg of cement	Specific gravity obtained
A	46	1.88
B	46	1.88
C	56	1.78
D	38	1.98
E	38	1.98
F	38	1.98
G	44	1.90
H	38	1.98

- Slurry yield (in liters):

$$v = \frac{100}{3.15} + e$$

$$v = \frac{68.3}{d - 1}$$

Example: 100 kg of cement + 44 liters of water gives:

$$\text{slurry specific gravity: } d = \frac{100 + 44}{\frac{100}{3.15} + 44} = \frac{144}{31.8 + 44} = \frac{144}{75.8} = 1.90$$

and slurry yield:

$$v = 75.9 \text{ liters}$$

CEMENT SLURRY (FRESHWATER)

	Slurry density				Freshwater volume						Slurry volume					
	(kg/l)	(lb/gal)	(lb/ft ³)	(l/100 kg)	(gal/94 lb sack)	(ft ³ /94 lb sack)	(l/94 lb sack)	(l/sh ton)	(gal/sh ton)	(ft ³ /sh ton)	(l/100 kg)	(l/94 lb sack)	(ft ³ /94 lb sack)	(l/sh ton)	(ft ³ /sh ton)	
	1.74	14.5	108.6	60.5	6.81	0.91	25.8	549	145.0	19.38	92.2	39.3	1.39	837	29.55	
	1.75	14.6	109.2	59.3	6.67	0.89	25.3	538	142.0	18.98	91.0	38.8	1.37	826	29.16	
	1.76	14.7	109.9	58.1	6.54	0.87	24.8	527	139.1	18.60	89.8	38.3	1.35	815	28.77	
	1.77	14.8	110.5	56.9	6.41	0.86	24.3	516	136.4	18.23	88.6	37.8	1.33	804	28.40	
Class C	1.78	14.9	111.1	55.8	6.28	0.84	23.8	506	133.6	17.86	87.5	37.3	1.32	794	28.03	
	1.79	14.9	111.7	54.7	6.16	0.82	23.3	496	131.0	17.51	86.4	36.8	1.30	784	27.68	
	1.80	15.0	112.4	53.6	6.03	0.81	22.8	486	128.4	17.16	85.3	36.4	1.28	774	27.33	
	1.81	15.1	113.0	52.5	5.92	0.79	22.4	476	125.9	16.83	84.3	35.9	1.27	764	27.00	
	1.82	15.2	113.6	51.5	5.80	0.78	22.0	467	123.4	16.50	83.2	35.5	1.25	755	26.67	
	1.83	15.3	114.2	50.5	5.69	0.76	21.5	458	121.0	16.17	82.2	35.1	1.24	746	26.35	
	1.84	15.4	114.9	49.5	5.58	0.75	21.1	449	118.7	15.86	81.3	34.6	1.22	737	26.03	
	1.85	15.4	115.5	48.6	5.47	0.73	20.7	440	116.4	15.55	80.3	34.2	1.21	728	25.73	
	1.86	15.5	116.1	47.6	5.36	0.72	20.3	432	114.1	15.26	79.4	33.8	1.20	720	25.43	
	1.87	15.6	116.7	46.7	5.26	0.70	19.9	424	111.9	14.96	78.5	33.5	1.18	712	25.13	
Class A, B	1.88	15.7	117.4	45.8	5.16	0.69	19.5	416	109.8	14.68	77.6	33.1	1.17	704	24.85	
	1.89	15.8	118.0	44.9	5.06	0.68	19.2	408	107.7	14.40	76.7	32.7	1.15	696	24.57	
Class G	1.90	15.9	118.6	44.1	4.97	0.66	18.8	400	105.7	14.13	75.8	32.3	1.14	688	24.30	
	1.91	15.9	119.2	43.3	4.87	0.65	18.4	392	103.7	13.86	75.0	32.0	1.13	680	24.03	
	1.92	16.0	119.9	42.4	4.78	0.64	18.1	385	101.7	13.60	74.2	31.6	1.12	673	23.77	
	1.93	16.1	120.5	41.6	4.69	0.63	17.8	378	99.8	13.34	73.4	31.3	1.11	666	23.51	
	1.94	16.2	121.1	40.9	4.60	0.62	17.4	371	97.9	13.09	72.6	31.0	1.09	659	23.26	
	1.95	16.3	121.7	40.1	4.52	0.60	17.1	364	96.1	12.85	71.8	30.6	1.08	652	23.02	
	1.96	16.4	122.4	39.4	4.43	0.59	16.8	357	94.3	12.61	71.1	30.3	1.07	645	22.78	
	1.97	16.4	123.0	38.6	4.35	0.58	16.5	350	92.6	12.37	70.4	30.0	1.06	638	22.54	
Class D, E, F	1.98	16.5	123.6	37.9	4.27	0.57	16.2	344	90.8	12.14	69.6	29.7	1.05	632	22.31	
	1.99	16.6	124.2	37.2	4.19	0.56	15.9	337	89.1	11.92	68.9	29.4	1.04	625	22.09	
	2.00	16.7	124.9	36.5	4.11	0.55	15.6	331	87.5	11.70	68.3	29.1	1.03	619	21.87	
	2.01	16.8	125.5	35.8	4.04	0.54	15.3	325	85.9	11.48	67.6	28.8	1.02	613	21.65	
	2.02	16.9	126.1	35.2	3.96	0.53	15.0	319	84.3	11.27	66.9	28.5	1.01	607	21.44	
	2.03	16.9	126.7	34.5	3.89	0.52	14.7	313	82.7	11.06	66.3	28.3	1.00	601	21.23	
	2.04	17.0	127.4	33.9	3.82	0.51	14.4	307	81.2	10.86	65.6	28.0	0.99	595	21.03	
	2.05	17.1	128.0	33.3	3.75	0.50	14.2	302	79.7	10.65	65.0	27.7	0.98	590	20.83	
	2.06	17.2	128.6	32.6	3.68	0.49	13.9	296	78.2	10.46	64.4	27.5	0.97	584	20.63	
	2.07	17.3	129.2	32.0	3.61	0.48	13.7	291	76.8	10.27	63.8	27.2	0.96	579	20.44	
	2.08	17.4	129.9	31.5	3.54	0.47	13.4	285	75.4	10.08	63.2	26.9	0.95	573	20.25	
	2.09	17.4	130.5	30.9	3.48	0.46	13.2	280	74.0	9.89	62.6	26.7	0.94	568	20.06	
	2.10	17.5	131.1	30.3	3.41	0.46	12.9	275	72.6	9.71	62.0	26.5	0.93	563	19.88	

Note: When using the same volume of sea-water instead of freshwater, the slurry specific gravity is increased by 0.01 on the average.
 Example: a sea-water cement slurry with a water/cement ratio of 45 liters/100 kg has a slurry density of 1.90 kg/l instead of 1.89 kg/l as shown in the table for freshwater.

PREPARATION OF ONE CUBIC METER OF FRESHWATER CEMENT SLURRY

	Slurry specific gravity	Cement weight		Water volume (liters)
		(kg)	(94 lb sacks)	
	1.75	1099	25.8	651
	1.76	1113	26.1	647
	1.77	1128	26.5	642
Class C	1.78	1143	26.8	637
	1.79	1157	27.1	633
	1.80	1172	27.5	628
	1.81	1187	27.8	623
	1.82	1201	28.2	619
	1.83	1216	28.5	614
	1.84	1231	28.9	609
	1.85	1245	29.2	605
	1.86	1260	29.5	600
	1.87	1275	29.9	595
Class A, B	1.88	1289	30.2	591
	1.89	1304	30.6	586
Class G	1.90	1319	30.9	581
	1.91	1333	31.3	577
	1.92	1348	31.6	572
	1.93	1363	32.0	567
	1.94	1377	32.3	563
	1.95	1392	32.6	558
	1.96	1407	33.0	553
	1.97	1421	33.3	549
Class D, E, F	1.98	1436	33.7	544
	1.99	1450	34.0	540
	2.00	1465	34.4	535
	2.01	1480	34.7	530
	2.02	1494	35.0	526
	2.03	1509	35.4	521
	2.04	1524	35.7	516
	2.05	1538	36.1	512
	2.06	1553	36.4	507
	2.07	1568	36.8	502
	2.08	1582	37.1	498
	2.09	1597	37.5	493
	2.10	1612	37.8	488

$m^3 \times 264 = gal$ $m^3 \times 35.3 = cu\ ft$ $l \times 0.264 = gal$ $l \times 0.0353 = cu\ ft$

PREPARATION OF SALT WATER SLURRY (Brine 315 g/l, $d = 1.20$)

$$\text{Slurry density} = \frac{\text{Cement mass} + \text{Brine mass}}{\text{Cement volume} + \text{Brine volume}}$$

$$\text{Brine mass (kg)} = 1.20 \times \text{brine volume (liters)}$$

For 100 kg of cement:

- Slurry specific gravity:

$$d = \frac{100 + 1.20 e}{\frac{100}{3.15} + e}$$

where:

d = slurry specific gravity

e = brine volume in liters

- Water volume (in liters):

$$e = \frac{100 \left(1 - \frac{d}{3.15}\right)}{d - 1.20}$$

- Slurry yield (in liters):

$$v = \frac{100}{3.15} + e$$

$$v = \frac{61.9}{d - 1.20}$$

Example: 100 kg of cement + 46 liters of water gives:

$$\text{slurry specific gravity: } d = \frac{100 + 1.20 \times 46}{\frac{100}{3.15} + 46} = \frac{155.2}{31.8 + 46} = \frac{155.2}{77.8} = 2.00$$

and slurry yield:

$$v = 77.4 \text{ liters}$$

CEMENT SLURRY (SATURATED SALT-WATER) (Brine 315 g/l, d = 1.20)

Slurry density			Brine volume						Slurry volume					
(kg/l)	(lb/gal)	(lb/ft ³)	(l/100 kg)	(gal/94 lb sack)	(ft ³ /94 lb sack)	(l/94 lb sack)	(l/sh ton)	(gal/sh ton)	(ft ³ /sh ton)	(l/100 kg)	(l/94 lb sack)	(ft ³ /94 lb sack)	(l/sh ton)	(ft ³ /sh ton)
1.80	15.0	112.4	71.4	8.05	1.08	30.5	648	171.2	22.88	103.2	44.0	1.55	936	33.05
1.81	15.1	113.0	69.7	7.86	1.05	29.7	633	167.1	22.34	101.5	43.3	1.53	921	32.51
1.82	15.2	113.6	68.1	7.67	1.03	29.0	618	163.2	21.82	99.8	42.6	1.50	906	31.99
1.83	15.3	114.2	66.5	7.49	1.00	28.4	603	159.4	21.31	98.3	41.9	1.48	891	31.48
1.84	15.4	114.9	65.0	7.32	0.98	27.7	589	155.7	20.82	96.7	41.2	1.46	877	30.99
1.85	15.4	115.5	63.5	7.15	0.96	27.1	576	152.2	20.34	95.2	40.6	1.43	864	30.51
1.86	15.5	116.1	62.0	6.99	0.93	26.5	563	148.7	19.88	93.8	40.0	1.41	851	30.05
1.87	15.6	116.7	60.6	6.83	0.91	25.9	550	145.4	19.43	92.4	39.4	1.39	838	29.60
1.88	15.7	117.4	59.3	6.68	0.89	25.3	538	142.1	18.99	91.0	38.8	1.37	826	29.17
1.89	15.8	118.0	58.0	6.53	0.87	24.7	526	138.9	18.57	89.7	38.3	1.35	814	28.74
1.90	15.9	118.6	56.7	6.39	0.85	24.2	514	135.9	18.16	88.4	37.7	1.33	802	28.33
1.91	15.9	119.2	55.4	6.25	0.83	23.6	503	132.9	17.76	87.2	37.2	1.31	791	27.93
1.92	16.0	119.9	54.2	6.11	0.82	23.1	492	130.0	17.37	86.0	36.7	1.29	780	27.55
1.93	16.1	120.5	53.1	5.98	0.80	22.6	481	127.2	17.00	84.8	36.2	1.28	769	27.17
1.94	16.2	121.1	51.9	5.85	0.78	22.1	471	124.4	16.63	83.7	35.7	1.26	759	26.80
1.95	16.3	121.7	50.8	5.72	0.76	21.7	461	121.7	16.27	82.5	35.2	1.24	749	26.44
1.96	16.4	122.4	49.7	5.60	0.75	21.2	451	119.1	15.92	81.5	34.7	1.23	739	26.10
1.97	16.4	123.0	48.6	5.48	0.73	20.7	441	116.6	15.59	80.4	34.3	1.21	729	25.76
1.98	16.5	123.6	47.6	5.36	0.72	20.3	432	114.1	15.26	79.4	33.8	1.20	720	25.43
1.99	16.6	124.2	46.6	5.25	0.70	19.9	423	111.7	14.93	78.4	33.4	1.18	711	25.10
2.00	16.7	124.9	45.6	5.14	0.69	19.5	414	109.4	14.62	77.4	33.0	1.17	702	24.79
2.01	16.8	125.5	44.7	5.03	0.67	19.1	405	107.1	14.31	76.4	32.6	1.15	693	24.48
2.02	16.9	126.1	43.7	4.93	0.66	18.7	397	104.8	14.02	75.5	32.2	1.14	685	24.19
2.03	16.9	126.7	42.8	4.83	0.65	18.3	389	102.7	13.72	74.6	31.8	1.12	677	23.89
2.04	17.0	127.4	42.0	4.73	0.63	17.9	381	100.5	13.44	73.7	31.4	1.11	669	23.61
2.05	17.1	128.0	41.1	4.63	0.62	17.5	373	98.5	13.16	72.8	31.1	1.10	661	23.33
2.06	17.2	128.6	40.2	4.53	0.61	17.2	365	96.4	12.89	72.0	30.7	1.08	653	23.06
2.07	17.3	129.2	39.4	4.44	0.59	16.8	358	94.4	12.63	71.2	30.3	1.07	646	22.80
2.08	17.4	129.9	38.6	4.35	0.58	16.5	350	92.5	12.37	70.3	30.0	1.06	638	22.54
2.09	17.4	130.5	37.8	4.26	0.57	16.1	343	90.6	12.11	69.6	29.7	1.05	631	22.28
2.10	17.5	131.1	37.0	4.17	0.56	15.8	336	88.8	11.87	68.8	29.3	1.04	624	22.04
2.11	17.6	131.7	36.3	4.09	0.55	15.5	329	87.0	11.62	68.0	29.0	1.02	617	21.79
2.12	17.7	132.3	35.5	4.00	0.54	15.2	322	85.2	11.39	67.3	28.7	1.01	610	21.56
2.13	17.8	133.0	34.8	3.92	0.52	14.8	316	83.4	11.15	66.6	28.4	1.00	604	21.33
2.14	17.9	133.6	34.1	3.84	0.51	14.5	309	81.7	10.93	65.9	28.1	0.99	597	21.10
2.15	17.9	134.2	33.4	3.76	0.50	14.2	303	80.1	10.71	65.2	27.8	0.98	591	20.88
2.16	18.0	134.8	32.7	3.69	0.49	14.0	297	78.5	10.49	64.5	27.5	0.97	585	20.66

PREPARATION OF ONE CUBIC METER OF SATURATED SALT-WATER SLURRY

Slurry specific gravity	Cement weight		Water volume (liters)
	(kg)	(94 lb sacks)	
1.75	888	20.8	718
1.76	905	21.2	713
1.77	921	21.6	708
1.78	937	22.0	703
1.79	953	22.4	697
1.80	969	22.7	692
1.81	985	23.1	687
1.82	1002	23.5	682
1.83	1018	23.9	677
1.84	1034	24.2	672
1.85	1050	24.6	667
1.86	1066	25.0	662
1.87	1082	25.4	656
1.88	1098	25.8	651
1.89	1115	26.1	646
1.90	1131	26.5	641
1.91	1147	26.9	636
1.92	1163	27.3	631
1.93	1179	27.7	626
1.94	1195	28.0	621
1.95	1212	28.4	615
1.96	1228	28.8	610
1.97	1244	29.2	605
1.98	1260	29.5	600
1.99	1276	29.9	595
2.00	1292	30.3	590
2.01	1308	30.7	585
2.02	1325	31.1	579
2.03	1341	31.4	574
2.04	1357	31.8	569
2.05	1373	32.2	564
2.06	1389	32.6	559
2.07	1405	33.0	554
2.08	1422	33.3	549
2.09	1438	33.7	544
2.10	1454	34.1	538
2.11	1470	34.5	533
2.12	1486	34.9	528
2.13	1502	35.2	523
2.14	1518	35.6	518
2.15	1535	36.0	513
2.16	1551	36.4	508

$\text{m}^3 \times 264 = \text{gal}$
 $\text{m}^3 \times 35.3 = \text{cu ft}$
 $\text{l} \times 0.264 = \text{gal}$
 $\text{l} \times 0.0353 = \text{cu ft}$

PREPARATION OF BENTONITE CEMENTS

To prepare a lightweight cement with freshwater, bentonite (1) can be added:

(a) **Dry** to the cement in proportions ranging between 1 and 20% to obtain a slurry specific gravity between 1.85 and 1.42 (for Class G)

(b) Or **prehydrated** in proportions ranging between 0.25 and 5% to obtain a slurry specific gravity between 1.84 and 1.39 (also for Class G):

$$\text{Slurry density} = \frac{\text{Cement mass} + \text{Water mass} + \text{Bentonite mass}}{\text{Cement volume} + \text{Water volume} + \text{Bentonite volume}}$$

For 100 kg of cement:

- Slurry specific gravity:

$$d = \frac{100 + e + (Z+1)b}{\frac{100}{3.15} + e + \left(Z + \frac{1}{2.65}\right)b}$$

where:

d = bentonite slurry specific gravity

b = percentage of bentonite in relation to cement (or weight of bentonite per 100 kg of cement)

In general $0 < b < 20$ if **dry mixture**

$0 < b < 5$ if **prehydrated mixture**

e = volume of cement hydration water in relation to cement:

Class of cement	Volume of water (liters) for 100 kg of cement
A	46
B	46
C	56
D	38
E	38
F	38
G	44
H	38

Z = percentage of bentonite swelling water in relation to bentonite
(or liters of water per kg of bentonite)

$Z = 5.3$ for bentonite added dry

$Z = 21.2$ for prehydrated bentonite

The specific gravity of bentonite is taken as 2.65.

(1) Attapulgite ($d = 2.89$) is used with sea-water.

PREPARATION OF BENTONITE CEMENTS (continued)

- Bentonite weight (in kg):

$$b = \frac{100 \left(1 - \frac{d}{3.15} \right) - (d-1)e}{d \left(\frac{1}{2.65} + Z \right) - (Z+1)}$$

- Water volume (in liters):

$$E = e + Zb$$

- Slurry volume (in liters):

$$v = \frac{100}{3.15} + \frac{b}{2.65} + e + Zb$$

Example: to prepare a slurry with prehydrated bentonite and Class G cement, with specific gravity $d = 1.50$:

$$d = 1.50$$

$$e = 44 \text{ liters}$$

$$Z = 21.2$$

the calculation (or table I 13) gives $b = 3\%$

For 100 kg of cement:

3 kg of bentonite

107.6 liters of water

140.5 liters of slurry

BENTONITE CEMENT SLURRY

Class G (per 100 kg of cement)

Prehydrated mixture

(21.2 liters of water/kg bentonite)

% of bentonite	Volume water (l)	Specific gravity
0.00	44.0	1.901
0.25	49.3	1.843
0.50	54.6	1.792
0.75	59.9	1.748
1.00	65.2	1.708
1.25	70.5	1.672
1.50	75.8	1.640
1.75	81.1	1.611
2.00	86.4	1.585
2.25	91.7	1.560
2.50	97.0	1.538
2.75	102.3	1.518
3.00	107.6	1.499
3.25	112.9	1.482
3.50	118.2	1.466
3.75	123.5	1.451
4.00	128.8	1.437

Dry mixture

(5.3 liters of water/kg bentonite)

% of bentonite	Volume water (l)	Specific gravity
0	44.0	1.901
1	49.3	1.846
2	54.6	1.798
3	59.9	1.756
4	65.2	1.719
5	70.5	1.685
6	75.8	1.656
7	81.1	1.629
8 (1)	86.4	1.604
9	91.7	1.582
10	97.0	1.562
11	102.3	1.543
12	107.6	1.526
13	112.9	1.511
14	118.2	1.496
15	123.5	1.482
16	128.8	1.470
17	134.1	1.458
18	139.4	1.447
19	144.7	1.436
20	150.0	1.426

(1) For 8% and higher, it is advisable to add a thinner.

PREPARATION OF ONE CUBIC METER OF BENTONITE CEMENT SLURRY – CLASS G CEMENT

Prehydrated mixture

% bentonite	Cement (kg)	Bentonite (kg)	Water volume (l)	Specific gravity
0.00	1320	0.00	581	1.901
0.25	1232	3.08	608	1.843
0.50	1156	5.78	631	1.792
0.75	1088	8.16	652	1.748
1.00	1028	10.28	670	1.708
1.25	974	12.17	686	1.672
1.50	925	13.87	701	1.640
1.75	881	15.42	714	1.611
2.00	841	16.82	727	1.585
2.25	805	18.10	738	1.560
2.50	771	19.28	748	1.538
2.75	740	20.36	757	1.518
3.00	712	21.36	766	1.499
3.25	686	22.28	774	1.482
3.50	661	23.14	781	1.466
3.75	638	23.94	788	1.451
4.00	617	24.68	795	1.437

Dry mixture

% bentonite	Cement (kg)	Bentonite (kg)	Water volume (l)	Specific gravity
0	1320	0.00	581	1.901
1	1228	12.28	605	1.846
2	1148	22.96	627	1.798
3	1078	32.34	646	1.756
4	1016	40.63	662	1.719
5	960	48.02	677	1.685
6	911	54.64	690	1.656
7	866	60.61	702	1.629
8	825	66.03	713	1.604
9	788	70.95	723	1.582
10	755	75.46	732	1.562
11	724	79.60	740	1.543
12	695	83.41	748	1.526
13	669	86.93	755	1.511
14	644	90.19	761	1.496
15	621	93.22	768	1.482
16	600	96.05	773	1.470
17	581	98.69	778	1.458
18	562	101.16	783	1.447
19	545	103.48	788	1.436
20	528	105.66	792	1.426

kg × 0.0235 = sack l × 0.264 = gal l × 0.0353 = cu ft

PREPARATION OF WEIGHTED CEMENTS

For 100 kg of cement:

- Slurry specific gravity:

$$d = \frac{100 + e + a}{\frac{100}{3.15} + e + \frac{a}{d_a}}$$

where:

e = water volume (in liters)

a = weight of heavy weight additive (in kg)

d_a = heavy weight additive specific gravity

- Specific gravity of some heavy weight additives:

Barite: 4.20 – 4.33

Ilmenite: 4.45

Hematite: 4.95

- Specific gravity obtained:

Specific gravity	2.10	2.20	2.30	2.40	2.50	2.60	2.70
Barite (% BWOC)	40	87	110				
Water (% BWOC)*	48	60	58				
Dispersant (% BWOC)			1				
Ilmenite (% BWOC)		30	55				
Water (% BWOC)		38	41				
Hematite (% BWOC)		40	60	80	110	150	175
Water (% BWOC)		44	46	46	50	55	55
Dispersant (% BWOC)				0.3	0.5	0.8	1.0

* 44% BWOC water + 0.20 l water /kg barite

Dispersant: CD-31 (BJ Services), D65 (Dowell) – CFR2 (Halliburton) or similar

Example: for 100 kg of cement:

87 kg of barite

60 liters of water

$$d = \frac{100 + 60 + 87}{\frac{100}{3.15} + 60 + \frac{87}{4.20}}$$

$$d = 2.20$$

CEMENTING ADDITIVES

Application	Description	BJ Services	Dowell	Halliburton
Accelerators	Sodium chloride Calcium chloride Sodium silicate Gypsum Potassium chloride	A5 A7 (A7L) A2/Diacel A (A3L) A10 A9	D44 S1 (D77) D79/D75 D53 M117	Salt Cacl ₂ (Cacl ₂ liq) Econolite Cal-seat/EA2 Kcl
Extenders and density-reducing agents	Bentonite Attapulgite Type F flyash Type C flyash Natural pozzolan Diatomaceous earth Perlite Fumed silica Glass microspheres Pozzolan microspheres Proprietary extender	Bentonite Attapulgite Flyash Flyash Pozzolan Diacel D Perlite BA58 (BA58L - LW8L) LW7-2/LW7-4 LW-6 T40/FWC47 (BJ BLUE)	D20 D128 D35 D132 D61 D56 D72 D154 (D155) D124 (D111)	Gel Attapulgite Pozmix A Class C flyash Diacel D Perlite Silicate (Microblock) Glass spheres Spherelite VersaSet (verSaset L)
Retarders	Temperature < 180°F Temperature 125°F to 225°F Temperature 175°F to 300°F Temperature > 225°F Temperature > 300°F Aid for lignosulfonates Synthetic < 250°F Synthetic < 425°F For improved comp. strength For thixotropic cement Permafrost non lignosulfonate Permafrost lignosulfonate	R3 (R21L) R3 (R10L/R12L/R21L) R6/Diacel LWL R8 (R8L) R9 SR30 (R14/R15LS/R20L) SR30 (R14/R15LS/R20L) R18/SR30 R7	D13 (D81) D800 (D801) D8 (D110) D28 (D150) D93/D121 D161 (D110) D74 D13 (D81)	HR4/HR7 (HR4L/HR7L) HR5 (HR6L) Diacel LWL HR12/HR15 (HR12L/HR15L) HR20 Comp R/HR25 SCR100 (SCR100L) HR25 (HR25L) SCR100 (SCR100L) Sodium citrate HR4 (HR4L)

() liquid additive.

CEMENTING ADDITIVES (continued)

Application	Description	BJ Services	Dowell	Halliburton
Fluid loss additive	Fresh water 60°F to 120°F	FL62 (BA10L)	D127/D156	LAP1 (LA2)
	Salt (<10%) 60°F to 120°F			
	Salt (<18%) 60°F to 120°F	FL33/FL63 (FL33L/FL63L)	D146	Halad 322/344/413 (L)
	Fresh water 80°F to 200°F	FL62 (BA10L)	(D300)	LAP1/Halad 447 (LA2)
	Salt (<10%) 80°F to 200°F		D60	(Halad 10L)
	Salt (<18%) 80°F to 200°F		D59	Halad 9/322 (9L/322L)
	Salt (>18%) 80°F to 200°F			
	Fresh water <250°F	FL62 (FL62L)		
	Salt (<10%) <250°F		D160 (D603/D159)	Halad 22A/344 (22AL)
	Salt (<18%) <250°F		D65A (D80A/D604AM)	
Salt (>18%) <250°F				
Fresh water <300°F				
Salt (<10%) <300°F				
Salt (<18%) <300°F				
Salt (>18%) <300°F				
Fresh water >300°F				
Salt (<10%) >300°F				
Salt (<18%) >300°F				
Salt (>18%) >300°F				
Cement dispersant	General application	FL25/FL52	(D73/D73.1/D158)	Halad 14 (14LXP/600LE+)
	Salt-saturated slurries		D8/D143 (D158)	
	Dispersant with anti-settling	FL33/FL63 (FL33L/FL63L)		Halad 413/100A (413L/361A)
Loss circulation additives	General application	CD31/CD32 (CD31L/CD32L)	D65/D121 (D80/D145A)	CFR2/CFR3 (CFR2L/CFR3L)
	Salt-saturated slurries	XR2	D45/D65A (D80A/D604AM)	FE2/CFR2 (CFR2L)
	Dispersant with anti-settling	CD32 (CD32L)	(D604AM)	CFR2 (CFR2L)
	Gilsonite	Gilsonite	D24	Gilsonite
Cellophane flake	Celloflake	D29	Flocele	
Ground coal	Kol Seal	D42		
Walnut plug	Nut Plug			Tuf Plug
Polyester, thermoplastic	Flex Seal/Mud Save			Granulite TR1/4
Graded particule sizes	Kwik Seal		D130	Kwik Seal

() liquid additive.

CEMENTING ADDITIVES (continued)

Application	Description	BJ Services	Dowell	Halliburton
Heavy weight additives	Sand 100 mesh Silica flour Barite Hematite Ilmenite Manganese Oxides Calcium carbonate	S8C S8 Barite Hematite Ilmenite W10	D30 D66 D31 D76 D18 D157 D151	SSA2 SSA1 Barite Hi-dense 3/Hi-dense 4 Micromax
Anti-foam agents	Decrease foaming	FP 11 (FP 6L/9L/10L/12L)	D46 (D47/M45/D144)	D-Air1 (D-Air2/3 /NF1/2/3)
Free water control	Polymers, sodium silicates	A2 /DiaceI A/T40 (A3L/T40L)	D79/DiaceI A/D153 (D75/D162)	Econolite/DiaceI A/VersaSet
Bond improving expanding additives and anti-gas migration	Latex Fumed silica Expanding agent Gas-generating agents	BA10/BA58 (BA10L/BA86L) BA58/CSE (BA58L) A10/EC1 BA29/BA61	(D600/D134) D154 (D155) D53	Latex 2000 (LA2) Silicalite (Microblock) Cal-Seal/EA2/Microbond Super CBL (Gas-Chek)
Spacer and washes	No weighted chemical washes OBM chemical washes Spacer aqueous Spacer emulsion Spacer OBM Spacer high salt concentration	Flowcheck/Flo Guard Mud Clean/MRS2 Mud Sweep/Ultraflush II MCS 2/3/4/5 Ultraflush II APS1/OB1/RSB MCS 3/4/RSB	ZoneIock/ZoneIock SC CW7/CW8/CW8ES CW100/CW101 CW8/CW8ES/CW101 MUDPUSH XT/XTO/XS/XSO/XL MUDPUSH XEO MUDPUSH XLO/XTO/XEO MUDPUSH XS	Superflush Mud Flush Aqua Preflush N-Ver-Sperse/Alpha Preflush Dual Spacer/SD Spacer Dual/Alpha Spacer Dual Spacer/Dual Spacer E
Specialty cement blends	Thixotropic cements Silica flume and pozzolan Lightweight pozzolan micros. Permafrost	Sure Fill Cenolite Cold Set	RFC HILITE LITEFIL ARTICSET	Thix Set 31 My-T-Lite 2000 PERMAFROST

() liquid additive.

EFFECTS OF SOME ADDITIVES ON CEMENT PROPERTIES (1)

		Bentonite	Perlite	Diatomaceous earth	Pozzolan	Sand	Barite	Hematite	Calcium chloride	Sodium chloride	Lignosulfonate	CMHEC (2)	Diesel oil	Water loss additives	Lost circulation material
Density	Decreased	●	●	●	●										
	Increased					●	●	●	X	X	X				
Water required	Decreased										●				
	Increased	●	X	●	X	X	X	X							X
Viscosity	Decreased								X		●				
	Increased	X	X	X	X	X	X	X							
Thickening time	Accelerated	X					X	X	●	●					
	Retarded			X						X	●	●	X	X	
Setting time	Accelerated						X	X	●	●					
	Retarded	X	X	X	X						●	●		X	
Early strength	Decreased	X	X	X	X		X	X			●	●		X	X
	Increased								●	●					
Final strength	Decreased	X	X	●	X		X					X		X	X
	Increased														
Duration	Decreased	X	X	X									X		X
	Increased				●										
Water loss	Decreased	●									X	●	X	●	X
	Increased		X	X											

- (1) From Dowell Schlumberger Engineer's Handbook
 x Denotes minor effect
 ● Denotes major effect and/or purpose of additive
 (2) Carboxymethyl hydroxyethyl cellulose

SLURRY DISPLACEMENT

Calculation of displacement volume corresponding to the time when the fluids in the annulus and the fluids in the casing reach hydrostatic equilibrium:

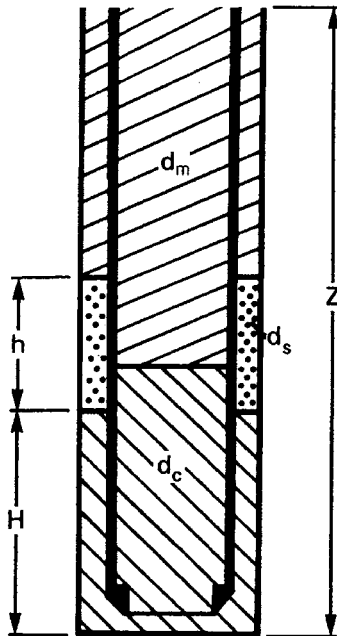

- V_s = spacer volume at specific gravity d_s
- V_c = cement volume at specific gravity d_c
- V = displacement volume at specific gravity d_m at time of equilibrium
- a = volume per meter in casing
- b = volume per meter in annulus
- h = spacer height in annulus in meters
- H = cement height in annulus at equilibrium in meters
- Z = casing setting depth in meters

$$h = \frac{V_s}{b} \quad (1)$$

$$H = \frac{V_c}{b+a} - \frac{a}{b(b+a)} V_s \frac{d_s - d_m}{d_c - d_m} \quad (2)$$

$$V = \left(Z - \frac{V_c}{b+a} - \frac{V_s}{b+a} \frac{d_s - d_m}{d_c - d_m} \right) a \quad (3)$$

SLURRY DISPLACEMENT (continued)

Specific case without spacer:

$$V = \left(Z - \frac{V_c}{b+a} \right) a$$

Cementing with two slurries: Formula (1), (2) and (3) can be used for a cement gel instead of a spacer, provided that, at the time of equilibrium, the cement gel, like the spacer, is already in the annulus.

Calculation example:

$Z = 3000$ m

Hole size: 12 1/4 in

Casing 9 5/8 in 47 lb/ft

$(a = 38.18$ l/m)

$(b = 28.94$ l/m)

Spacer volume:

$V_s = 5\ 000$ liters

Spacer specific gravity:

$d_s = 1.50$

Cement volume:

$V_c = 50\ 000$ liters

Cement specific gravity:

$d_c = 1.90$

Mud specific gravity:

$d_m = 1.10$

Results:

$h = 173$ m

$H = 696$ m

$V = 85$ m³

The displacement volume corresponding to the time when the fluids in the annulus and the fluids in the casing reach hydrostatic equilibrium is 85 m³.

BOTTOMHOLE CEMENTING TEMPERATURE BY DEPTH (API RP 10B, 22nd edition, December, 1997)

Well depth		Temp (°C)	Temperature gradient °C/100 m					
(m)	(ft)		1.6	2.0	2.4	2.7	3.1	3.5
300	1 000	BHCT	27	27	27	27	27	27
		BHLT	32	33	34	35	36	37
610	2 000	BHCT	32	32	32	32	33	33
		BHLT	37	39	41	43	46	48
1 220	4 000	BHCT	37	38	38	39	39	40
		BHLT	47	51	56	60	64	69
1 830	6 000	BHCT	44	46	47	48	49	52
		BHLT	57	63	70	77	83	90
2 440	8 000	BHCT	52	54	57	60	63	71
		BHLT	67	76	84	93	102	111
3 050	10 000	BHCT	61	63	70	75	82	93
		BHLT	77	88	99	110	121	132
3 660	12 000	BHCT	64	74	84	94	104	113
		BHLT	87	100	113	127	140	153
4 270	14 000	BHCT	73	85	97	109	121	133
		BHLT	97	112	128	143	159	174
4 880	16 000	BHCT	83	97	112	126	140	154
		BHLT	107	124	142	160	178	196
5 490	18 000	BHCT	94	111	127	144	161	177
		BHLT	117	137	157	177	197	217
6 100	20 000	BHCT	106	124	144	163	182	202
		BHLT	127	149	171	193	216	238
6 710	22 000	BHCT	118	140	162	184	207	229
		BHLT	137	161	186	210	234	259

BHCT = Bottom Hole Circulating Temperature
 BHLT = Bottom Hole Log Temperature after 24 hours

$$^{\circ}\text{F} = 1.8^{\circ}\text{C} + 32$$

J

directional drilling

Reference coordinates.....	J1-J2
Radius of curvature and project in the vertical plane.....	J3
Calculation of characteristic points of the theoretical vertical profile. <i>J</i> hole : $D < R$	J4-J5
Calculation of characteristic points of the theoretical vertical profile. <i>J</i> hole : $D > R$	J6-J7
Calculation of characteristic points of the theoretical vertical profile. <i>S</i> hole : $R_1 + R_2 < D$	J8-J9
Calculation of characteristic points of the theoretical vertical profile. <i>S</i> hole : $R_1 + R_2 > D$	J10-J11
Theoretical vertical profile. Rate of buildup: 0.50 deg/10 m.....	J12
Theoretical vertical profile (continued). Rate of buildup: 1.00 deg/10 m.....	J13
Theoretical vertical profile (continued). Rate of buildup: 1.50 deg/10 m.....	J14
Theoretical vertical profile (continued). Rate of buildup: 2.00 deg/10 m.....	J15
Theoretical vertical profile (continued). Rate of buildup: 2.50 deg/10 m.....	J16
Ragland diagram.....	J17-J18
Control of actual hole shape. Calculation of projections.....	J19

Control of actual hole shape. Different calculation formulas.....	J20-J21
Course correction.....	J22-J23
Radius of borehole curvature limitation on downhole tools.....	J24-J25

REFERENCE COORDINATES

AZIMUTH

Azimuths measured in holes refer to one of the following:

- (a) **True geographic North** (meridian direction): this is the direction of the geographic North Pole. The direction is shown on maps by the meridians of longitude.
- (b) **Magnetic North** (compass direction): the compass initially gives a reading referenced to magnetic North. The position of this point is subject to time variation.
- (c) **Grid North** (Lambert or UTM North): the surface of the Earth is a curved surface but the maps are flat surfaces.

They are measured positively clockwise from:

- (a) 0 to 360 degrees
- (b) 0 to 400 grades

The system of quadrants still used in certain measuring instruments refers, depending on the direction, to North or South, from 0 to 90 degrees to East or West.

Example: Azimuth 227 degrees is equivalent to S47W or 47SW.

DECLINATION

The declination is the angle between local magnetic North and geographic North (local meridian) measured positively eastward.

CONVERGENCE

Convergence is the angle between the local meridian (True North) and Lambert or UTM North (Grid North – central meridian of the projection).

The values of declination related to the grid, and the value of convergence are normally indicated by a diagram on the right-hand margin of topographic maps.

REFERENCE COORDINATES (continued)

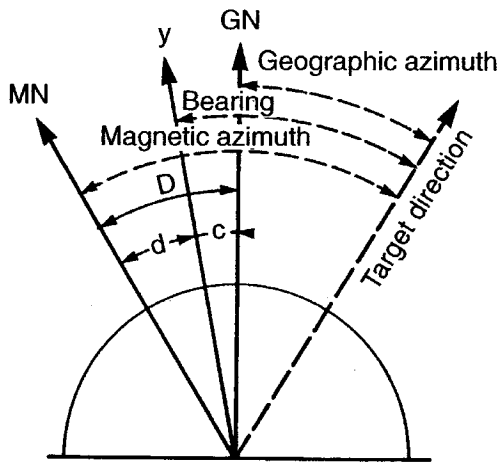

Magnetic declination corresponds to the center of the sheet and to 1 January 1967

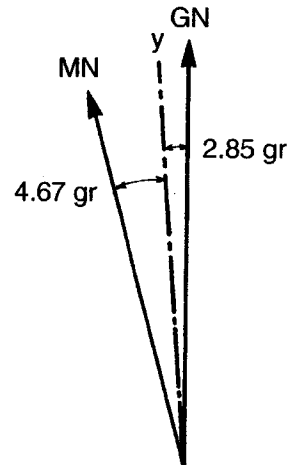

Magnetic declination decreases each year by 11 centesimal minutes

RELATIONSHIPS BETWEEN THE DIFFERENT ANGLES:

- y = North of kilometric grid
- D = Declination (varies according to location and time: ordinance maps provide details allowing their calculation)
- d = Declination related to grid
- c = Convergence angle of meridians (varies according to location)

According to the diagram of the specific case, the declination *d* related to the grid in 1968 is:

$$d = 4.67 - 0.11 \times 21 = 2.36 \text{ gr}$$

If the magnetic azimuth (MA) of the target measured by a compass is 150 gr:

$$\text{Lambert azimuth (LA) or bearing} = 150 - 2.36 = 147.64 \text{ gr}$$

$$\begin{aligned} \text{Geographic azimuth} &= \text{Lambert azimuth} - \text{convergence} \\ &= 147.64 - 2.85 = 144.79 \text{ gr} \end{aligned}$$

If the direction is marked using quadrants:

$$\text{MA} = 150 \text{ gr} = \text{S45E}$$

and according to the diagram:

$$\begin{aligned} \text{LA} &= \text{MA} + \text{convergence} \\ &= \text{S45E} + 2.85 \times 0.9 = \text{S47.56E} \end{aligned}$$

RADIUS OF CURVATURE AND PROJECTION IN THE VERTICAL PLANE

$AE = L$ Length drilled from A to E

$R = \frac{360 \Delta L}{2\pi \Delta i}$ Radius of curvature (m)

$gbu = \frac{\Delta i}{\Delta L}$ Rate of buildup (°/10 m)

in general $\frac{\Delta i}{\Delta L}$ is kept as constant as possible during kickoff (constant radius of curvature).

Hence:

$$R = \frac{573}{gbu}$$

$$D_E = R(1 - \cos i) \quad (\text{m})$$

$$\Delta Z = R \sin i \quad (\text{m})$$

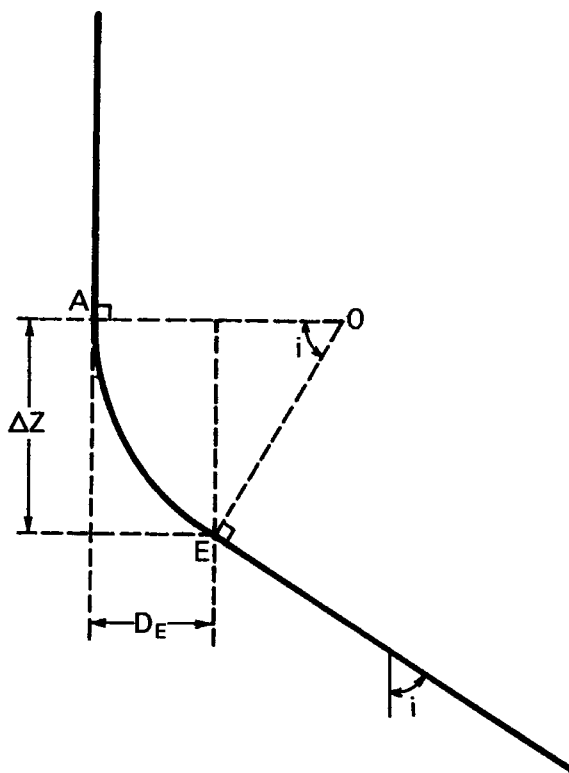

Radius of curvature for different rates of buildup:

gbu (°/10 m)	0.5	1.0	1.5	2.0	3.0	4.0	5.0	6.0	7.0	8.0	9.0	10.0
R (m)	1146	573	382	286	191	143	115	95	82	72	64	57

$\text{m} \times 3.28 = \text{ft}$ $^{\circ}/10 \text{ m} \times 3.048 = ^{\circ}/100 \text{ ft}$

**CALCULATION OF CHARACTERISTIC POINTS
OF THE THEORETICAL VERTICAL PROFILE**
J hole: $D > R$

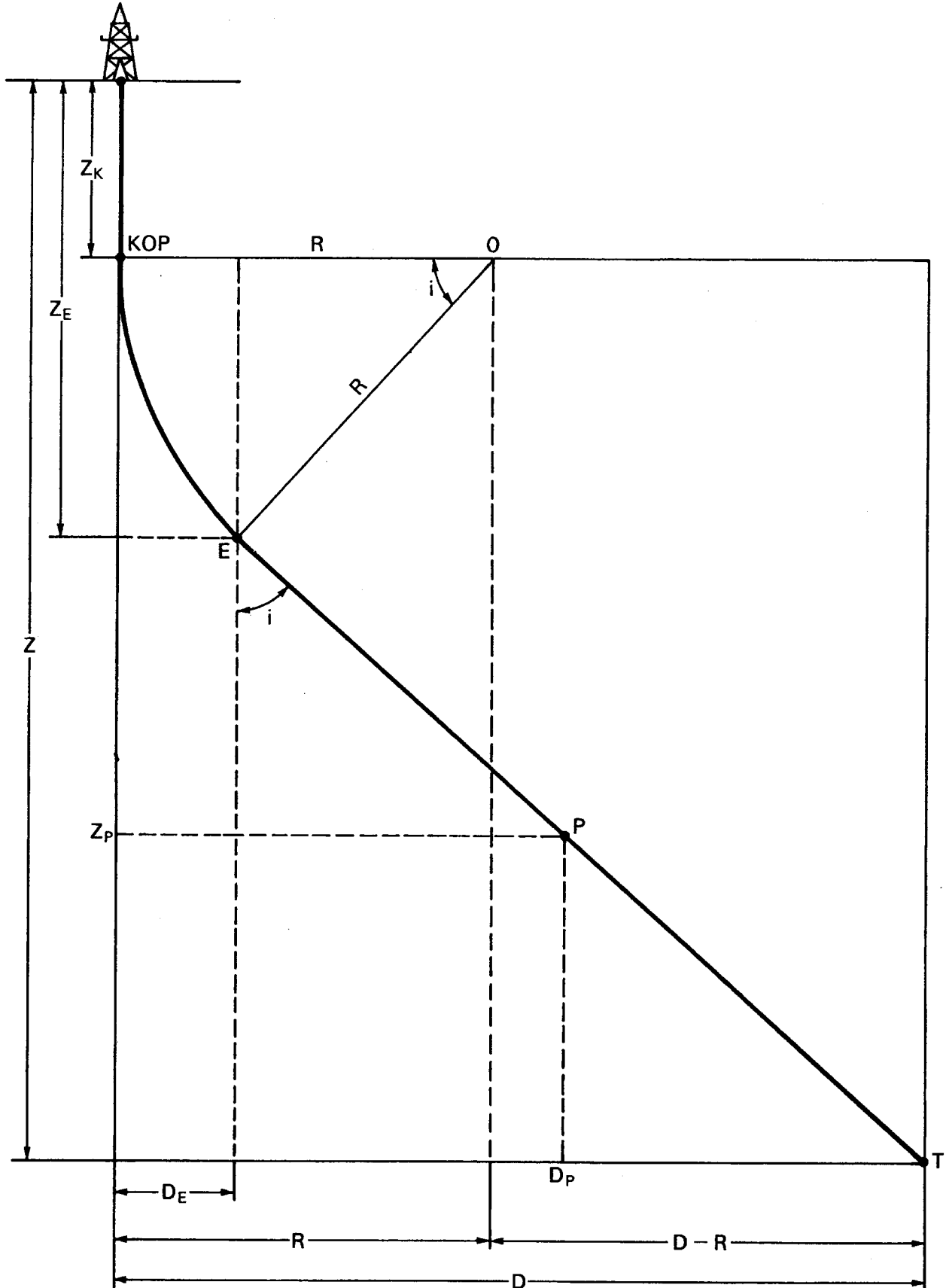

CALCULATION OF CHARACTERISTIC POINTS OF THE THEORETICAL VERTICAL PROFILE

J hole: $D > R$ (continued)

$$i = 180 - \tan^{-1} \left[\frac{Z - Z_K}{D - R} \right] - \cos^{-1} \left[\frac{R}{Z - Z_K} \sin \tan^{-1} \frac{Z - Z_K}{D - R} \right]$$

Example:

Displacement $D = 700$ m
 KOP $Z_K = 350$ m
 Vertical depth of target $Z = 2350$ m
 Rate of buildup $gbu = 1^\circ/10$ m ($R = 573$ m)

$$i = 180 - \tan^{-1} \left[\frac{2000}{700 - 573} \right] - \cos^{-1} \left[\frac{573}{2000} \sin \tan^{-1} \frac{2000}{700 - 573} \right]$$

$i = 20^\circ$

(see graphic method in J 13)

	Measured depth L (TMD)	Vertical depth Z (TVD)	Inclination	Displacement
Kickoff point (K)	Z_K	Z_K	0	0
End of deviation (E)	$L_E = Z_K + \frac{\pi i R}{180}$	$Z_E = Z_K + R \sin i$	i	$D_E = R(1 - \cos i)$
Target (T)	$L_T = Z_K + \frac{\pi i R}{180} + \frac{Z - Z_K - R \sin i}{\cos i}$	Z	i	D

Vertical depth Z_P as a function of drilled depth L_P at point P :

$$Z_P = Z_K + \frac{573}{gbu} \sin i + \left(L_P - Z_K - \frac{10i}{gbu} \right) \cos i$$

**CALCULATION OF CHARACTERISTIC POINTS
OF THE THEORETICAL VERTICAL PROFILE**

J hole: $D < R$

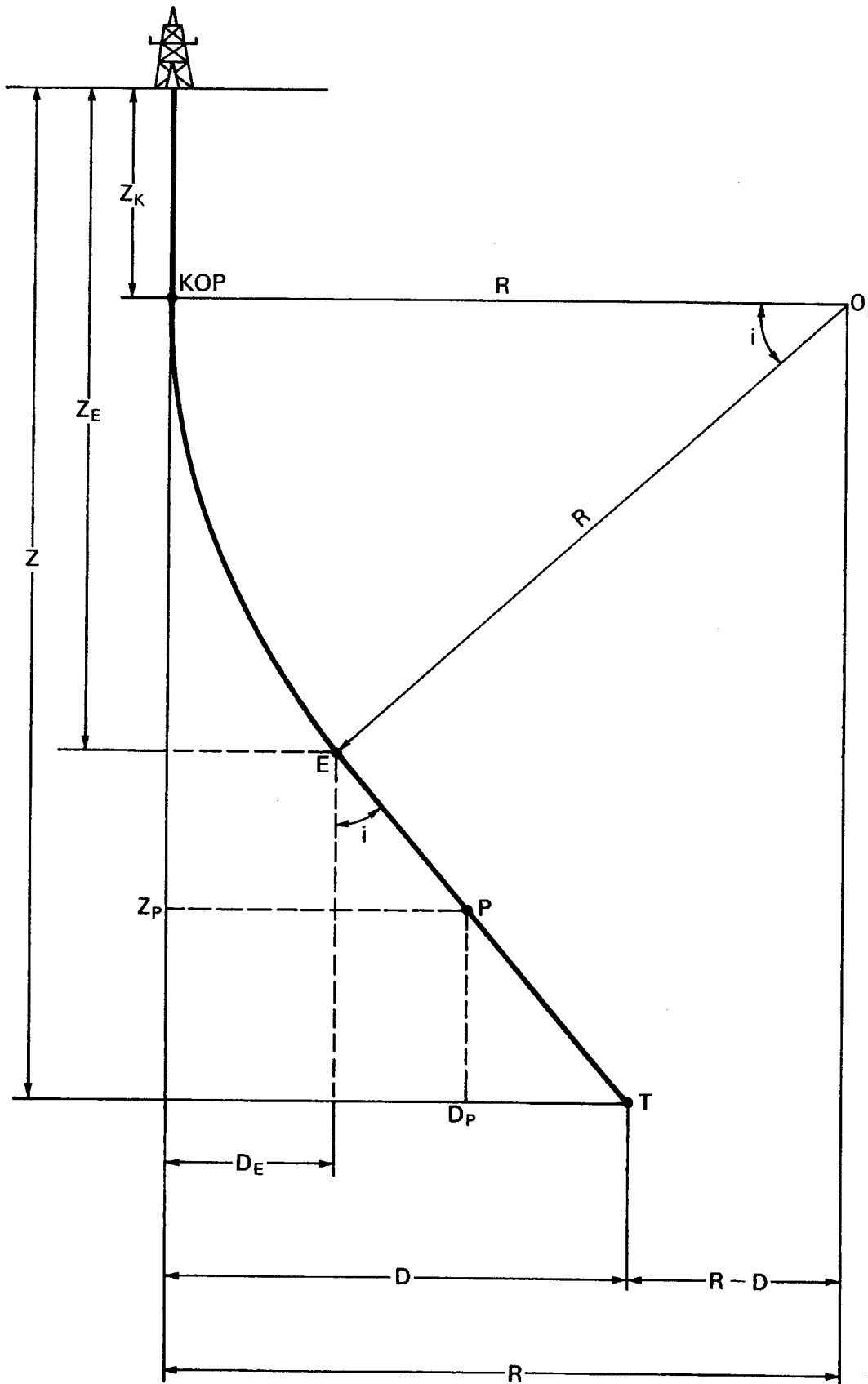

CALCULATION OF CHARACTERISTIC POINTS OF THE THEORETICAL VERTICAL PROFILE

J hole: $D < R$ (continued)

$$i = \tan^{-1} \left[\frac{Z - Z_K}{R - D} \right] - \cos^{-1} \left[\frac{R}{Z - Z_K} \sin \tan^{-1} \frac{Z - Z_K}{R - D} \right]$$

Example:

Displacement $D = 300$ m
 KOP $Z_K = 600$ m
 Vertical depth of target $Z = 1800$ m
 Rate of buildup $gbu = 1^\circ/10$ m ($R = 573$ m)

$$i = \tan^{-1} \left[\frac{1200}{573 - 300} \right] - \cos^{-1} \left[\frac{573}{1200} \sin \tan^{-1} \frac{1200}{573 - 300} \right]$$

$i = 15^\circ$

(see graphic method in J 13)

	Measured depth L (TMD)	Vertical depth Z (TVD)	Inclination	Displacement
Kickoff point (K)	Z_K	Z_K	0	0
End of deviation (E)	$L_E = Z_K + \frac{\pi i R}{180}$	$Z_E = Z_K + R \sin i$	i	$D_E = R(1 - \cos i)$
Target (T)	$L_T = Z_K + \frac{\pi i R}{180}$ $+ \frac{Z - Z_K - R \sin i}{\cos i}$	Z	i	D

Vertical depth Z_P as a function of drilled depth L_P at point P :

$$Z_P = Z_K + \frac{573}{gbu} \sin i + \left(L_P - Z_K - \frac{10i}{gbu} \right) \cos i$$

**CALCULATION OF CHARACTERISTIC POINTS
OF THE THEORETICAL VERTICAL PROFILE**

S hole: $R_1 + R_2 < D$

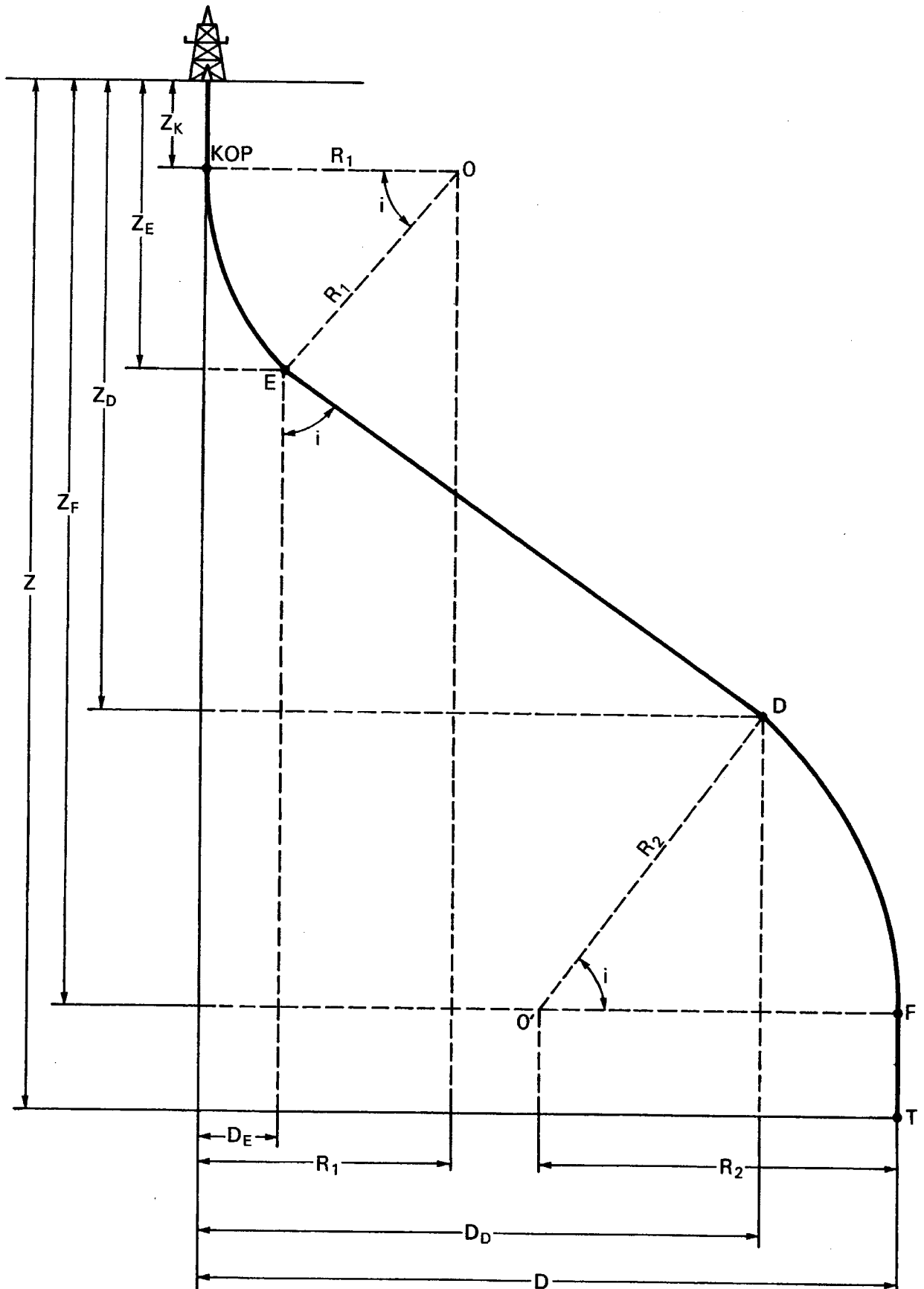

CALCULATION OF CHARACTERISTIC POINTS OF THE THEORETICAL VERTICAL PROFILE

S hole: $R_1 + R_2 < D$ (continued)

Assuming a return of the well to the vertical at F , the inclination i depends on the depth selected for point F :

$$i = 180 - \tan^{-1} \left[\frac{Z_F - Z_K}{D - R_1 - R_2} \right] - \cos^{-1} \left[\frac{R_1 + R_2}{Z_F - Z_K} \sin \tan^{-1} \frac{Z_F - Z_K}{D - R_1 - R_2} \right]$$

The remaining calculations are identical to those in J 5 and J 7 up to D (Z_D, D_D).

Vertical projection at D :

$$Z_D = Z_F - R_2 \sin i$$

Measured depth at D :

$$L_D = Z_K + \frac{\Pi i R_1}{180} + \frac{Z_D - Z_K - R_1 \sin i}{\cos i}$$

Displacement at D :

$$D_D = R_1 (1 - \cos i) + (Z_D - Z_K - R_1 \sin i) \tan i$$

Measured depth at F :

$$L_F = L_D + \frac{\Pi i R_2}{180}$$

Total measured depth at T :

$$L_T = Z_K + \frac{\Pi i R_1}{180} + \frac{Z_D - Z_K - R_1 \sin i}{\cos i} + \frac{\Pi i R_2}{180} + Z - Z_F$$

**CALCULATION OF CHARACTERISTIC POINTS
OF THE THEORETICAL VERTICAL PROFILE**

S hole: $R_1 + R_2 > D$

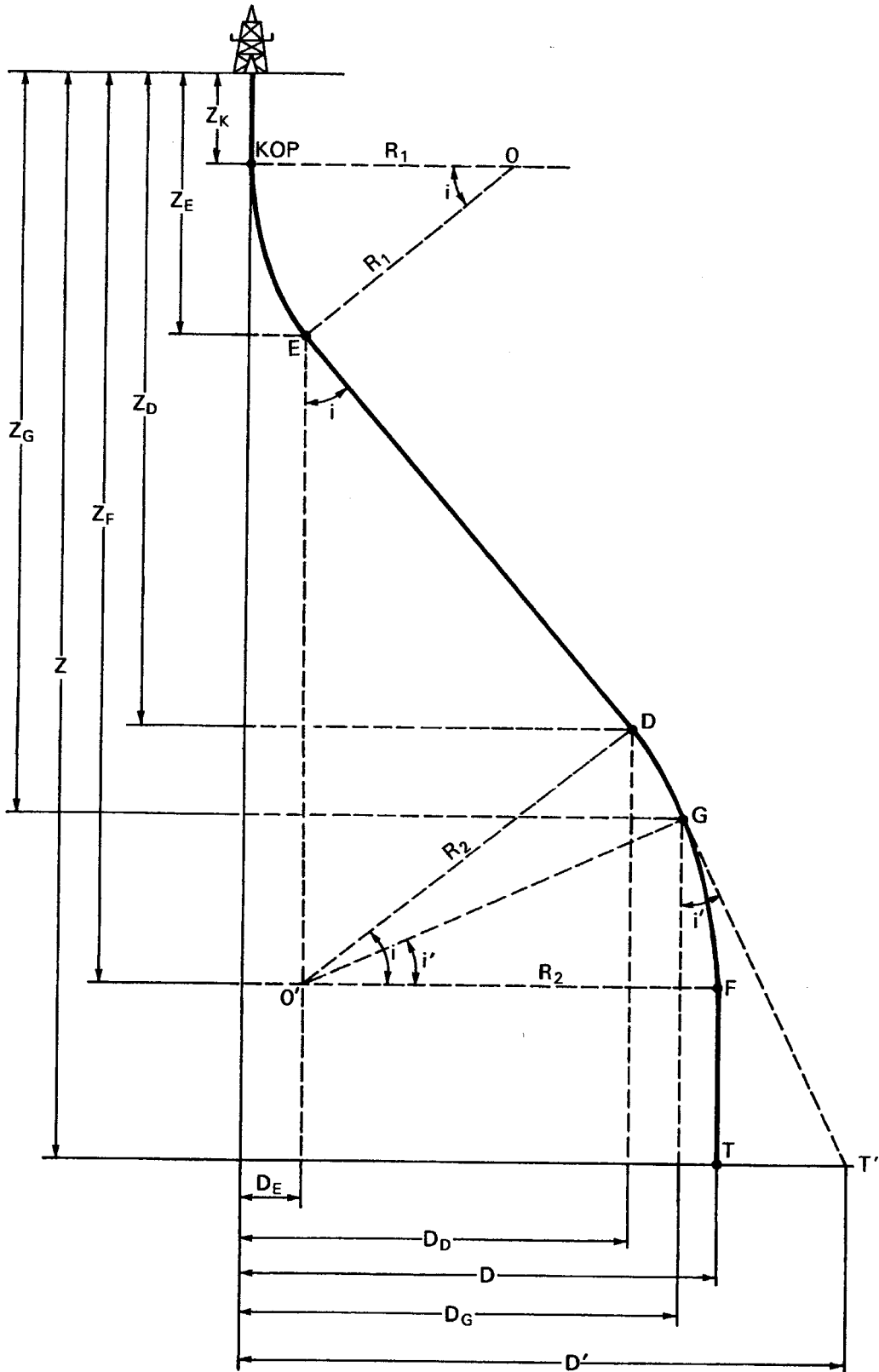

CALCULATION OF CHARACTERISTIC POINTS OF THE THEORETICAL VERTICAL PROFILE

S hole: $R_1 + R_2 > D$ (continued)

Assuming a return of the well to the vertical at F , the inclination i depends on the depth selected for point F :

$$i = \tan^{-1} \left[\frac{Z_F - Z_K}{R_1 + R_2 - D} \right] - \cos^{-1} \left[\frac{R_1 + R_2}{Z_F - Z_K} \sin \tan^{-1} \frac{Z_F - Z_K}{R_1 + R_2 - D} \right]$$

The remaining calculations are unchanged (see J 9).

If the well does not return to the vertical, the displacement at T' from point G becomes:

$$D' = D_G + (Z - Z_G) \tan i'$$

$$L_{T'} = L_G + \frac{(Z - Z_G)}{\cos i'}$$

THEORETICAL VERTICAL PROFILE RATE OF BUILDUP: 0.50 deg/10 m

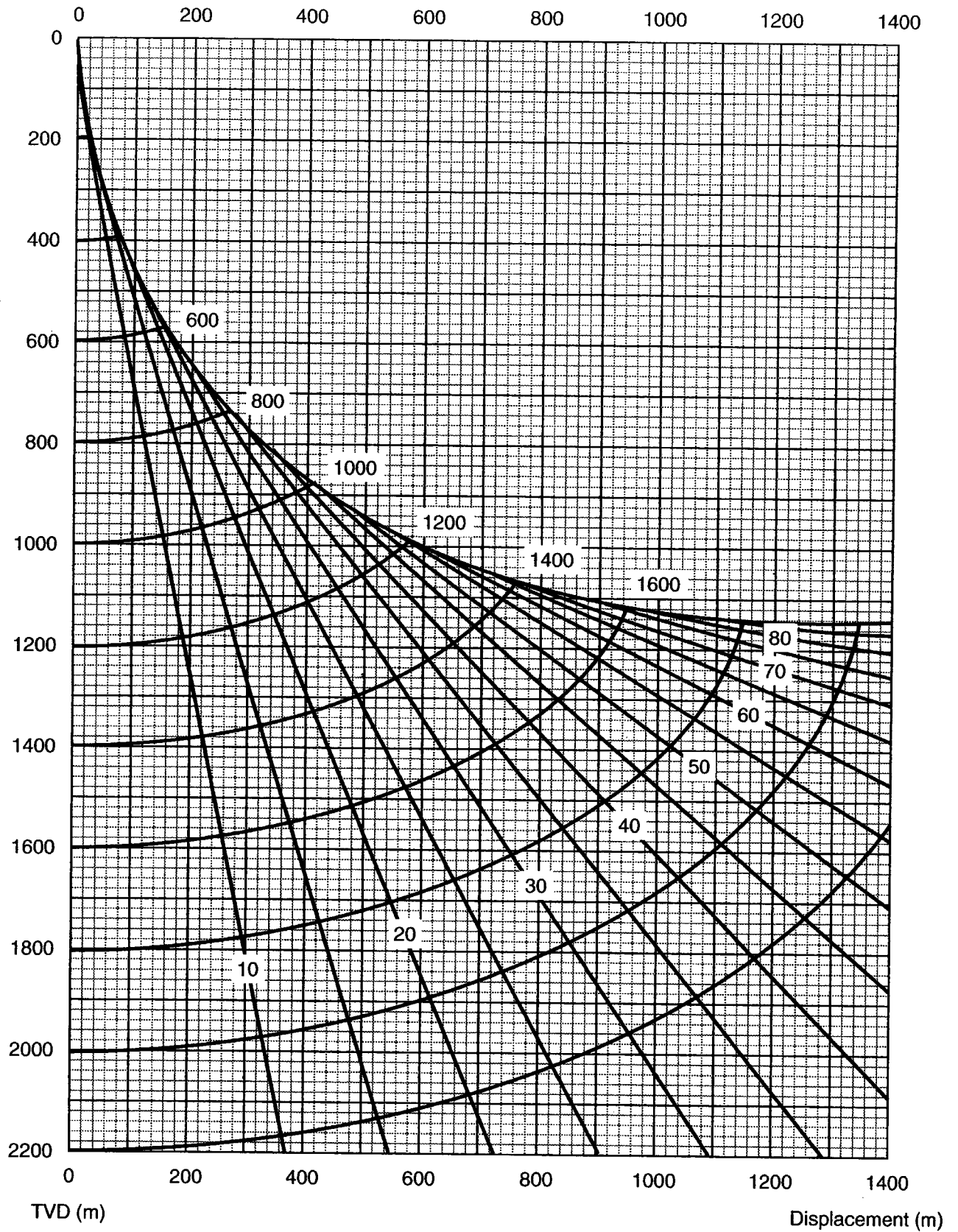

THEORETICAL VERTICAL PROFILE (continued) RATE OF BUILDUP: 1.00 deg/10 m

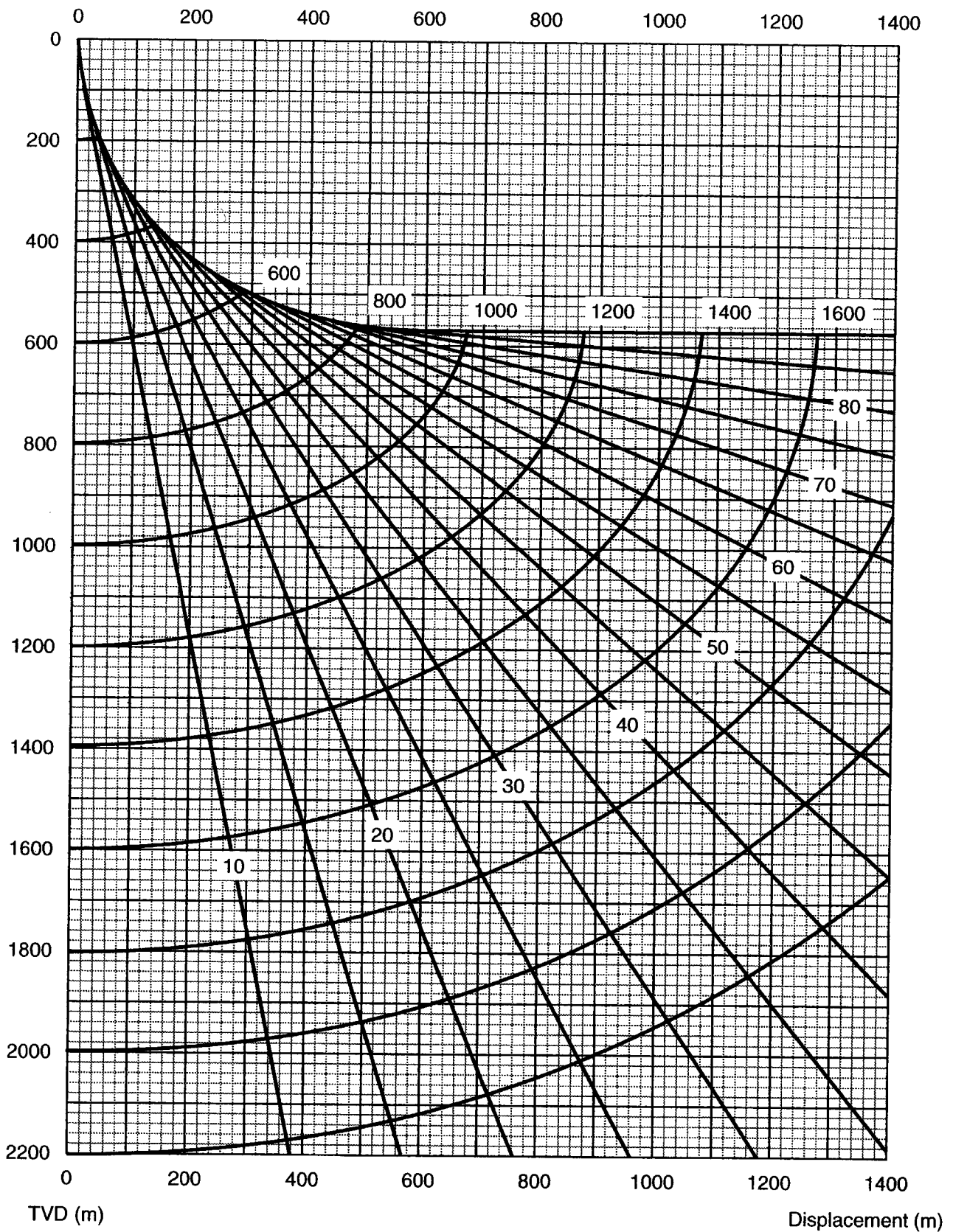

THEORETICAL VERTICAL PROFILE (continued)
RATE OF BUILDUP: 1.50 deg/10 m

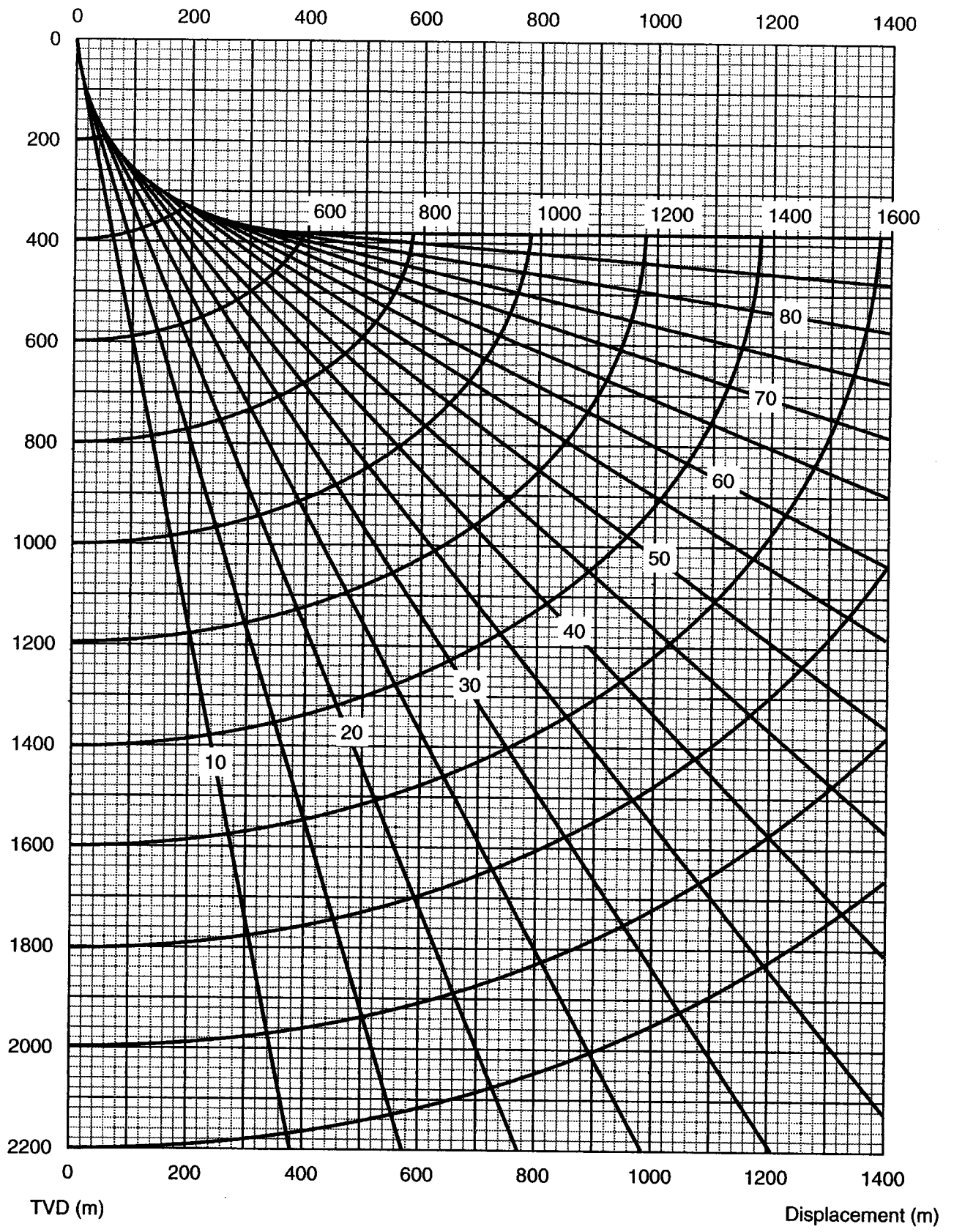

THEORETICAL VERTICAL PROFILE (continued) RATE OF BUILDUP: 2.00 deg/10 m

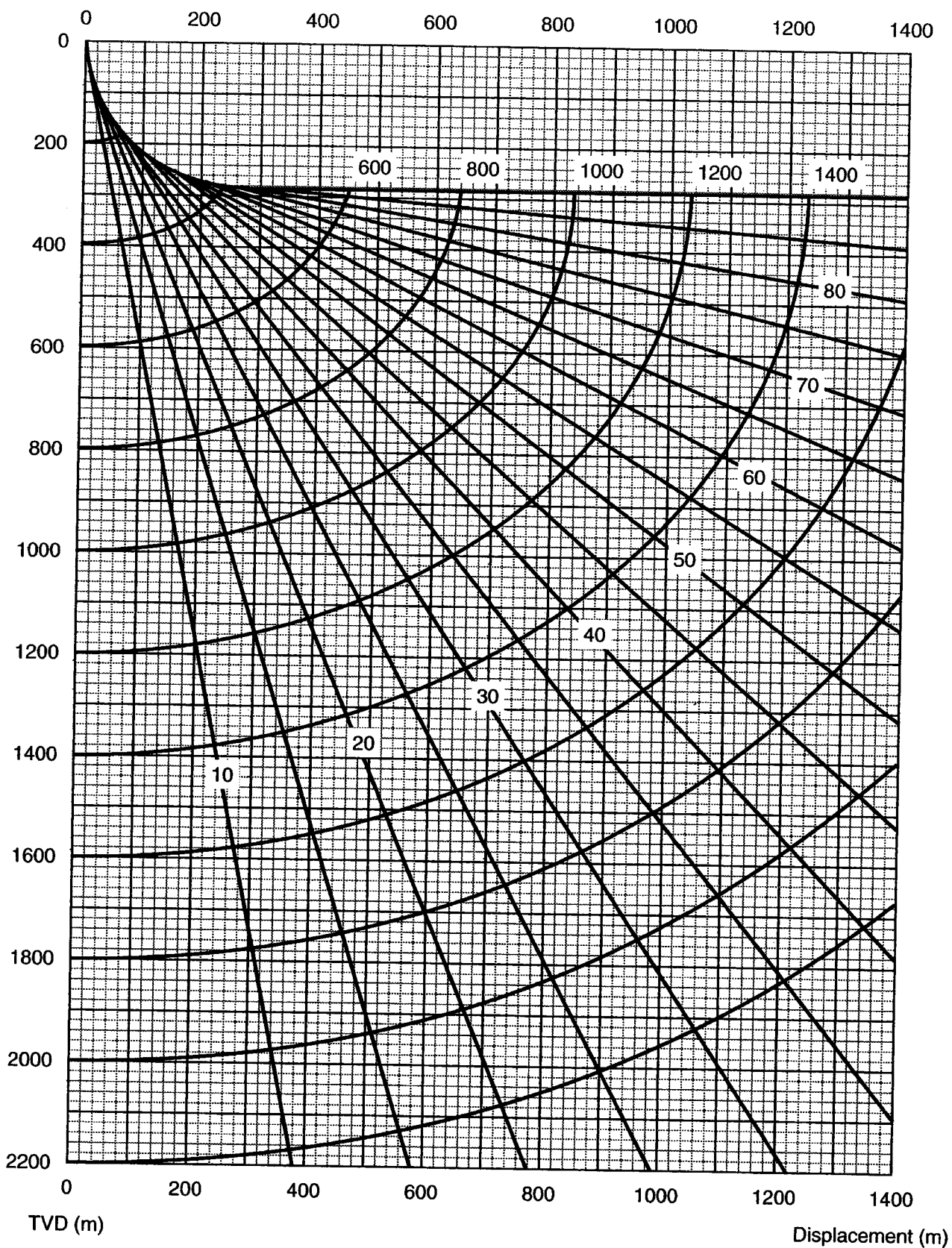

THEORETICAL VERTICAL PROFILE (continued)

RATE OF BUILDUP: 2.50 deg/10 m

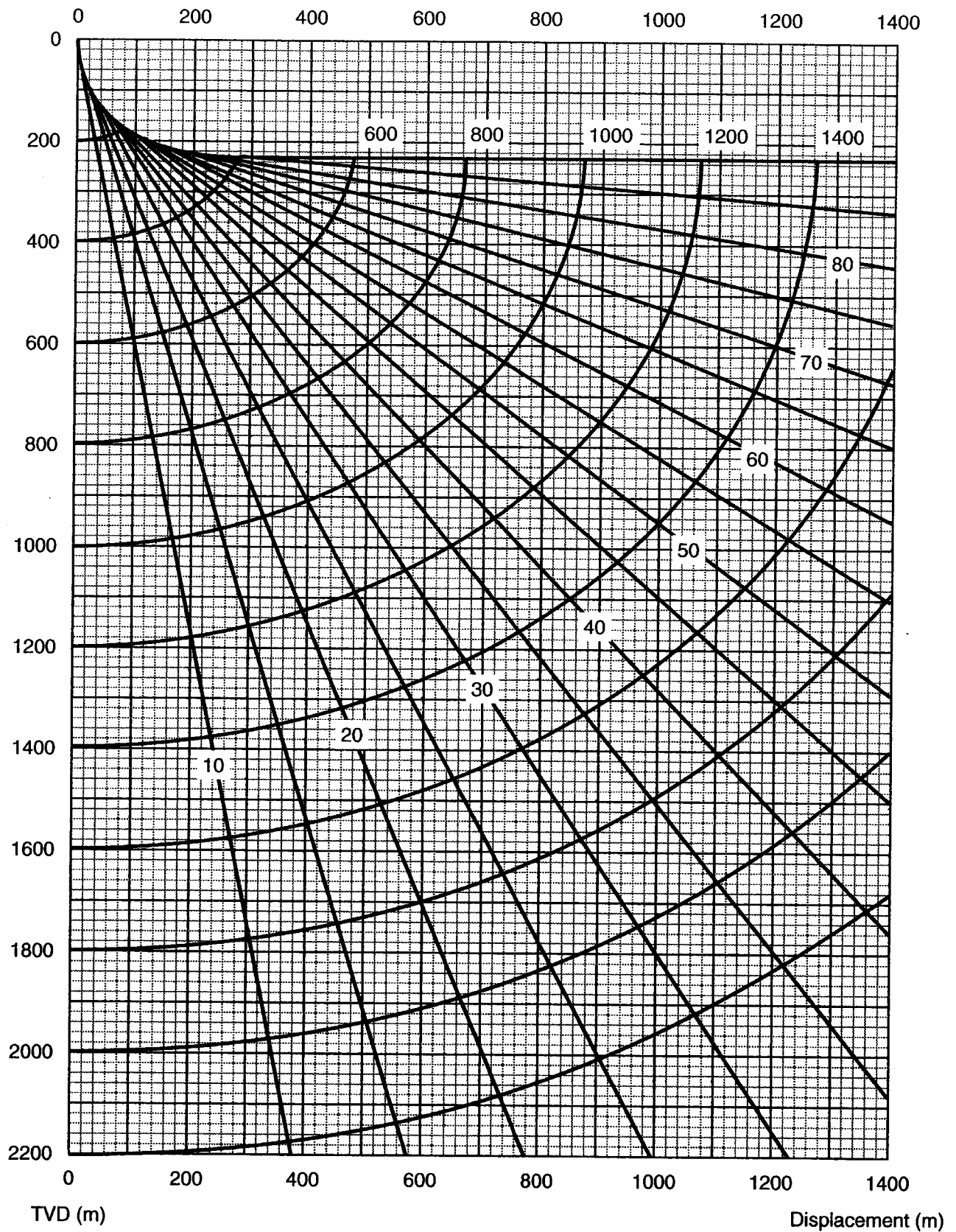

RAGLAND DIAGRAM

The Ragland diagram serves to determine the parameters used to calculate the orientation of the deflecting tool.

The diagram has four lines representing the characteristics of the hole and the deflecting tools.

These lines are the following:

- 1) Original direction and inclination of a part of the hole.

Example: 5° and N25E

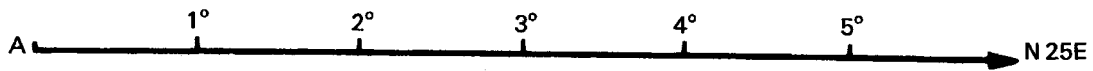

- 2) Dogleg circle (see dogleg formula in J 21).

Example: 1.5° dogleg

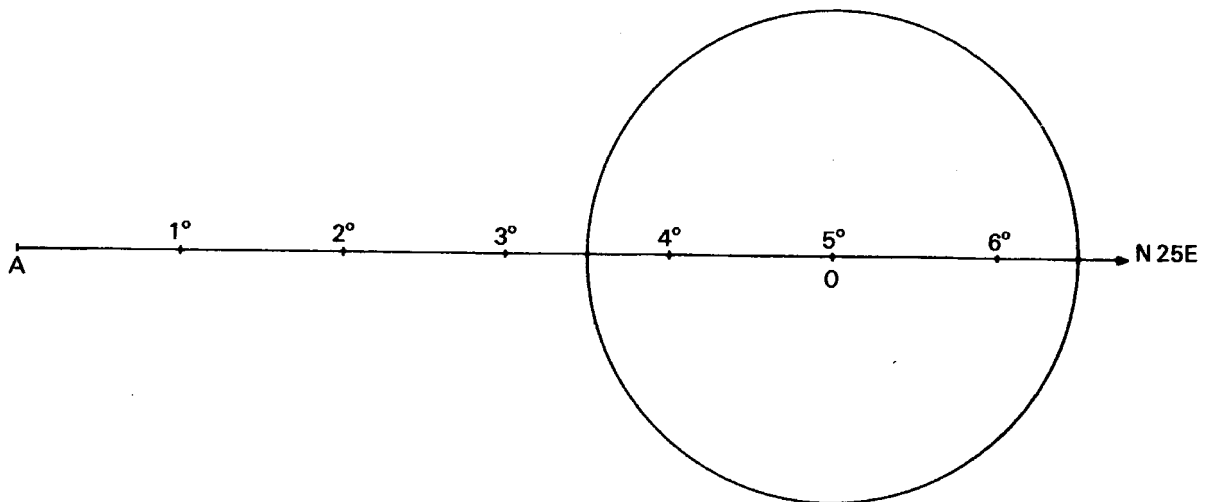

- 3) Orientation of deflecting tool in relation to the original direction, taking roll-off into account.

Example: deflecting tool 45° to the right of the original direction, i.e. N70E.

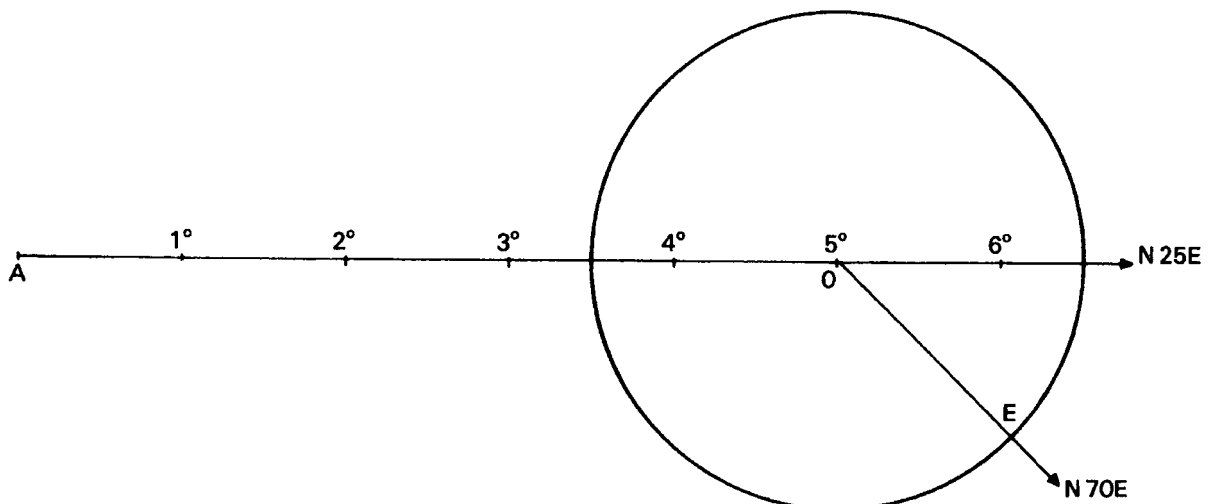

RAGLAND DIAGRAM (continued)

4) Direction obtained in relation to the original direction:

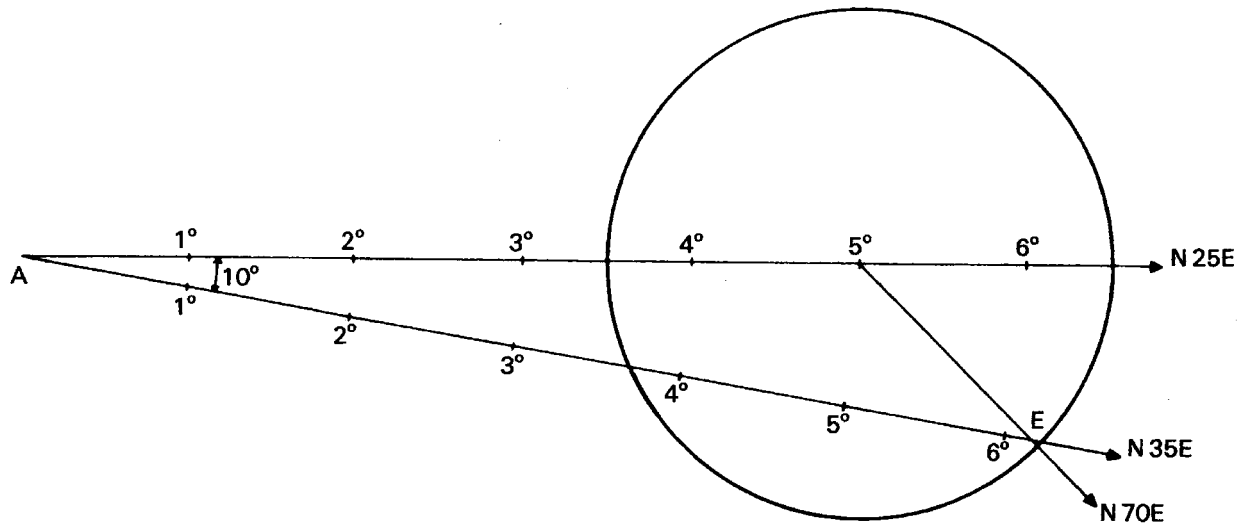

The angle between the two directions is 10 degrees.

The new direction is N35E.

Point *E* is common to the three lines:

- (a) Orientation of deflecting tool
- (b) Dogleg circle
- (c) Direction obtained.

The third point can be obtained if two of them are known.

CONTROL OF ACTUAL HOLE SHAPE Calculation of projections

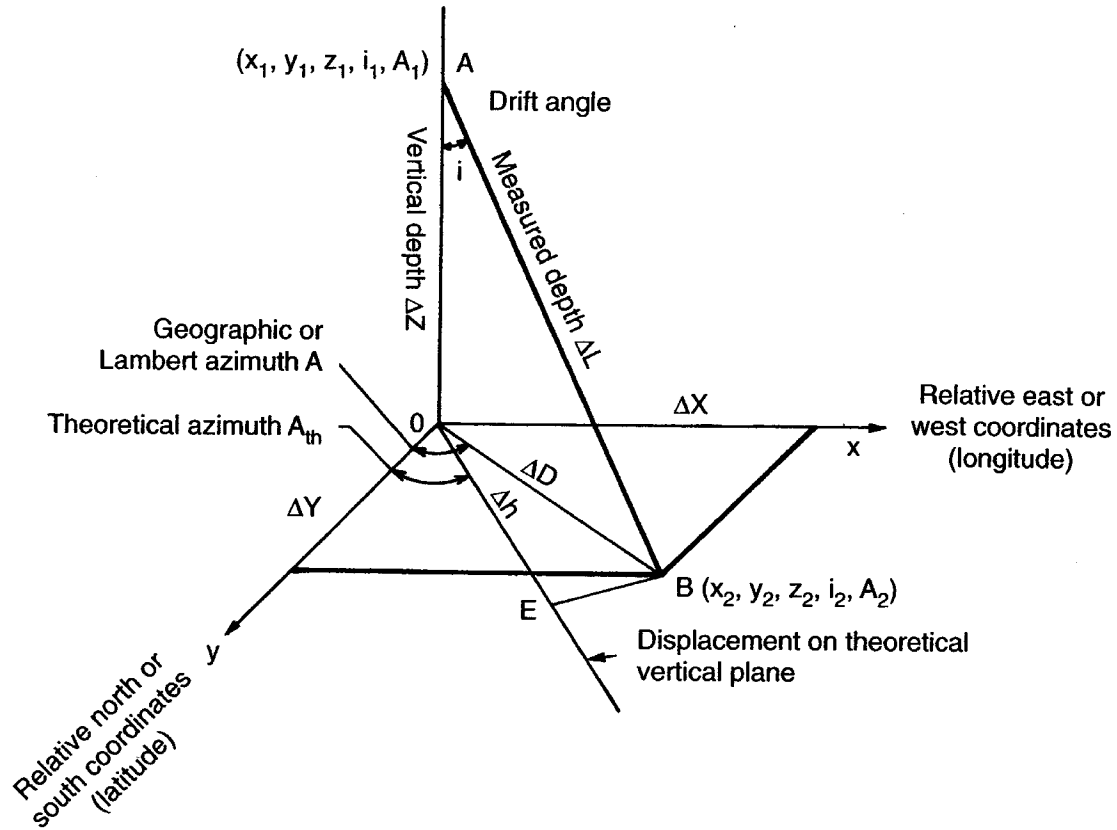

The following table gives the method to be used to calculate the different coordinates. Example of the method of the secant or average angle:

Element	Basic data		Calculation (average angle)
Vertical depth ΔZ	Course length between two consecutive surveys ΔL	Average drift angle $i = \frac{i_1 + i_2}{2}$	$\Delta Z = \Delta L \cos i$ $\Delta D = \Delta L \sin i$
Horizontal Displacement ΔD			
Relative north or south coordinates ΔY	Horizontal displacement ΔD	Average Lambert or geographic azimuth $A = \frac{A_1 + A_2}{2}$	$\Delta Y = \Delta D \cos A$ $\Delta X = \Delta D \sin A$
Relative east or west coordinates ΔX			
Projection on theoretical plane Δh		Angular difference between geographic azimuths of survey and target $(A - A_{th})$	$\Delta h = \Delta D \cos(A - A_{th})$

CONTROL OF ACTUAL HOLE SHAPE

Different calculation formulas

The drift angle i_1 and azimuth A_1 are measured at point A .

If i_2 and A_2 are measured at point B , lying at a distance ΔL from point A :

a. Tangent method

$$\Delta Z = \Delta L \cos i_2$$

$$\Delta D = \Delta L \sin i_2$$

$$\Delta Y = \Delta D \cos A_2$$

$$\Delta X = \Delta D \sin i_2$$

b. Secant or average angle method

$$\Delta Z = \Delta L \cos \frac{i_1 + i_2}{2}$$

$$\Delta D = \Delta L \sin \frac{i_1 + i_2}{2}$$

$$\Delta Y = \Delta D \cos \frac{A_1 + A_2}{2}$$

$$\Delta X = \Delta D \sin \frac{A_1 + A_2}{2}$$

c. Balanced tangent method

$$\Delta Z = \frac{\Delta L}{2} \cos i_1 + \frac{\Delta L}{2} \cos i_2$$

$$\Delta D = \frac{\Delta L}{2} \sin i_1 + \frac{\Delta L}{2} \sin i_2$$

$$\Delta Y = \frac{\Delta L}{2} \sin i_1 \cos A_1 + \frac{\Delta L}{2} \sin i_2 \cos A_2$$

$$\Delta X = \frac{\Delta L}{2} \sin i_1 \sin A_1 + \frac{\Delta L}{2} \sin i_2 \sin A_2$$

CONTROL OF ACTUAL HOLE SHAPE

Different calculation formulas (continued)

d. Radius of curvature method

$$\Delta Z = \frac{180}{\Pi} \frac{\Delta L}{i_2 - i_1} (\sin i_2 - \sin i_1)$$

$$\Delta D = \frac{180}{\Pi} \frac{\Delta L}{i_2 - i_1} (\cos i_1 - \cos i_2)$$

$$\Delta Y = \frac{180}{\Pi} \frac{\Delta D}{A_2 - A_1} (\sin A_2 - \sin A_1)$$

$$\Delta X = \frac{180}{\Pi} \frac{\Delta D}{A_2 - A_1} (\cos A_1 - \cos A_2)$$

e. Minimum curvature method

The drilled section is assimilated to a spherical arc with a minimum curvature (maximum radius):

if:

$$DLG = \cos^{-1}[\cos i_1 \cos i_2 + \sin i_1 \sin i_2 \cos(A_2 - A_1)]$$

and:

$$K = \frac{\Delta L}{DLG} \sin \frac{DLG}{2}$$

$$\Delta Z = K(\cos i_1 + \cos i_2)$$

$$\Delta D = K(\sin i_1 + \sin i_2)$$

$$\Delta Y = K(\sin i_1 \cos A_1 + \sin i_2 \cos A_2)$$

$$\Delta X = K(\sin i_1 \sin A_1 + \sin i_2 \sin A_2)$$

f. Dogleg

The formula for dogleg (DL) is the following:

$$DL = \cos^{-1}[\cos i_1 \cos i_2 + \sin i_1 \sin i_2 \cos(A_2 - A_1)]$$

g. Dogleg severity

The API formula for Dogleg severity is the following:

$$DLS = \frac{100}{\Delta L} (\cos)^{-1}[\cos i_1 \cos i_2 + \sin i_1 \sin i_2 \cos(A_2 - A_1)]$$

The values are expressed in degrees/100 ft if DL is in feet.

Other DLS formulas are available according to the calculation method employed.

COURSE CORRECTION

Let us assume that the last survey was made at point M :

$$M \begin{cases} \text{Drift angle} = i_M \\ \text{Azimuth} = A_M \\ \text{Coordinates} = X_M, Y_M, Z_M \end{cases}$$

The target is at point T :

$$T \text{ coordinates} = X_T, Y_T, Z_T$$

Drift angle correction

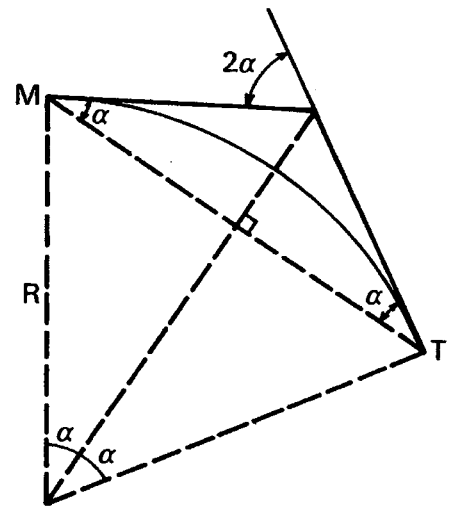
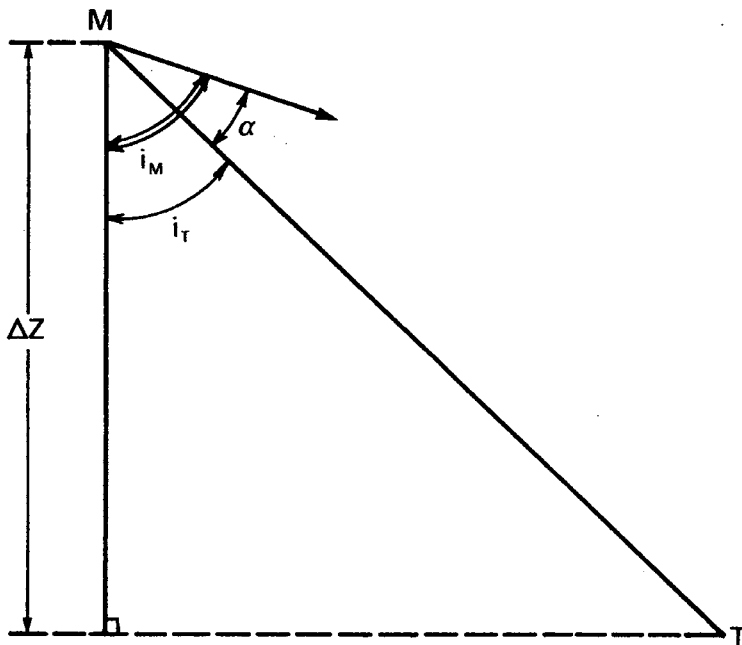

Change in drift angle : 2α

$$MT = \sqrt{(X_T - X_M)^2 + (Y_T - Y_M)^2 + (Z_T - Z_M)^2}$$

$$\Delta Z = Z_T - Z_M$$

$$i_T = \cos^{-1} \left[\frac{\Delta Z}{MT} \right]$$

$$\alpha = i_T - i_M$$

rate of build up:

$$\boxed{ROB = \frac{2\alpha}{MT}}$$

COURSE CORRECTION (continued)

Azimuth correction

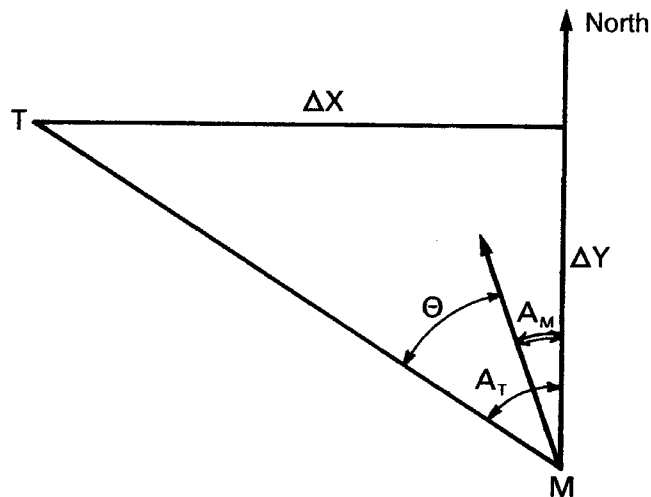

$$\Delta X = X_T - X_M$$

$$\Delta Y = Y_T - Y_M$$

$$A_T = \tan^{-1} \left[\frac{\Delta X}{\Delta Y} \right]$$

$$\theta = A_T - A_M$$

rate of azimuth change:

$$ROW = \frac{2\theta}{MT}$$

Possible azimuth variation with a deflecting tool

The maximum angle that can be turned to right or left with a deflecting tool is given by the practical formula:

$$\Delta A = \frac{180}{i}$$

where ΔA is the maximum azimuth variation with a hole inclination i .

RADIUS OF BOREHOLE CURVATURE LIMITATION ON DOWNHOLE TOOLS

The length of a rigid downhole tool that can be run in a deviated well is given by:

$$L = 2\sqrt{(R + 0.0254 D_H)^2 - (R + 0.0254 D_t)^2}$$

where:

- L = Maximum length of the downhole tool in meters
- R = Radius of borehole curvature in meters (see page J 3)
- D_H = Borehole diameter in inches
- D_t = Tool diameter in inches

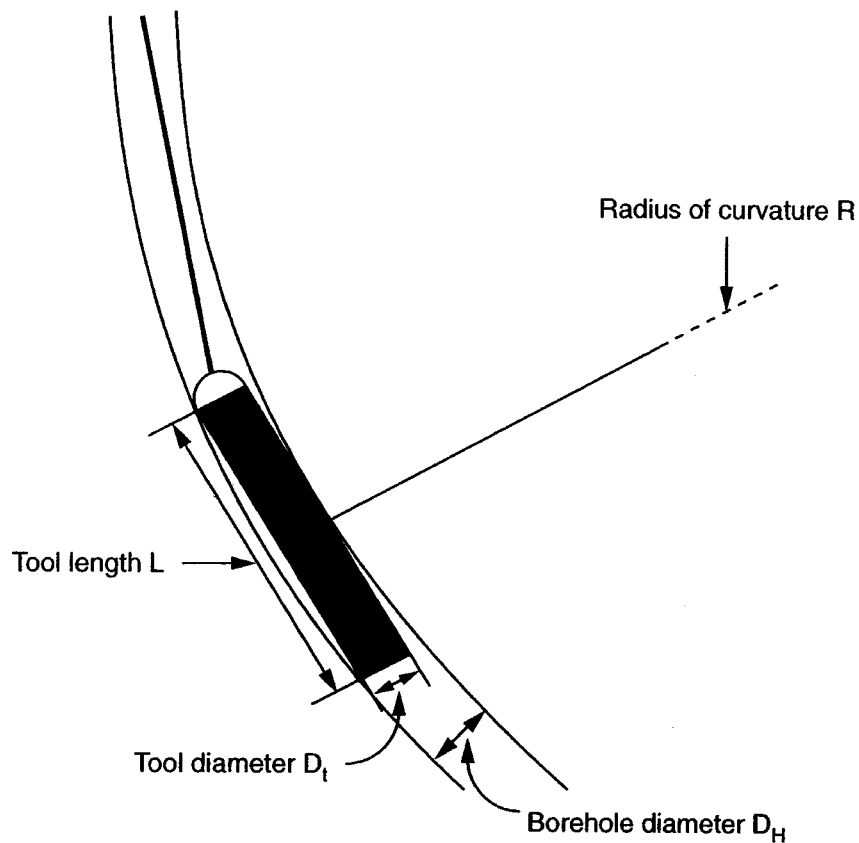

Conversely, the minimum radius of curvature of a well in which a specific rigid tool can be run is given by:

$$R = \frac{L^2 - 0.00258(D_H^2 - D_t^2)}{0.2032(D_H - D_t)}$$

RADIUS OF BOREHOLE CURVATURE LIMITATION ON DOWNHOLE TOOLS (continued)

Example 1:

Borehole diameter: 5 3/4 in
 Radius of curvature: 143 m (4°/10 m)
 Tool diameter: 3 1/2 in

$$L = 2\sqrt{(143 + 0.0254 \times 5.75)^2 - (143 + 0.0254 \times 3.5)^2} = 8.09 \text{ m}$$

Example 2:

Borehole diameter: 6 in
 Tool length: 6.40 m (21 ft)
 Tool diameter: 2 3/4 in

$$R = \frac{6.40^2 - 0.00258(6^2 - 2.75^2)}{0.2032(6 - 2.75)} = 61.91 \text{ m}$$

The equivalent *gbu* is: $gbu = \frac{573}{61.91} = 9.25^\circ/10 \text{ m}$

K

kick control fishing

Main symbols used.....	K1-K2
Preliminary calculations.....	K3
Driller's procedures.....	K4-K5
Calculation after well shut-in.....	K6
Driller's method on land or on fixed support.....	K7
Wait and weight method on land or on fixed support.....	K8
Wait and weight method on floating support (Example without kick assembly).....	K9
Control on a floating rig.....	K10
Well strength.....	K11-K12
Charts giving coefficient K and gas specific gravity.....	K13
Example of kick control.....	K14-K17
Determination of the length of free pipe in a stuck string.....	K18-K19
Maximum allowable number of turns which can be given to 1000 m of new drill pipe under a given axial tension (Grade E drill pipe).....	K20
Maximum allowable number of turns which can be given to 1000 m of new drill pipe under a given axial tension (Grade X95 drill pipe).....	K21

Maximum allowable number of turns which can be given to 1000 m of new drill pipe under a given axial tension (Grade G105 drill pipe).....	K22
Maximum allowable number of turns which can be given to 1000 m of new drill pipe under a given axial tension (Grade S135 drill pipe).....	K23
Back-off.....	K24
Tool joint matting surface area (API Spec 7, April 1, 1994).....	K25

MAIN SYMBOLS USED

B	barite weight to be added to $V\text{m}^3$ of mud to raise the mud weight from d_1 to d_2 (kg)
B_r	rate of barite addition (kg/min)
BHP	Bottom Hole Pressure (kPa)
C_i	number of pump strokes corresponding to drill string internal volume V_i
C_a	number of pump strokes corresponding to total annular volume V_a
C_{oh}	number of pump strokes corresponding to open-hole annular volume V_{oh}
CP	Circulating Pressure (kPa)
d_1	initial specific gravity of the mud (at shut-in)
d_2	intermediate specific gravity in case of multi-step weighting
d_e	specific gravity of the mud balancing formation pressure
d_{frac}	specific gravity of the mud corresponding to formation fracture
d_g	specific gravity (or density in kg/l) of gas measured with respect to water
d_r	specific gravity of the mud required to kill the well
FCP	Final Circulating Pressure at kill rate with mud at specific gravity d_r (kPa)
G	volume of kick measured at shut-in (liter)
G_{max}	maximum volume of kick to avoid fracture at shoe or exceeding the maximum working pressure (liter)
h	height of gas influx (m)
HP	Hydrostatic Pressure (kPa)
ICP	Initial Circulating Pressure at kill rate with mud at specific gravity d_1 (kPa)
ICP ₂	Initial Circulating Pressure at kill rate with mud at specific gravity d_2 (kPa)
K	ratio $\frac{T_s Z_s}{Z_b T_b}$ of $ZT\left(\frac{PV}{ZT} = \text{constant}\right)$ between surface and bottom hole
MAASP	Maximum Allowable Annulus Surface Pressure, well shut-in, corresponding to fracturing at weak zone (or shoe) (kPa)
N	pump speed (strokes) corresponding to drilling flow rate (strokes/min)
N_r	pump speed (strokes) corresponding to kill flow rate (strokes/min)
P_a	annulus surface pressure during kick control (kPa)
P_{afg}	static surface annulus pressure, well full of gas (kPa)
$P_{a\ max}$	annulus surface pressure when gas reaches surface (kPa)
P_{dp}	drill pipe pressure (kPa)
ΔP_{cl}	pressure losses in choke line (kPa)
P_f	formation pressure (kPa)
P_{frac}	fracturing pressure at weak zone (kPa)
ΔP_{ka}	additional pressure loss due to circulating head (kick assembly) and to pumping line between reading pressure gauge and circulating head on floating rig (kPa)
P_{max}	maximum safe casing pressure, either the working pressure of the BOP's or the bursting strength of the last casing string, whichever is the lowest. This pressure must never be exceeded (kPa)
P_s	pressure at weak zone (or shoe) (kPa)
$P_{s\ max}$	maximum pressure at weak zone (or shoe) (kPa)
P_{sr_1}	pressure losses at kill (slow) rate with mud specific gravity d_1 , measured by the normal drilling circuit (shale shakers or riser) (kPa)

MAIN SYMBOLS USED (continued)

P_{sr_2}	pressure losses at kill (slow) rate with mud specific gravity d_2 , measured by the normal drilling circuit (shale shakers or riser) (kPa)
P_{sr_1}	pressure losses at kill (slow) rate with mud specific gravity d_1 , measured by the normal drilling circuit (shale shakers or riser) (kPa)
Q	flow rate during drilling operation (l/min)
Q_r	flow rate (reduced) during kill operation (l/min)
S	downhole pressure increase (safety margin) during kill operation (kPa)
SICP	stabilized annulus (casing) pressure, well shut-in, after kick (kPa)
SIDPP	stabilized drill pipe pressure, well shut-in, after kick, with mud at specific gravity d_1 (kPa)
SIDPP ₂	stabilized drill pipe pressure, well shut-in, after kick, with mud at specific gravity d_2 (kPa)
V	total volume of mud to be weighted (including tanks) (m ³)
V_a	total annulus volume (m ³)
v_a	volume per meter of annulus (l/m)
v_{ab}	volume per meter of annulus downhole (l/m)
V_B	volume increase due to barite weighting of V m ³ of mud from d_1 to d_2 (m ³)
V_i	drill string internal volume (m ³)
V_{oh}	open-hole annular volume (m ³)
V_{tk}	volume of mud in tanks (m ³)
Z	vertical depth (m)
Z_s	vertical depth at weak zone (or shoe) (m)

PRELIMINARY CALCULATIONS

To act promptly and effectively when a kick occurs, certain data, necessary to control a well, must be known or determined in advance, and the values regularly updated.

VOLUMES OF CIRCULATING FLUIDS

V_i = inside volume of drill string (m^3)

V_a = total annular volume (m^3)

V_{oh} = open-hole annular volume (m^3)

V_{tk} = volume of mud in tanks (m^3)

REDUCED MUD FLOW RATE TO CONTROL A KICK

The reduced mud flow rate Q_r selected in advance, generally ranges between a half and a quarter of the drilling mud flow rate Q (usually $Q/2$). It is selected according to the geometry of the well, and the surface installation.

NUMBER OF CIRCULATING STROKES AT REDUCED MUD FLOW RATE

a) From surface to bit:

$$C_i = \frac{V_i}{Q_r} N_r$$

b) From bit to surface:

$$C_a = \frac{V_a}{Q_r} N_r$$

c) Corresponding to open-hole annular volume:

$$C_{oh} = \frac{V_{oh}}{Q_r} N_r$$

PRESSURE LOSSES AT REDUCED MUD FLOW RATE WITH INITIAL MUD WEIGHT (P_{sr_1})

These pressure losses can be determined as drilling proceeds:

- (a) At fixed times, at crew changes for example
- (b) After running a new bit before resuming drilling.

These pressure losses are measured onshore and offshore by the normal drilling circuit.

Additional pressure losses ΔP_{cl} occur when circulating in the control lines. They are normally negligible on land or on a fixed offshore support, but are higher on a floating rig.

Since these additional pressure losses occur in the annulus, they must not appear in the expression of the circulating pressure during control.

MAASP and d_{frac}

(see Well strength, K 11).

COMPANY

DRILLER'S PROCEDURES for well control

(DRILLING FROM LAND OR FIXED SUPPORT)

WELL :	Phase :	Depth of well zone :	Mud weight	Max. Pres. P_{max}	Updated on :
	Shoe depth :	Leak-off test equiv-mud weight :	MAASP		Supervisor :

1. At every bit change or crew change :

Circulate off bottom for 5 minutes at reduced flow rate and record pressure loss (P_{sr1}).

Reduced flow rate	Pump No. { 1 2 }	Liner size	Volume per stroke	Strokes per minute	P_{sr1} { ----- }
-------------------	---------------------	------------	-------------------	--------------------	---------------------

2. If any of the following occurs during drilling, coring, or circulating :

- Increase in drilling rate.
- Increase of flow across shale shaker.
- Increase in pit level.
- Gas cut mud.
- Increase in mud chloride content.
- Partial or total mud losses (1).

- Pick up kelly until T.J. is 3 ft above rotary table.
- Shut off mud pump - check for well flow or losses.
- Notify operator and contractor Tool pusher.

IF WELL IS STABLE

- Resume circulation.
- Check for mud pit level, mud weight, and shows.
- Resume operations.

IF WELL IS FLOWING

- Open the choke line, the choke being fully open.
- Close the annular BOP.
- Slowly close the choke and record casing and drill pipe pressure for 15 minutes.

IF WELL IS LOOSING

- Circulate at reduced flow rate.
- Check for losses.
- Wait for orders.

IF CASING PRESSURE REACHES MAASP

follow the instructions here under :

IF CASING PRESSURE IS LESS THAN MAASP

Record this pressure $SICP =$

Calculate ICP as follows :

- note the stabilized drill pipe pressure
- add the pressure loss at reduced flow rate
- add the trip margin

$SIDPP =$

$S_{sr1} =$

$S =$

$ICP =$

TOTAL (2)

— Open adjustable choke and simultaneously start pump at reduced flow rate, adjust choke to maintain a constant pressure equal to ICP. Do not take care of casing pressure as far as this pressure is less than P_{max} .

The casing pressure must never be higher than P_{max}

- Stop tripping.
- Check for well flow or losses.
- Notify operator and contractor Tool pusher.

IF THE WELL IS STABLE

Unless otherwise notified:

- Run pipe back to bottom. In case of losses keep annulus full if possible.
- Resume circulating at reduced flow rate, eventually under control at constant DP pressure (Caution: some gas may enter the well bore).

IF THE WELL IS FLOWING

- Make up an inside back pressure valve in drill string.
- With minimum delay, run pipe back to bottom. Check mud gain.
- On bottom proceed as above § 2.

**IF THE FLOW IS INCREASING. OR
IF THE MUD GAIN REACHES OR
IF GAS FLOWS**

- Stop tripping.
- Close the annular BOP
- Slowly close the choke.
- Wait for orders.
- Bleed off if casing pressure reaches P_{max} .

CALCULATION AFTER WELL SHUT-IN

Basic calculations

$$P_f = \text{SIDDP} + 9.81 Z d_1$$

$$d_e = \frac{P_f}{9.81 Z}$$

$$\text{ICP} = \text{SIDDP} + P_{sr_1} + S$$

$$d_r = d_1 + \frac{\text{SIDDP} + S}{9.81 Z}$$

$$\text{FCP} = P_{sr_r} = P_{sr_1} \frac{d_r}{d_1}$$

Circulation of an intermediate mud weight d_2

From the time when mud d_2 reaches the bit, the casing pressure becomes:

$$\text{ICP}_2 = \text{SIDDP}_2 + P_{sr_2} + S$$

with:

$$\text{SIDPP}_2 = P_f - 9.81 Z d_2$$

$$P_{sr_2} = P_{sr_1} \frac{d_2}{d_1}$$

Special case, if:

$$d_2 = \frac{d_1 + d_r}{2}$$

then:

$$\text{ICP}_2 = \frac{\text{ICP} + \text{FCP}}{2}$$

Barite addition

Barite weight to be added to $V \text{ m}^3$ of mud to raise the specific gravity from d_1 to d_2 :

$$B = 4.2 V \frac{d_2 - d_1}{4.2 - d_2} \quad (\text{in metric tons})$$

rate of barite addition at flow rate Q_r to raise the specific gravity from d_1 to d_2 :

$$B = 4.2 Q_r \frac{d_2 - d_1}{4.2 - d_2} \quad (\text{in kg/min})$$

Volume increase due to barite addition:

$$V_B = \frac{B}{4.2} \quad (\text{in m}^3)$$

DRILLER'S METHOD ON LAND OR ON FIXED SUPPORT

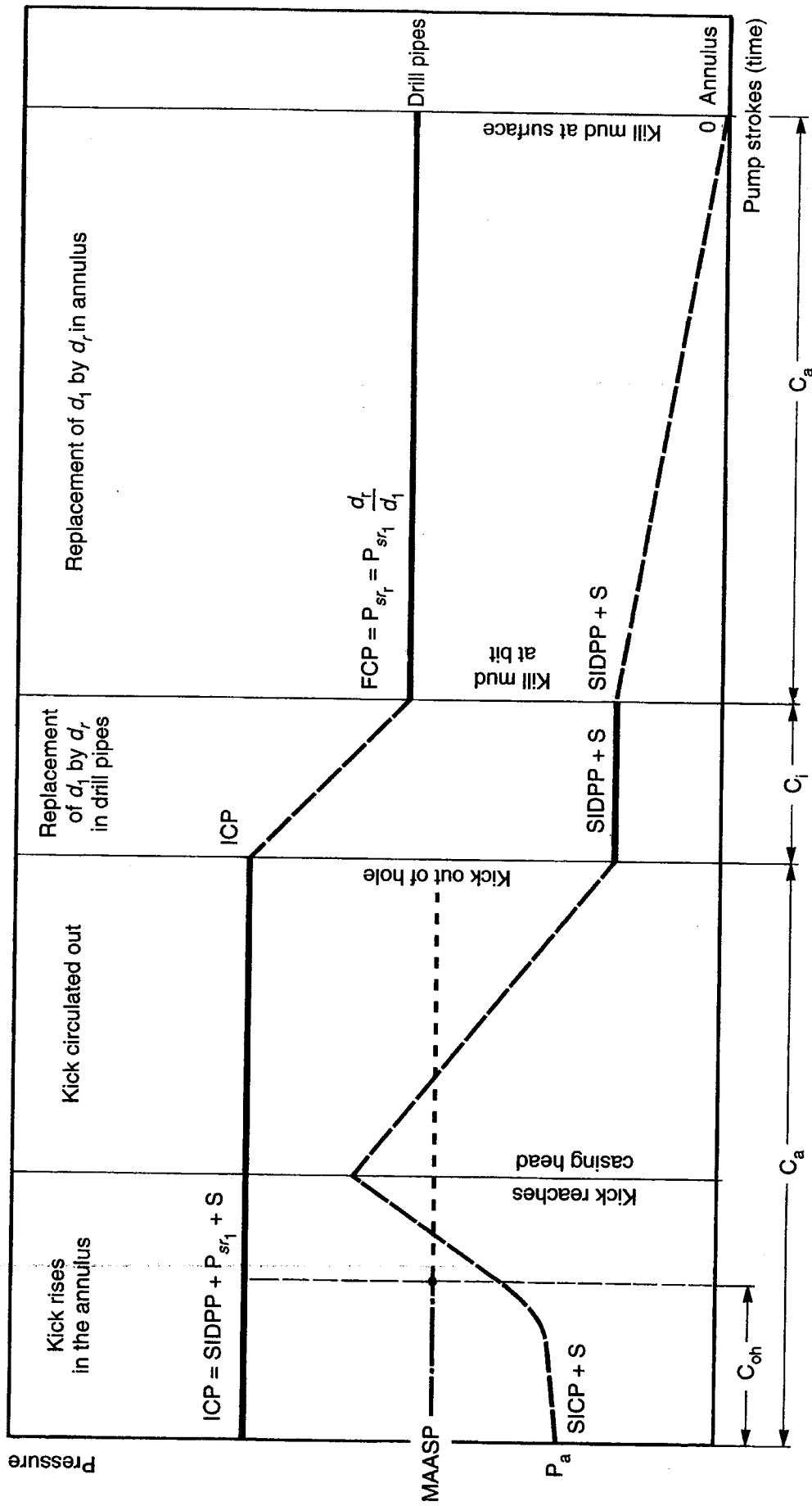

Choke must be adjusted to follow the solid line

WAIT AND WEIGHT METHOD ON LAND OR ON FIXED SUPPORT

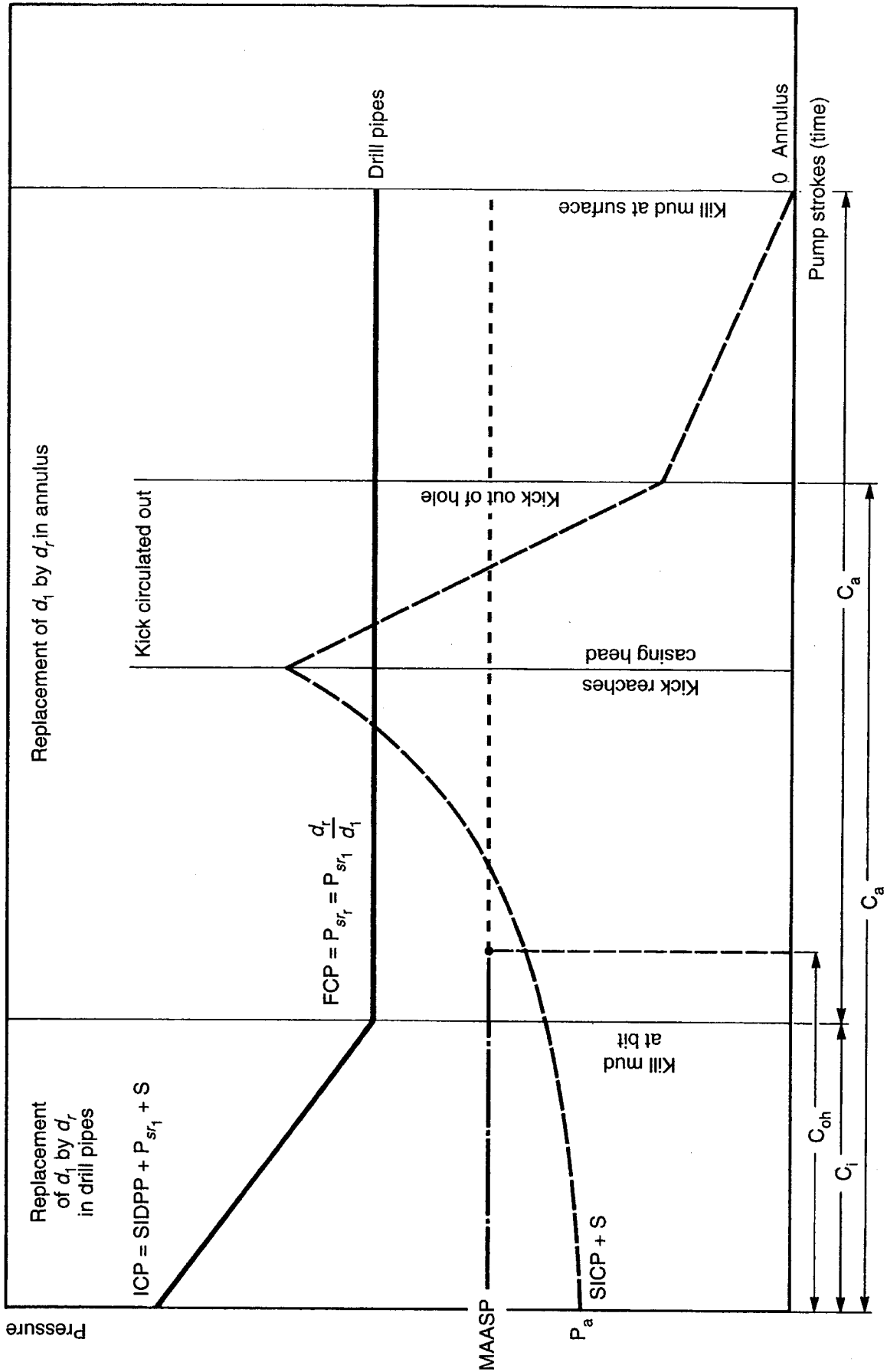

Choke must be adjusted to follow the solid line

WAIT AND WEIGHT METHOD ON FLOATING SUPPORT (Example without kick assembly)

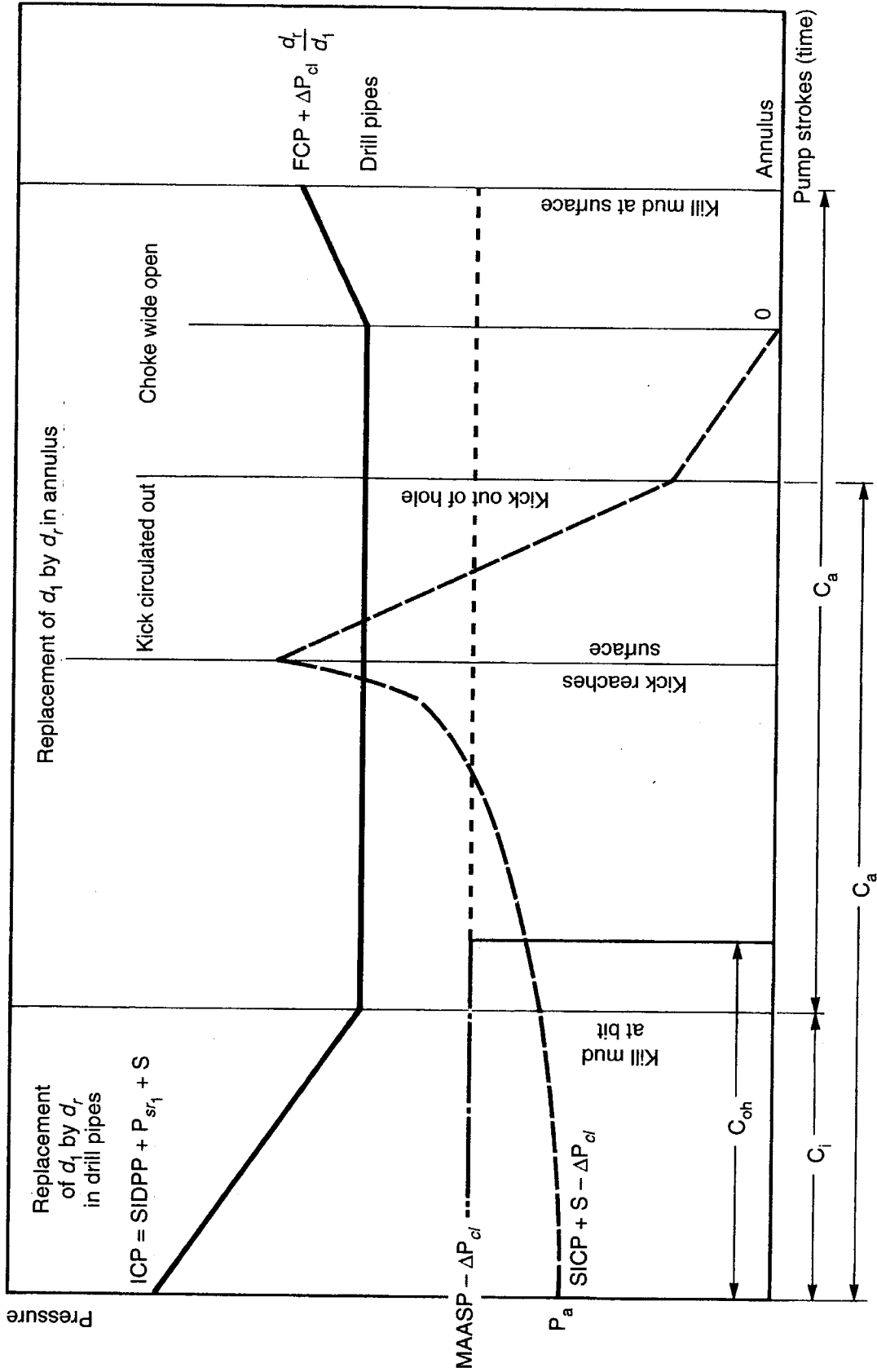

Choke must be adjusted to follow the solid line

CONTROL ON A FLOATING RIG

Control is started with a drill pipe pressure of:

$$ICP = P_{sr_1} + \Delta P_{ka} + SIDPP + S$$

To avoid fracturing at the shoe, the starting annular surface pressure must be:

$$P_a < MAASP - \Delta P_{cl}$$

When the mud of the required weight reaches the bit, the drill pipe pressure is:

$$FCP = (P_{sr_1} + \Delta P_{ka}) \frac{d_r}{d_1}$$

In very deep water, the choke plays the role of a fixed choke. As long as the pressure loss caused by this fixed choke can be offset by opening the adjustable choke, the downhole pressure is unaffected.

As control is completed, with the adjustable choke completely open, the circulating pressure exceeds FCP. To limit this excess, which corresponds to a downhole overpressure of:

$$\Delta P_{cl} \frac{d_r}{d_1}$$

at the end of control, the second choke line can be opened or control completed at a lower flow rate.

(1) ΔP_{ka} : additional pressure loss due to a kick assembly. If fluid circulates through the kelly instead of a kick assembly $\Delta P_{ka} = 0$.

WELL STRENGTH

MAASP

The maximum allowable pressure MAASP at the top of the annulus, well closed, without any risk of fracturing the formation at the weak zone, is related to the specific gravity of the fluid in the annulus between the weak zone and the surface.

The MAASP changes as the fluid specific gravity changes:

$$\text{MAASP} = P_{\text{frac}} - 9.81 Z_s d_1$$

Fracturing specific gravity

$$d_{\text{frac}} = \frac{P_{\text{frac}}}{9.81 Z_s}$$

Maximum allowable gain at shut-in to avoid fracturing at the weak zone

Gas height:

$$h = \frac{\text{MAASP} - (P_f - 9.81 Z d_1)}{9.81 (d_1 - d_g)}$$

d_g is given by the chart on page K 13.

$$G_{\text{max}} = \frac{\text{MAASP} - (P_f - 9.81 Z d_1)}{9.81 (d_1 - d_g)} V_{\text{ab}}$$

Maximum allowable gain at shut-in to avoid exceeding the P_{max} pressure of the well when the gas arrives below the BOP during the circulation of a gas kick:

$$G_{\text{max}} = \frac{P_{\text{max}} [9.81 Z d_1 - (P_f - P_{\text{max}})]}{9.81 K d_1 P_f} V_{\text{ab}}$$

K is given by the chart on page K 13.

Maximum annulus pressure, well shut-in and filled with gas

$$P_{\text{afg}} = P_f - 9.81 Z d_g$$

d_g is given by the chart on page K 13.

WELL STRENGTH (continued)**Maximum casing pressure during the circulation of a gas kick with the initial mud weight**

$$P_{a \max} = \frac{\text{SIDPP}}{2} + \sqrt{\frac{\text{SIDPP}^2}{4} + 9.81 \frac{KGd_1 P_f}{v_a}}$$

K is given by the chart on page K 13.

Note: this pressure is calculated when the gas arrives below the BOP. The geometry of the annulus is considered constant.

Maximum pressure at weak zone during circulation of a gas kick with mud of the original weight

$$P_{s \max} = \frac{\text{SIDPP} + 9.81 Z_s d_1}{2} + \sqrt{\frac{(\text{SIDPP} + 9.81 Z_s d_1)^2}{4} + 9.81 \frac{Gd_1 P_f}{v_a}}$$

Note: this pressure is calculated when the gas arrives below the weak zone. The geometry of the annulus is considered constant. K is equal to 1.

CHARTS GIVING COEFFICIENT K AND GAS SPECIFIC GRAVITY

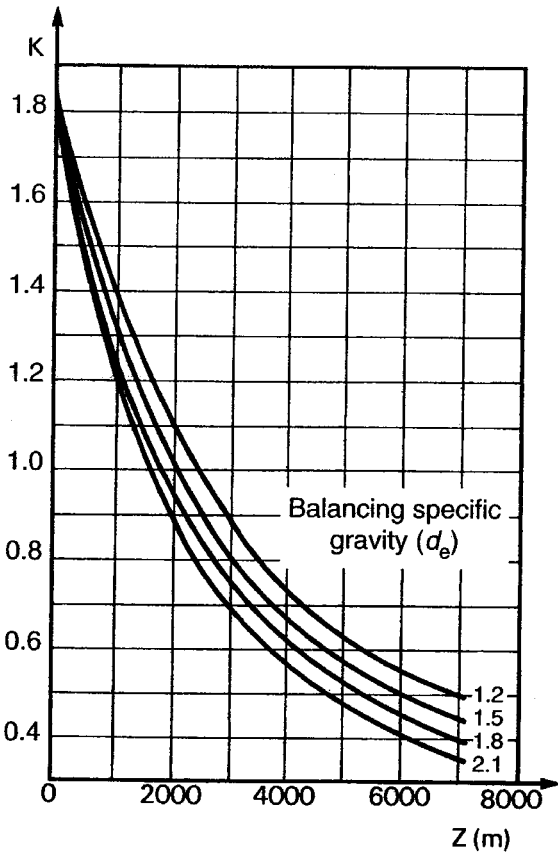

Value of the coefficient K as a function of depth and balancing mud weight for a given formation (coefficient used to calculate maximum circulating casing pressure $P_{a\ max}$ when taking a kick).

From *Blowout Prevention and Well control*, Éditions Technip, Paris, 1981.

Specific gravity of a gas as a function of pressure and temperature (for a gas of average composition (80% C1) specific gravity of 0.675 (air = 1) and a temperature gradient of 3°C/100 m).

From *Blowout Prevention and Well control*, Éditions Technip, Paris, 1981.

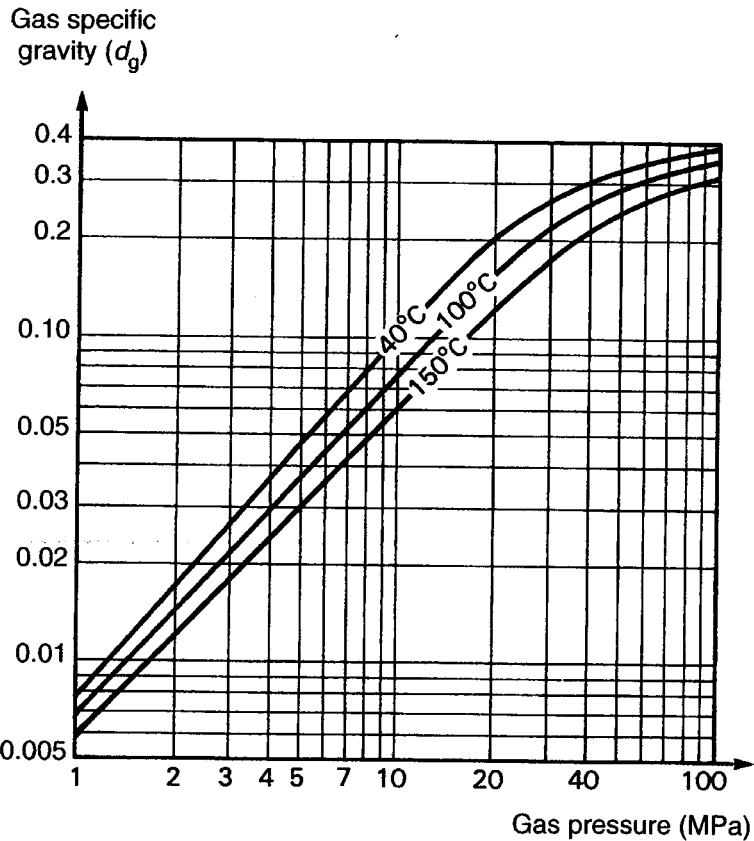

$m \times 3.28 = ft$
 $MPa \times 145 = psi$
 $kg/l = sp.gr.$
 $kg/l \times 8.35 = lb/gal$

EXAMPLE OF KICK CONTROL

I INITIAL DATA

Well depth.....	Z	= 2500 m
Casing size 9 5/8 in (N80-47 lb/ft).....	Z_s	= 1750 m
BOP serie 10 000		
Bit size 8 1/2 in with:		
. 5 in drill pipes, 19.5 lb/ft.....		= 2320 m
. 6 3/4 in - 2 1/4 in drill collars.....		= 180 m
. mud weight.....	d_1	= 1.15
. drilling mud flow rate.....	Q	= 1300 l/min
		(80 strokes/min)
. reduced mud flow rate.....	Q_r	= 650 l/min
		(40 strokes/min)
. pressure losses when drilling.....	P	= 10 900 kPa
. pressure losses with mud d_1 at reduced flow rate.....	P_{sr_1}	= 3500 kPa
Leak Off Test at shoe with mud at d_1	MAASP	= 7700 kPa

II PRELIMINARY CALCULATIONS

Inside volume of drill pipes (9.15 l/m).....	21 228	liters
Inside volume of drill collars (2.565 l/m).....	462	liters
	21 690	liters (1335 strokes)
Annulus casing (38.18 l/m) - drill pipe (13.11 l/m)		
volume.....	43 872	liters
Annulus hole (36.61 l/m) - drill pipe (13.11 l/m)		
volume.....	13 395	liters
Annulus hole (36.61 l/m) - drill collar (23.09 l/m)		
volume.....	2 434	liters
	59 701	liters (3673 strokes)
Total annulus volume V_a	15 829	liters (974 strokes)
Open-hole annulus volume V_{oh}		

Fracture pressure:

$$P_{frac} = MAASP + 9.81 Z_s d_1 = 7700 + 9.81 \times 1750 \times 1.15$$

$$P_{frac} = 27\,440 \text{ kPa}$$

Fracture mud weight :

$$d_{frac} = \frac{P_{frac}}{9.81 Z_s} = \frac{27\,440}{9.81 \times 1750}$$

$$d_{frac} = 1.60$$

III WELL SHUT-IN

After waiting about 15 min for stabilization of the pressures, the readings are:

$$\begin{aligned} \text{SIDPP} &= 2300 \text{ kPa} \\ \text{SICP} &= 4500 \text{ kPa} \\ G &= 4000 \text{ liters} \end{aligned}$$

EXAMPLE OF KICK CONTROL (continued)

IV CALCULATIONS AFTER SHUT-IN

$$P_f = 2300 + 9.81 \times 2500 \times 1.15 = 30\,500 \text{ kPa}$$

Given the difference between MAASP (7700 kPa) and SICP (4500 kPa), the following safety margin is used:

$$S = 1000 \text{ kPa}$$

$$\text{ICP} = 2300 + 3500 + 1000 = 6800 \text{ kPa}$$

$$d_r = 1.15 + \frac{2300 + 1000}{9.81 \times 2500} = 1.29$$

$$\text{FCP} = 3500 \times \frac{1.29}{1.15} = 3925 \text{ kPa}$$

Total volume to be weighted by considering the circulating volume of 80 m³ at the surface:

$$V = V_i + V_a + V_{tk} = 21.690 + 59.701 + 80.000 = 161.4 \text{ m}^3$$

Barite to be added:

$$B = 4.2 \times 161.4 \times \frac{1.29 - 1.15}{4.20 - 1.29} = 32.6 \text{ metric tons}$$

Volume increase due to barite:

$$V_B = \frac{32.6}{4.2} = 7.8 \text{ m}^3$$

V KICK CONTROL BY THE DRILLER'S METHOD

a) After setting the pump strokes counter to zero, open the choke and start the pump at the rate of 650 l/min (40 strokes/min). Adjust the choke to read the casing pressure:

$$P_a = \text{SICP} + S = 4500 + 1000 = 5500 \text{ kPa}$$

b) After a few moments, the drill pipe pressure should stabilize at:

$$\text{ICP} = 6800 \text{ kPa}$$

if not:

- if P_{dp} read < ICP, the pump may be running at **less** than 40 strokes/min: check the pump
- if P_{dp} read > ICP, the pump may be running at **more** than 40 strokes/min: check the pump.

c) When the drill pipe pressure is stabilized at ICP, continue to maintain ICP for at least 3673 strokes.

EXAMPLE OF KICK CONTROL (continued)

d) After 974 strokes, the entire influx has gone into the casing. If the casing pressure then exceeds MAASP, there is no risk of fracture if ICP and Q_r are still constant.

e) After 3673 strokes, (or more if the well is caved in), the influx has been circulated out completely, and you can stop the pump and shut in the well (record the position of the choke before shut-in) to read the pressures. They must be:

$$P_{dp} = \text{SIDPP} = 2300 \text{ kPa}$$

$$P_a = \text{SIDPP} = 2300 \text{ kPa}$$

f) Reset the stroke counter to zero. Restart the pump at 650 l/min (40 strokes/min) repositioning the choke at its value before shut-in, as d_r mud is pumped into the drill pipes.

g) Control the choke to have the following casing pressure:

$$P_a = \text{SIDPP} + S = 2300 + 1000 = 3300 \text{ kPa}$$

The drill pipe pressure should drop from:

$$\text{ICP} = 6800 \text{ kPa} \quad \text{to} \quad \text{FCP} = 3925 \text{ kPa} \text{ in } 1335 \text{ strokes.}$$

h) After 1335 strokes, maintain the drill pipe pressure at:

$$\text{FCP} = 3925 \text{ kPa}$$

until the kill mud d_r reaches the surface.

VI WELL STRENGTH

a. Maximum allowable gain at shut-in to avoid fracturing at weak zone

$$h = \frac{\text{MAASP} - (P_f - 9.81 Z d_1)}{9.81 (d_1 - d_g)}$$

With $P_f = 30\,500 \text{ kPa} = 30.5 \text{ MPa}$ and a downhole temperature of about 80°C , we can take (chart page K 13):

$$d_g = 0.25$$

$$h = \frac{7700 - (30\,000 - 9.81 \times 2500 \times 1.15)}{9.81 \times (1.15 - 0.25)}$$

$$h = 612 \text{ m}$$

or: 180 m opposite the drill collars:	180 × 13.52	=	2 424 liters
432 m opposite the drill pipes:	432 × 23.5	=	10 152 liters
	Gain	=	12 586 liters

Since the maximum allowable gain is less than the open-hole annulus volume, the calculation with the gas-filled well is unacceptable.

EXAMPLE OF KICK CONTROL (continued)

b. Maximum pressure at weak zone (or shoe) during gas circulation

$$P_{s \max} = \frac{\text{SIDPP} + 9.81 Z_s d_1}{2} + \sqrt{\frac{(\text{SIDPP} + 9.81 Z_s d_1)^2}{4} + 9.81 \frac{G d_1 P_f}{v_a}}$$

$$P_{s \max} = \frac{2300 + 9.81 \times 1750 \times 1.15}{2} + \sqrt{\frac{(2300 + 9.81 \times 1750 \times 1.15)^2}{4} + 9.81 \frac{4000 \times 1.15 \times 30\,500}{23.5}}$$

$$P_{s \max} = 24\,439 \text{ kPa} < P_{\text{frac}}$$

At shut-in, the pressure at the weak zone (or shoe):

$$P_s = \text{SICP} + 9.81 Z_s d_1 = 4500 + 9.81 \times 1750 \times 1.15 = 24\,242 \text{ kPa}$$

When circulation is started:

$$P_s = \text{SICP} + S + 9.81 Z_s d_1 = 25\,242 \text{ kPa}$$

$P_{s \max}$ calculated is lower than the value reached when starting control.

This is explained by the moderating effect of the drill collars. The gas height at the shoe is lower than downhole. This is not always the case, especially if the shoe is shallow.

c. Maximum casing pressure when circulating the kick

For $Z = 2500 \text{ m}$ and $d_e = 1.24$, we obtain $K = 0.95$ on the chart on page K 13.

$$P_{a \max} = \frac{\text{SIDPP}}{2} + \sqrt{\frac{\text{SIDPP}^2}{4} + 9.81 \frac{K G d_1 P_f}{v_a}}$$

$$P_{a \max} = \frac{2300}{2} + \sqrt{\frac{2300^2}{4} + 9.81 \frac{0.95 \times 4000 \times 1.15 \times 30\,500}{23.5}}$$

$$P_{a \max} = 8697 \text{ kPa}$$

Value lower than :

(a) The BOP working pressure = 68 950 kPa

(b) The casing bursting pressure = 47 300 kPa

DETERMINATION OF THE LENGTH OF FREE PIPE IN A STUCK STRING

The length of free pipe in a stuck string is given by the formula:

$$L = \frac{2.675 P_{dp} \ell}{T_2 - T_1}$$

where:

L = length of free pipe (m)

P_{dp} = weight per meter of pipe (kg/m)

ℓ = differential stretch in mm for differential pull $T_2 - T_1$ (10^3 daN)

Note: this method does not give high accuracy on L .

EXAMPLE OF HOW TO USE THE METHOD

Sticking at 2247 m in a 8 1/2 in hole with a mud weight 1.40 (SG). The drill string consists of 2000 m of 5 in, 19.50 lb/ft (NC50) grade X95, class Premium drill pipes, 31.83 kg/m and 247 m of 6 3/4 in by 2 13/16 in drill collars, 149.8 kg/m.

First step. Calculate the maximum pull on drill pipe:

(a) Tension load at minimum yield strength = 175.6×10^3 daN.

(b) Maximum allowable pull = $175.6 \times 0.9 = 158 \times 10^3$ daN

Second step. Calculate the weight of the drill string in mud:

(a) Drill collars = $247 \text{ m} \times 149.8 \text{ kg/m} = 37\,000 \text{ kg} \approx 37.0 \times 10^3$ daN

(b) Drill pipes = $2000 \text{ m} \times 31.83 \text{ kg/m} = 63\,600 \text{ kg} \approx 63.6 \times 10^3$ daN

Total $\approx 100.6 \times 10^3$ daN

in mud $d = 1.40$, the buoyancy factor is 0.822.

Weight of drill string in mud = $100.6 \times 0.822 = 82.6 \times 10^3$ daN.

The allowable pull margin is: $158 - 82.6 = 75.4 \times 10^3$ daN.

Third step. Pull on the drill string until the weight indicator shows a pull T_1 of 105×10^3 daN

(1). Draw a mark at the kelly bushing level. Apply 110×10^3 daN and return to 105×10^3 daN. Draw a second mark at the kelly bushing level. This second mark should be distinct from the first (difference caused by friction of drill pipes in the hole). Draw a datum line midway between the two marks.

DETERMINATION OF THE LENGTH OF FREE PIPE IN A STUCK STRING (continued)

Fourth step. Proceed as above by applying $T_2 = 135 \times 10^3$ daN (1). Draw a mark. Pull at 140×10^3 daN and return to 135×10^3 daN. Draw a mark. Draw a datum line midway between these two marks. Measure the distance ℓ in mm between the two datum lines.

Assume $\ell = 700$ mm.

Fifth step. Apply the formula with:

$$P_{dp} = 31.8 \text{ kg/m}$$

$$\ell = 700 \text{ mm}$$

$$T_1 = 105 \times 10^3 \text{ daN}$$

$$T_2 = 135 \times 10^3 \text{ daN}$$

$$L = \frac{2.675 \times 31.8 \times 700}{30} = 1985 \text{ m}$$

Conclusion. The sticking point is nearly at the top of the drill collars.

(1) Examples only.

MAXIMUM ALLOWABLE NUMBER OF TURNS WHICH CAN BE GIVEN TO 1000 m OF NEW DRILL PIPE UNDER A GIVEN AXIAL TENSION (Grade E drill pipe)

Nominal weight and diameter of drill pipe		Number of turns for 1000 m of drill pipe under a tension of (1000 daN)																					
		0	10	20	30	40	50	60	70	80	90	100	110	120	130	140	150	160	170	180	190	200	210
2 3/8	4.85	18 3/4	18 1/4	16 3/4	13 1/2																		
2 3/8	6.65	18 3/4	18 1/2	17 3/4	16 1/4	14 1/4																	
2 7/8	6.85	15 1/2	15 1/4	14 1/2	13 1/2	11 1/2	8 3/4																
2 7/8	10.40	15 1/2	15 1/2	15 1/4	14 3/4	14	13 1/4	12	10 1/2	8 1/2													
3 1/2	9.50	12 3/4	12 3/4	12 1/4	12	11 1/4	10 1/4	9 1/4	7 1/2	4 3/4													
3 1/2	13.30	12 3/4	12 3/4	12 1/2	12 1/4	12	11 1/2	11	10 1/4	9 1/2	8 1/2	7 1/4	5 1/4										
3 1/2	15.50	12 3/4	12 3/4	12 1/2	12 1/2	12 1/4	12	11 1/2	11	10 1/2	10	9	8 1/4	7	5 1/2	2 3/4							
4	11.85	11 1/4	11	11	10 3/4	10 1/4	9 3/4	9	8 1/4	7	5 1/4	2 1/2											
4	14.00	11 1/4	11	11	10 3/4	10 1/2	10 1/4	9 3/4	9 1/4	8 3/4	7 3/4	6 3/4	5 1/2	3 1/2									
4 1/2	13.75	10	9 3/4	9 3/4	9 1/2	9 1/4	9	8 1/2	8	7 1/2	6 1/2	5 1/2	4										
4 1/2	16.60	10	9 3/4	9 3/4	9 3/4	9 1/2	9 1/4	9	8 3/4	8 1/4	7 3/4	7 1/4	6 1/2	5 3/4	4 1/2	3							
4 1/2	20.00	10	10	9 3/4	9 3/4	9 3/4	9 1/2	9 1/4	9 1/4	9	8 1/2	8 1/4	8	7 1/2	7	6 1/2	5 3/4	4 3/4	3 3/4	1 3/4			
5	19.50	9	9	8 3/4	8 3/4	8 3/4	8 1/2	8 1/4	8 1/4	8	7 3/4	7 1/4	7	6 1/2	6	5 1/2	4 3/4	3 3/4	2 1/4				
5	25.60	9	9	8 3/4	8 3/4	8 3/4	8 3/4	8 1/2	8 1/2	8 1/4	8 1/4	8	7 3/4	7 3/4	7 1/2	7 1/4	6 1/4	6 1/2	6 1/4	5 3/4	5 1/4	4 3/4	4
5 1/2	21.90	8	8	8	8	8	7 3/4	7 3/4	7 1/2	7 1/2	7 1/4	7	6 3/4	6 1/4	6	5 1/2	5 1/4	4 1/2	4	3			
5 1/2	24.70	8	8	8	8	8	8	7 3/4	7 3/4	7 1/2	7 1/2	7 1/4	7	6 3/4	6 1/2	6 1/4	6	5 1/2	5 1/4	4 3/4	4 1/4	3 1/2	2 1/2
6 5/8	25.20	6 3/4	6 3/4	6 3/4	6 3/4	6 1/2	6 1/2	6 1/2	6 1/4	6 1/4	6	6	5 3/4	5 1/2	5 1/2	5 1/4	4 3/4	4 1/2	4 1/4	3 3/4	3 1/4	2 3/4	1 3/4
6 5/8	27.70	6 3/4	6 3/4	6 3/4	6 3/4	6 1/2	6 1/2	6 1/2	6 1/2	6 1/2	6 1/4	6	6	5 3/4	5 1/2	5 1/2	5 1/4	5	4 3/4	4 1/2	4	3 1/2	3 1/4

daN x 2.25 = lb m x 3.28 = ft

Note: Tabulated values are based on the following formula:
$$N = \frac{100LS}{\pi DG} \sqrt{1 - \frac{100T^2}{3A^2S^2}}$$

- where:
- N = number of turns which can be given for a tensile load T (daN)
 - L = length of drill pipe string (m)
 - S = maximum shear strength (MPa). S is 57.7% of the minimum yield strength (grade)
 - D = outside diameter of drill pipe (cm)
 - G = modulus of elasticity in shear: 84 000 MPa
 - T = total tensile load (daN)
 - A = pipe cross-sectional area (mm²).

MAXIMUM ALLOWABLE NUMBER OF TURNS WHICH CAN BE GIVEN TO 1000 m OF NEW DRILL PIPE UNDER A GIVEN AXIAL TENSION (Grade X95 drill pipe)

Number of turns for 1000 m of drill pipe under a tension of (1000 daN)

Nominal weight and diameter of drill pipe (in)	0	10	20	30	40	50	60	70	80	90	100	110	120	130	140	150	160	170	180	190	200	210
2 3/8	4.85	23 3/4	23 1/4	22	20	16 1/4	10															
2 3/8	6.65	23 3/4	23 1/2	22	20 1/4	18 1/4	15 1/4	10 1/2														
2 7/8	6.85	19 1/2	19 1/2	19	18	16 3/4	14 3/4	8														
2 7/8	10.40	19 1/2	19 1/2	19 1/4	19	18 1/2	17 3/4	16	14 3/4	13	11	8	2 1/4									
3 1/2	9.50	16	15 3/4	15 1/2	15	14 1/4	13 1/2	12 1/2	11	9 1/4	6 1/2											
3 1/2	13.30	16	16	15 3/4	15 1/2	15 1/4	14 3/4	14 1/4	13 3/4	13	12 1/4	11 1/4	10	8 1/2	6 1/2	3 1/4						
3 1/2	15.50	16	16	16	15 3/4	15 1/2	15 1/4	14 3/4	14 1/2	14	13 1/2	12 3/4	12	11 1/4	10 1/4	9	7 3/4	5 3/4	2 1/4			
4	11.85	14	14	13 1/2	13 1/2	13	12 1/2	12	11	10	9	7 1/2	5 1/2									
4	14.00	14	14	13 3/4	13 3/4	13 1/2	13	12 3/4	12 1/4	11 3/4	11	10 1/4	9 1/4	8 1/4	7	5	1 1/4					
4 1/2	13.75	12 1/2	12 1/2	12 1/4	12	11 3/4	11 1/2	11	10 3/4	10	9 1/2	8 3/4	7 3/4	6 1/2	5	2						
4 1/2	16.60	12 1/2	12 1/2	12 1/4	12	11 3/4	11 1/2	11	10 3/4	10 1/4	10	9 1/2	9 1/2	9	8 1/4	7 1/2	6 1/2	5	3 1/4			
4 1/2	20.00	12 1/2	12 1/2	12 1/2	12 1/4	12 1/4	12	12	11 3/4	11 1/2	11 1/4	11	10 3/4	10 1/2	10	9 1/2	9	8 1/2	8	7 1/4	6 1/4	5 1/4
5	19.50	11 1/4	11 1/4	11 1/4	11	11	10 3/4	10 3/4	10 1/2	10 1/4	10	9 3/4	9 1/2	9 1/4	8 3/4	8 1/4	7 3/4	7 1/4	6 3/4	6	5	3 3/4
5	25.60	11 1/4	11 1/4	11 1/4	11 1/4	11 1/4	11	11	10 3/4	10 3/4	10 3/4	10 1/2	10 1/4	10 1/4	10	9 3/4	9 1/2	9 1/4	9	8 3/4	8 1/4	8
5 1/2	21.90	10 1/4	10 1/4	10 1/4	10	10	10	9 3/4	9 3/4	9 1/2	9 1/4	9 1/4	9	8 3/4	8 1/2	8 1/4	7 3/4	7 1/2	7	6 1/2	6	5 1/4
5 1/2	24.70	10 1/4	10 1/4	10 1/4	10 1/4	10 1/4	10	10	9 3/4	9 3/4	9 1/2	9 1/2	9 1/4	9	8 3/4	8 3/4	8 1/2	8 1/4	7 3/4	7 1/2	7 1/4	6 3/4
6 5/8	25.20	8 1/2	8 1/2	8 1/2	8 1/2	8 1/2	8 1/4	8 1/4	8 1/4	8	8	7 3/4	7 3/4	7 1/2	7 1/4	7 1/4	7	6 3/4	6 1/2	6 1/4	5 3/4	5 1/2
6 5/8	27.70	8 1/2	8 1/2	8 1/2	8 1/2	8 1/2	8 1/4	8 1/4	8 1/4	8	8	8	7 3/4	7 3/4	7 1/2	7 1/2	7 1/4	7	6 3/4	6 1/2	6 1/4	6

daN x 2.25 = lb m x 3.28 = ft

Note: Tabulated values are based on the following formula: $N = \frac{100LS}{\sqrt{DGS}} \sqrt{1 - \frac{100T^2}{3A^2S^2}}$

- where:
- N = number of turns which can be given for a tensile load T (daN)
- L = length of drill pipe string (m)
- S = maximum shear strength (MPa). S is 57.7% of the minimum yield strength (grade)
- D = outside diameter of drill pipe (cm)
- G = modulus of elasticity in shear: 84 000 MPa
- T = total tensile load (daN)
- A = pipe cross-sectional area (mm²).

MAXIMUM ALLOWABLE NUMBER OF TURNS WHICH CAN BE GIVEN TO 1000 m OF NEW DRILL PIPE UNDER A GIVEN AXIAL TENSION (Grade G105 drill pipe)

Nominal weight and diameter of drill pipe		Number of turns for 1000 m of drill pipe under a tension of (1000 daN)																					
		0	10	20	30	40	50	60	70	80	90	100	110	120	130	140	150	160	170	180	190	200	210
2 3/8	4.85	26 1/4	26	24 3/4	22 3/4	19 3/4	15	4 1/2															
2 3/8	6.65	26 1/4	26	25 1/2	24 1/2	23 1/4	21 1/4	18 3/4	15 1/4	9 3/4													
2 7/8	6.85	21 3/4	21 1/2	21	20 1/4	19	17 1/2	15 1/4	12 1/4	7													
2 7/8	10.40	21 3/4	21 1/2	21 1/2	21	20 3/4	20	19 1/4	18 1/2	17 1/4	16	14 1/4	12 1/4	9 1/2	5								
3 1/2	9.50	17 3/4	17 3/4	17 1/2	17 1/4	16 3/4	16 1/4	15 1/2	14 1/2	13 1/4	12	10	7 1/2	2 1/4									
3 1/2	13.30	17 3/4	17 3/4	17 3/4	17 1/2	17 1/4	17	16 3/4	16 1/4	15 3/4	15	14 1/4	13 1/2	11 1/2	10	8 1/4	5 3/4						
3 1/2	15.50	17 3/4	17 3/4	17 3/4	17 1/2	17 1/4	17	17	16 3/4	16 1/4	16	15 1/2	15	14 1/4	13 1/2	12 3/4	10 3/4	8	5 3/4				
4	11.85	15 1/2	15 1/2	15 1/2	15 1/4	15	14 1/2	14 1/4	13 1/2	13	12 1/4	11 1/4	10	8 1/2	6 1/2	3 1/2							
4	14.00	15 1/2	15 1/2	15 1/2	15 1/4	15	14 3/4	14 3/4	14 1/4	14	13 1/2	12 3/4	12 1/4	11 1/2	10 1/2	9 1/2	8 1/4	6 3/4	4 1/2				
4 1/2	13.75	13 3/4	13 3/4	13 3/4	13 3/4	13 1/2	13 1/4	13	12 1/2	12 1/4	12 1/4	11 3/4	11 1/4	10 1/2	9 3/4	8 3/4	7 3/4	6 3/4	5 1/4	3 1/4			
4 1/2	16.60	13 3/4	13 3/4	13 3/4	13 3/4	13 1/2	13 1/2	13 1/4	13	12 3/4	12 1/2	12	11 3/4	11 1/4	10 3/4	10 1/4	9 1/2	8 3/4	7 3/4	5 1/4	3 1/4		
4 1/2	20.00	13 3/4	13 3/4	13 3/4	13 3/4	13 3/4	13 1/2	13 1/2	13 1/4	13 1/4	13	12 3/4	12 1/2	12 1/4	12	11 1/2	11 1/4	10 3/4	10 1/4	9 3/4	9 1/4	8 3/4	8...
5	19.50	12 1/2	12 1/2	12 1/2	12 1/4	12 1/4	12 1/4	12	12	11 3/4	11 1/2	11 1/2	11 1/4	11	10 1/2	10 1/4	9 1/2	8 1/2	8	7 1/4	6 1/2		
5	25.60	12 1/2	12 1/2	12 1/2	12 1/2	12 1/4	12 1/4	12 1/4	12 1/4	12	12	12	11 3/4	11 1/2	11 1/2	11 1/4	11	10 3/4	10 1/2	10 1/4	10	9 1/2	
5 1/2	21.90	11 1/4	11 1/4	11 1/4	11 1/4	11 1/4	11 1/4	11	11	10 3/4	10 3/4	10 1/2	10 1/4	10	9 3/4	9 1/4	9 1/2	8 3/4	8 1/2	8	7 3/4	7 1/4	
5 1/2	24.70	11 1/4	11 1/4	11 1/4	11 1/4	11 1/4	11 1/4	11	11	10 3/4	10 3/4	10 1/2	10 1/2	10 1/4	10	9 3/4	9 3/4	9 1/2	9 1/4	9	8 3/4	8 1/4	
6 5/8	25.20	9 1/2	9 1/2	9 1/2	9 1/4	9 1/4	9 1/4	9 1/4	9 1/4	9 1/4	9	9	8 3/4	8 3/4	8 1/2	8 1/4	8	7 3/4	7 1/2	7 1/4	7	6 3/4	
6 5/8	25.20	9 1/2	9 1/2	9 1/2	9 1/4	9 1/4	9 1/4	9 1/4	9 1/4	9 1/4	9	9	9	8 3/4	8 3/4	8 1/2	8 1/2	8 1/4	8	7 3/4	7 1/2	7 1/4	

daN x 2.25 = lb m x 3.28 = ft

Note: Tabulated values are based on the following formula: $N = \frac{100LS}{\pi D G} \sqrt{1 - \frac{100T^2}{3A^2S^2}}$

where:

N = number of turns which can be given for a tensile load T (daN)

L = length of drill pipe string (m)

S = maximum shear strength (MPa). S is 57.7% of the minimum yield strength (grade)

D = outside diameter of drill pipe (cm)

G = modulus of elasticity in shear: 84 000 MPa

T = total tensile load (daN)

A = pipe cross-sectional area (mm²).

MAXIMUM ALLOWABLE NUMBER OF TURNS WHICH CAN BE GIVEN TO 1000 m OF NEW DRILL PIPE UNDER A GIVEN AXIAL TENSION (Grade S135 drill pipe)

Nominal weight and diameter of drill pipe		Number of turns for 1000 m of drill pipe under a tension of (1000 daN)																					
		0	10	20	30	40	50	60	70	80	90	100	110	120	130	140	150	160	170	180	190	200	210
2 3/8	4.85	33 3/4	33 1/2	32 1/2	31 1/4	29	26	21 3/4	15														
2 3/8	6.65	33 3/4	33 1/2	33 1/4	32 1/2	31 1/2	30	28 1/4	26	23 1/4	19 1/2	14 1/2											
2 7/8	6.85	27 3/4	27 3/4	27 1/2	26 3/4	26	24 3/4	23 1/4	21 1/4	18 3/4	15 1/2	11											
2 7/8	10.40	27 3/4	27 3/4	27 3/4	27 1/2	27	26 3/4	26	25 1/2	24 3/4	23 3/4	22 3/4	21 1/2	20	18 1/4	16	13 1/2	10	3 3/4				
3 1/2	9.50	23	22 3/4	22 3/4	22 1/2	22	21 3/4	21	20 1/2	19 3/4	18 3/4	17 1/2	16 1/4	14 1/2	12 1/2	10	6						
3 1/2	13.30	23	22 3/4	22 3/4	22 3/4	22 1/2	22 1/4	22	21 3/4	21 1/4	20 3/4	20 1/4	19 3/4	19	18 1/4	17 1/2	16 1/2	15 1/2	14 1/4	12 3/4	11	9	6
3 1/2	15.50	23	23	22 3/4	22 3/4	22 1/2	22 1/2	22 1/4	22	21 3/4	21 1/2	21	20 3/4	20 1/4	19 3/4	19 1/4	18 3/4	18	17 1/4	16 1/2	15 1/2	14 1/2	13 1/4
4	11.85	20	20	20	19 3/4	19 1/2	19 1/4	19	18 1/2	18	17 1/2	16 3/4	16	15 1/4	14 1/4	13	11 3/4	10	7 3/4	4 1/2			
4	14.00	20	20	20	19 3/4	19 3/4	19 1/2	19 1/4	19	18 3/4	18 1/2	18	17 1/2	17	16 1/2	15 3/4	15	14 1/4	13 1/4	12 1/4	11	9 3/4	7 3/4
4 1/2	13.75	17 3/4	17 3/4	17 3/4	17 3/4	17 1/2	17 1/4	17	16 3/4	16 1/2	16 1/4	15 3/4	15 1/4	14 3/4	14 1/4	13 1/2	12 3/4	12	11	9 3/4	8 1/2	6 3/4	4 1/4
4 1/2	16.60	17 3/4	17 3/4	17 3/4	17 1/2	17 1/2	17 1/2	17 1/4	17 1/4	17	16 3/4	16 1/2	16 1/4	15 3/4	15 1/2	15	14 3/4	14 1/4	13 3/4	13	12 1/2	11 3/4	10 3/4
4 1/2	20.00	17 3/4	17 3/4	17 3/4	17 3/4	17 1/2	17 1/2	17 1/2	17 1/2	17 1/4	17 1/4	17	16 3/4	16 1/2	16 1/4	16	15 3/4	15 1/2	15 1/4	15	14 1/2	14 1/4	13 3/4
5	19.50	16	16	16	16	16	15 3/4	15 3/4	15 3/4	15 1/2	15 1/4	15 1/4	15	14 3/4	14 1/2	14 1/4	14	13 3/4	13 1/2	13 1/4	12 3/4	12 1/2	12
5	25.60	16	16	16	16	16	16	15 3/4	15 3/4	15 3/4	15 3/4	15 1/2	15 1/2	15 1/4	15 1/4	15	14 3/4	14 3/4	14 1/2	14 1/4	14 1/4	14 1/4	14
5 1/2	21.90	14 1/2	14 1/2	14 1/2	14 1/2	14 1/2	14 1/2	14 1/4	14 1/4	14 1/4	14	14	13 3/4	13 3/4	13 1/2	13 1/4	13	12 3/4	12 1/2	12 1/2	12 1/4	12	11 3/4
5 1/2	24.70	14 1/2	14 1/2	14 1/2	14 1/2	14 1/2	14 1/2	14 1/2	14 1/4	14 1/4	14 1/4	14	14	13 3/4	13 3/4	13 1/2	13 1/4	13	12 3/4	12 1/2	12 1/2	12 1/4	12 1/4
6 5/8	25.20	12	12	12	12	12	12	12	12	11 3/4	11 3/4	11 3/4	11 3/4	11 1/2	11 1/2	11 1/4	11	11	10 3/4	10 1/2	10 1/2	10 1/4	10 1/4
6 5/8	27.70	12	12	12	12	12	12	12	12	12	11 3/4	11 3/4	11 3/4	11 1/2	11 1/2	11 1/4	11	11	11	10 3/4	10 3/4	10 3/4	10 1/2

daN x 2.25 = lb m x 3.28 = ft

Note: Tabulated values are based on the following formula: $N = \frac{100LS}{\sqrt{IDG}} \sqrt{1 - \frac{100T^2}{3A^2S^2}}$

- where:
- N = number of turns which can be given for a tensile load T (daN)
 - L = length of drill pipe string (m)
 - S = maximum shear strength (MPa). S is 57.7% of the minimum yield strength (grade)
 - D = outside diameter of drill pipe (cm)
 - G = modulus of elasticity in shear: 84 000 MPa
 - T = total tensile load (daN)
 - A = pipe cross-sectional area (mm²).

BACK-OFF

- 1) Before any back-off, determine the depth of the stuck point using an extensometer or by the stretch test (see K 18).
- 2) Make-up the drill string to a maximum of 80% of the torsional limit (see K 20 to K 23).
- 3) Set the neutral point at the level of the joint to back-off.

The tension on the Martin Decker is given by:

$$T = P + \frac{HP \times S}{100\,000}$$

where:

T = weight indicator tension (10^3 daN)

P = weight in mud of free length of drill pipe plus travelling block, hook, etc. (10^3 daN)

HP = hydrostatic pressure at back-off point (kPa)

S = area of matting surface of tool joint (cm^2) (see K 25)

- 4) Apply leftward twist amounting to 60 to 80% of the rightward twist used to make-up the string.

Example: Back-off at 2000 m of a 5 in string, 19.50 lb/ft (NC50), class Premium, grade X95 drill pipe, in a hole containing mud with SG = 1.40. Weight of travelling block and accessories: 8×10^3 daN (see K 18).

Calculations:

Weight per meter of drill pipe = 31.83 kg/m

Buoyancy factor = 0.822

Weight per meter of drill pipe in mud = $31.83 \times 0.822 = 26.16$ kg/m

Weight of 2000 m of drill pipe in mud = $2000 \times 26.16 \approx 52 \times 10^3$ daN

Hydrostatic pressure at 2000 m HP = $9.81 \times 2000 \times 1.4 \approx 28\,000$ kPa

Area of matting surface of tool-joint (see K 25) $S = 34.73$ cm^2 .

First step. Make-up the drill string to 80% of the torsional limit of the drill pipes in tension. The weight of the drill string, before sticking, was 90×10^3 daN on the weight indicator, or $90 - 8 = 82 \times 10^3$ daN for the drill string only. For 80×10^3 daN, page K 21 indicates a maximum number of turns of 10 1/2 per 1000 m of drill pipe, or 21 turns for 2000 m. Make-up the drill string with 80% of 21 turns, or 16 turns of the right.

Second step. Set the neutral point at 2000 m. The weight indicator should show:

$$T = P + \frac{HP \times S}{100\,000} \quad \text{with: } P = 52 + 8 = 60 \quad \text{and: } \frac{HP \times S}{100\,000} = \frac{28\,000 \times 34.73}{100\,000} = 10$$

$$T = 60 + 10 = 70 \times 10^3 \text{ daN}$$

Third step. Twist to the left to 80% of the rightward twist given above, or 80% of 16 turns or 13 turns.

**TOOL JOINT MATTING
SURFACE AREA
(API Spec 7, April 1, 1994)**

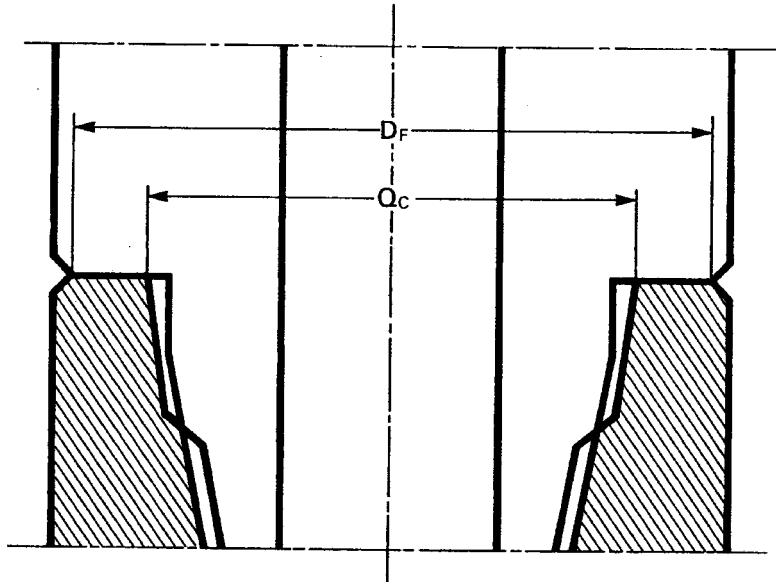

Type of connection	Bevel diameter D_F		Inside diameter Q_C		Matting surface area	
	(mm)	(in)	(mm)	(in)	(mm ²)	(in ²)
NC23	76.2	3	66.7	2 5/8	1 066	1.653
NC26	82.9	3 17/64	74.6	2 15/16	1 027	1.591
NC31	100.4	3 61/64	87.7	3 29/64	1 876	2.908
NC35	114.7	4 33/64	96.8	3 13/16	2 973	4.609
NC38	116.3	4 37/64	103.6	4 5/64	2 193	3.400
NC40	127.4	5 1/64	110.3	4 11/32	3 192	4.948
NC44	144.5	5 11/16	119.1	4 11/16	5 259	8.151
NC46	145.3	5 23/32	124.6	4 29/32	4 388	6.801
NC50	150.4	5 59/64	134.9	5 5/16	3 473	5.383
NC50 (1)	154.0	6 1/16	134.9	5 5/16	4 334	6.717
NC56	185.3	7 19/64	150.8	5 15/16	9 107	14.116
NC61	212.7	8 3/8	165.1	6 1/2	14 124	21.892
NC70	232.6	9 5/32	187.3	7 3/8	14 939	23.156
NC77	260.7	9 11/32	204.8	8 1/16	20 437	31.678
2 3/8 REG	76.6	3 1/64	68.3	2 11/16	945	1.464
2 7/8 REG	91.7	3 39/64	77.8	3 1/16	1 850	2.868
3 1/2 REG	104.4	4 7/64	90.5	3 9/16	2 128	3.298
4 1/2 REG	135.3	5 21/64	119.1	4 11/16	3 237	5.017
5 1/2 REG	165.1	6 1/2	141.7	5 37/64	5 638	8.740
6 5/8 REG	186.9	7 23/64	154.0	6 1/16	8 809	13.654
7 5/8 REG	215.1	8 15/32	180.2	7 3/32	10 835	16.795
8 5/8 REG	242.5	9 35/64	204.4	8 3/64	13 373	20.728
5 1/2 FH	170.7	6 23/32	150.0	5 29/32	5 214	8.081
6 5/8 FH	195.7	7 45/64	173.8	6 27/32	6 355	9.851

(1) Standard for all NC50 connections manufactured after June 1986.

L

wellheads

API flanges. Working pressure as a function of nominal size (API Spec 6A, 17 th edition, February 1, 1996).....	L1
Physical properties of steel for wellheads (PSL 1 to 4) API Spec 6A, 17 th edition, February 1, 1996).....	L2
Minimum vertical full-opening body bores and maximum casing sizes (API Spec 6A, 17 th edition, February 1, 1996).....	L3
API type 6B flanges. Working pressure 2000 psi (13.8 MPa) (API Spec 6A, 17 th edition, February 1, 1996)	L4
API type 6B flanges. Working pressure 3000 psi (20.7 MPa) (API Spec 6A, 17 th edition, February 1, 1996).....	L5
API type 6B flanges. Working pressure 5000 psi (34.5 MPa) (API Spec 6A, 17 th edition, February 1, 1996).....	L6
API type 6BX flanges. Working pressures: 2000 psi (13.8 MPa), 3000 psi (20.7 MPa), 5000 psi (34.5 MPa) and 10 000 psi (69 MPa) (API Spec 6A, 17 th edition, February 1, 1996).....	L7
API type 6BX flanges. Working pressures: 2000 psi (13.8 MPa), 3000 psi (20.7 MPa), 5000 psi (34.5 MPa) and 10 000 psi (69 MPa) (API Spec 6A, 17 th edition, February 1, 1996).....	L8

API type 6BX flanges. Working pressure: 15 000 psi (103.5 MPa), (API Spec 6A, 17 th edition, February 1, 1996).....	L9
API type 6BX flanges. Working pressures: 20 000 psi (138 MPa), (API Spec 6A, 17 th edition, February 1, 1996).....	L10
API Type R ring-joint gaskets. (API Spec 6A, 17 th edition, February 1, 1996).....	L11
API Type RX ring-joint gaskets (API Spec 6A, 17 th edition, February 1, 1996).....	L12
API Type BX ring-joint gaskets. (API Spec 6A, 17 th edition, February 1, 1996).....	L13
Recommended flange bolt torque.....	L14
API Type 16B integral hub connections (API Spec 6A, 1 st edition, November 1, 1986).....	L15-L17
Clamp for flanges. Clamp dimensions (Cameron).....	L18
CIW clamp for flanges. Make-up torque on bolts of CIW clamps.....	L19
Cameron Ram-Type blow-out preventers Operating data.....	L20
Hydril Ram-Type blow-out preventers Operating data.....	L21-L22
NL Shaffer blow-out preventers. Operating data.....	L23
Koomey Ram-Type blow-out preventers. Operating data.....	L24
Cameron ram-type blow-out preventers. Dimensions and weights.....	L25
Hydril ram-type blow-out preventers. Dimensions and weights.....	L26
NL Shaffer ram-type blow-out preventers. Dimensions and weights.....	L27-L29

Koomey ram-type blow-out preventers. Dimensions and weights.....	L30-L31
Cameron type D annular blow-out preventers . Dimensions and operating data.....	L32
Hydril annular blow-out preventers. Dimensions and operating data.....	L33-L34
Hydril annular blow-out preventers. Average closing pressure (psi) required to establish initial seal-off in a surface installation.....	L35-L37
NL Shaffer annular blow-out preventers. Dimensions and operating data. Closing pressure on casing (psi).....	L38
BOP control system. Example of calculations for fluid capacity (IADC Drilling Manual, 11 th edition, 1992).....	L39-L41
Schematic symbols for fluid power diagrams (Bases on ANSI Y.32.10) (API Spec 16D, 1 st edition, March 1, 1993).....	L42-L46

API FLANGES
Working pressure as a function of nominal size
(API Spec 6A, 17th edition, February 1, 1996)

Working pressure		Nominal size (in)			
		Type 6B		Type 6BX	
(psi)	(MPa)	(in)	(mm)	(in)	(mm)
2 000	13.8	2 1/16 to 21 1/4	52 to 540	26 3/4 to 30	680 to 762
3 000	20.7	2 1/16 to 20 3/4	52 to 527	26 3/4 to 30	680 to 762
5 000	34.5	2 1/16 to 11	52 to 279	13 5/8 to 21 1/4	346 to 540
10 000	69.0			1 13/16 to 21 1/4	46 to 540
15 000	103.4			1 13/16 to 18 3/4	46 to 476
20 000	138.0			1 13/16 to 13 5/8	46 to 346

PHYSICAL PROPERTIES OF STEEL FOR WELLHEADS (PSL 1 to 4)

(API Spec 6A, 17th edition, February 1, 1996)

API material property requirements for bodies, bonnets and end and outlet connections

API material designation	0.2% yield strength Minimum, psi (MPa)	Tensile strength, Minimum, psi (MPa)	Elongation in 2 in (50 mm), Minimum (%)	Reduction in area, Minimum (%)
36K	36 000 (248)	70 000 (483)	21	No Requirement
45K	45 000 (310)	70 000 (483)	19	32
60K	60 000 (414)	85 000 (586)	18	35
75K	75 000 (517)	95 000 (655)	17	35

API material applications for bodies, bonnets, and end and outlet connections

Part	Pressure ratings, psi (MPa)					
	2 000 (13.8)	3 000 (20.7)	5 000 (34.5)	10 000 (69.0)	15 000 (103.4)	20 000 (138.0)
Body*, Bonnet	API material designation					
Integral end connection	36K, 45K 60K, 75K	36K, 45K 60K, 75K	36K, 45K 60K, 75K	36K, 45K 60K, 75K	45K, 60K 75K	60K, 75K
Flanged	60K, 75K	60K, 75K	60K, 75K	60K, 75K	75K	75K
Threaded	60K, 75K	60K, 75K	60K, 75K	60K, 75K	NA	NA
Other	(See note)	(See note)	(See note)	(See note)	(See note)	(See note)
Loose connectors						
Weld neck	45K	45K	45K	60K, 75K	75K	75K
Blind	60K, 75K	60K, 75K	60K, 75K	60K, 75K	75K	75K
Threaded	60K, 75K	60K, 75K	60K, 75K	NA	NA	NA
Other	(See note)	(See note)	(See note)	(See note)	(See note)	(See note)

Note: As specified by the manufacturer.

* Provided end connections are of the API material designation indicated, welding is done in accordance with Section 6 and design is performed in accordance with Section 4.

MINIMUM VERTICAL FULL-OPENING BODY BORES AND MAXIMUM CASING SIZES (API Spec 6A, 17th edition, February 1, 1996)

Nominal flange				Casing beneath body					Minimum vertical full-opening wellheads body bore	
Nominal size and bore of flange		Rated working pressure		Size outside diameter		Nominal weight	Specified drift diameter			
(in)	(mm)	(psi)	(MPa)	(in)	(mm)	(lb/ft)	(in)	(mm)	(in)	(mm)
7 1/16	179.39	2 000	13.8	7	177.80	17.0	6.413	162.9	6.45	163.8
		3 000	20.7	7	177.80	20.0	6.331	160.8	6.36	161.5
		5 000	34.5	7	177.80	23.0	6.241	158.5	6.28	159.5
7 1/16	179.39	10 000	68.9	7	177.80	29.0	6.059	153.9	6.09	154.7
		15 000	103.4	7	177.80	38.0	5.795	147.2	5.83	148.1
		20 000	137.9	7	177.80	38.0	5.795	147.2	5.83	148.1
9	228.60	2 000	13.8	8 5/8	219.08	24.0	7.972	202.5	8.00	203.2
		3 000	20.7	8 5/8	219.08	32.0	7.796	198.0	7.83	198.9
		5 000	34.5	8 5/8	219.08	36.0	7.700	195.6	7.73	196.3
9	228.60	10 000	68.9	8 5/8	219.08	40.0	7.600	193.0	7.62	193.5
		15 000	103.4	8 5/8	219.08	49.0	7.386	187.6	7.41	188.2
		2 000	13.8	10 3/4	273.05	40.5	9.894	251.3	9.92	252.0
11	279.40	3 000	20.7	10 3/4	273.05	40.5	9.894	251.3	9.92	252.0
		5 000	34.5	10 3/4	273.05	51.0	9.694	246.2	9.73	247.1
11	279.40	10 000	68.9	9 5/8	244.48	53.5	8.379	212.8	8.41	213.6
		15 000	103.4	9 5/8	244.48	53.5	8.379	212.8	8.41	213.6
13 5/8	346.08	2 000	13.8	13 3/8	339.73	54.5	12.459	316.5	12.50	317.5
		3 000	20.7	13 3/8	339.73	61.0	12.359	313.9	12.39	314.7
13 5/8	346.08	5 000	34.5	13 3/8	339.73	72.0	12.191	309.7	12.22	310.4
13 5/8	346.08	10 000	68.9	11 3/4	298.45	60.0	10.616	269.6	10.66	270.8
16 3/4	425.45	2 000	13.8	16	406.40	65.0	15.062	382.6	15.09	383.3
		3 000	20.7	16	406.40	84.0	14.822	376.5	14.86	377.4
16 3/4	425.45	5 000	34.5	16	406.40	84.0	14.822	376.5	14.86	377.4
		10 000	68.9	16	406.40	84.0	14.822	376.5	14.86	377.4
18 3/4	476.25	5 000	34.5	18 5/8	473.08	87.5	17.567	446.2	17.59	446.8
		10 000	68.9	18 5/8	473.08	87.5	17.567	446.2	17.59	446.8
20 3/4	527.05	3 000	20.7	20	508.00	94.0	18.936	481.0	18.97	481.8
21 1/4	539.75	2 000	13.8	20	508.00	94.0	18.936	481.0	18.97	481.8
21 1/4	539.75	5 000	34.5	20	508.00	94.0	18.936	481.0	18.97	481.8
		10 000	68.9	20	508.00	94.0	18.936	481.0	18.97	481.8

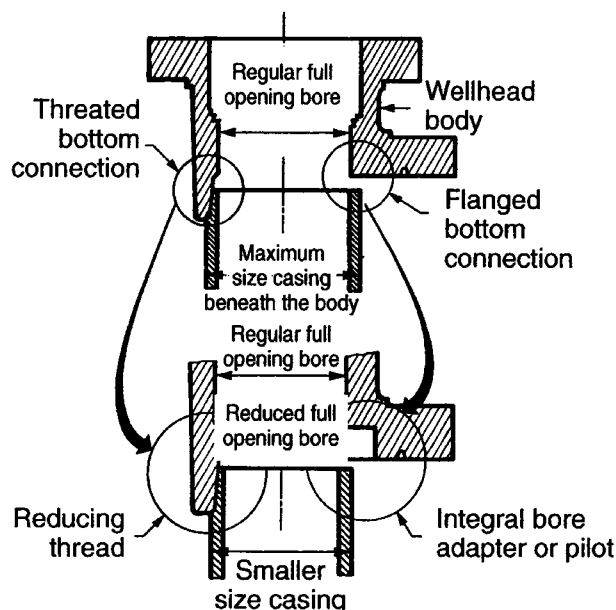

API TYPE 6B FLANGES

Working pressure 2000 psi (13.8 MPa)
(API Spec 6A, 17th edition, February 1, 1996)

Nominal size	Maximum bore B		Outside diameter OD		Diameter of raised face K		Total thickness T		Minimum thickness Q		Diameter of hub X	
	(in)	(mm)	(in)	(mm)	(in)	(mm)	(in)	(mm)	(in)	(mm)	(in)	(mm)
2.0625	2.09	53.09	6.50	165.10	4.25	107.95	1.31	33.27	1.00	25.40	3.31	84.07
2.5625	2.59	65.79	7.50	190.50	5.00	127.00	1.44	36.58	1.12	28.45	3.94	100.08
3.1250	3.22	81.79	8.25	209.55	5.75	146.05	1.56	39.62	1.25	31.75	4.62	117.35
4.0625	4.28	108.71	10.75	273.05	6.88	174.75	1.81	45.97	1.50	38.10	6.00	152.40
7.0625	7.16	181.86	14.00	355.60	9.50	241.30	2.19	55.63	1.88	47.75	8.75	222.25
9.0000	9.03	229.36	16.50	419.10	11.88	301.75	2.50	63.50	2.19	55.63	10.75	273.05
11.0000	11.03	280.16	20.00	508.00	14.00	355.60	2.81	71.37	2.50	63.50	13.50	342.90
13.6250	13.66	346.96	22.00	558.80	16.25	412.75	2.94	74.68	2.62	66.55	15.75	400.05
16.7500	16.78	426.21	27.00	685.80	20.00	508.00	3.31	84.07	3.00	76.20	19.50	495.30
21.2500	21.28	540.51	32.00	812.80	25.00	635.00	3.88	98.55	3.50	88.90	24.00	609.60

Bolt sizes

Nominal size	Diameter of bolt circle BC		Number of bolts	Diameter of bolts		Length of bolts L		Ring number R or RX
	(in)	(mm)		(in)	(mm)	(in)	(mm)	R-RX
2.0625	5.00	127.00	8	0.625	15.88	4.50	114.30	23
2.5625	5.88	149.35	8	0.750	19.05	5.00	127.00	26
3.1250	6.62	168.15	8	0.750	19.05	5.25	133.35	31
4.0625	8.50	215.90	8	0.875	22.23	6.00	152.40	37
7.0625	11.50	292.10	12	1.000	25.40	7.00	177.80	45
9.0000	13.75	349.25	12	1.125	28.58	8.00	203.20	49
11.0000	17.00	431.80	16	1.250	31.75	8.75	222.25	53
13.6250	19.25	488.95	20	1.250	31.75	9.00	228.60	57
16.7500	23.75	603.25	20	1.500	38.10	10.25	260.35	65
21.2500	28.50	723.90	24	1.625	41.28	11.75	298.45	73

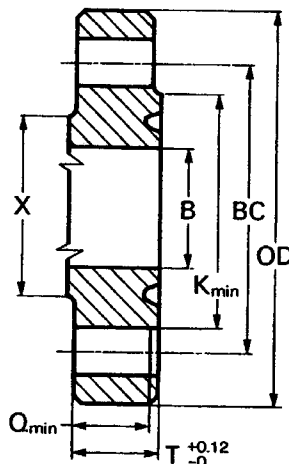

API TYPE 6B FLANGES
Working pressure 3000 psi (20.7 MPa)
(API Spec 6A, 17th edition, February 1, 1996)

Nominal size	Maximum bore B		Outside diameter OD		Diameter of raised face K		Total thickness T		Minimum thickness Q		Diameter of hub X	
	(in)	(mm)	(in)	(mm)	(in)	(mm)	(in)	(mm)	(in)	(mm)	(in)	(mm)
2.0625	2.09	53.09	8.50	215.90	4.88	123.95	1.81	45.97	1.50	38.10	4.12	104.65
2.5625	2.59	65.79	9.62	244.35	5.38	136.65	1.94	49.28	1.62	41.15	4.88	123.95
3.1250	3.22	81.79	9.50	241.30	6.12	155.45	1.81	45.97	1.50	38.10	5.00	127.00
4.0625	4.28	108.71	11.50	292.10	7.12	180.85	2.06	52.32	1.75	44.45	6.25	158.75
7.0625	7.16	181.86	15.00	381.00	9.50	241.30	2.50	63.50	2.19	55.63	9.25	234.95
9.0000	9.03	229.36	18.50	469.90	12.12	307.85	2.81	71.37	2.50	63.50	11.75	298.45
11.0000	11.03	280.16	21.50	546.10	14.25	361.95	3.06	77.72	2.75	69.85	14.50	368.30
13.6250	13.66	346.96	24.00	609.60	16.50	419.10	3.44	87.38	3.12	79.25	16.50	419.10
16.7500	16.78	426.21	27.75	704.85	20.62	523.75	3.94	100.08	3.50	88.90	20.00	508.00
20.7500	20.78	527.81	33.75	857.25	25.50	647.70	4.75	120.65	4.25	107.95	24.50	622.30

Bolt sizes

Nominal size	Diameter of bolt circle BC		Number of bolts	Diameter of bolts		Length of bolts L		Ring number R or RX
	(in)	(mm)		(in)	(mm)	(in)	(mm)	R-RX
2.0625	6.50	165.10	8	0.875	22.23	6.00	152.40	24
2.5625	7.50	190.50	8	1.000	25.40	6.50	165.10	27
3.1250	7.50	190.50	8	0.875	22.23	6.00	152.40	31
4.0625	9.25	234.95	8	1.125	28.58	7.00	177.80	37
7.0625	12.50	317.50	12	1.125	28.58	8.00	203.20	45
9.0000	15.50	393.70	12	1.375	34.93	9.00	228.60	49
11.0000	18.50	469.90	16	1.375	34.93	9.50	241.30	53
13.6250	21.00	533.40	20	1.375	34.93	10.25	260.35	57
16.7500	24.25	615.95	20	1.625	41.28	11.75	298.45	66
20.7500	29.50	749.30	20	2.000	50.80	14.50	368.30	74

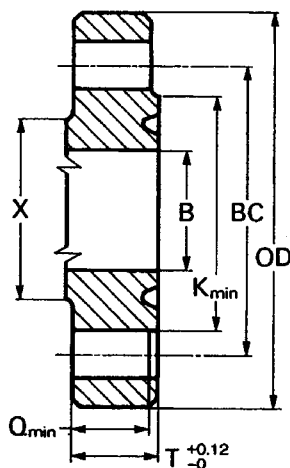

API TYPE 6B FLANGES

Working pressure 5000 psi (34.5 MPa)
(API Spec 6A, 17th edition, February 1, 1996)

Nominal size	Maximum bore B		Outside diameter OD		Diameter of raised face K		Total thickness T		Minimum thickness Q		Diameter of hub X	
	(in)	(in) (mm)	(in)	(mm)	(in)	(mm)	(in)	(mm)	(in)	(mm)	(in)	(mm)
2.0625	2.09	53.09	8.50	215.90	4.88	123.95	1.81	45.97	1.50	38.10	4.12	104.65
2.5625	2.59	65.79	9.62	244.35	5.38	136.65	1.94	49.28	1.62	41.15	4.88	123.95
3.1250	3.22	81.79	10.50	266.70	6.62	168.15	2.19	55.63	1.88	47.75	5.25	133.35
4.0625	4.28	108.71	12.25	311.15	7.62	193.55	2.44	61.98	2.12	53.85	6.38	162.05
7.0625	7.16	181.86	15.50	393.70	9.75	247.65	3.62	91.95	3.25	82.55	9.00	228.60
9.0000	9.03	229.36	19.00	482.60	12.50	317.50	4.06	103.12	3.62	91.95	11.50	292.10
11.0000	11.03	280.16	23.00	584.20	14.63	371.60	4.69	119.13	4.25	107.95	14.50	368.30

Bolt sizes

Nominal size	Diameter of bolt circle BC		Number of bolts	Diameter of bolts		Length of bolts L		Ring number R or RX
	(in)	(in) (mm)		(in)	(mm)	(in)	(mm)	R-RX
2.0625	6.50	165.10	8	0.875	22.23	6.00	152.40	24
2.5625	7.50	190.50	8	1.000	25.40	6.50	165.10	27
3.1250	8.00	203.20	8	1.125	28.58	7.25	184.15	35
4.0625	9.50	241.30	8	1.250	31.75	8.00	203.20	39
7.0625	12.50	317.50	12	1.375	34.93	10.75	273.05	46
9.0000	15.50	393.70	12	1.625	41.28	12.00	304.80	50
11.0000	19.00	482.60	16	1.875	47.63	13.75	349.25	54

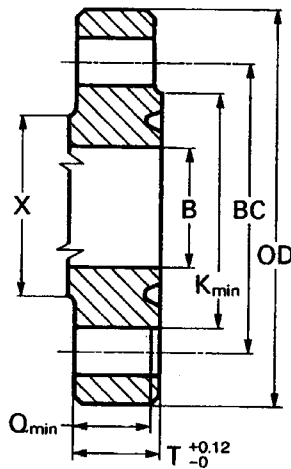

API TYPE 6BX FLANGES
Working pressures: 2000 psi (13.8 MPa), 3000 psi (20.7 MPa),
5000 psi (34.5 MPa) and 10 000 psi (69 MPa)
(API Spec 6A, 17th edition, February 1, 1996)

Nominal size	Maximum bore B		Outside diameter OD		Diameter of raised face K		Total thickness T		Large diameter of hub J1		Small diameter of hub J2	
	(in)	(mm)	(in)	(mm)	(in)	(mm)	(in)	(mm)	(in)	(mm)	(in)	(mm)
2000 psi (13.8 MPa)												
26.7500	26.78	680.21	41.00	1041.40	31.69	804.93	4.97	126.24	32.91	835.91	29.25	742.95
30.00	30.03	762.76	44.19	1122.43	35.75	908.05	5.28	134.11	36.69	931.93	32.80	833.12
3000 psi (20.7 MPa)												
26.7500	26.78	680.21	43.38	1101.85	32.75	831.85	6.34	161.04	34.25	869.95	30.56	776.22
30.00	30.03	762.76	46.68	1185.67	36.31	922.27	6.58	167.13	38.19	970.03	34.30	871.22
5000 psi (34.5 MPa)												
13.6250	13.66	346.96	26.50	673.10	18.00	457.20	4.44	112.78	18.94	481.08	16.69	423.93
16.7500	16.78	426.21	30.38	771.66	21.06	534.92	5.13	130.30	21.88	555.75	20.75	527.05
18.7500	18.78	477.01	35.62	904.75	24.69	627.13	6.53	165.86	26.56	674.62	23.56	598.42
21.2500	21.28	540.51	39.00	990.60	27.62	701.55	7.12	180.85	29.88	758.95	26.75	679.45
10 000 psi (69 MPa)												
1.8125	1.84	46.74	7.38	187.45	4.12	104.65	1.66	42.16	3.50	88.90	2.56	65.02
2.0625	2.09	53.09	7.88	200.15	4.38	111.25	1.73	43.94	3.94	100.08	2.94	74.68
2.5625	2.59	66.79	9.12	231.65	5.19	131.83	2.02	51.31	4.75	120.65	3.62	91.95
3.0625	3.09	78.49	10.62	269.75	6.00	152.40	2.30	58.42	5.59	141.99	4.34	110.24
4.0625	4.09	103.89	12.44	315.98	7.28	184.91	2.77	70.36	7.19	182.63	5.75	146.05
5.1250	5.16	131.06	14.06	357.12	8.69	220.73	3.12	79.25	8.81	223.77	7.19	182.63
7.0625	7.09	180.09	18.88	479.55	11.88	301.75	4.06	103.12	11.88	301.75	10.00	254.00
9.0000	9.03	229.36	21.75	552.45	14.12	358.65	4.88	123.95	14.75	374.65	12.88	327.15
11.0000	11.03	280.16	25.75	654.05	16.88	428.75	5.56	141.22	17.75	450.85	15.75	400.05
13.6250	13.66	346.96	30.25	768.35	20.38	517.65	6.62	168.15	21.75	552.45	19.50	495.30
16.7500	16.78	426.21	34.31	871.47	22.69	576.33	6.62	168.15	25.81	655.57	23.69	601.73
18.7500	18.78	477.01	40.94	1039.88	27.44	696.98	8.78	223.01	29.62	752.35	26.56	674.62
21.2500	21.28	540.51	45.00	1143.00	30.75	781.05	9.50	241.30	33.38	847.85	30.00	762.00

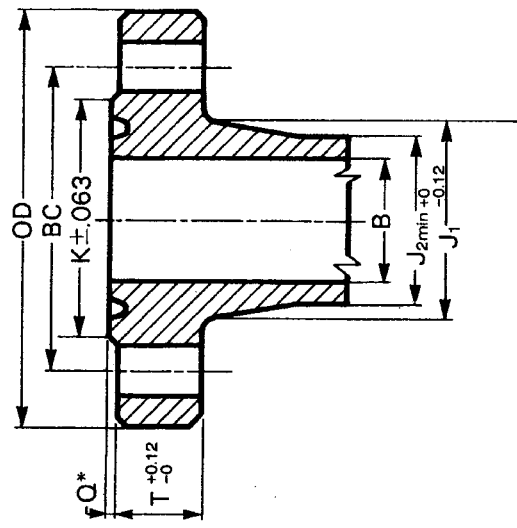

$O_{max} = E$ (Table X D3 - API 6A)
 $O_{min} = 0.12''$

API TYPE 6BX FLANGES

Working pressures: 2000 psi (13.8 MPa), 3000 psi (20.7 MPa),
5000 psi (34.5 MPa) and 10 000 psi (69 MPa)
(API Spec 6A, 17th edition, February 1, 1996)

Bolt sizes

Nominal size (in)	Diameter of bolt circle BC		Number of bolts	Diameter of bolts		Length of bolts L		Ring-point type
	(in)	(mm)		(in)	(mm)	(in)	(mm)	
2000 psi (13.8 MPa)								
26.75	37.50	952.50	20	1.750	44.45	13.75	349.25	167
30.00	40.94	1039.88	32	1.625	41.28	14.25	361.95	303
3000 psi (20.7 MPa)								
26.75	39.38	1000.25	24	2.000	50.80	17.00	431.80	168
30.00	42.94	1090.68	32	1.875	47.63	17.75	450.85	303
5000 psi (34.5 MPa)								
13.6250	23.25	590.55	16	1.625	41.28	12.50	317.50	160
16.7500	26.62	676.15	16	1.875	47.63	14.50	368.30	162
18.7500	31.62	803.15	20	2.000	50.80	17.50	444.50	163
21.2500	34.88	885.95	24	2.000	50.80	18.75	476.25	165
10 000 psi (69 MPa)								
1.8125	5.75	146.05	8	0.750	19.05	5.00	127.00	151
2.0625	6.25	158.75	8	0.750	19.05	5.20	132.08	152
2.5625	7.25	184.15	8	0.875	22.23	6.00	152.40	153
3.0625	8.50	215.90	8	1.000	25.40	6.75	171.45	154
4.0625	10.19	258.83	8	1.125	28.58	8.00	203.20	155
5.1250	11.81	299.97	12	1.125	28.58	8.75	222.25	169
7.0625	15.88	403.35	12	1.500	38.10	11.25	285.75	156
9.0000	18.75	476.25	16	1.500	38.10	13.00	330.20	157
11.0000	22.25	565.15	16	1.750	44.45	15.00	381.00	158
13.6250	26.50	673.10	20	1.875	47.63	17.25	438.15	159
16.7500	30.56	776.22	24	1.875	47.63	17.50	444.50	162
18.7500	36.44	925.58	24	2.250	57.15	22.50	571.50	164
21.2500	40.25	1022.35	24	2.500	63.50	24.50	622.30	166

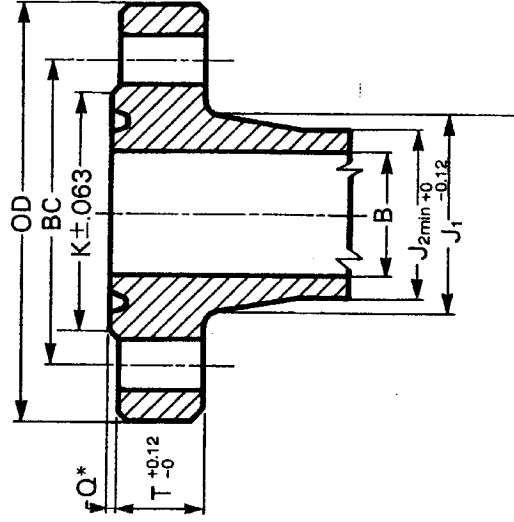

$Q_{max}^* = E$ (Table X D3 - API 6A)
 $Q_{min}^* = 0.12''$

API TYPE 6BX FLANGES

Working pressure: 15 000 psi (103.5 MPa)
(API Spec 6A, 17th edition, February 1, 1996)

Nominal size	Maximum bore B		Outside diameter OD		Diameter of raised face K		Total thickness T		Large diameter of hub J1		Small diameter of hub J2	
	(in)	(mm)	(in)	(mm)	(in)	(mm)	(in)	(mm)	(in)	(mm)	(in)	(mm)
1.8125	1.84	46.74	8.19	208.03	4.19	106.43	1.78	45.21	3.84	97.54	2.81	71.37
2.0625	2.09	53.09	8.75	222.25	4.50	114.30	2.00	50.80	4.38	111.25	3.25	82.55
2.5625	2.59	65.79	10.00	254.00	5.25	133.35	2.25	57.15	5.06	128.52	3.94	100.08
3.0625	3.09	78.49	11.31	287.27	6.06	153.92	2.53	64.26	6.06	153.92	4.81	122.17
4.0625	4.09	103.89	14.19	360.43	7.62	193.55	3.09	78.49	7.69	195.33	6.25	158.75
7.0625	7.09	180.09	19.88	504.95	12.00	304.80	4.69	119.13	12.81	325.37	10.88	276.35
9.0000	9.03	229.36	25.50	647.70	15.00	381.00	5.75	146.05	17.00	431.80	13.75	349.25
11.0000	11.03	280.16	32.00	812.80	17.88	454.15	7.38	187.45	23.00	584.20	16.81	426.97
13.6250	13.66	346.96	34.88	885.95	21.31	541.27	8.06	204.72	23.44	595.38	20.81	528.57
18.7500	18.78	477.01	45.75	1162.05	28.44	722.38	10.06	255.52	32.00	812.80	28.75	730.25

Bolt sizes

Nominal size	Diameter of bolt circle BC		Number of bolts	Diameter of bolts		Length of bolts L		Ring joint type
	(in)	(mm)		(in)	(mm)	(in)	(mm)	BX
1.8125	6.31	160.27	8	0.875	22.23	5.50	139.70	151
2.0625	6.88	174.75	8	0.875	22.23	6.00	152.40	152
2.5625	7.88	200.15	8	1.000	25.40	6.75	171.45	153
3.0625	9.06	230.12	8	1.125	28.58	7.50	190.50	154
4.0625	11.44	290.58	8	1.375	34.93	9.25	234.95	155
7.0625	16.88	428.75	16	1.500	38.10	12.75	323.85	156
9.0000	21.75	552.45	16	1.875	47.63	15.75	400.05	157
11.0000	28.00	711.20	20	2.000	50.80	19.25	488.95	158
13.6250	30.38	771.65	20	2.250	57.15	21.25	539.75	159
18.7500	40.00	1016.00	20	3.000	76.20	26.75	679.45	164

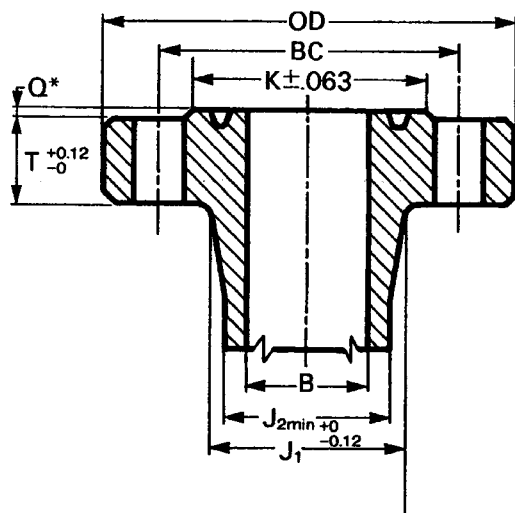

$Q^*_{max} = E$ (Table X D3 – API 6A)

$Q^*_{min} = 0.12''$

API TYPE 6BX FLANGES

Working pressure 20 000 psi (138 MPa)
(API Spec 6A, 17th edition, February 1, 1996)

Nominal size	Maximum bore B		Outside diameter OD		Diameter of raised face K		Total thickness T		Large diameter of hub J1		Small diameter of hub J2	
	(in)	(mm)	(in)	(mm)	(in)	(mm)	(in)	(mm)	(in)	(mm)	(in)	(mm)
1.8125	1.84	46.74	10.12	257.05	4.62	117.35	2.50	63.50	5.25	133.35	4.31	109.47
2.0625	2.09	53.09	11.31	287.27	5.19	131.83	2.81	71.37	6.06	153.92	5.00	127.00
2.5625	2.59	65.79	12.81	325.37	5.94	150.88	3.12	79.25	6.81	172.97	5.69	144.53
3.0625	3.09	78.49	14.06	357.12	6.75	171.45	3.38	85.85	7.56	192.02	6.31	160.27
4.0625	4.09	103.89	17.56	446.02	8.62	218.95	4.19	106.43	9.56	242.82	8.12	206.25
7.0625	7.09	180.09	25.81	655.57	13.88	352.55	6.50	165.10	15.19	385.83	13.31	338.07
9.0000	9.03	229.36	31.69	804.93	17.38	441.45	8.06	204.72	18.94	481.08	16.88	428.75
11.0000	11.03	280.16	34.75	882.65	19.88	504.95	8.81	223.77	22.31	566.67	20.00	508.00
13.6250	13.66	346.96	45.75	1162.05	24.19	614.43	11.50	292.10	27.31	693.67	24.75	628.65

Bolt sizes

Nominal size	Diameter of bolt circle BC		Number of bolts	Diameter of bolts		Length of bolts L		Ring joint type
	(in)	(mm)		(in)	(mm)	(in)	(mm)	B
1.8125	8.00	203.20	8	1.0000	25.40	7.50	190.50	151
2.0625	9.06	230.12	8	1.1250	28.58	8.25	209.55	152
2.5625	10.31	261.87	8	1.2500	31.75	9.25	234.95	153
3.0625	11.31	287.27	8	1.3750	34.93	10.00	254.00	154
4.0625	14.06	357.12	8	1.7500	44.45	12.25	311.15	155
7.0625	21.81	553.97	16	2.0000	50.80	17.50	444.50	156
9.0000	27.00	685.80	16	2.5000	63.50	22.38	568.45	157
11.0000	29.50	749.30	16	2.7500	69.85	23.75	603.25	158
13.6250	40.00	1016.00	20	3.1250	79.38	30.00	762.00	159

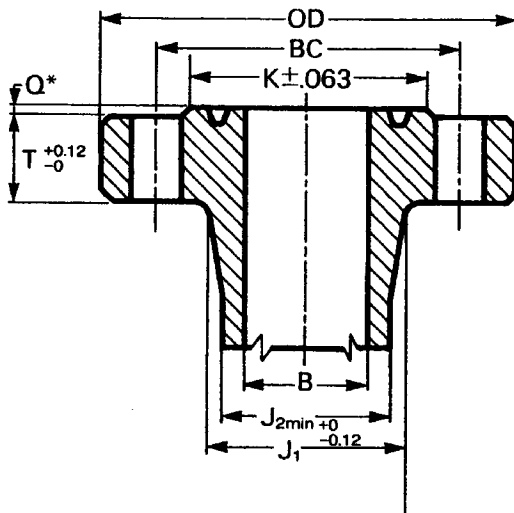

$$Q_{max}^* = E \text{ (Table X D3 - API 6A)}$$

$$Q_{min}^* = 0.12''$$

API TYPE R RING-JOINT GASKETS (API Spec 6A, 17th edition, February 1, 1996)

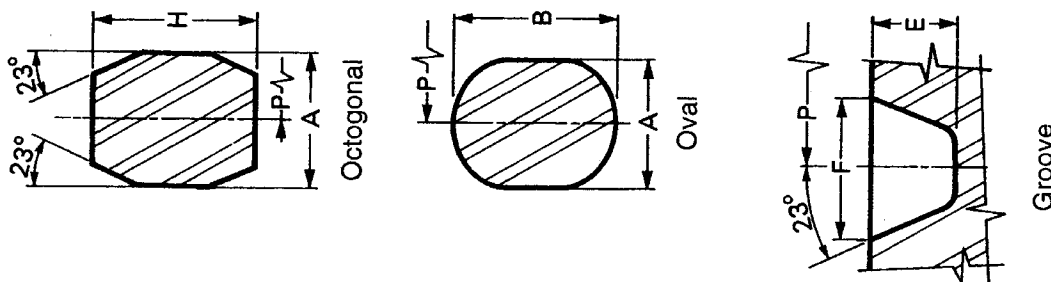

Ring No.	Pitch diameter of ring and groove P		Width of ring A		Height of oval ring B		Height of octagonal ring H		Depth of groove E		Width of groove F		Approximate distance between make-up flanges S	
	(in)	(mm)	(in)	(mm)	(in)	(mm)	(in)	(mm)	(in)	(mm)	(in)	(mm)	(in)	(mm)
20	2.688	68.28	0.313	7.95	0.56	14.22	0.50	12.70	0.25	6.35	0.344	8.74	0.16	4.06
23	3.250	82.55	0.438	11.13	0.69	17.53	0.63	16.00	0.31	7.87	0.469	11.91	0.19	4.83
24	3.750	95.25	0.438	11.13	0.69	17.53	0.63	16.00	0.31	7.87	0.469	11.91	0.19	4.83
26	4.000	101.60	0.438	11.13	0.69	17.53	0.63	16.00	0.31	7.87	0.469	11.91	0.19	4.83
27	4.250	107.95	0.438	11.13	0.69	17.53	0.63	16.00	0.31	7.87	0.469	11.91	0.19	4.83
31	4.875	123.83	0.438	11.13	0.69	17.53	0.63	16.00	0.31	7.87	0.469	11.91	0.19	4.83
35	5.375	136.53	0.438	11.13	0.69	17.53	0.63	16.00	0.31	7.87	0.469	11.91	0.19	4.83
37	5.875	149.23	0.438	11.13	0.59	14.99	0.63	16.00	0.31	7.87	0.469	11.91	0.19	4.83
39	6.375	161.93	0.438	11.13	0.69	17.53	0.63	16.00	0.31	7.87	0.469	11.91	0.19	4.83
41	7.125	180.98	0.438	11.13	0.69	17.53	0.63	16.00	0.31	7.87	0.469	11.91	0.19	4.83
44	7.625	193.68	0.438	11.13	0.69	17.53	0.63	16.00	0.31	7.87	0.469	11.91	0.19	4.83
45	8.313	211.15	0.438	11.13	0.69	17.53	0.63	16.00	0.31	7.87	0.469	11.91	0.19	4.83
46	8.313	211.15	0.500	12.70	0.75	19.05	0.69	17.53	0.38	9.65	0.521	13.23	0.13	3.30
47	9.000	228.60	0.750	19.05	1.00	25.40	0.94	23.88	0.50	12.70	0.781	19.84	0.16	4.06
49	10.625	269.88	0.438	11.13	0.69	17.53	0.63	16.00	0.31	7.87	0.469	11.91	0.19	4.83
50	10.625	269.88	0.625	15.88	0.88	22.35	0.81	20.57	0.44	11.18	0.656	16.66	0.16	4.06
53	12.750	323.85	0.438	11.13	0.69	17.53	0.63	16.00	0.31	7.87	0.469	11.91	0.19	4.83
54	12.750	323.85	0.625	15.88	0.88	22.35	0.81	20.57	0.44	11.18	0.656	16.66	0.16	4.06
57	15.000	381.00	0.438	11.13	0.69	17.53	0.63	16.00	0.31	7.87	0.469	11.91	0.19	4.83
63	16.500	419.10	1.000	25.40	1.31	33.27	1.25	31.75	0.62	15.75	1.063	27.00	0.22	5.59
65	18.500	469.90	0.438	11.13	0.69	17.53	0.63	16.00	0.31	7.87	0.469	11.91	0.19	4.83
66	18.500	469.90	0.625	15.88	0.88	22.35	0.81	20.57	0.44	11.18	0.656	16.66	0.16	4.06
69	21.000	533.40	0.438	11.13	0.69	17.53	0.63	16.00	0.31	7.87	0.469	11.91	0.19	4.83
70	21.000	533.40	0.750	19.05	1.00	25.40	0.94	23.88	0.50	12.70	0.781	19.84	0.19	4.83
73	23.000	584.20	0.500	12.70	0.75	19.05	0.69	17.53	0.38	9.65	0.531	13.49	0.13	3.30
74	23.000	584.20	0.750	19.05	1.00	25.40	0.94	23.88	0.50	12.70	0.781	19.84	0.19	4.83
82	2.250	57.15	0.438	11.13	0.63	16.00	0.63	16.00	0.31	7.87	0.469	11.91	0.19	4.83
84	2.500	63.50	0.438	11.13	0.63	16.00	0.63	16.00	0.31	7.87	0.469	11.91	0.19	4.83
85	3.125	79.38	0.500	12.70	0.69	17.53	0.69	17.53	0.38	9.65	0.531	13.49	0.13	3.30
86	3.563	90.50	0.625	15.88	0.81	20.57	0.81	20.57	0.44	11.18	0.656	16.66	0.16	4.06
87	3.938	100.03	0.625	15.88	0.81	20.57	0.81	20.57	0.44	11.18	0.656	16.66	0.16	4.06
88	4.875	123.83	0.750	19.05	0.94	23.88	0.94	23.88	0.50	12.70	0.781	19.84	0.19	4.83
89	4.500	114.30	0.750	19.05	0.94	23.88	0.94	23.88	0.50	12.70	0.781	19.84	0.19	4.83
90	6.125	155.58	0.875	22.23	1.06	26.92	1.06	26.92	0.56	14.22	0.906	23.01	0.19	4.83
91	10.250	260.35	1.250	31.75	1.50	38.10	1.50	38.10	0.69	17.53	1.313	33.35	0.16	4.06
99	9.250	234.95	0.438	11.13	0.63	16.00	0.63	16.00	0.31	7.87	0.469	11.91	0.19	4.83

API TYPE RX RING-JOINT GASKETS
(API Spec 6A, 17th edition, February 1, 1996)

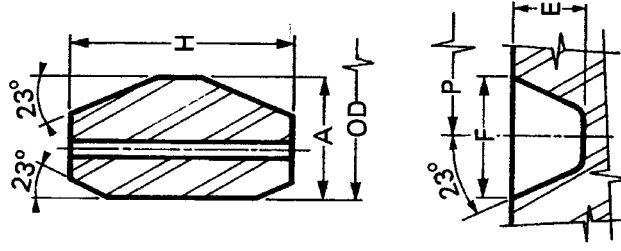

Ring No.	Pitch diameter of ring and groove P		Outside diameter of ring OD		Width of ring A		Height H		Depth of groove E		Width of groove F		Approximate distance between make-up flanges S	
	(in)	(mm)	(in)	(mm)	(in)	(mm)	(in)	(mm)	(in)	(mm)	(in)	(mm)	(in)	(mm)
RX														
20	2.688	68.28	3.000	76.20	0.344	8.74	0.750	19.05	0.25	6.35	0.344	8.74	0.38	9.65
23	3.250	82.55	3.672	93.27	0.469	11.91	1.000	25.40	0.31	7.87	0.469	11.91	0.47	11.94
24	3.750	95.25	4.172	105.97	0.469	11.91	1.000	25.40	0.31	7.87	0.469	11.91	0.47	11.94
25	4.000	101.60	4.313	109.55	0.344	8.74	0.750	19.05	0.25	6.35	0.344	8.74	0.47	11.94
26	4.000	101.60	4.406	111.91	0.469	11.91	1.000	25.40	0.31	7.87	0.469	11.91	0.47	11.94
27	4.250	107.95	4.656	118.26	0.469	11.91	1.000	25.40	0.31	7.87	0.469	11.91	0.47	11.94
31	4.875	123.83	5.297	134.54	0.469	11.91	1.000	25.40	0.31	7.87	0.469	11.91	0.47	11.94
35	5.375	136.53	5.797	147.24	0.469	11.91	1.000	25.40	0.31	7.87	0.469	11.91	0.47	11.94
37	5.875	149.23	6.297	159.94	0.469	11.91	1.000	25.40	0.31	7.87	0.469	11.91	0.47	11.94
39	6.375	161.93	6.797	172.64	0.469	11.91	1.000	25.40	0.31	7.87	0.469	11.91	0.47	11.94
41	7.125	180.98	7.547	191.69	0.469	11.91	1.000	25.40	0.31	7.87	0.469	11.91	0.47	11.94
44	7.625	193.68	8.047	204.39	0.469	11.91	1.000	25.40	0.31	7.87	0.469	11.91	0.47	11.94
45	8.313	211.15	8.734	221.84	0.469	11.91	1.000	25.40	0.31	7.87	0.469	11.91	0.47	11.94
46	8.313	211.15	8.750	222.25	0.531	13.49	1.125	28.58	0.38	9.65	0.531	13.49	0.47	11.94
47	9.000	228.60	9.656	245.26	0.781	19.84	1.625	41.28	0.50	12.70	0.781	19.84	0.91	23.11
49	10.625	269.88	11.047	280.59	0.656	16.66	1.250	31.75	0.44	11.18	0.656	16.66	0.47	11.94
50	10.625	269.88	11.156	283.36	0.656	16.66	1.250	31.75	0.44	11.18	0.656	16.66	0.47	11.94
53	12.750	323.85	13.172	334.57	0.469	11.91	1.000	25.40	0.31	7.87	0.469	11.91	0.47	11.94
54	12.750	323.85	13.281	337.34	0.656	16.66	1.250	31.75	0.44	11.18	0.656	16.66	0.47	11.94
57	15.000	381.00	15.422	391.72	0.469	11.91	1.000	25.40	0.31	7.87	0.469	11.91	0.47	11.94
63	16.500	419.10	17.391	441.73	1.063	27.00	2.000	50.80	0.63	16.00	1.063	27.00	0.84	21.34
65	18.500	469.90	18.922	480.62	0.469	11.91	1.000	25.40	0.31	7.87	0.469	11.91	0.47	11.94
66	18.500	469.90	19.031	483.39	0.656	16.66	1.250	31.75	0.44	11.18	0.656	16.66	0.47	11.94
69	21.000	533.40	21.422	544.12	0.469	11.91	1.000	25.40	0.31	7.87	0.469	11.91	0.47	11.94
70	21.000	533.40	21.656	550.06	0.781	19.84	1.625	41.28	0.50	12.70	0.781	19.84	0.72	18.29
73	23.000	584.20	23.469	596.11	0.531	13.49	1.250	31.75	0.38	9.65	0.531	13.49	0.59	14.99
74	23.000	584.20	23.656	600.86	0.781	19.84	1.625	41.28	0.50	12.70	0.781	19.84	0.72	18.29
82	2.250	57.15	2.672	67.87	0.469	11.91	1.000	25.40	0.31	7.87	0.469	11.91	0.47	11.94
84	2.500	63.50	2.922	74.22	0.469	11.91	1.000	25.40	0.31	7.87	0.469	11.91	0.47	11.94
85	3.125	79.38	3.547	90.09	0.531	13.49	1.000	25.40	0.38	9.65	0.531	13.49	0.38	9.65
86	3.563	90.50	4.078	103.58	0.594	15.09	1.125	28.58	0.44	11.18	0.594	15.09	0.38	9.65
87	3.938	100.03	4.453	113.11	0.594	15.09	1.125	28.58	0.44	11.18	0.594	15.09	0.38	9.65
88	4.875	123.83	5.484	139.29	0.688	17.48	1.250	31.75	0.50	12.70	0.688	17.48	0.38	9.65
89	4.500	114.30	5.109	129.77	0.719	18.26	1.250	31.75	0.50	12.70	0.719	18.26	0.38	9.65
90	6.125	155.58	6.875	174.63	0.781	19.84	1.750	44.45	0.56	14.22	0.781	19.84	0.38	9.65
91	10.250	260.35	11.297	286.94	1.388	35.26	1.781	45.24	0.69	17.53	1.388	35.26	0.72	18.29
99	9.250	234.95	9.672	245.67	0.469	11.91	1.000	25.40	0.31	7.87	0.469	11.91	0.75	19.05
201	1.813	46.05	2.026	51.46	0.226	5.74	0.445	11.30	0.16	4.06	0.226	5.74	0.47	11.94
205	2.250	57.15	2.453	62.31	0.219	5.56	0.437	11.10	0.16	4.06	0.219	5.56	0.47	11.94
210	3.500	88.90	3.844	97.64	0.375	9.53	0.750	19.05	0.25	6.35	0.375	9.53	0.47	11.94
215	5.125	130.18	5.547	140.89	0.469	11.91	1.000	25.40	0.31	7.87	0.469	11.91	0.47	11.94

API TYPE BX RING-JOINT GASKETS (API Spec 6A, 17th edition, February 1, 1996)

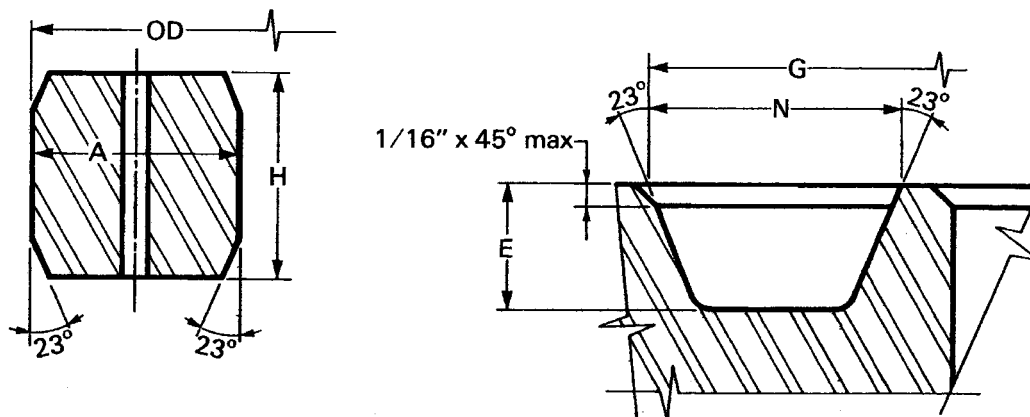

Ring No.	Outside diameter of ring OD		Height H		Width of ring A		Depth of groove E		Outside diameter of groove G		Width of groove N	
	(in)	(mm)	(in)	(mm)	(in)	(mm)	(in)	(mm)	(in)	(mm)	(in)	(mm)
BX												
150	2.842	72.19	0.366	9.30	0.366	9.30	0.220	5.59	2.893	73.48	0.450	11.43
151	3.008	76.40	0.379	9.63	0.379	9.63	0.220	5.59	3.062	77.77	0.466	11.84
152	3.334	84.68	0.403	10.24	0.403	10.24	0.230	5.84	3.395	86.23	0.498	12.65
153	3.974	100.94	0.448	11.38	0.448	11.38	0.270	6.86	4.046	102.77	0.554	14.07
154	4.600	116.84	0.488	12.40	0.488	12.40	0.300	7.62	4.685	119.00	0.606	15.39
155	5.825	147.96	0.560	14.22	0.560	14.22	0.330	8.38	5.930	150.62	0.698	17.73
156	9.367	237.92	0.733	18.62	0.733	18.62	0.440	11.18	9.521	241.83	0.921	23.39
157	11.593	294.46	0.826	20.98	0.826	20.98	0.500	12.70	11.774	299.06	1.039	26.39
158	13.860	352.04	0.911	23.14	0.911	23.14	0.560	14.22	14.064	357.23	1.149	29.18
159	16.800	426.72	1.012	25.70	1.012	25.70	0.620	15.75	17.033	432.64	1.279	32.49
160	15.850	402.59	0.938	23.83	0.541	13.74	0.560	14.22	16.063	408.00	0.786	19.96
161	19.347	491.41	1.105	28.07	0.638	16.21	0.670	17.02	19.604	497.94	0.930	23.62
162	18.720	475.49	0.560	14.22	0.560	14.22	0.330	8.38	18.832	478.33	0.705	17.91
163	21.896	556.16	1.185	30.10	0.684	17.37	0.720	18.29	22.185	563.50	1.006	25.55
164	22.463	570.56	1.185	30.10	0.968	24.59	0.720	18.29	22.752	577.90	1.290	32.77
165	24.595	624.71	1.261	32.03	0.728	18.49	0.750	19.05	24.904	632.56	1.071	27.20
166	25.198	640.03	1.261	32.03	1.029	26.14	0.750	19.05	25.507	647.88	1.373	34.87
167	29.896	759.36	1.412	35.86	0.516	13.11	0.840	21.34	30.249	768.32	0.902	22.91
168	30.198	767.03	1.412	35.86	0.632	16.05	0.840	21.34	30.481	774.22	1.018	25.86
169	6.831	173.51	0.624	15.85	0.509	12.93	0.380	9.65	6.955	176.66	0.666	16.92
170	8.584	218.03	0.560	14.22	0.560	14.22	0.330	8.38	8.696	220.88	0.705	17.91
171	10.529	267.44	0.560	14.22	0.560	14.22	0.330	8.38	10.641	270.28	0.705	17.91
172	13.113	333.07	0.560	14.22	0.560	14.22	0.330	8.38	13.225	335.92	0.705	17.91
303	33.573	852.75	1.494	37.95	0.668	16.97	0.890	22.61	33.949	862.30	1.078	27.38

RECOMMENDED FLANGE BOLT TORQUE

Bolt and size (in)	40 000 psi stress (276 MPa)				52 500 psi stress (362 MPa)			
	Bolt tension		Make-up torque		Bolt tension		Make-up torque	
	(lbf)	(daN)	(ft.lb)	(daN.m)	(lbf)	(daN)	(ft.lb)	(daN.m)
1/2 — 13 UNC	5 674	2 524	45	6	7 448	3 313	59	8
5/8 — 11 UNC	9 026	4 015	86	12	11 846	5 269	113	15
3/4 — 10 UNC	13 355	5 941	150	20	17 528	7 797	196	27
7/8 — 9 UNC	18 482	8 221	239	32	24 257	10 790	313	42
1 — 8 UN	24 229	10 778	361	49	31 800	14 145	474	64
1 1/8 — 8 UN	31 617	14 064	522	71	41 497	18 459	686	93
1 1/4 — 8 UN	39 987	17 787	726	98	52 483	23 346	953	129
1 3/8 — 8 UN	49 339	21 947	976	132	64 757	28 805	1 281	174
1 1/2 — 8 UN	59 672	26 543	1 277	173	78 320	34 838	1 676	227
1 5/8 — 8 UN	70 988	31 577	1 635	222	93 171	41 445	2 146	291
1 3/4 — 8 UN	83 284	37 047	2 054	279	109 311	48 624	2 695	365
1 7/8 — 8 UN	96 563	42 953	2 538	344	126 739	56 376	3 331	452
2 — 8 UN	110 824	49 297	3 093	419	145 456	64 702	4 060	551
2 1/4 — 8 UN	142 290	63 294	4 435	601	186 755	83 073	5 821	789
2 1/2 — 8 UN	177 683	79 037	6 116	829	233 209	103 736	8 028	1 089
2 5/8 — 8 UN	196 852	87 564	7 097	962	258 368	114 928	9 314	1 263
2 3/4 — 8 UN	217 003	96 528	8 176	1 109	284 817	126 693	10 731	1 455
3 — 8 UN	260 250	115 765	10 653	1 445	341 578	151 941	13 982	1 896
3 1/4 — 8 UN	307 424	136 749	13 585	1 842	403 495	179 483	17 830	2 418
3 3/4 — 8 UN	413 554	183 958	20 967	2 843	542 790	241 445	27 519	3 732
3 7/8 — 8 UN	442 541	196 852	23 157	3 140	580 834	258 368	30 393	4 121
4 — 8 UN	472 509	210 182	25 494	3 457	620 168	275 864	33 461	4 537
4 1/2 — 8 UN	602 200	267 872	36 412	4 937	790 388	351 582	47 790	6 480
4 3/4 — 8 UN	672 936	299 337	42 879	5 814	883 229	392 880	56 289	7 633

API TYPE 16B INTEGRAL HUB CONNECTIONS (API Spec 16A, 1st edition, November 1, 1986)

Nominal size B	Outside diameter OD		Total thickness T		Large diameter of neck J		Groove OD G		Width of groove N		Depth of groove E		Ring gasket number	Cameron clamp number
	(in)	(mm)	(in)	(mm)	(in)	(mm)	(in)	(mm)	(in)	(mm)	(in)	(mm)		
2000 psi. Maximum working pressure = 13.8 MPa														
7 1/16	10.375	263.525	1.443	36.6522	8.875	225.425	8.987	228.2698	0.668	16.9672	0.562	14.275	RX-45	25
16 3/4	20.375	517.525	1.269	32.2326	19	482.6	19.14	486.0290	0.668	16.9672	0.562	14.275	RX-65	12
21 1/4	26.375	669.925	1.872	47.5488	24.5	622.3	23.75	603.3262	0.784	19.9136	0.688	17.475	RX-73	18
3000 psi. Maximum working pressure = 20.7 MPa														
11	15.625	396.875	1.399	35.5346	14	355.6	13.41	340.487	0.668	16.9672	0.562	14.275	RX-53	9
13 5/8	18.375	466.725	1.336	33.9344	16.75	425.45	15.64	397.129	0.668	16.9672	0.562	14.275	RX-57	11
16 3/4	21.250	539.750	1.459	37.0586	19.625	498.475	19.14	486.029	0.668	16.9672	0.562	14.275	RX-65	14

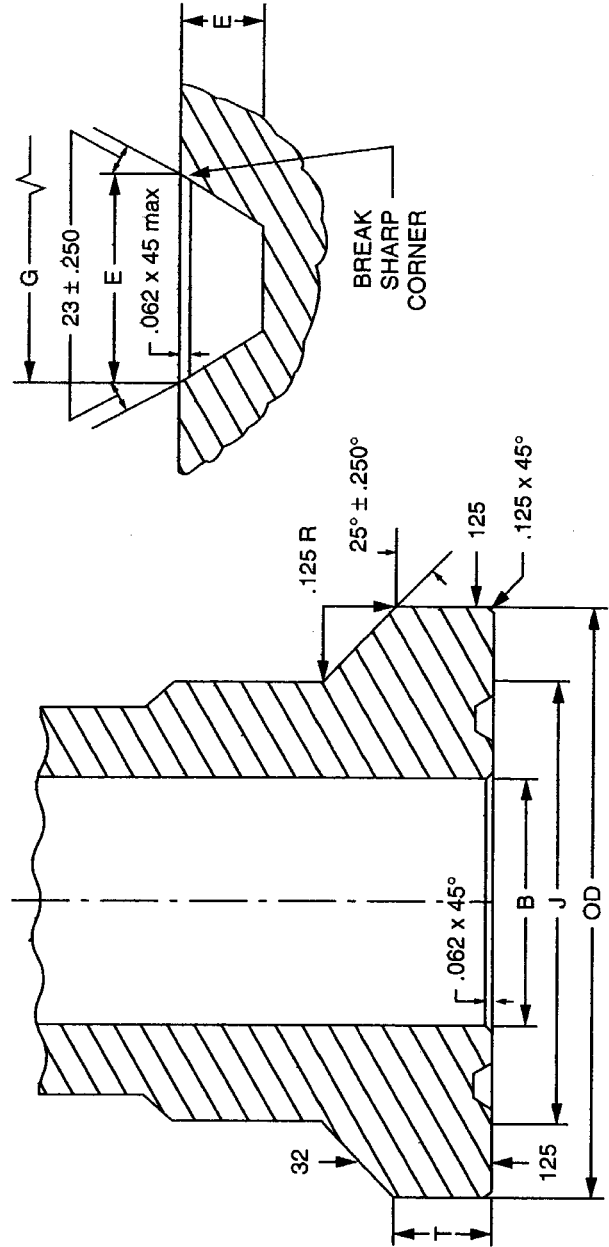

API TYPE 16B INTEGRAL HUB CONNECTIONS (continued)
(API Spec 16A, 1st edition, November 1, 1986)

Nominal size B	Outside diameter OD		Total thickness T		Large diameter of neck J		Groove OD G		Width of groove N		Depth of groove E		Ring gasket number	Cameron clamp number
	(in)	(mm)	(in)	(mm)	(in)	(mm)	(in)	(mm)	(in)	(mm)	(in)	(mm)		
5000 psi. Maximum working pressure = 34.5 MPa														
2 1/16	52.3875	127.7874	1.166	29.616	3.656	92.8624	3.395	86.233	0.498	12.6492	0.234	5.9436	BX-152	1
2 9/16	65.0875	146.8374	1.166	29.616	4.406	111.9124	4.046	102.768	0.554	14.0716	0.226	5.7404	BX-153	2
3 1/8	79.375	160.3248	1.166	29.616	4.938	125.4252	4.685	118.999	0.606	15.3924	0.297	7.5438	BX-154	4
4 1/16	103.188	193.6750	1.197	30.404	6.250	158.7500	5.930	150.622	0.698	17.7292	0.328	8.3312	BX-155	5
7 1/16	179.390	336.5500	1.622	41.199	11.625	295.2750	9.521	241.833	0.921	23.3934	0.438	11.1252	BX-156	8
9	228.600	336.5500	1.622	41.199	11.625	295.2750	11.774	299.06	1.039	26.3906	0.5	12.7000	BX-157	8
11	279.400	412.7500	1.654	42.012	14.625	371.4750	14.064	357.226	1.149	29.1846	0.562	14.2748	BX-158	10
13 5/8	346.075	523.8750	1.871	47.523	19.000	482.6000	16.063	408	0.786	19.9644	0.562	14.2748	BX-160	13
16 3/4	425.450	650.8750	1.778	45.161	24.000	609.6000	18.832	478.333	0.705	17.907	0.328	8.3312	BX-162	19
21 1/4	539.750	793.7500	3.63	92.202	27.875	708.0250	24.904	632.562	1.071	27.2034	0.75	19.0500	BX-165	27
10 000 psi. Maximum working pressure = 69 MPa														
1 13/16	46.0375	127.7874	1.166	29.616	3.656	92.8624	3.062	77.7748	0.466	11.8364	0.219	5.5626	BX-151	1
2 1/16	52.3875	146.8374	1.166	29.616	4.406	111.9124	3.395	86.2330	0.498	12.6492	0.234	5.9436	BX-152	2
2 9/16	65.0875	160.3248	1.166	29.616	4.938	125.4252	4.046	102.7680	0.554	14.0716	0.266	6.7564	BX-153	4
3 1/16	77.7875	193.6750	1.197	30.404	6.250	158.7500	4.685	118.9990	0.606	15.3924	0.297	7.5438	BX-154	5
4 1/16	103.188	214.2998	1.31	33.274	6.812	173.0248	5.930	150.6220	0.698	17.7292	0.328	8.3312	BX-155	6
7 1/16	179.388	412.7500	1.653	41.986	14.625	371.4750	9.521	241.8330	0.921	23.3934	0.438	11.1252	BX-156	10
9	228.600	412.7500	1.653	41.986	14.625	371.4750	11.774	299.0600	1.039	26.3906	0.5	12.7000	BX-157	10
11	279.400	523.8750	2.035	51.689	18.625	473.0750	14.064	357.2260	1.149	29.1846	0.562	14.2748	BX-158	22
13 5/8	346.075	565.1500	2.309	58.649	20.625	523.8750	17.033	432.6380	1.279	32.4866	0.625	15.8750	BX-159	15
16 3/4	425.450	711.2000	3.005	76.327	25.000	635.0000	18.832	478.3330	0.705	17.907	0.328	8.3312	BX-162	28
18 3/4	476.250	793.7500	3.63	92.202	27.875	708.0250	22.752	577.9010	1.29	32.766	0.719	18.2626	BX-164	27
21 1/4	539.750	863.6000	4.005	101.730	30.500	774.7000	25.507	647.8780	1.373	34.8742	0.75	19.0500	BX-166	26

API TYPE 16B INTEGRAL HUB CONNECTIONS (continued)
(API Spec 16A, 1st edition, November 1, 1986)

Nominal size B		Outside diameter OD		Total thickness T		Large diameter of neck J		Groove OD G		Width of groove N		Depth of groove E		Ring gasket number	Cameron clamp number
(in)	(mm)	(in)	(mm)	(in)	(mm)	(in)	(mm)	(in)	(mm)	(in)	(mm)	(in)	(mm)		
15 000 psi. Maximum working pressure = 103.5 MPa															
1 13/16	46.0375	5.781	146.8374	1.166	29.616	4.406	111.9124	3.062	77.7748	0.466	11.8364	0.219	5.5626	BX-151	2
2 1/16	52.3875	6.125	155.5750	1.622	41.199	4.500	114.3000	3.395	86.2330	0.498	12.6492	0.234	5.9436	BX-152	3
2 9/16	65.0875	6.125	155.5750	1.622	41.199	4.500	114.3000	4.046	102.7680	0.554	14.0716	0.266	6.7564	BX-153	3
3 1/16	77.7875	8.437	214.2998	1.31	33.274	6.812	173.0248	4.685	118.9990	0.606	15.3924	0.297	7.5438	BX-154	6
4 1/16	103.1880	13.250	336.5500	1.622	41.199	11.625	295.2750	5.930	150.6220	0.698	17.7292	0.328	8.3312	BX-155	8
7 1/16	179.3900	20.626	523.9004	2.035	51.689	18.625	473.0750	9.521	241.8330	0.921	23.3934	0.438	11.1252	BX-156	22
11	279.4000	22.250	565.1500	2.309	58.649	20.625	523.8750	14.064	357.2260	1.149	29.1846	0.562	14.2748	BX-158	15
13 5/8	346.0750	28.000	711.2000	3.005	76.327	25.000	635.0000	17.033	432.6380	1.279	32.4866	0.625	15.8750	BX-159	28
18 3/4	476.2500	34.000	863.6000	4.005	101.730	30.500	774.7000	22.752	577.9010	1.290	32.7660	0.719	18.2626	BX-164	26
20 000 psi. Maximum working pressure = 138 MPa															
1 13/16	46.0375	5.031	127.7874	1.622	41.199	4.500	114.3000	3.062	77.7748	0.466	11.8364	0.219	5.5626	BX-151	3
2 1/16	52.3875	5.781	146.8374	1.622	41.199	4.500	114.3000	3.395	86.2330	0.498	12.6492	0.234	5.9436	BX-152	3
2 9/16	65.0875	6.312	160.3248	1.31	33.274	6.812	173.0248	4.046	102.7680	0.554	14.0716	0.226	5.7404	BX-153	6
3 1/16	77.7875	7.625	193.6750	1.622	41.199	11.625	295.2750	4.685	118.9990	0.606	15.3924	0.297	7.5438	BX-154	8
4 1/16	103.1880	8.437	214.2998	1.653	41.986	14.625	371.4750	5.930	150.6220	0.698	17.7292	0.328	8.3312	BX-155	10
7 1/16	179.3880	16.250	412.7500	2.309	58.649	20.625	523.8750	9.521	241.8330	0.921	23.3934	0.438	11.1252	BX-156	15
11	279.4000	20.625	523.8750	3.005	76.327	25.000	635.0000	14.064	357.2260	1.149	29.1846	0.562	14.2748	BX-158	

CLAMP FOR FLANGES

Clamp dimensions (cameron)

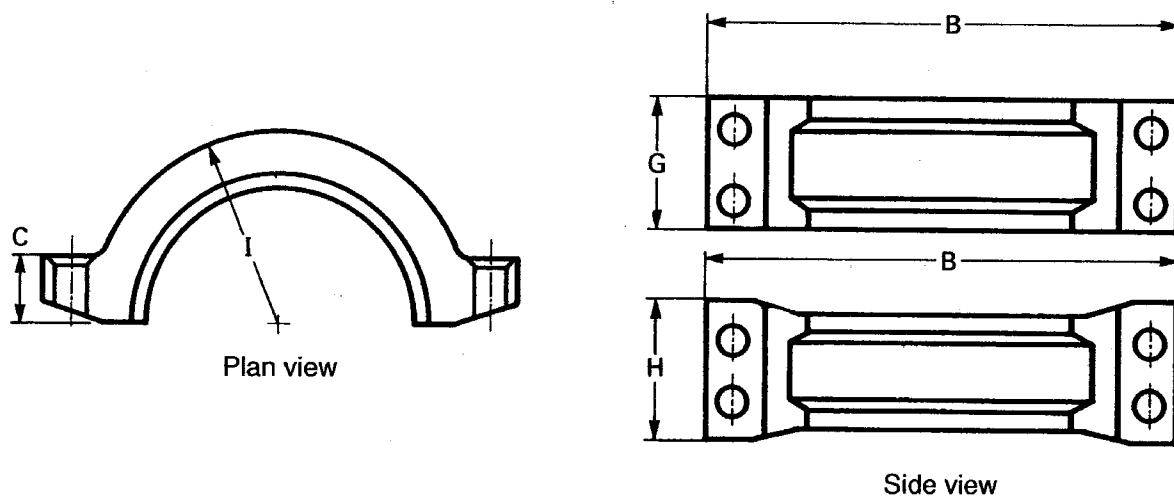

Clamp No.	B (mm)	C (mm)	Nominal size of studs (in)	Length of studs F (mm)	G (mm)	H (mm)	I (mm)
1	266.70	50.80	0.875-9 UN	177.80	106.43	-	97.54
2	304.80	63.50	0.875-9 UN	203.20	108.71	-	108.71
3	355.60	69.85	1.000-8 UN	228.60	157.23	-	127.76
4	317.50	63.50	1.000-8 UN	215.90	113.54	-	119.13
5	349.25	63.50	1.000-8 UN	215.90	114.30	-	134.11
6	419.10	76.20	1.125-8 UN	247.69	136.65	-	153.92
7	508.00	95.25	1.375-8 UN	304.80	149.35	-	187.45
8	603.25	107.95	1.500-8 UN	342.90	165.10	-	223.01
9	654.05	107.95	1.375-8 UN	330.20	139.70	146.05	245.36
10	723.90	139.70	1.625-8 UN	412.75	171.45	-	264.41
11	771.65	141.22	1.375-8 UN	381.00	139.70	149.39	292.10
12	771.65	133.35	1.375-8 UN	381.00	117.35	146.05	305.56
13	838.20	153.16	2.250-8 UN	508.00	195.07	234.95	331.22
14	793.75	165.10	1.625-8 UN	463.55	146.05	146.05	328.68
15	990.60	133.35	2.500-8 UN	488.95	263.65	-	371.35
16	889.00	171.45	1.625-8 UN	476.25	139.70	172.97	373.13
17	968.25	162.05	2.250-8 UN	501.65	172.97	234.95	393.70
18	990.60	165.10	2.250-8 UN	508.00	184.15	241.3	412.75
19	1028.70	200.15	2.500-8 UN	596.90	225.30	266.7	406.40
20	1216.20	152.40	1.500-8 UN	431.80	193.55	-	505.71
21	1025.70	139.70	1.250-8 UN	381.00	165.10	-	421.39
22	853.95	139.70	2.250-8 UN	457.20	222.25	234.95	338.07
23	1397.00	184.15	2.250-8 UN	546.10	234.95	-	607.31
24	1295.40	162.05	1.625-8 UN	457.20	193.55	-	546.10
25	425.45	66.55	0.875-9 UN	215.90	120.65	-	169.93
26	1384.30	290.58	4.000-8 UN	939.80	401.57	-	552.20
27	1231.90	169.67	3.250-8 UN	622.30	333.25	-	496.82
28	1136.90	152.40	3.000-8 UN	660.40	304.80	-	450.85

mm x 0.0394 = in

CIW CLAMP FOR FLANGES

Make-up torque on bolts of CIW clamps

Clamp No.	Nominal size of studs		Torque API 5A lubricant		Torque molybdenum lubricant	
	(in)	(mm)	(daN.m)	(lb.ft)	(daN.m)	(lb.ft)
1	7/8	22.23	18.6	137.27	12.7	93.73
2	7/8	22.23	37.2	274.54	24.5	180.81
3	1	25.40	54.9	405.16	37.2	274.54
4	1	25.40	54.9	405.16	37.2	274.54
5	1	25.40	54.9	405.16	37.2	274.54
6	1 1/8	28.58	81.4	600.73	54.9	405.16
7	1 3/8	34.93	149.0	1 099.62	95.0	701.10
8	1 1/2	38.10	197.0	1 453.86	129.4	954.97
9	1 3/8	34.93	149.0	1 099.62	95.0	701.10
10	1 5/8	41.28	251.0	1 852.38	162.8	1 201.46
11	1 3/8	34.93	149.0	1 099.62	95.0	701.10
12	1 3/8	34.93	149.0	1 099.62	95.0	701.10
13	2 1/4	57.15	678.8	5 009.54	434.5	3 206.61
14	1 5/8	41.28	251.0	1 852.38	162.8	1 201.46
15	2 1/2	63.50	949.6	7 008.05	597.4	4 408.81
16	1 5/8	41.28	251.0	1 852.38	162.8	1 201.46
17	2 1/4	57.15	678.8	5 009.54	434.5	3 206.61
18	2 1/4	57.15	678.8	5 009.54	434.5	3 206.61
19	2 1/2	63.50	949.6	7 008.05	597.4	4 408.81
20	1 1/2	38.10	197.0	1 453.86	129.4	954.97
21	1 1/4	31.75	108.8	802.94	74.5	549.81
22	2 1/4	57.15	678.8	5 009.54	434.5	3 206.61
23	2 1/4	57.15	678.8	5 009.54	434.5	3 206.61
24	1 5/8	41.28	251.0	1 852.38	162.8	1 201.46
25	7/8	22.23	36.2	267.16	24.5	180.81
26	4	101.60	3866.0	28 531.08	2427.0	17 911.26
27	3 1/4	82.55	2062.0	15 217.56	1302.0	9 608.76
28	3	76.20	1628.0	12 014.64	1031.0	7 608.78

daN.m \times 7.38 = lb.ft

CAMERON RAM-TYPE BLOW-OUT PREVENTERS

Operating data

Model	Nominal size	Working pressure	Fluid volume to open rams		Fluid volume to close rams		Closing ratio	Opening ratio
	(in)	(psi)	(gal)	(liters)	(gal)	(liters)		
Type U	7 1/16	3 000 to 15 000	1.3	4.9	1.3	4.9	6.9	2.2
	11	3 000 to 10 000	3.4	12.9	3.5	13.2	7.3	2.5
	11	15 000	6.1	23.1	6.2	23.5	9.8	2.2
	13 5/8	3 000 to 10 000	5.4	20.4	5.8	22.0	7.0	2.3
	13 5/8	15 000	10.4	39.4	10.6	40.1	10.6	3.6
	16 3/4	3 000 and 5 000	9.8	37.1	10.6	40.1	6.8	2.3
	16 3/4	10 000	11.6	43.9	12.4	46.9	6.8	2.3
	18 3/4	10 000	21.2	80.2	23.1	87.4	7.4	3.7
	20 3/4	3 000	7.9	29.9	8.4	31.8	7.0	1.3
	21 1/4	2 000						
	21 1/4	5 000	27.2	103.0	29.9	113.2	6.2	4.0
	21 1/4	10 000	24.5	92.7	26.9	101.8	7.2	4.0
26 3/4	3 000	10.1	38.2	10.8	40.9	7.0	1.0	
Type U special cavity (shear ram)	11	3 000 to 10 000	7.4	28.0	7.6	28.8	12.0	4.8
	11	15 000	8.9	33.7	9.0	34.1	15.2	3.7
	13 5/8	3 000 to 10 000	10.5	39.7	10.9	41.3	10.8	4.5
	13 5/8	15 000	16.0	60.6	16.2	61.3	16.2	6.0
	16 3/4	3 000 and 5 000	18.1	68.5	19.0	71.9	10.4	4.4
	16 3/4	10 000	18.2	68.9	19.1	72.3	10.4	4.4
	20 3/4	3 000	14.3	54.1	14.9	56.4	10.8	1.7
21 1/4	2 000							
Type UII	18 3/4	10 000	22.3	84.4	24.7	93.5	6.7	2.5
	18 3/4	15 000	32.3	122.3	34.7	131.4	9.3	3.5
Type T	18 3/4	15 000	22.2	84.0	24.2	91.6	6.7	3.1

HYDRIL RAM-TYPE BLOW-OUT PREVENTERS

Operating data

Model	Nominal size	Working pressure	Fluid volume to open rams		Fluid volume to close rams		Closing ratio	Opening ratio
	(in)		(psi)	(gal)	(liters)	(gal)		
Manual-Lock	7 1/16	3 000 and 5 000	0.93	3.5	1.0	3.8	4.8	1.5
	7 1/16	10 000	1.80	6.8	1.9	7.2	7.7	1.7
	7 1/16	15 000	3.40	12.9	3.7	14.0	7.1	6.6
	9	3 000 and 5 000	1.90	7.2	1.9	7.2	4.5	2.6
	11	3 000 and 5 000	3.20	12.1	3.3	12.5	6.0	2.0
	11	10 000	5.00	18.9	5.2	19.7	6.9	2.4
	11	15 000	8.10	30.7	8.8	33.3	7.2	3.24
	13 5/8	3 000 and 5 000	4.90	18.5	5.4	20.4	4.8	2.1
	13 5/8	10 000	11.80	44.7	11.8	44.7	10.2	3.8
	20 3/4	3 000	7.20	27.3	8.1	30.7	4.75	0.98
	21 1/4	2 000						
21 1/4	5 000	16.60	62.8	17.5	66.2	10.2	1.9	
Manual-Lock Shear rams	11	3 000 and 5 000	5.00	18.9	5.5	20.8	5.6	4.2
	11	10 000	8.20	31.0	8.8	33.3	11.7	4.0
	11	15 000	8.10	30.7	8.8	33.3	7.2	3.24
	13 5/8	3 000 and 5 000	11.20	42.4	11.5	43.5	10.1	4.7
	20 3/4	3 000	16.30	61.7	17.2	65.1	10.14	2.2
	21 1/4	2 000						
	21 1/4	5 000	16.60	62.8	17.5	66.2	10.2	1.9
MPL	7 1/16	3 000 and 5 000	0.93	3.5	1.2	4.5	5.4	1.5
	7 1/16	10 000	1.80	6.8	2.0	7.6	8.2	1.7
	7 1/16	15 000	3.40	12.9	3.9	14.8	7.6	6.6
	9	3 000 and 5 000	1.90	7.2	2.2	8.3	5.3	2.6

HYDRIL RAM-TYPE BLOW-OUT PREVENTERS (continued)

Operating data

Model	Nominal size	Working pressure	Fluid volume to open rams		Fluid volume to close rams		Closing ratio	Opening ratio
	(in)	(psi)	(gal)	(liters)	(gal)	(liters)		
MPL	11	3 000 and 5 000	3.20	12.1	3.7	14.0	6.80	2.00
	11	10 000	5.00	18.9	5.7	21.6	7.60	2.40
	11	15 000	8.10	30.7	9.3	35.2	7.60	3.24
	13 5/8	3 000	4.90	18.5	5.9	22.3	5.20	2.10
	13 5/8	5 000	5.20	19.7	5.9	22.3	5.20	2.10
	13 5/8	10 000	11.80	44.7	12.9	48.8	10.60	3.80
	13 5/8	15 000	11.00	41.6	12.6	47.7	7.74	3.56
	16 3/4	10 000	14.10	53.4	15.6	59.1	10.60	2.41
	18 3/4	10 000	15.60	59.1	17.1	64.7	10.60	1.90
	18 3/4	15 000	16.70	63.2	19.4	73.4	7.27	2.15
	20 3/4	3 000	7.20	27.3	8.9	33.7	5.20	0.98
	21 1/4	2 000						
21 1/4	5 000	16.60	62.8	19.3	73.1	10.60	1.90	
Manual-Lock Shear rams	11	3 000 and 5 000	5.00	18.9	6.0	22.7	6.00	4.20
	11	10 000	8.20	31.0	9.3	35.2	12.40	4.00
	11	15 000	8.10	30.7	9.3	35.2	7.60	3.24
	13 5/8	3 000 and 5 000	11.20	42.4	12.0	45.4	10.60	4.70
	13 5/8	10 000	11.80	44.7	12.9	48.8	10.60	3.80
	13 5/8	15 000	11.00	41.6	12.6	47.7	7.74	3.56
	16 3/4	10 000	14.10	53.4	15.6	59.1	10.60	2.40
	18 3/4	10 000	15.60	59.1	17.1	64.7	10.60	1.90
	18 3/4	15 000	16.70	63.2	19.4	73.4	7.27	2.15
	20 3/4	3 000	16.30	61.7	18.0	68.1	10.60	2.20
	21 1/4	2 000						
	21 1/4	5 000	16.60	62.8	19.3	73.1	10.60	1.90

NL SHAFFER BLOW-OUT PREVENTERS

Operating data

Model	Nominal size	Working pressure	Fluid volume to open rams		Fluid volume to close rams		Closing ratio	Opening ratio	Ram size
	(in)		(psi)	(gal)	(liters)	(gal)			(liters)
Sentinel	7 1/4	3 000	0.28	1.1	0.29	1.1	4.00	2.50	–
LWP	7 1/16	3 000	0.51	1.9	0.55	2.1	4.49	2.50	5
	9	3 000	0.68	2.6	0.77	2.9	4.49	1.81	5
SL Posilock and Manual-Lock	7 1/16	10 000	2.34	8.9	2.72	10.3	7.11	3.37	10
	7 1/16	10 000	5.57	21.1	6.00	22.7	13.94	7.14	14
	7 1/16	15 000	2.34	8.9	2.72	10.3	7.11	3.37	10
	7 1/16	15 000	5.57	21.1	6.00	22.7	13.94	7.14	14
	11	10 000	7.00	26.5	9.45	35.8	7.11	4.62	14
	11	15 000	8.10	30.7	9.40	35.6	7.11	2.80	14
	13 5/8	3 000	4.46	16.9	5.44	20.6	5.54	3.00	10
	13 5/8	5 000	4.46	16.9	5.44	20.6	5.54	3.00	10
	13 5/8	5 000	10.52	39.8	11.00	41.6	10.85	10.02	14
	13 5/8	10 000	10.52	39.8	10.58	40.0	7.11	4.29	14
	13 5/8	15 000	10.52	39.8	11.56	43.8	7.11	2.14	14
	16 3/4	5 000	4.97	18.8	6.07	23.0	5.54	2.03	10
	16 3/4	5 000	10.67	40.4	11.76	44.5	10.85	5.77	14
	16 3/4	10 000	12.50	47.3	14.47	54.8	7.11	2.06	14
	18 3/4	10 000	13.21	50.0	14.55	55.1	7.11	1.83	14
	18 3/4	15 000	13.33	50.5	14.62	55.3	10.85	1.68	14
21 1/4	10 000	13.86	52.5	16.05	60.8	7.11	1.63	14	
LWS Posilock and Manual-Lock	4 1/16	5 000 and 10 000	0.52	2.0	0.59	2.2	8.45	4.74	6
	7 1/16	5 000	1.18	4.5	1.45	5.5	5.45	1.93	6 1/2
	7 1/16*	10 000	5.25	19.9	5.18	19.6	10.63	15.22	14
	9	5 000	2.27	8.6	2.58	9.8	5.57	3.00	8 1/2
	11	3 000	1.45	5.5	1.74	6.6	5.45	1.16	6 1/2
	11	5 000	2.62	9.9	2.98	11.3	5.57	2.09	8 1/2
	11	5 000	8.9	33.7	9.50	36.0	16	3.41	14
	20 3/4	3 000	4.46	16.9	5.07	19.2	5.57	0.78	8 1/2
	20 3/4	3 000	6.86	26.0	7.80	29.5	8.16	1.15	10
	20 3/4	3 000	13.59	51.4	14.50	54.9	16	2.21	14
	21 1/4	2 000	4.46	16.9	5.07	19.2	5.57	0.78	8 1/2
	21 1/4	2 000	6.86	26.0	7.80	29.5	8.16	1.15	10
	21 1/4	2 000	13.59	51.4	14.50	54.9	16	2.21	14

* Replaced by 7 1/16 inch, 10 000 psi type SL.

KOOMEY RAM-TYPE BLOW-OUT PREVENTERS

Operating data

Model	Nominal size	Working pressure	Fluid volume to open rams		Fluid volume to close rams		Closing ratio	Opening ratio
	(in)		(psi)	(gal)	(liters)	(gal)		
PB-PRC (Power ram change)	7 1/16	3 000	0.96	3.6	1.02	3.9	4.62	1.50
	7 1/16	5 000	0.96	3.6	1.02	3.9	0.69	0.50
	7 1/16	10 000	0.96	3.6	1.02	3.9	7.75	2.50
	13 5/8	3 000	5.78	21.9	6.25	23.7	4.62	1.50
	13 5/8	5 000	5.78	21.9	6.25	23.7	7.69	2.50
	13 5/8	10 000	5.78	21.9	6.25	23.7	7.75	2.50
PL-PRC (Power ram change)	7 1/16	3 000	0.97	3.7	1.10	4.2	4.62	1.50
	7 1/16	5 000	0.97	3.7	1.10	4.2	7.69	2.50
	7 1/16	10 000	0.97	3.7	1.10	4.2	7.75	2.50
	11	3 000	3.30	12.5	3.60	13.6	4.44	1.50
	11	5 000	3.30	12.5	3.60	13.6	7.41	2.50
	11	10 000	3.30	12.5	3.60	13.6	7.41	2.50
	13 5/8	5 000	5.78	21.9	6.25	23.7	7.69	2.50
	13 5/8	10 000	5.78	21.9	6.25	23.7	7.75	2.50
PL hinged	7 1/16	15 000	0.75	2.8	0.75	2.8	30.00	18.99
	11	15 000	2.66	10.1	2.66	10.1	42.86	16.72
	13 5/8	10 000	2.80	10.6	2.80	10.6	28.57	20.75
	13 5/8	15 000	3.54	13.4	3.54	13.4	42.86	25.00
	18 3/4	10 000	11.50	43.5	11.50	43.5	30.00	25.00
	18 3/4	15 000	11.50	43.5	11.50	43.5	30.00	25.00
	20 3/4	3 000	12.18	46.1	12.65	47.9	1.48	0.75
	21 1/4	2 000	9.20	34.8	9.20	34.8	4.00	2.00
	21 1/4	5 000	9.70	36.7	9.70	36.7	4.94	1.60
	21 1/4	10 000	4.40	16.7	4.40	16.7	18.32	13.30

CAMERON RAM-TYPE BLOW-OUT PREVENTERS

Dimensions and weights

Model	Nominal size (in)	Working pressure (psi)	Width bonnets closed locking rams screwed		Width bonnets open locking rams unscrewed		Single BOP				Double BOP			
			(in)	(cm)	(in)	(cm)	Height between flanges (in)	Height between flanges (cm)	Approximate weight		Height between flanges (in)	Height between flanges (cm)	Approximate weight	
									(lb)	(kg)			(lb)	(kg)
Type U	7 1/16	3 000	74.000	188.0	109.500	278.1	24.062	61.1	2 600	1 179	41.000	104.1	5 000	2 268
	7 1/16	5 000	74.000	188.0	109.500	278.1	27.500	69.9	2 800	1 270	44.188	112.2	5 200	2 359
	7 1/16	10 000	74.000	188.0	109.500	278.1	30.562	77.6	3 550	1 610	48.625	123.5	6 400	2 903
	7 1/16	15 000	74.000	188.0	109.500	278.1	31.812	80.8	3 800	1 724	49.875	126.7	6 750	3 062
	11	3 000	96.250	244.5	146.875	373.1	29.062	73.8	5 300	2 404	49.250	125.1	9 900	4 491
	11	5 000	96.250	244.5	146.875	373.1	34.312	87.2	5 600	2 540	54.500	138.4	10 200	4 627
	11	10 000	96.250	244.5	146.875	373.1	35.688	90.6	6 400	2 903	55.875	141.9	11 300	5 126
	11 (Mod 79)	15 000	124.000	315.0	175.312	445.3	44.812	113.8	10 300	4 672	69.750	177.2	18 400	8 346
	13 5/8	3 000	112.125	284.8	171.500	435.6	31.312	79.5	7 200	3 266	53.375	135.6	14 300	6 486
	13 5/8	5 000	112.125	284.8	171.500	435.6	33.812	85.9	7 700	3 493	55.875	141.9	14 800	6 713
	13 5/8	10 000	114.125	289.9	172.750	438.8	41.688	105.9	10 300	4 672	66.625	169.2	18 400	8 346
	13 5/8 (Mod B)	15 000	139.000	353.1	214.375	544.5	53.688	136.4	23 700	10 750	81.750	207.6	43 250	19 618
	16 3/4 (Mod B)	3 000	127.250	323.2	204.562	519.6	40.062	101.8	13 700	6 214	65.875	167.3	26 650	12 088
	16 3/4 (Mod B)	5 000	129.250	328.3	202.125	513.4	43.062	109.4	13 750	6 237	68.875	174.9	26 940	12 220
	16 3/4	10 000	139.000	353.1	218.375	554.7	46.688	118.6	23 300	10 569	77.750	197.5	43 500	19 732
	18 3/4	10 000	156.375	397.2	242.125	615.0	56.000	142.2	28 900	13 109	87.125	221.3	56 950	25 833
20 3/4	3 000	143.688	365.0	226.812	576.1	40.562	103.0	13 650	6 192	66.125	168.0	25 550	11 589	
21 1/4	2 000	143.688	365.0	226.812	576.1	37.188	94.5	13 250	6 010	62.750	159.4	25 150	11 408	
21 1/4	5 000	164.250	417.2	247.250	628.0	50.938	129.4	30 000	13 608	82.375	209.2	58 000	26 309	
21 1/4	10 000	163.375	415.0	250.375	636.0	66.000	167.6	34 650	15 717	100.062	254.2	65 500	29 711	
26 3/4	3 000	169.625	430.8	275.375	699.5	48.312	122.7	24 000	10 886	78.875	200.3	44 200	20 049	
Type U II	18 3/4	10 000	147.000 (1)	373.4	185.500 (1)	471.2	43.125 (2)	109.5			87.125	221.3	51 809	23 501
	18 3/4	15 000	148.375 (1)	376.9	186.875 (1)	474.7	64.750	164.5			74.000 (2)	188.0	50 706	23 000
						53.125 (2)	134.9				98.875	251.1	71 209	32 300
Type T	18 3/4	15 000	177.000 (1)	449.6	217.000 (1)	551.2	64.200	163.1			98.100	249.2	87 744	39 801
							53.000 (2)	134.6				87.000 (2)	221.0	85 980

(1) With Wedge Lock system.
 (2) Clamped upper and lower connections.

HYDRIL RAM-TYPE BLOW-OUT PREVENTERS

Dimensions and weights

Nominal size (in)	Working pressure (psi)	Width bonnets closed L		Bonnets radius U		Single BOP			Double BOP		
		(in)	(cm)	(in)	(cm)	Height between flanges H (in)	Approximate weight (lb)	(kg)	Height between flanges H (in)	Approximate weight (lb)	(kg)
7 1/16	3 000	77 1/16	195.7	36 3/16	91.9	22 9/16	2 350	1 066	35 9/16	4 910	2 227
7 1/16	5 000	77 1/16	195.7	36 3/16	91.9	24 1/4	2 465	1 118	37 3/8	4 930	2 236
7 1/16	10 000	79	200.7	37 3/16	94.5	29 1/4	5 600	2 540	46	10 600	4 808
7 1/16	15 000	86 3/16	218.9	42 3/8	107.6	34 3/16	5 370	2 436	54 5/8	10 200	4 627
9	3 000	82 1/2	209.6			28 3/16	5 200	2 359	48 9/16	10 200	4 627
9	5 000	82 1/2	209.6			31 11/16	5 400	2 449	52 1/16	10 400	4 717
11	3 000	95	241.3	44 5/8	113.3	30 1/4	5 600	2 540	49 3/4	10 800	4 899
11	5 000	95	241.3	44 5/8	113.3	35 1/2	6 000	2 722	55	12 000	5 443
11	10 000	106 1/4	269.9	62 1/2	158.8	36 1/4	9 750	4 423	56 7/8	18 100	8 210
11	15 000	114 13/16	291.6	44 5/8	113.3	47 1/8	15 900	7 212	74 9/16	28 200	12 792
13 5/8	3 000	116 3/4	296.5	52 1/4	132.7	33 1/4	8 450	3 833	55 1/8	16 300	7 394
13 5/8	5 000	116 3/4	296.5	52 1/4	132.7	36 1/4	8 850	4 014	58 1/8	16 700	7 575
13 5/8	10 000	124 3/4	316.9	58 1/4	148.0	41 3/4	17 000	7 711	66 3/4	37 000	16 783
13 5/8	15 000	*119 1/8	302.6	45 3/8	115.3	51 3/8	21 150	9 594	80 5/8	41 150	18 666
16 3/4	10 000	143	363.2	61 5/16	155.7	44 7/8	21 000	9 526	73	43 000	19 505
18 3/4	10 000	*138 1/4	351.2	62	157.5	54 1/4	28 500	12 928	85 3/4	52 000	23 587
18 3/4	15 000	*150 3/4	382.9	**65 15/16	167.5	65 1/2	31 900	14 470	103 1/2	62 750	28 463
20 3/4	3 000	151 1/2	384.8	59 3/4	151.8	38 1/2	14 500	6 577	83 1/2	28 000	12 701
21 1/4	2 000	151 1/2	384.8	59 3/4	151.8	35 1/4	14 000	6 350	60 1/4	27 000	12 247
21 1/4	5 000	148	375.9	66	167.6	47	18 000	8 165	75 1/4	32 000	14 515

Note: L dimensions correspond to Manual-Lock types unless marked by an asterisk *.
 **: Dimension U of type MPL.

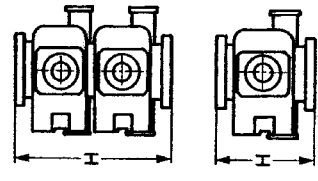
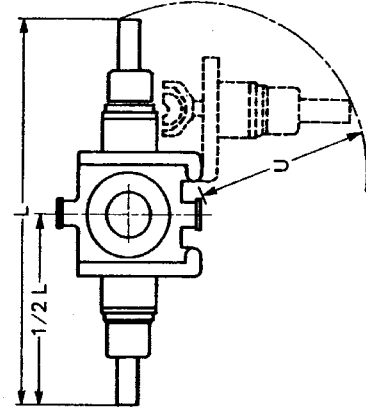

NL SHAFFER RAM-TYPE BLOW-OUT PREVENTERS

Dimensions and weights

Model	Nominal size (in)	Working pressure (psi)	Width bonnets closed L		Overall dimensions bonnets open G		Single BOP			Double BOP			Piston size (in)		
			(in)	(cm)	(in)	(cm)	Height between flanges (in)	(cm)	Approximate weight (lb)	(kg)	Height between flanges (in)	(cm)		Approximate weight (lb)	(kg)
Sentinel	**7 1/4	3 000	61 7/8	157.2	-	-	10	25.4	1 152	523	18 1/2	47.0	2 095	950	
	7 1/16	3 000	52 3/8	133.0	33 1/2	85.1	19 1/8	48.6	1 176	533	30 1/2	77.5	2 078	943	
LWP	9	3 000	60 1/8	152.7	33 7/16	84.9	21 7/16	54.5	1 430	649	32 3/8	82.2	2 460	1 116	
	7 1/16	10 000	79	200.7	46	116.8	39 1/4	99.7	6 200	2 812	53	134.6	10 250	4 649	10
SL POSLOCK and Manual - Lock	7 1/16	10 000	135 3/4	344.8	66 1/16	-	39 1/4	99.7	7 550	3 425	-	-	-	-	14
	7 1/16	15 000	79	200.7	46	-	39 1/4	99.7	6 200	2 812	53	134.6	10 250	4 649	10
	7 1/16	15 000	135 3/4	344.8	66 1/16	167.8	39 1/4	99.7	7 550	3 425	-	-	-	-	14

* Poslock type. All others: Manual-Lock type.
 ** Hydraulic control.

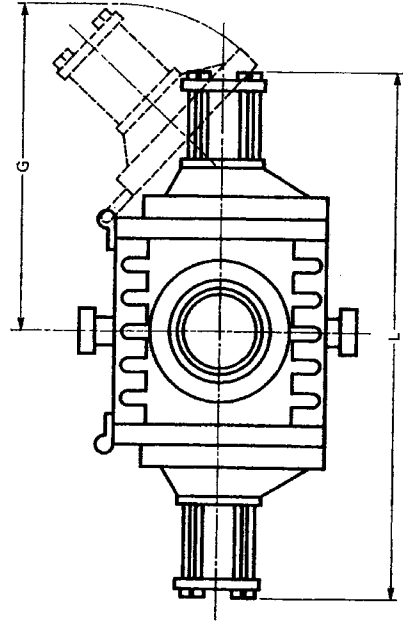

NL SHAFFER RAM-TYPE BLOW-OUT PREVENTERS (continued) Dimensions and weights

Model	Nominal size (in)	Working pressure (psi)	Width bonnets closed L (in, cm)		Overall dimensions bonnets open G (in, cm)		Single BOP			Double BOP			Piston size (in)	
			(in)	(cm)	(in)	(cm)	Height between flanges (in)	(cm)	(lb)	(kg)	Height between flanges (in)	(cm)		(lb)
SL POSLOCK and Manual-Lock	11	10 000	122 3/4	311.8	65	165.1	42 7/8	108.9	12 695	5 758	60 1/4	153.0	21 780	9 879
	11	15 000	135 7/32	343.5	72 21/64	183.7	57	144.8	24 655	11 184	75 1/2	191.8	37 750	17 123
	13 5/8	3 000	130 1/4	330.8	68 1/16	172.9	30 5/8	77.8	8 430	3 824	47 3/8	120.3	16 054	7 282
	13 5/8	5 000	130 1/4	330.8	68 1/16	172.9	33 3/8	84.8	8 985	4 076	50 1/8	127.3	16 608	7 533
	13 5/8	5 000	*108	274.3	64 3/8	163.5	33 3/8	84.8	10 110	4 586	50 1/8	127.3	18 860	8 555
	13 5/8	10 000	128 3/4	327.0	68 3/4	174.6	48 1/8	122.2	15 295	6 938	66 1/8	168.0	25 365	11 506
	13 5/8	15 000	142 3/4	362.6	77 1/2	196.9	64 1/2	163.8	29 050	13 177	84 1/4	214.0	45 130	20 471
	16 3/4	5 000	141 1/2	359.4	75 11/16	192.2	43 1/2	110.5	15 460	7 013	61 3/8	155.9	26 648	12 088
	16 3/4	5 000	*118 3/8	300.7	71 11/16	182.1	43 1/2	110.5	-	-	61 3/8	155.9	-	-
	16 3/4	10 000	*127 1/4	323.2	79 5/16	201.5	55 7/8	141.9	28 420	12 891	74 1/8	188.3	43 790	19 863
	18 3/4	10 000	*129 3/8	328.6	81	205.7	60 1/4	153.0	30 700	13 926	78	198.3	48 488	21 994
	18 3/4	15 000	*134 3/4	342.3	77 3/4	197.5	-	-	-	-	92 1/2	235.0	60 000	27 216
21 1/4	10 000	*136 1/4	346.1	84 1/8	213.7	69 1/2	176.5	37 285	16 912	88 3/4	225.4	54 860	24 884	

* Poslock type. All others: Manual-Lock type.

NL SHAFFER RAM-TYPE BLOW-OUT PREVENTERS (continued) Dimensions and weights

Model	Nominal size (in)	Working pressure (psi)	Width bonnets closed L		Overall dimensions bonnets open G		Single BOP			Double BOP			Piston size (in)	
			(in)	(cm)	(in)	(cm)	Height between flanges (in)	(cm)	Approximate weight (lb)	(kg)	Height between flanges (in)	(cm)		Approximate weight (lb)
SL POSLOCK and Manual-Lock	4 1/16	5 000 and 10 000	42 1/4	107.3	23 13/16	60.5	20 3/4	52.7	975	442	-	-	-	-
	7 1/16	5 000	58 1/4	148.0	32 1/2	82.6	28 1/4	71.8	1 585	719	40	101.6	2 706	1 227
	7 1/16	10 000	74 3/4	189.9	43 3/8	110.2	39 7/8	101.3	6 665	3 023	59 5/8	151.4	12 435	5 641
	9	5 000	79 1/8	201.0	46 5/16	117.6	30 1/8	76.5	3 230	1 465	47 7/16	120.5	6 110	2 771
	11	3 000	72 5/8	184.5	39 31/32	101.5	27 1/8	68.9	2 580	1 170	42	106.7	4 560	2 068
	11	5 000	89 1/4	226.7	46 5/16	117.6	37	94.0	4 820	2 186	50 1/2	128.3	8 385	3 803
	11	5 000	*101 1/4	257.2	57	144.8	37	94.0	6 670	3 026	50 1/2	128.3	-	-
	20 3/4	3 000	127 1/2	323.9	67 5/8	171.8	41 5/8	105.7	8 550	3 878	67 3/4	172.1	15 715	7 128
	20 3/4	3 000	*117 1/8	297.5	67 7/8	172.4	41 5/8	105.7	8 912	4 042	67 3/4	172.1	16 440	7 457
	20 3/4	3 000	*132 1/8	335.6	73 5/8	187.0	41 5/8	105.7	11 170	5 067	67 3/4	172.1	20 995	9 523
	21 1/4	2 000	127 1/2	323.9	67 5/8	171.8	37 3/4	95.9	7 985	3 622	63 7/8	162.2	15 155	6 874
	21 1/4	2 000	*117 1/4	297.8	67 7/8	172.4	37 3/4	95.9	8 347	3 786	63 7/8	162.2	15 880	7 203
	21 1/4	2 000	*132 1/4	335.9	75 1/8	190.8	37 3/4	95.9	10 605	4 810	63 7/8	162.2	20 400	9 253

* Poslock type. All others: Manual-Lock type.

KOOMEY RAM-TYPE BLOW-OUT PREVENTERS

Dimensions and weights

Model	Nominal size (in)	Working pressure (psi)	Width bonnets closed L		Overall dimensions bonnets open C or H		Single BOP				Double BOP			
			(in)	(cm)	(in)	(cm)	Height between flanges		Approximate weight		Height between flanges		Approximate weight	
							(in)	(cm)	(lb)	(kg)	(in)	(cm)	(lb)	(kg)
P l i n g e d	7 1/16	3 000	69.625	176.8	73.375	186.4	20.250	51.4	1 205	547	30.250	76.8	2 146	973
	7 1/16	5 000	69.625	176.8	73.375	186.4	24.000	61.0	1 600	726	34.125	86.7	2 800	1 270
	7 1/16	10 000	69.625	176.8	73.375	186.4	25.125	63.8	1 764	800	35.625	90.5	3 430	1 556
	13 5/8	3 000	136.625	347.0	143.500	364.5	27.125	68.9	7 246	3 287	44.250	112.4	13 714	6 221
	13 5/8	5 000	136.625	347.0	143.500	364.5	32.125	81.6	7 924	3 594	49.250	125.1	14 392	6 528
	13 5/8	10 000	136.625	347.0	143.500	364.5	38.937	98.9	9 650	4 377	54.437	138.3	15 816	7 174
	7 1/16	3 000	68.940	175.1	86.940	220.8	19.500	49.5	1 816	824	31.000	78.7	3 692	1 675
	7 1/16	5 000	68.940	175.1	86.940	220.8	22.750	57.8	1 700	771	34.250	87.0	3 230	1 465
P L- P R C (Power Ram Change)	7 1/16	10 000	68.940	175.1	86.940	220.8	25.125	63.8	2 325	1 055	36.625	93.0	4 201	1 906
	11	3 000	102.580	260.6	126.875	322.3	26.500	67.3	5 120	2 322	40.875	103.8	9 610	4 359
	11	5 000	102.580	260.6	126.875	322.3	31.750	80.6	5 582	2 532	46.125	117.2	10 072	4 569
	11	10 000	102.580	260.6	126.875	322.3	33.630	85.4	6 313	2 864	48.000	121.9	10 804	4 901
	13 5/8	5 000	126.750	321.9	157.500	400.1	35.000	88.9	7 033	3 190	52.125	132.4	12 612	5 721
	13 5/8	10 000	126.750	321.9	157.500	400.1	36.750	93.3	-	-	53.880	136.9	-	-

KOOMEY RAM-TYPE BLOW-OUT PREVENTERS (continued) Dimensions and weights

Model	Nominal size (in)	Working pressure (psi)	Width bonnets closed L		Width bonnets open C or H		Single BOP				Double BOP			
			(in)	(cm)	(in)	(cm)	Height between flanges H		Approximate weight		Height between flanges H		Approximate weight	
							(in)	(cm)	(lb)	(kg)	(in)	(cm)	(lb)	(kg)
PB-PRC (Power Ram Change)	7 1/16	15 000	91.750	233.0	111.000	281.9	28.375	72.1	3 200	1 452	40.875	103.8	5 825	2 642
	11	15 000	143.500	364.5	172.500	438.2	42.250	107.3	14 500	6 577	61.370	155.9	25 000	11 340
	13 5/8	10 000	136.000	345.4	166.500	422.9	39.375	100.0	11 678	5 297	56.500	143.5	20 520	9 308
	13 5/8	15 000	149.000	378.5	184.500	468.6	49.250	125.1	19 698	8 935	73.750	187.3	35 699	16 193
	18 3/4	10 000	199.125	505.8	249.125	632.8	54.560	138.6	37 274	16 907	84.250	214.0	69 524	31 536
	18 3/4	15 000	199.125	505.8	249.125	632.8	64.375	163.5	50 258	22 797	96.000	243.8	94 070	42 670
	20 3/4	3 000	212.000	538.5	260.000	660.4	36.000	91.4	18 826	8 539	55.130	140.0	35 657	16 174
	21 3/4	2 000	212.000	538.5	260.000	660.4	33.000	83.8	14 530	6 591	51.880	131.8	27 401	12 429
	21 1/4	5 000	198.000	502.9	246.000	624.8	54.500	138.4	33 698	15 285	81.750	207.6	62 418	28 313
	21 1/4	10 000	214.000	543.6	264.000	670.6	56.000	142.2	37 930	17 205	85.000	215.9	66 650	30 232

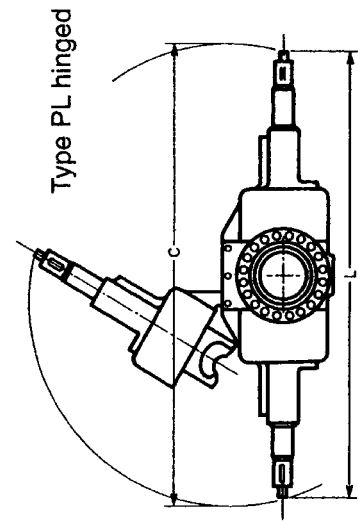

Type PL hinged

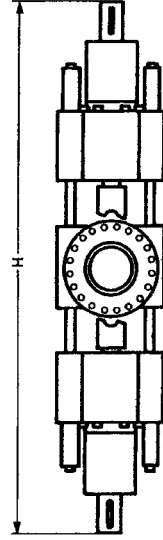

CAMERON TYPE D ANNULAR BLOW-OUT PREVENTERS

Dimensions and operating data

Model	Nominal size (in)	Working pressure (psi)	Overall height flanged		Diameter		Weight		Closing fluid volume		Opening fluid volume	
			(in)	(cm)	(in)	(cm)	(lb)	(kg)	(gal)	(liters)	(gal)	(liters)
D	7 1/16	3 000	23 15/16	60.8	27 7/8	70.8	2 738	1 242	1.69	6.4	1.30	4.9
	7 1/16	5 000	25 1/2	64.8	27 7/8	70.8	2 778	1 260	1.69	6.4	1.69	6.4
	7 1/16	10 000	34 7/32	86.9	37 3/8	94.9	7 255	3 291	2.94	11.1	2.55	9.7
	7 1/16	15 000	44 3/4	113.7	43 1/4	109.9	12 000	5 443	6.94	26.3	6.12	23.2
	7 1/16	20 000	50 3/4	128.9	48	121.9	17 716	8 036	8.38	31.7	7.56	28.6
	11	3 000	32 1/2	82.6	41 1/4	104.8	8 255	3 744	5.65	21.4	4.69	17.8
	11	5 000	34 15/16	88.7	41 1/4	104.8	8 447	3 832	5.65	21.4	4.69	17.8
	11	10 000	41 1/16	104.3	48 1/2	123.2	13 954	6 330	10.15	38.4	9.06	34.3
	11	15 000	62 1/2	158.8	61	154.9	35 500	16 103	23.50	88.9	21.30	80.6
	13 5/8	3 000	36 11/16	93.2	50	127.0	12 885	5 845	12.12	45.9	10.34	39.1
	13 5/8	5 000	40 3/16	102.1	52 3/8	133.0	16 215	7 355	12.12	45.9	10.34	39.1
	13 5/8	10 000	49 3/32	124.7	61	154.9	27 262	12 366	18.10	68.5	16.15	61.1
	13 5/8	15 000	67 1/4	170.8	65 3/4	167.0	36 000	16 330	26.00	98.4	22.50	85.2
	16 3/4	3 000	47	119.4	60 1/2	153.7	25 950	11 771	22.32	84.5	19.00	71.9
	16 3/4	5 000	49	124.5	60 1/2	153.7	26 300	11 930	22.32	84.5	19.00	71.9
	16 3/4	10 000	65 1/2	166.4	63	160.0	35 300	16 012	40.75	154.2	35.42	134.1
	18 3/4	5 000	60 13/16	154.5	62	157.5	17 716	8 036	35.60	134.7	29.00	109.8
	18 3/4	10 000	70 1/2	179.1	67	170.2	40 940	18 570	51.00	193.0	45.10	170.7
	20 3/4	3 000	54 3/4	139.1	66	167.6	20 000	9 072	39.70	150.3	24.10	91.2
	21 1/4	2 000	53 5/16	135.4	66	167.6	19 800	8 981	39.70	150.3	24.10	91.2

HYDRIL ANNULAR BLOW-OUT PREVENTERS

Dimensions and operating data

Model	Nominal size (in)	Working pressure (psi)	Overall height flanged		Diameter		Weight		Closing fluid volume		Opening fluid volume		Secondary chamber	
			(in)	(cm)	(in)	(cm)	(lb)	(kg)	(gal)	(liters)	(gal)	(liters)	(gal)	(liters)
GX	11	10 000	57.12	145.1	60.38	153.4	21 385	9 700	17.88	67.7	17.88	67.7	17.88	67.7
	11	15 000	-	-	67.12	170.5	-	-	24.14	91.4	24.14	91.4	24.14	91.4
	13 5/8	10 000	63.25	160.7	64.50	163.8	28 000	12 701	24.14	91.4	24.14	91.4	24.14	91.4
	13 5/8	15 000	77.00	195.6	73.25	186.1	-	-	34.00	128.7	34.00	128.7	34.00	128.7
	18 3/4	10 000	80.15	203.6	84.00	213.4	52 250	23 701	58.00	219.5	58.00	219.5	58.00	219.5
GL	13 5/8	5 000	52 3/16	132.6	56	142.2	17 320	7 856	19.76	74.8	19.76	74.8	19.76	74.8
	16 3/4	5 000	64 1/8 (1)	162.9	70 3/4	179.7	31 450	14 266	35.30	133.6	35.30	133.6	35.30	133.6
	16 3/4	5 000	110 1/8 (1)	279.7	70 3/4	179.7	55 000	24 948	35.30	133.6	35.30	133.6	35.30	133.6
	Dual													
	18 3/4	5 000	65 1/4	165.7	76 1/4	193.7	35 000	15 876	44.00	166.5	44.00	166.5	44.00	166.5
GK	18 3/4	5 000	112	284.5	76 1/4	193.7	63 100	28 622	44.00	166.5	44.00	166.5	44.00	166.5
	Dual													
	21 1/4	5 000	77 1/2	196.9	78 1/4	198.8	45 000	20 412	58.00	219.5	58.00	219.5	58.00	219.5
	7 1/16	3 000	32	81.3	32 1/4	81.9	2 715	1 232	2.85	10.8	2.24	8.5	2.24	8.5
	7 1/16	5 000	36 7/8	93.7	35 3/4	90.8	4 000	1 814	3.86	14.6	3.30	12.5	3.30	12.5
GK	7 1/16	10 000	48 1/8	122.2	49 1/2	125.7	12 200	5 534	9.42	35.7	7.08	26.8	7.08	26.8
	7 1/16	15 000	54 1/8	137.5	61	154.9	14 250	6 464	11.20	42.4	7.50	28.4	7.50	28.4
	7 1/16	20 000	59	149.9	58	147.3	23 000	10 433	10.90	41.3	7.20	27.3	7.20	27.3
	9 (2)	3 000	37 7/8	96.2	34 1/2	87.6	3 500	1 588	4.33	16.4	3.41	12.9	3.41	12.9
	9 (2)	5 000	41 3/4	106.0	41	104.1	6 000	2 722	6.84	25.9	5.80	22.0	5.80	22.0
	9	10 000	55 3/4	141.6	56 3/4	144.1	18 540	8 410	15.90	60.2	11.95	45.2	11.95	45.2
	11	3 000	39 3/4	101.0	40	101.6	5 500	2 495	7.43	28.1	5.54	21.0	5.54	21.0
	11	5 000	47 13/16	121.4	44 1/4	112.4	8 200	3 720	9.81	37.1	7.98	30.2	7.98	30.2
	11	5 000	48 1/4	122.6	44 1/4	112.4	-	-	9.81	37.1	7.98	30.2	7.98	30.2
	11	3 000	45 1/4	114.9	47 1/2	120.7	8 784	3 984	11.36	43.0	8.94	33.8	8.94	33.8
	13 5/8 (3)	3 000	45 1/4	114.9	47 1/2	120.7	-	-	11.36	43.0	8.94	33.8	8.94	33.8
	13 5/8 (3)	5 000	54 1/8	137.5	52 1/4	132.7	13 800	6 260	17.98	68.1	14.16	53.6	14.16	53.6
	13 5/8 (3)	5 000	54 1/2	138.4	52 1/4	132.7	13 250	6 010	17.98	68.1	14.16	53.6	14.16	53.6
	13 5/8 (4)	5 000	46 (5)	116.8	48 1/2	123.2	9 400 (5)	4 264	17.98	68.1	14.16	53.6	14.16	53.6
	16 3/4	5 000	61 1/4	155.6	59 1/2	151.1	20 835	9 451	28.70	108.6	19.93	75.4	19.93	75.4
16 3/4 (3)	5 000	61 19/64	155.7	59 1/2	151.1	21 230	9 630	28.70	108.6	19.93	75.4	19.93	75.4	

(1) Lowest flange of 10 000 psi series. (2) Previous models may have a vertical bore of 8 5/16 inches. (3) Latched head others screwed. (4) HL: special Helirig. (5) Equipped with a CIW lower hub.

HYDRIL ANNULAR BLOW-OUT PREVENTERS

Dimensions and operating data (continued)

Model	Nominal size		Working pressure		Overall height flanged		Overall diameter		Weight		Closing fluid volume		Opening fluid volume	
	(in)	(in)	(psi)	(psi)	(in)	(cm)	(in)	(cm)	(lb)	(kg)	(gal)	(liters)	(gal)	(liters)
MSP	7 1/16	25 3/4	2 000	2 000	65.41	75.88	29 7/8	75.88	1 850	839	2.85	10.8	1.98	7.5
	9	30 1/4	2 000	2 000	76.84	81.28	32	81.28	2 450	1 111	4.57	17.3	2.95	11.2
	11	31 1/4	2 000	2 000	79.38	94.62	37 1/4	94.62	3 520	1 597	7.43	28.1	5.23	19.8
	20 3/4 (1)	54 1/4	2 000	2 000	137.80	149.23	58 3/4	149.23	-	-	31.05	117.5	18.93	71.7
	21 1/4	52 1/2	2 000	2 000	133.35	149.23	58 3/4	149.23	15 100	6 849	31.05	117.5	18.93	71.7
	21 1/4 (2)	52 1/2	2 000	2 000	133.35	149.23	58 3/4	149.23	16 320	7 403	31.05	117.5	18.93	71.7
	21 1/4 (3)	48	2 000	2 000	121.92	155.58	61 1/4	155.58	12 700	5 761	31.75	120.2	19.25	72.9
	29 1/2	67 13/16	500	500	172.24	209.55	82 1/2	209.55	24 500	11 113	60.00	227.1	-	-
	30	58 1/8	1 000	1 000	147.64	229.87	90 1/2	229.87	32 500	14 742	87.60	331.6	27.8	105.2

(1) Available with latched head. Lower flange 3000 psi.

(2) Latched head.

(3) HL: special Helirig. Screw head and CIW lower hub.

HYDRIL ANNULAR BLOW-OUT PREVENTERS
Average closing pressure (psi) required to
establish initial seal-off in a surface installation

Type GL

Pipe outside diameter (in)	Nominal size of type GL (secondary chamber connected to opening chamber)											
	13 5/8 – 5000 psi				16 3/4 – 5000 psi				18 3/4 – 5000 psi			
	Well pressure (psi)				Well pressure (psi)				Well pressure (psi)			
	2000	3500	5000	2000	3500	5000	2000	3500	5000	2000	3500	5000
7	900	950	1100	700	825	950	700	825	950	700	825	950
5	900	950	1100	725	850	1000	800	900	1000	800	900	1000
3 1/2	1200	1200	1200	800	925	1050	1000	1050	1050	1000	1050	1100
Full closure	1400	1500	1500	1400	1500	1500	1400	1500	1500	1500	1500	1500

For optional hook-up in which the secondary chamber is connected to the closing chamber, the average pressures above must be multiplied by the coefficient S below:

GL – 5000 psi	13 5/8	16 3/4	18 3/4	21 1/4
S	0.71	0.68	0.69	0.66

HYDRIL ANNULAR BLOW-OUT PREVENTERS
Average closing pressure (psi) required to
establish initial seal-off in a surface installation (continued)

Type GK

Pipe outside diameter (in)	Nominal size and working pressure of type GK BOP																
	7 1/16 3000	7 1/16 5000	7 1/16 10 000	7 1/16 15 000	7 1/16 20 000	9 3000	9 5000	9 10 000	11 3000	11 5000	11 10 000	13 5/8 3000	13 5/8 5000	13 5/8 10 000	16 3/4 2000	16 3/4 3000	16 3/4 5000
6 5/8																	
5		400						350	450	450	500	700	600		350	450	
4 1/2	350	400							450	450	500	800	650	700	400	500	
3 1/2	400	450			2200	400			450	450	500	*900	*650	*700	*500	*500	*600
2 7/8	*400	*450			*2200	*500		*525	*550	*570	*700	1000	700	1200	600	600	650
2 3/8	500	500			2200	550		800	650	760	800	1100	750	1400	700	700	750
1.90	600	600			2200	650		900	750	860	1100		950	1400	800	800	850
1.66	700	700				750			920	850			1000	1500	900	950	950
Full closure	1000	1000				850			950	1000			1000	1500	1000	1000	1050
						1050		1150	1150	1150	1500	1200	1150	2200	1150	1150	1150

* For tests: pipe size and closing pressure recommended for maximum packing unit life.

HYDRIL ANNULAR BLOW-OUT PREVENTERS

Average closing pressure (psi) required to establish initial seal-off in a surface installation (continued)

Type MSP

Pipe outside diameter (in)	Nominal size and working pressure of MSP 2000 BOP			
	7 1/16 2000	9 2000	11 2000	21 1/4 2000
5 1/2	350	400	350	500
4 1/2	400	*500	450	*700
3 1/2	*400	550	*550	600
2 7/8	500	650	650	650
2 3/8	600	750	750	700
1.90	700	850	850	800
1.65	1000	1050	850	900
Full closure			1150	1000

***For tests:** pipe size and closing pressure recommended for maximum packing unit life.

Pipe outside diameter (in)	Initial closing pressure (psi) for MSP 29 1/2" - 500 psi BOP/ diverter (well pressure: 500 psi)		Initial closing pressure (psi) for MSP 30" - 1000 psi BOP/diverter	
	12	5	3 1/2 to 5	7 to 9 5/8
950	1350	1500	700	400
				20

Note: For tests, the recommended pipe diameter is 5 inches.

NL SHAFFER ANNULAR BLOW-OUT PREVENTERS

Dimensions and operating data

Model (1)	Nominal size (in)	Working pressure (psi)	Overall height flanged		Overall diameter		Weight		Closing fluid volume		Opening fluid volume	
			(in)	(cm)	(in)	(cm)	(lb)	(kg)	(gal)	(liters)	(gal)	(liters)
B	4 1/16	10 000	25 1/2	64.8	23	58.4	1 850	839	2.38	9.0	1.94	7.3
B	7 1/16	3 000	29 1/8	74.0	29	73.7	2 900	1 315	4.57	17.3	3.21	12.1
B	7 1/16	5 000	30 7/8	78.4	29	73.7	3 175	1 440	4.57	17.3	3.21	12.1
B	7 1/16	10 000	42 1/4	107.3	43	109.2	10 600	4 808	17.11	64.8	13.95	52.8
B	9	3 000	32 1/2	82.6	35 1/2	90.2	4 775	2 166	7.23	27.4	5.03	19.0
B	9	5 000	36 1/2	92.7	40	101.6	6 800	3 084	11.05	41.8	8.72	33.0
B	11	3 000	32 7/8	83.5	39 7/8	101.3	5 825	2 642	11.00	41.6	6.78	25.7
B	11	5 000	41 1/2	105.4	44 3/4	113.7	9 550	4 332	18.67	70.7	14.59	55.2
W	11	10 000	53	134.6	57	144.8	23 000	10 433	30.58	115.7	24.67	93.4
B	13 5/8	3 000	40 11/16	103.3	46 3/8	117.8	9 100	4 128	23.50	88.9	14.67	55.5
B	13 5/8	5 000	44 15/16	114.1	50	127.0	13 650	6 192	23.58	89.3	17.41	65.9
W	13 5/8	5 000	45 1/2	115.6	54	137.2	17 250	7 825	23.58	89.3	17.41	65.9
W	13 5/8	10 000	58 3/8	148.3	64 1/2	163.8	32 475	14 731	40.16	152.0	32.64	123.5
W	16 3/4	5 000	51 15/16	131.9	60	152.4	22 900	10 387	33.26	125.9	25.61	96.9
W	18 3/4	5 000	60	152.4	66 1/4	168.3	36 100	16 375	48.16	182.3	37.61	142.4
W	18 3/4	10 000	72 3/4	184.8	76 1/4	193.7	57 050	25 878	85.00	321.7	66.00	249.8
B	21 1/4	2 000	46 1/8	117.2	49	124.5	10 850	4 922	32.59	123.4	19.92	75.4
W	21 1/4	5 000	66 5/8	167.6	71	180.3	44 500	20 185	61.37	232.3	47.76	180.8
B	30	1 000	65 5/8	166.7	71	180.3	28 750	13 041	122.00	461.8	55.00	208.2

(1) B for bolted cover, W for wedge cover.

Closing pressure on casing (psi)

Nominal size (1) (in)	Well pressure (psi)	Casing size (in)												
		7	7 5/8	8 5/8	9 5/8	10 3/4	11 3/4	13 3/8	16	18 5/8	20			
21 1/4	5 000	1 500	1 400	1 175	975	790	640	480	300	190	150			
21 1/4	2 000	1 500	1 400	1 175	975	790	640	480	300	190	150			
18 3/4	10 000				385									
18 3/4	5 000	1 500	1 400	1 175	975	790	640	480	300					
16 3/4	5 000	1 500	1 400	1 175	975	790	640	480						
13 5/8	3 000/5 000	1 500	1 265	890	615	415	280							
30	1 000				1 100			1 100						900

(1) For other nominal sizes of Shaffer annular BOPs, no adjustment required to close on casing.

BOP CONTROL SYSTEM

Example of calculations for fluid capacity (IADC Drilling Manual, 11th edition, 1992)

I APPLICATION OF BOYLE'S LAW FOR CALCULATING STORED USABLE FLUID IN A SURFACE ACCUMULATOR BOTTLES

$$P_1 \times V_1 = P_2 \times V_2$$

P_1 = initial pressure (nitrogen pre-charge)

V_1 = initial gas volume

P_2 = pressure at a later time

V_2 = gas volume at a later time

Application:

Accumulator bottle pre-charge:	1000 psi	(P_1)
Accumulator capacity:	10 gallons	(V_1)
Minimum pressure required to operate BOP:	1200 psi	(P_2)
Maximum pressure in the bottle:	3000 psi	(P_3)

Usable fluid forced out of the bottle from 3000 psi to 1200 psi: $V_2 - V_3$

$$V_2 = P_1 \times V_1 / P_2 \qquad V_3 = P_1 \times V_1 / P_3$$

$$V_2 = 1000 \times 10 / 1200 \qquad V_3 = 1000 \times 10 / 3000$$

$$V_2 = 8.3 \text{ gallons.} \qquad V_3 = 3.3 \text{ gallons.}$$

Usable fluid : 5.0 gallons

II SIZING ACCUMULATOR SYSTEM FOR SURFACE BOP

Example of BOP stack:

Hydril GK 13 5/8-5 000 (L 33)
 Three U-13 5/8-10 000 (two rams and one shear ram) (L 20)

Annular gallons to close:	17.98
Two rams @ 5.8 gal each to close:	11.6
One shear ram to close:	10.9

Total: 40.48

Plus 50% Safety Factor:	20.24
-------------------------	-------

Stored Usable Fluid Required: **60.72 gallons**

Accumulator Bottles = $60.72 / 5.0 = 12.15$ **Required bottles = 13**

Nota: Regulations of various countries and some oil companies may have specific requirements. These calculations are for example only.

BOP CONTROL SYSTEM
Example of calculations for fluid capacity
(IADC Drilling Manual, 11th edition, 1992) (continued)

III APPLICATION OF BOYLE'S LAW FOR CALCULATING STORED USABLE FLUID IN A SUBSEA ACCUMULATOR BOTTLES

$$P_1 \times V_1 = P_2 \times V_2$$

In subsea, the pre-charge pressure must be added with the seawater hydrostatic pressure :
 seawater hydrostatic gradient = 0.445 psi per foot

Application in 3000 feet of water:

Accumulator capacity: 10 gallons (V₁)

Accumulator bottle pre-charge in 3000 feet of water:
 $1000 + 3000 \times 0.445 = 2335$ psi (P₁)

Minimum pressure required to operate BOP in 3000 feet of water:
 $2335 + 200 = 2535$ psi (P₂)

Maximum pressure in the bottle in 3000 feet of water:
 $2335 + 2000 = 4335$ psi (P₃)

Usable fluid forced out of the bottle from 4335 psi to 2535 psi: V₂ - V₃

$$\begin{aligned} V_2 &= P_1 \times V_1 / P_2 & V_3 &= P_1 \times V_1 / P_3 \\ V_2 &= 2335 \times 10 / 2535 & V_3 &= 2335 \times 10 / 4335 \\ V_2 &= 9.2 \text{ gallons} & V_3 &= 5.4 \text{ gallons.} \end{aligned}$$

Usable fluid: 3.8 gallons

IV SIZING ACCUMULATOR SYSTEM FOR SUBSEA BOP

Example of BOP stack:

Hydril GK 13 5/8-5000 (L 33)

Three U-13 5/8-10000 (two rams and one shear ram) (L 20)

Annular gallons to close: 17.98

Annular gallons to open: 14.16

Two rams @ 5.8 gal. each to close: 11.6

Two rams @ 5.4 gal. each to open: 10.8

One shear ram to close: 10.9

One shear ram to open: 10.5

Total: 75.94

Plus 50% Safety Factor: 37.97

Stored Usable Fluid Required: **113.91 gallons**

BOP CONTROL SYSTEM
Example of calculations for fluid capacity
(IADC Drilling Manual, 11th edition, 1992) (continued)











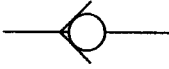

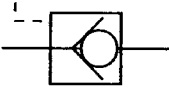

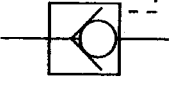
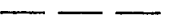

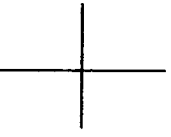
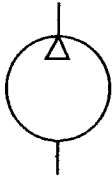
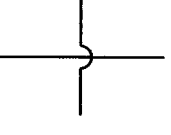
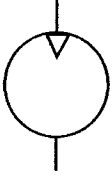

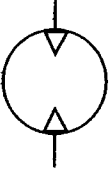
At least the capacity to close the annular and one ram will be mounted **subsea**:

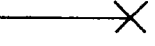
$$\begin{aligned} \text{Subsea capacity} &= 17.98 + 11.6 &= 29.58 \text{ gallons} \\ \text{Subsea bottles} &= 29.58/3.8 &= 7.78 \text{ or } \mathbf{8} \text{ bottles} \\ \text{Surface capacity} &= 113.91 - 29.58 &= 84.33 \text{ gallons} \\ \text{Surface bottles} &= 84.33/5.0 &= 16.87 \text{ or } \mathbf{17} \text{ bottles} \end{aligned}$$



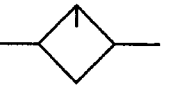

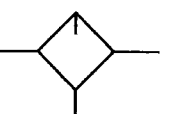
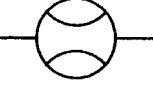
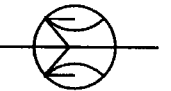

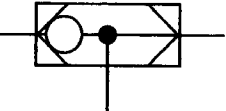



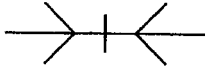
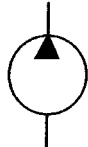
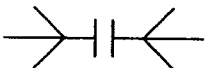

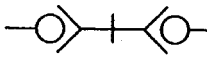
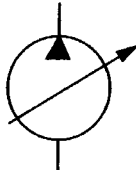
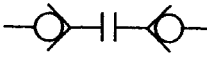
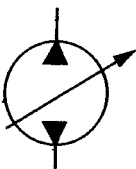
Nota: These subsea bottles must be of 5000 psi Working Pressure. Regulations of various countries and some oil companies may have specific requirements. These calculations are for example only.

SCHEMATIC SYMBOLS FOR FLUID POWER DIAGRAMS

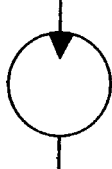
(Based on ANSI Y. 32.10)
(API Spec 16D, 1st edition, March 1, 1993)

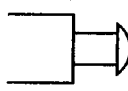
	: Main lines		: Check valve (free flow is from left to right)
	: Hydraulic lines		: Pilot operated check valve (pilot to open)
	: Pneumatic lines		: Pilot operated check valve (pilot to close)
	: Pilot lines (dashes)		
	: Drain lines (dotted)		
	: Lines crossing (not connected)		: Compressor, fixed displacement, pneumatic
	: Lines crossing (alternate)		: Motor, uni-directional, pneumatic
	: Lines connected		: Motor, bi-directional, pneumatic
	: Connected to reservoir (above fluid level)		
	: Connected to reservoir (below fluid level)		
	: Plugged port		: Internal combustion engine
	: Filter or strainer		: Pressure gauge
	: Lubricator without drain		: Temperature gauge
	: Lubricator with drain		: Flow rate flowmeter
	: Totalizing flow meter		: Receiver, air or gas
	: Shuttle valve		

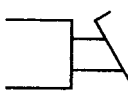
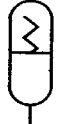
SCHEMATIC SYMBOLS FOR FLUID POWER DIAGRAMS
(Based on ANSI Y. 32.10)
(API Spec 16D, 1st edition, March 1, 1993)
 (continued)

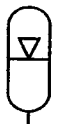
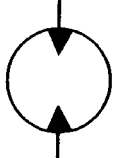
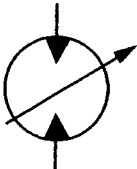
	: Quick disconnect, connected		: Pump, hydraulic, uni-directional, fixed displacement
	: Quick disconnect, disconnected		: Pump, hydraulic, bi-directional, fixed displacement
	: Quick disconnect, with check valve, connected		: Variable displacement hydraulic pump, uni-directional
	: Quick disconnect, with check valve, disconnected		: Variable displacement bi-directional hydraulic pump
	: Manual shut off valve, normally open		: Electric motor
	: Manual shut off valve, normally closed		: Hydraulic motor fixed displacement, uni-directional
	: Orifice, fixed		: Push button operator
	: Adjustable orifice		: Foot pedal operator
	: Accumulator, spring loaded		: Mechanical operator
	: Accumulator, gas charged		
	: Hydraulic motor, fixed displacement bi-directional		
	: Hydraulic motor, variable displacement uni-directional		

SCHEMATIC SYMBOLS FOR FLUID POWER DIAGRAMS

(Based on ANSI Y. 32.10)
(API Spec 16D, 1st edition, March 1, 1993)
(continued)

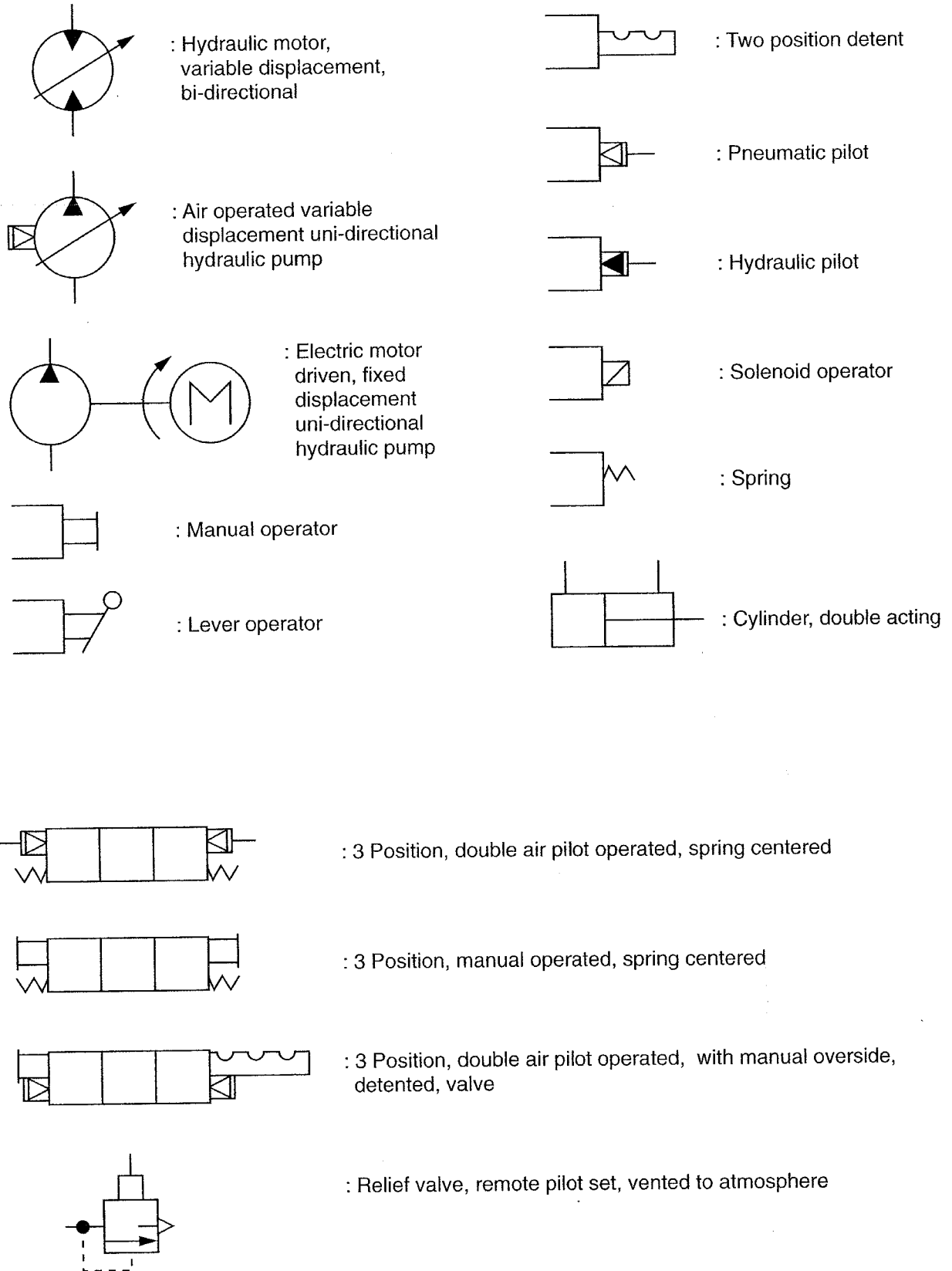

SCHEMATIC SYMBOLS FOR FLUID POWER DIAGRAMS
(Based on ANSI Y. 32.10)
(API Spec 16D, 1st edition, March 1, 1993)
(continued)

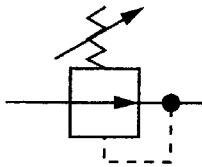

: Regulator, manual set, non-relieving

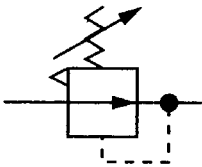

: Regulator, manual set, relieving type (fluid vented to ambient)

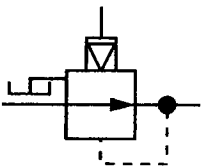

: Regulator, air pilot operated, relieving (fluid vent connected to reservoir)

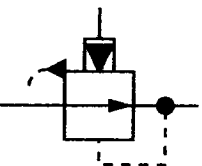

: Regulator, hydraulic pilot operated, relieving (fluid vented to ambient)

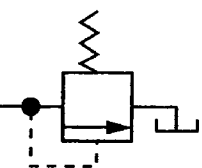

: Relief valve, non adjustable (vent connected to reservoir)

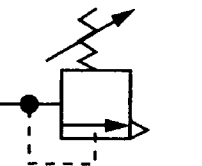

: Relief valve, adjustable (vented to ambient)

SCHEMATIC SYMBOLS FOR FLUID POWER DIAGRAMS
(Based on ANSI Y. 32.10)
(API Spec 16D, 1st edition, March 1, 1993)
 (continued)

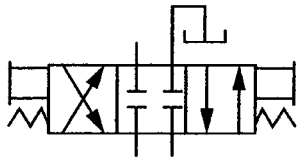

: 4 way, 3 position, manual operated, spring centered,
center position, all ports blocked

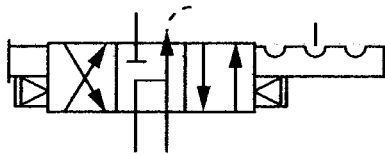

: 4 way, 3 position, pilot cylinder operated with manual
override, detented, pressure blocked, cylinders
vented to ambient in the center position, valve

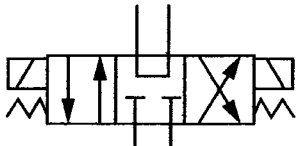

: 4 way, 3 position, solenoid operated, spring centered,
pressure connected to return, cylinder ports blocked, valve

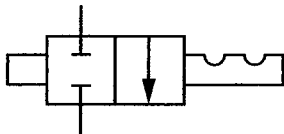

: 2 way manual operated, detented valve
(shown in the closed position)

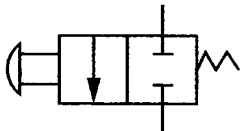

: 2 way, push button operated, spring return,
normally close valve

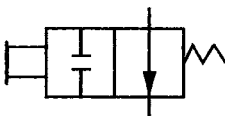

: 2 way, manual operated, spring return,
normally open valve

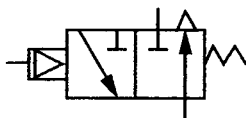

: 3 way, pneumatic pilot operated, spring return,
normally closed valve (fluid vents to ambient)

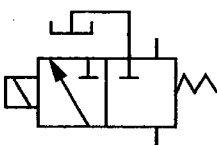

: 3 way solenoid operated, spring return,
normally open valve (fluid vent is connected to reservoir)

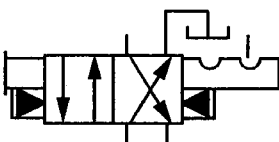

: 4 way, two position, hydraulic pilot operated with manual
override, detented valve (fluid vent is connected to reservoir)

M

geology

Tertiary and quaternary cenozoic eras.....	M1
Secondary Mesozoic era.....	M2
Primary paleozoic era.....	M3
Table of grain size classes.....	M4
Representation of sediments.....	M5-M6
Exploration symbols in drilling.....	M7
Gases present in drilling muds and detected by chromatography.....	M8
Physical properties of H ₂ S.....	M9
Pore pressure.....	M10
Fracturing gradient and leak off test.....	M11
Abbreviations used in wireline logging – Halliburton.....	M12-M13
Abbreviations used in wireline logging – Schlumberger.....	M14-M15
Abbreviations used in wireline logging - Western Atlas....	M16-M17

TERTIARY AND QUATERNARY CENOZOIC ERAS

Cosuna	Odin	Systems		Series		STAGES		AGES		Orogenic phases	
		Period	Epoch	Standard classification	Sub-stages and/or local equivalents						
Age (Ma)											
0.01		QUATERNARY	Holocene	Versilian	Flandrian					Pasadenian	
			PLEISTOCENE	Upper	Tyrrhenian Milazzian Sicilian						
				Lr.	Emilian Calabrian						
		NEOGENE (Nummulitic)	Pliocene	Astian Plaisancian Zanclean Tabianian		Villafranchian					Walachian Rhodanian Attic
				MIOCENE	Upper	Messinian Tortonian			Pontian Meotian Sarmatian		
			Mid		Serravallian Langhian	Helvetian					
			Lower		Burdigalian Aquitanian	Vindobodian					
			PALEOGENE	Oligocene	Chattian Rupelian Stampian		Sannoisian				Lepontine
		EOCENE		Upper	Bartonian Priabonian	Ludian Marinesian Auversian	Lattorfian Tongrian				
				Mid	Lutetian	Ledian		Biarritzian			
				Lr.	Ypresian	Cuisian Sparnacian		Ilerdian			
Paleocene	Thanetian Montian Danian							Laramide			
67	65										

ALPINE

From J. Guillemot, *Elements of Geology*, Éditions Technip, Paris 1991.

SECONDARY MESOZOIC ERA

Age (Ma)	Cosuna	Odin	Systems	Series	STAGES		AGES		Orogenic phases	
					Standard classification	Sub-stages and/or local equivalents				
			Period	Epoch						
100 95			CRETACEOUS	Upper	Senonian	Maestrichtian	Aturian	Rognacian		eo-Alpine
						Campanian		Begudian		
						Santonian Coniacian		Fuvelian Valdonian		
					Turonian	Emscherian				
					Cenomanian	Provencian Ligerian		Angoumian Salmurian		
					Lower	Albanian	Vraconian Clansayesian		Gault	
				Aptian		Gargasian Bedoulian				
				Barremian						
				Hauterivian Valanginian		Neocomian	Wealden			
				140 130				Berriasian		
160 158			JURASSIC	Upper	Malm	Portlandian	Tithonian	Volgian		ALPINE
						Kimmeridgian		Sequanian		
						Oxfordian		Rauracian Argovian		
				Lower	Dogger	Callovian Bathonian Bajocian Aalenian				
						Toarcian				
200 204			JURASSIC	Lower	Lias	Pliensbachian	Charmoutian	Domerian Carixian		
						Sinemurian	Lotharingian			
						Hettangian				
						Trias	Rhaetic Norian Carnian Ladinian Anisian Scythian			
		Keuper	Early Cimmerian							
		Muschelkalk	Palatinian							
		Wirglorian Werferian		Bundsandstein						
250 245										

From J. Guillemot, *Elements of Geology*, Éditions Technip, Paris 1991.

PRIMARY PALEOZOIC ERA

Cosuna	Odin	Systems		Series	STAGES		AGES	Orogenic phases	
		Period	Epoch		Standard classification	Sub-stages and/or local equivalents			
290	290	PERMIAN	Upper	Tatarian Kazanian	Thuringian	Zechstein	Saalian	VARISCAN	
			Lower	Kungurian Artinskian Sakmarian	Saxonian Autunian	Rotliegende	Asturian		
330	360	CARBONI-FEROUS	Upper	Stephanian Westphalian Namurian	Ouralian Moscovian Bashkirian	Pennsylvanian	Sudetic		
			Lower	Dinantian	Visean Tournaisian	Mississippian	Bretonic		
405	400	DEVONIAN	Upper	Famennian	Strunian	Old Red Sandstones	eo-Hercinian		
				Frasnian					
			Middle	Givetian Couvinian	Eifelian				
425	418	SILURIAN	Upper	Pridoli Ludlow Wenlock			Ardennes		
			Lower	Llandovery					
500	495	ORDO-VICIAN	Upper	Ashgill Caradoc			Taconic		
			Middle	Llandeilo Llanvirn					
			Lower	Arenig Tremadoc					
570	530	CAMBRIAN		Postdamian Acadian Georgian			Sardinian		
2500	2000	PRECAMBRIAN	Protero-zoic	Brioverian	Algonkian	Infracambrian	Grenvillian		
				Pentevrian		Vendian Riphaean			
			3000		ARCHAEAN				
4000									

TABLE OF GRAIN SIZE CLASSES

Φ scale		10	9	8	7	6	5	4	3	2	1	0	-1	-2	-3	-4
Fractions of mm				$\frac{1}{256}$	$\frac{1}{128}$	$\frac{1}{64}$	$\frac{1}{32}$	$\frac{1}{16}$	$\frac{1}{8}$	$\frac{1}{4}$	$\frac{1}{2}$					
		1 μ m	2	4	8	16	31	62.5	125	250	500	1 mm	2	4	8	16
Lutites						Arenites					Rudites					
Loose	Clay	Silt	Sands					Granules	Gravel	Pebbles						
			Very fine	Fine	Medium	Coarse	Very coarse									
Consolidated	Mudstones	Siltstones	Sandstones					Conglomerates								

Sizes are expressed in millimeters or microns, in fractions of millimeters and in Φ units. ($\Phi = -\log_2$ of diameter in millimeters).

From J. Guillemot, *Elements of Geology*, Éditions Technip, Paris 1991.

REPRESENTATION OF SEDIMENTS (1)

1 PREDOMINANTLY SHALE ROCKS

1.1 One-component rocks

 Clay, shale

1.2 Two-component rocks

 ALS Slightly sandy shale

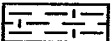
 ACL Calcareous shale

 ASB Sandy shale

 ADL Dolomitic shale

 ASL Silicified claystone

2 PREDOMINANTLY SILICA ROCKS

2.1 One-component rocks

Slt  SLT Silt

 GFN Fine to very fine sandstone

 SFN Fine to very fine sand

 GMN Medium sandstone

 SMN Medium sand

 GGR Coarse to very coarse sandstone

 SGR Coarse to very coarse sand

 QTZ Quartzite

Sti  STI Siltstone

 SLX Chert

2.2 Two-component rocks

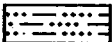
 STA Argillaceous silt

 GDL Dolomitic sandstone

 GAR Argillaceous sandstone

 GMO Asphaltic or bituminous sandstone

 GCL Calcareous sandstone

 GCQ Shelly sandstone

3 PREDOMINANTLY CARBONATE ROCKS

3.1 Predominantly limestone rocks

3.1.1 One-component rocks

 CLC Limestone

 CCN Reefal limestone

 CRA Chalk

 CCQ Coquina

Coo  COO Oolitic limestone

M 6

REPRESENTATION OF SEDIMENTS (continued)

3.1.2 Two-component rocks

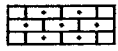

CSB Sandy limestone

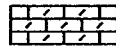

CDL Dolomitic limestone



CAR Argillaceous limestone

3.2 Predominantly dolomitic rocks

3.2.1 One-component rocks

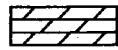

DLM Dolomite

3.2.2 Two-component rocks

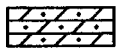

DSB Sandy dolomite

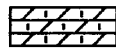

DCL Calcareous dolomite



DAR Argillaceous dolomite

4 ROCKS WITHOUT PREDOMINANT COMPONENT

Two-component rocks

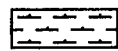

RAC Clay, limestone rock
(Marlstone, not recommended)

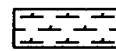

RAD Clay, dolomite rock

5 EVAPORITES

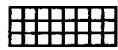

EVP Evaporite



ANH Anhydrite



HLT Halite

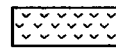

GPS Gypsum

6 CONGLOMERATES (one or more components)

blc

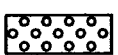

CG

Monogenic conglomerate
(cobbles to boulders)

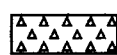

BRM

Monogenic breccia

7 OTHER TYPE OF SEDIMENTARY ROCK



CHR Coal or lignite

8 ERUPTIVE AND METAMORPHIC ROCKS



RVI Undifferentiated volcanics



MTM Metamorphic rocks

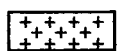

ACI Acid rocks (granite)



BSL Basalt

9 MINERALS

x Glaucinite

■ Pyrite

EXPLORATION SYMBOLS IN DRILLING

SHOWS

A. Shows from cuttings and cores

Oil in mass	●
Oil in fractures	◻
Emanation of gas	☀
Direct fluorescence of mass (pale +, bright ++, very bright +++)	▲ +
Direct fluorescence on fractures	◻ +
Fluorescence on extraction	△
Asphalt, bitumen	●
Water (with indication of salinity in g/l)	⊕ 35
Odor (x) ¹	◇ x

B. In drilling mud

Oil	● M
Direct fluorescence (pale +, bright ++, very bright +++)	▲ M ₊
Gas (y, z,...) ²	☀ _y ^M
Gasoline, condensate	☀ ^M
Sulfides dissolved in mud	S--M
Losses	↘
Gains	↗

(1) x = hydrocarbons, H₂S, etc.

(2) y, z, ... = hydrocarbons, CO₂, N₂, H₂S, etc.

GASES PRESENT IN DRILLING MUDS AND DETECTED BY CHROMATOGRAPHY (1)

Gas	Formula	Boiling point (°C) (3)	Density (in relation to air) (4)
Helium	He	- 268.9	0.138
Hydrogen	H ₂	- 252.9	0.070
Nitrogen	N ₂	- 195.8	0.967
Methane	CH ₄ (C ₁)	- 161.5	0.555
Carbon dioxide	CO ₂	- 78.2 (2)	1.527
Ethane	C ₂ H ₆ (C ₂)	- 88.6	1.047
Hydrogen sulfide	H ₂ S	- 60.3	1.187
Propane	C ₃ H ₈ (C ₃)	- 42.1	1.551
Isobutane	C ₄ H ₁₀ (<i>i</i> -C ₄)	- 11.8	2.075
<i>n</i> -butane	C ₄ H ₁₀ (<i>n</i> -C ₄)	- 0.5	2.081
Isopentane	C ₅ H ₁₂ (<i>i</i> -C ₅)	27.8	2.626
<i>n</i> -pentane	C ₅ H ₁₂ (<i>n</i> -C ₅)	36.1	2.643
-	(C ₆ ⁺)	> 50	-

(1) Retention time in the chromatograph is inversely proportional to the boiling point (except for CO₂). The detection of a gas depends on the type of chromatographic column and on its concentration.

(2) Sublimation point.

(3) At 101.325 kPa (abs.)

(4) At 101.325 kPa (abs.) and 15°C

Reference: J.F. Gravier. *Propriétés des fluides de gisements*. Éditions Technip, Paris. 1986.

PHYSICAL PROPERTIES OF H₂S

- Color:** Colorless
- Odor:** Rotten eggs at low concentration, odorless at high concentration
- Density:** 1.189 **hence heavier than air**
- Solubility:** Four volumes of gas are soluble in one volume of water
- Flammability:** It forms an explosive mixture with air when it occupies between 4.3 and 46% of this mixture.
It burns with a blue flame and its combustion produces a very irritating gas: sulfur dioxide (SO₂).

H₂S is a toxic gas

For an H₂S content of:

- 1 ppm = 0.0001% : detection by smell (rotten eggs)
- 10 ppm = 0.001% : concentration limit for work lasting 8 hours (1)

USE YOUR BREATHING APPARATUS ABOVE THIS CONCENTRATION

- 100 ppm = 0.01% : loss of sense of smell in 3 to 15 min
- 200 ppm = 0.02% : sense of smell paralyzed
- 500 ppm = 0.05% : loss of balance and consciousness breathing difficulty within 2 to 15 min
- 700 ppm = 0.07% : fainting; respiratory arrest
- 1000 ppm = 0.1% : **mortal concentration** if artificial respiration is not practised

(1) 10 or 20 ppm depending on local regulations.

From publication of the *French Oil and Gas Industry Association*, Technical Committee.

PORE PRESSURE

The main techniques for evaluating the pore pressure are based on the difference between the measured or calculated value of a parameter (resistivity, shale density, standard rate of penetration, etc.) and the extrapolated value based on the normal trend.

One of the most widely used parameter is the rate of penetration.

The "d exponent" method of Jordan and Shirley

The *d* exponent is only significant in shale and with milled tooth bits (rock bits).

The interpretation is based on the assumption of undercompacted shales:

$$v_a = KN \left(\frac{WOB}{D} \right)^d$$

where:

- v_a = rate of penetration (**m/h** or ft/h)
- WOB = weight on bit (**t** or lb)
- N = speed of rotation of the bit (**rpm**)
- D = bit diameter (**in**)
- K = proportionality factor
- d = *d* exponent

$$d = \frac{\log \frac{v_a}{N}}{\log \frac{WOB}{D}}$$

$$d = \frac{\log \frac{v_a}{60N}}{\log \frac{12WOB}{10^6 D}}$$

American units

$$d = \frac{1.26 - \log \frac{v_a}{N}}{1.58 - \log \frac{WOB}{D}}$$

Combined units (in bold above)

$$P_f = P_{fn} \frac{d_n}{d_o}$$

- P_f = observed pore pressure
- P_{fn} = normal pore pressure at depth Z
- d_n = *d* exponent extrapolated on the normal curve
- d_o = *d* exponent calculated at the same depth

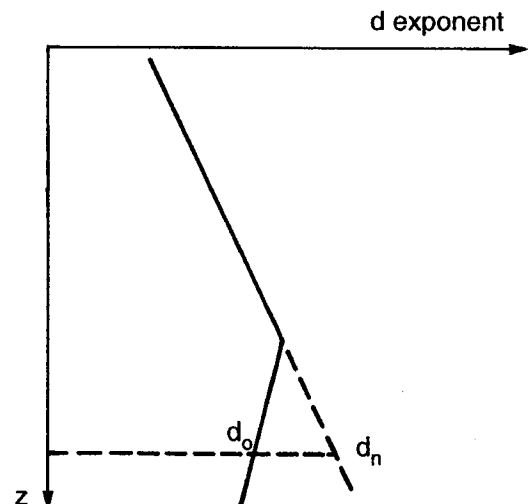

FRACTURING GRADIENT AND LEAK OFF TEST

EATON FORMULA

$$P_{frac} = P_f + \frac{\mu}{1-\mu} (S - P_f)$$

- P_{frac} = fracturing pressure
- P_f = pore pressure
- S = overburden pressure (weight of formations)
- μ = Poisson's ratio (0.25 to 0.50)

LEAK OFF TEST

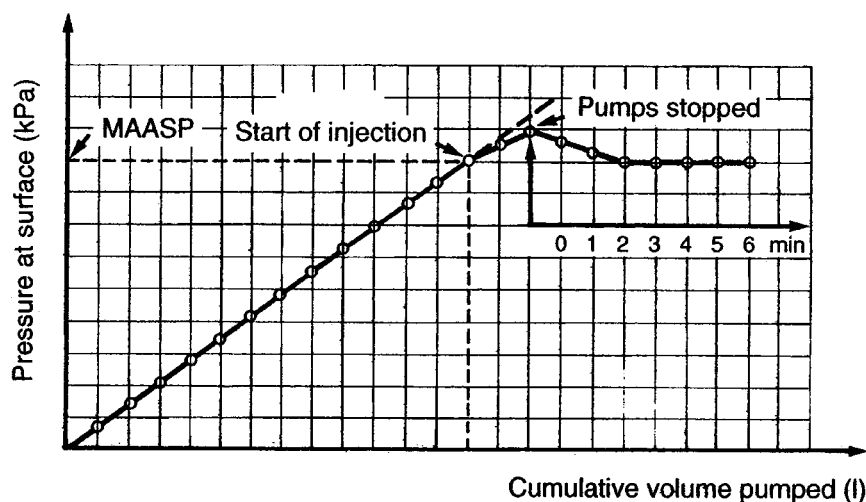

$$P_{frac} = MAASP + 9.81 Z_s d \qquad d_{frac} = \frac{P_{frac}}{9.81 Z_s}$$

where:

- P_{frac} = fracturing pressure (kPa)
- MAASP = pressure at start of injection point (kPa)
- d_{frac} = fracture density (kg/l)
- d = mud density in the well during leak off test (kg/l)
- Z_s = depth of weak point (or shoe) (m)

MUD COMPRESSIBILITY

Water Base Mud (WBM)	Oil Base Mud (OBM)	Base Oil
$0.45 \cdot 10^{-6} \text{ kPa}^{-1}$	$0.80 \cdot 10^{-6} \text{ kPa}^{-1}$	$0.70 \cdot 10^{-6} \text{ kPa}^{-1}$
$0.30 \cdot 10^{-5} \text{ psi}^{-1}$	$0.55 \cdot 10^{-5} \text{ psi}^{-1}$	$0.47 \cdot 10^{-5} \text{ psi}^{-1}$
0.45 10^{-2} liters/bar per m^3	0.80 10^{-2} liters/bar per m^3	0.70 10^{-2} liters/bar per m^3
4.5 liters per bar for 100 m^3	8 liters per bar for 100 m^3	7 liters per bar for 100 m^3
4.5 liters per m^3 for 100 bar	8 liters per m^3 for 100 bar	7 liters per m^3 for 100 bar
4.5 liters per MPa for 10 m^3	8 liters per MPa for 100 m^3	7 liters per MPa for 10 m^3
4.5 liters per m^3 for 10 MPa	8 liters per m^3 for 100 MPa	7 liters per m^3 for 10 MPa
3 liters per m^3 for 1000 psi	5.5 liters per m^3 for 1000 psi	4.7 liters per m^3 for 1000 psi
0.125 gal per bbl for 1000 psi	0.229 gal per bbl for 1000 psi	0.192 gal per bbl for 1000 psi

ABBREVIATIONS USED IN WIRELINE LOGGING

Halliburton

Resistivity		Diplog and Caliper	
DIL	Go Dual Induction	CAL_x	Caliper x
DIND	Dits Dual Induction	FEDOLD	Four Arm Dipmeter
DLL	Standard Dual Laterolog	FIAC	Four Independant Arm Caliper
HDIL	Hostile Dual Induction	HECT	Hostile Four Arm caliper
HEDL	Hostile Env. Dual Laterolog	MACT	Multi-Arm Caliper Tool
LL3	Laterolog 3	MSFCAL	MSFL Caliper
MICLOG	Microlog	SED	Six Electrode Dipmeter (DITS)
MSFL	Micro-Spherically Focused	XYCA	Analog XY Caliper
Radioactivity		Formation Sampling	
CDL	Compensated Density Log	PQ_PL	Pressure -(Petro-Quartz)
CNT	Compensated Neutron Log	SFT	Sequential Formation Tester
DSEN	Dual Spacing Epithermal Neutron	SFT4	SFT4 Petro Quartz
EVRSDL	Spectral Density (EVR)	Production Logging	
GAMMA	Gamma Ray Tool		
GR_xyz	Natural Gamma + xyz	BATS	Borehole Audio Tracer Survey
HDSN	Hostile Dual Spaced Neutron	CEN_x	Production Logging Centralizer
HGNC	Hostile CCL/Gamma/Neutron	CENT	Bottom Centralizer in FWST
HSDL	Hostile Spectral Density Inst.	COP_MP	Pressure [Petro-Quartz]
RMT	Reservoir Monitor Tool	FDL_TT	Flow Diverter - TTTC
SDL	Spectral Density	FLD_PL	Fluid Density
SGR	Spectral Gamma Ray	FLTT	Fluid travel Tool
SLD	Spectral Litho-Density	FMS_MP	High Sensitive Flowmeter
TMD	Thermal Multigate Decay	GHT	Gas Holdup Mux
TMDL	Thermal Multigate Decay Lith.	H_CENT	Hostile Centralizer
TRAC_x	Tracer Scan - x	HMR_MC	HMR Quartz Pressure Tool
Acoustic		HYD_xy	Center Sample Hydrometer
BCS	Compensated Sonic	M_FLOW	Sondex Fullbore Flowmeter
CAST	Acoustic Scanning Tool	M_GRAD	Sondex Gradiometer
CBL	Cement Bond Log	QPG_MP	Quartz Pressure Tool
FWS	Full Wave Sonic	SPIN	DC Spinner
HFWSA	Hostile Sonic - Full Wave (A)	TEMPDC	Temperature
		TPH_PL	Temperature High Resolution

ABBREVIATIONS USED IN WIRELINE LOGGING

Halliburton (continued)

Pipe Evaluation		Pipe Recovery	
		CIC CIT PIT PIT8	Casing Inspection Caliper Casing Inspection Tool DITS Pipe Inspection Tool Pipe Inspection Tool (8 pad)
Plug Setting and Mechanical			
			Perforating
		CCL M157 M187	Casing Collar Locator M157 Gamma Perforator M187 Gamma Perforator
Auxiliary			
BRID DTD DTEN FLEX HDTD	Cable Electrode Bridle Downhole Tension Device Differential Tension Flex joint Hostile Downhole Tension Sub		

ABBREVIATIONS USED IN WIRELINE LOGGING

Schlumberger

Resistivity		Radioactivity	
AIT	Array Induction Imager Tool	PGT	Compensated Density Tool
ALAT	Azimuthal Laterolog	PNT	Sidewall Neutron Tool (SNP)
ARC	Array Resistivity Compensated Tool (Anadrill)	RST	Reservoir Saturation Tool
CDR	Compensated Dual Resistivity Tool (Anadrill)	SGT	Scintillation Gamma Ray Tool
DIT	Dual Induction Tool (SFL or LL8)	SLDT	Slimhole Litho-Density Tool
DLT	Dual Laterolog Tool	SSGT	Scintillation Gama Ray Tool
DST	Dual Laterolog Tool with SRT (MSFL)	SWT	Water Saturation Tool
ES	Electrical Survey Tool	TDT	Thermal Decay Time Tool
HALS	HILT Azimuthal Laterolog Sonde	Acoustic	
IRT	Induction Logging Tool (w/o SN)		
ISF	Induction Spherical Focused Log	ASMT	Acoustic Sonde Measuring Tool
LL3	Laterolog 3 Sonde	AST	Acoustic Scanner Tool
LL7	Laterolog 7 Sonde	BHTV	Borehole Televiewer
MCFL	HILT Micro-Cylindrical Focused Log Device	CBT	Cement Bond Tool
MLL	Microlaterolog Tool	CET	Cement Evaluation Tool
MLT	Microlog Tool	CMT	Circumferential Microsonic Tool
MPT	Microlog Proximity Tool (PL)	CSAT	Combined Seismic Acquisition Tool
RAB	Azimuthal Resistivity At the Bit Tool (Anadrill)	CWRT	Cross Well Receiver Tool
SRT	Micro Spherical Focused Resistivity Tool	DSA	Downhole Seismic Array
Radioactivity		DSL	Digitizing Sonic Logging Tool
		DSST	Dipole shear Sonic Imager Tool
AACT	Aluminium Activation Clay Tool	DWST	Digital Waveform Sonic Tool
ADN	Azimuthal Density Neutron Tool (Anadrill)	ISONIC	Sonic Tool (Anadrill)
AGS	Aluminium Gamma Ray Spectroscopy Sonde	QSST	Quick Shot Seismic Tool
APS	Accelerator Porosity Sonde	SAT	Seismic Acquisition Tool
CDN	Neutron Density Sonde (Anadrill)	SDT	Sonic Digital Tool (AS, BHC, DDBHC, CBL)
CGRS	Compact Gamma Ray Sonde	SLT	Sonic Logging Tool (BHC, DDBHC, CBL)
CNT	Compensated Neutron Tool	SSLT	Slim Sonic Logging Tool
ECS	Elemental Capture Spectroscopy Cartridge	UBI	Ultrasonic Borehole Imager
FGT	Formation Gamma Ray Tool	UCI	Ultrasonic Corrosion Imager
FSMT	Formation Subsidence Monitoring Tool	USIT	Ultrasonic Imaging Tool
GFT	Formation Tester Gamma Ray Tool	WST	Seismic Acquisition Tool
GNT	Gamma Neutron tool	Diplog and Caliper	
GPT	Gamma Ray Perforating Tool		
GRA	Geochemical Reservoir Analyzer	CALI	Generalized Caliper
GRT	Gamma Ray Tool	ECD	Eccentred Caliper Device
GST	Gamma Spectroscopy Tool	EDAC	Eccentred Dual Axis Caliper
HLDT	Hostile Environment Litho Density Tool	HDT	High Resolution Dipmeter Tool
HNGT	Hostile Natural Gamma Ray Spectroscopy Tool	FBST	Full Bore Scanner Tool (FMI)
HSGT	Hostile Environment Gamma Ray Tool	MCD	Mechanical Caliper Device
LDS	Litho Density Tool (IPLT)	MEST	Micro-Electrical Scanner Tool (FMS)
LDT	Litho Density Tool	OBDT	Oil Base Mud Dipmeter Tool
MIST	Multiple Isotope Spectroscopy Tool	PCD	Powered Caliper Device
MSGT	Scintillation Gamma Ray Tool	SHDT	Stratigraphic High Res. Dipmeter Tool
NDT	Neutron Depth Tool	SPCS	Slim Powered Caliper Sonde
NFD	Nuclear Fluid Density Tool	TCS	Through Tubing Caliper Sonde
NGT	Natural Gamma Ray Spectroscopy Tool	VCD	Caliper Device
NPLT	Nuclear Porosity Lithology Tool (IPLT)		
PGGT	Powered Gun Gamma Ray Tool		

ABBREVIATIONS USED IN WIRELINE LOGGING

Schlumberger (continued)

Formation Sampling		Pipe evaluation	
CST	Core Sidewall Takeri	CIT	Casing inspection Tool
FIT	Formation Interval Tester	CPET	Corrosion Protection Evaluation Tool
MDT	Modular Formation Dynamics Tester	ETT	Electromagnetic Thickness Tool
MSCT	Mechanical Sidewall Coring Tool	FTGT	Tubing Geometry Tool
PST	Production Fluid Sampler Tool	MFCT	Multi-Finger Caliper Tool
RFT	Repeat Formation Tester	PAT	Pipe Analysis Tool
		PHAT	Pit and Hole Analysis Tool
Production Logging		Plug Setting and Mechanical	
CFS	Continuous Flowmeter Sonde	BO	Back-off Tool
DEFT	Digital Entry and Fluid Imager Tool	CCL	Casing Anomaly Locator
EFM	Electrical Flowmeter Tool (Flopetrol-John.)	CERT	Correlatable Electromagnetic Recovery Tool
FBDS	Full Bore Directional Spinner Flowmeter Sonde	FPIT	Free Point Indicator Tool
FBS	Full Bore Spinner Flowmeter Sonde	MPBT	Mechanical Plugback Tool
GMS	Gradiomanometer Sonde	SPPT	Production Packer Tool
HCFT	Flowmeter Sonde		
HTT	High Resolution Thermometer Tool	Auxiliary	
HUM	Hold Up Meter	ACTS	Auxiliary Compression Tension Sub
LEE_FM	Flowmeter manufactured by Lee Tools	AMS	Auxiliary Measurement Sonde
LIFT	Local Impedance Flowmeter Tool	EMS	Environment Measurement Sonde
PBFT	Petal Basket Flowmeter Tool	MPD	Magnetic Positioning Device
RCT	Flowmeter Transmitter (Rotron type)	NOSE	Nose Orienting Scanning Equipment
SCTT	Sidewall Contact Temperature Tool	TTG	Through Tubing Guide
SVFS	Slim Hole Vortex Flowmeter Sonde	Perforating	
TEMP	Temperature	GUN	Perforating Gun
TMT	Temperature Manometer Tool	PGGT	Powered Gun Gamma Ray Tool

ABBREVIATIONS USED IN WIRELINE LOGGING

Western Atlas

Resistivity		Diplog® and Caliper	
DEL2	Dielectric Log 200MHz	2CAL	2-Arm Caliper Log
DIFL	Dual Induction-Focused Log	3CAL	3-Arm Caliper Log
DLL	Dual Laterolog	4CAL	4-Arm Caliper Log
DPIL SM	Dual Phase Induction Log	DIP	High Resolution 4-Arm Diplog
IEL	Induction Electrolog	HDIP SM	Hexagonal Diplog SM
ML	Minilog®	Formation Sampling	
MLL	Micro Laterolog		
TBRT®	Thin-Bed Resistivity	CHFT	Cased Hole Formation Tester
Radioactivity		FMT	Formation Multi-Tester
		FQPG	Fast Response Quartz Pressure Gauge
CDL	Compensated Densilog SM	QPG	Quartz Pressure Gauge
CN	Compensated Neutron Log	RCI SM	Reservoir Characterization Instrument
GR	Gamma Ray Log	RCOR SM	Rotary Sidewall Coring Tool
HYDL	Hydrolog SM	SWC	Sidewall Corgun
MRIL®	Magnetic Resonance Imaging Log	VPC	VPC Formation Multi-Tester
MSI	Multiparameter Spectroscopy Instrument	Production Logging	
PDK	PDK-100®		
PFC	Perforation-Formation-Collar Log	CCL	Casing Collar Locator
PRSM	PRISM® Log	DWP	Downhole Wireline Packoff
SL	Spectralog®	FCON	Fluid Conductivity Log
ZDL	Compensated Z-Densilog SM	FDDP	Differential Pressure Fluid Density
Acoustic		FDN	Nuclear Fluid Density
		FMBK	Basket Flowmeter
AC	BHC Acoustilog	FMCS	Continuous Spinner Flowmeter
ACL	Long-Spaced BHC Acoustilog SM	FMFI	Folding Impeller Flowmeter
BAL®	Bond Attenuation Log	FQPG	Fast Response Quartz Pressure Gauge
CBIL SM	Circumferential Borehole Imaging Log	NFL	Nuclear Flolog SM
CBL	Acoustic Cement Bond Log	PHT	Photon Log
DAC SM	Digital Array Acoustilog SM	QPG	Quartz Pressure Gauge
DAL	Digital Acoustilog	SON	Sonar
DRB SM	Dual Receiver Bond Log	SPG	Strain Pressure Gauge
MAC SM	Multiple Array Acoustilog SM	SRPL	Surface Recorded Pressure Log
SBT SM	Segmented Bond Tool	SWAT	Swing-Arm Tracerlog
SRB	Single Receiver Bond Log	TBFS	Through-Tubing Borehole Fluid Sampler
		TCAL	Through-Tubing (X-Y) Caliper
		TEMP	Differential Temperature
		TRL	Tracerlog
		VIBR	Vibrator
		WHI	Water Holdup Indicator

ABBREVIATIONS USED IN WIRELINE LOGGING

Western Atlas (continued)

Pipe Evaluation		Pipe Recovery	
CPP	Casing Potential Profile	BHJ	Bottomhole Junk Shot
DMAG	Digital Magnelog SM	BO	String Shot-Back Off
DVRT	Digital Vertilog SM	CC	Chemical Cutters
MAG	Magnelog SM	FG	Feeler Gauge
MFC	Multi-Finger Caliper	FPST	Spring-Tector SM Freepoint Indicator
MVRT	Multichannel Vertilog SM	FPTM	Tri-Mag Freepoint Indicator
VRT	Vertilog [®]	HCS	Hydraulic Cleanout Service
VTLN	Vertiline SM	JCS	Jet Cutters
Plug Setting and Mechanical		MST	Metal Severing Tool
BP	Bridge Plug	PRL	Pipe Recovery Log
CRET	Cement Retainer	SSH	Surface Shot
DB	Dump Bailer	Perforating	
JCGR	Junk Catcher Gauge Ring	AJ	Alpha Jet TM
PDB	Positive Displacement Dump Bailer	EBC	Expendable Bar Carrier
PPKR	Production Packer	EGUN	Bullet Guns
SB	Sinker Bar	EHC	Expendable Hollow Carrier
TTBP	Through-Tubing Bridge Plug	EMO SM	Electromagnetic Orientation Tool
Auxiliary		JJ	Jumbo Jet [®]
BHVC	Borehole Video Camera	PHC	Ported Hollow Carrier
CHTS	Cablehead Tension Sub	POL	Perforating Orientation Log
DIRO	Photoinclinometer	SJ	Silver Jet [®]
EMT	Electromagnetic Fishing Tool	TCP	Tubing-Conveyed Perforating
ORIT	Instrument Orienting Log		
PSM	Precision Subsidence Monitoring		
TFLR	Fluid Resistivity		
TTEM	Temperature		
TTEN	Tension		
TTRM SM	TTRM Sub		

Index

- Acceleration** (centripetal), A 17
- Additive** (cementing), I 16-I 19
- Air** (flow rate required for drilling), H 20
- Air drilling** (gas flow rate), H 20
- Allowable gain**, K 11
- Ampere**, A 20
- Anadrill** (downhole motors), E 26-E 29
- Angular** (velocity), A 17
- Angular frequency**, (electricity), A 22
- Annular space**, (volume), D 1
- Annulus** (area), A 14
- Annulus** (volume), D 1
- API grades**
casing, tubing, C 1
drill string, B 1
- API thread**, C 91-C 92
- Area** (combinations of nozzles), G 56-G 58
- Areas** (formulas), A 14
- Azimuth** (directional drilling), J 1, J 2, J 23
- B** (pressure loss coefficient), G 21, G 23-G 29
- Back-off** (drill string), K 24
- Bail**
hook, F 27-F 28
swivel, F 29
- Baker** (downhole motors), E 26-E 29
- Balanced tangent method** (directional drilling), J 20
- Barite** (mud weight increase), H 2, K 6
- Barrels** (US oil, conversion into m³), A 1
- Bearing friction** (rock bit), E 2-E 3
- Bentonite cements**, I 11-I 14
- Biaxial yield stress** (ellipse, casing), C 93-C 94
- Bingham** (fluid), G 13
- Bit**
comparison, E 5-E 7
diamond, E 8, E 9, E 12-E 16
rock bits (IADC classification), E 2-E 3
tolerance on new bit size, E 1
used bit dull grading system, E 14-E 16
- Blocks** (winch brake), F 31
- Blow-out** (control), K 1-K 17
- Bolts** (for flanges), L 4-L 10
- BOP, annular** (operating data, dimensions), L 20-L 34
- BOP, ram type**
dimensions and weights, L 25-L 31
operating data, L 20-L 24
- Brake** (block), F 31
- BSR** (drill collars), B 32
- Buckling** (critical buckling force of casing), C 97
- Buildup** (rate of), J 3, J 12-J 16
- Buoyancy** (factor), A 28
- Burst pressure**
drill pipe, B 16-B 18
tubing, casing, C 9-C 79
- Buttress** (thread form), C 91
- C90** (grade), C 1
- C95** (grade), C 1
- CaCl₂**, (solution), H 11
- Calcium chloride** (solution), H 11
- Cameron** (BOP), L 20, L 25, L 32
- Capacitance** (electricity), A 23
- Capacities**, D 4-D 11
- Capacitor** (electricity), A 23

Casing

- API (list), C 3, C 4
- collapse resistance, tensile load, C 93-C 94
- connections, C 35-C 79
- efficiency of connection, C 7, C 35-C 79
- geometry, C 35-C 79
- stress on cemented casing string, C 96-C 97

Celsius (conversion into Fahrenheit), A 10

Cement

- additives, I 16-I 18
- API specifications, I 4
- bentonite, I 11-I 12, I 14
- classes, I 3
- density, I 1
- weighted, I 15

Cementing

- displacement, I 20-I 21
- general data and units, I 1

Cenozoic (era), M 1

Centrifugal (force), A 18

Chains (rotary), F 34, F 35

Chalk (representation), M 5

Chromatograph (geological survey), M 8

Circle (area), A 14

Clamp (for CIW flanges), L 19

Classes (API cement), I 3

Classes of used drill pipe, B 4

Classification

- of drill pipes, B 4
- of fixed cutter bits, E 8-E 9
- of roller bits, E 2-E 3

Clay (representation), M 5

Clearance (casing/bit), D 2-D 3

Closing ratio, L 20-L 24

Closing (volume to close rams), L 20-L 34

Coal (representation), M 6

Code (color)

- casing-tubing, C 1, C 2
- drill pipe, B 5

Coiled tubing

- capacities, D 21-D 22
- dimensions, C 80-C 87
- performance, C 80-C 87

Collapse resistance

- drill pipe, B 16-B 18
- effect of tensile load (casing), C 93-C 94
- tubing, casing, C 9-C 79

Colloid (grain size), H 17

Color code

- casing, C 1-C 2
- drill pipe, B 5

Combined tension and torsion, B 54, B 55, B 59

Comparison

- of diamond bits, E 12-E 13
- of roller bits, E 5-E 7
- of PDC bits, E 10-E 11

Composite drill string, B 53

Compressibility (mud), M 11

Conductor pipe (line pipe), C 88-C 90

Cone (volume), A 14

Connection (star, mesh/delta), A 22

Content (solid) H 8, H 9

Convergence (directional drilling), J 1

Conversion factors, A 1-A 7

Coordinates (directional drilling), J 1, J 2

Coring (bit, thread, torque), E 18

Correction

- azimuth (directional drilling), J 23
- course (directional drilling), J 22
- drift angle (directional drilling), J 22

Correction factor

- make-up torque, C 8
- work of drilling line, F 24

Coulomb, A 20

Course (directional drilling), J 3-J 16

Course control (directional drilling), J 19-J 21

Course correction (directional drilling), J 22-J 23

Cretaceous, A 27, M 2

Critical (velocity), G 14

Cross-section (drill pipes), B 8-B 12

Current

- alternating, A 22, A 23
- direct, A 20, A 21

Curvature (directional drilling)

- minimum (method), J 21

- radius, J 3
- radius of borehole, J 24-J 25
- Cut-off practice** (drilling lines), F 23, F 24
- Cuttings** (amount in mud), G 10
- Cycle** (mud circulation), G 7
- Cylinder** (volume), A 14

- d** (exponent), M 10
- Dead line**, F 1
- Deca**, A 8
- Declination** (directional drilling), J 1
- Degrees API** (conversion into specific gravity), A 11
- Delta connection**, A 22
- Density**
 - annular mud, G 11
 - fracturing, K 11
 - kick control, K 6
- Detection** (gas, chromatography), M 8
- Diamond** (drill bits), E 1, E 8-E 16, E 18
- Dilution** (mud weight reduction), H 4, H 5
- Displacement**
 - calculation, J 19-J 21
 - directional drilling, J 4-J 16
 - slurry, cementing, I 20, I 21
- DLS** (Dog Leg Severity, directional drilling), J 21
- Dogleg** (directional drilling), J 17, J 18, J 21
- Dolomite** (representation), M 6
- Drift** (casing, tubing), C 6, D 2, D 3
- Drilex** (downhole motors), E 26-E 29
- Drill bit**
 - comparison of diamond bits, E 12-E 13
 - comparison of PDC bits, E 10-E 11
 - comparison of roller bits, E 5-E 7
 - diamond, IADC classification, E 8-E 9
 - rock bits, IADC classification, E 2-E 3
 - tolerance on new bit size, E 1
 - used bit dull grading system, E 14-E 16
- Drill collars**
 - characteristics, B 32
 - spiral, B 39
- Drill pipes**
 - dimensions, B 8- B 12
 - heavy-weight, B 47- B 48
- Drill string**
 - design calculations, B 52-B 59
- Drilled cuttings** (amount in mud), G 10
- Driller's** (control method), K 7
- Driller's procedures** (kick control), K 4-K 5
- Drum** (capacity), F 25
- Dull grading system** (used bits), E 14-E 16
- Duplex pumps** (output, liner size), G 3, G 4

- Eaton** (fracturing formula), M 11
- Efficiency**
 - casing values, C 35-C 79
 - definition, C 7
 - tubing values, C 9-C 34
 - reeving, F 3
 - volumetric, G 1
- EIPS** (Extra Improved Plow Steel), F 5
- Elastic modulus**, A 19
- Electricity**, A 22-A 23
- Elevator**
 - drill collars, B 40
 - drill pipes, F 26
- Elevator link arms** (capacity), F 26
- Ellipse**
 - area, A 14
 - of biaxial yield stress (casing), C 94
- Equivalent lengths**, G 68
- Evaporites** (representation), M 6
- External upset** (tubing), C 5

- Factor of safety**
 - drill pipe tension, B 52
 - drilling line, F 3
- Fahrenheit** (conversion into Celsius), A 10
- Fann viscometer** (measurements), G 13
- Farad**, A 23
- Fast line**, F 1
- FH** (thread), B 28
- Flanges**
 - 6B, L 4-L 6
 - 6BX, L 7-L 10
 - API, L 1-L 10
 - API (bolts), L 6-L 10
 - API (nominal dimensions), L 1

- Floating rig** (kick control), K 9-K 10
- Flow rate** (air drilling), H 20
- Form of casing/tubing threads**, C 91-C 92
- Fracturing**
density, K 11
gradient, M 11
- Free pipe** (determination of length), K 18-K 19
- Frequency** (electricity), A 22
- Friction bearing**
parameters, E 17
roller bits, E 2-E 3
- Frozen string** (determination of length of free pipe), K 18-K 19
- Full hole** (thread), B 30
- Gain** (allowable), K 11
- Gallons, US** (conversion into liters), A 3
- Gas**
kick (specific gravity), K 13
properties, M 8
- Giga**, A 8
- Grades API**
casing-tubing, C 1, C 2
drill string, B 1
- Gradient hydrostatic pressure**, H 1
- Grain size** (classification), H 20, M 4
- Grooves**
sheaves, F 21
stress relief (drill collars), B 37
- H₂S**
physical properties, M 9
steel for casings, C 2
- H40** (grade), C 1
- Halliburton**
abbreviations, M 12-M 13
downhole motors, E 26-E 29
- Heavy-weight DP**, B 47- B 48
- Hecto**, A 8
- Hematite** (weighted cements), I 15
- Hexagonal Kelly**, B 49, B 50
- Hole angle** (directional drilling), J 3-J 16
- Hooke's law**, A 19
- Hose** (vibrator and drilling), F 32, F 33
- Hub**, L 15, L 17
- Hughes** (rock bits), E 5-E 7, E 10-E 13, E 17
- Hydril** (BOP), L 21, L 22, L 26, L 33-L 37
- IADC**
classification of fixed cutter bits, E 8-E 13
classification of roller bits, E 2-E 7
- Identification** (used drill pipes) B 4
- IEU** (Internal/External Upset), B 2
- IF** (thread), B 30
- Ilmenite** (weighted cements), I 15
- Inch** (fractions of), A 9
- Inclination** (directional drilling) J 3-J 16
- Injection** (LOT), M 11
- Inertia**, A 15
- Insert** (roller bits), E 2, E 6-E 7, E 17
- Integral joint** (tubing), C 5
- Internal flush** (thread), B 30
- IPS** (Improved Plow Steel), F 5
- IU** (Internal Upset), B 2
- IWRC**, F 5
- J** (hole, directional drilling), J 3-J 7
- J55** (grade), C 1
- Joule** (electricity), A 21
- Jurassic**, A 27, M 2
- K₂CO₃** (solution), H 14
- K55** (grade), C 1
- KCl** (solution), H 12
- Kelly**
dimensions, B 49
mechanical strength, B 50
- Kick** (control), K 1-K 17
- Kick control methods**, K 7-K 9
- Kilo**, A 8
- Kilopascal** (conversion into psi), A 5
- Koomey** (BOP), L 24, L 30-L 31
- KOP** (directional drilling), J 3-J 11
- L80** (grade), C 1
- Lambert** (directional drilling), J 1, J 2
- Laminar** (flow), G 14

- Lang** (wire rope lay), F 5
- Leak Off Test, LOT**, M 11
- Length** (equivalent), G 68
- Limestone** (representation), M 5, M 6
- Line**
 dead, F 1
 fast, F 1
- Line pipe** (riser, conductor pipe), C 88-C 90
- Lobe** (positive displacement motor), E 23, E 26-E 29
- LOT**, M 11
- MAASP**, K 3, K 11, M 11
- Make-up torque**
 API flanges, L 14
 casing, tubing, C 8
 casing, tubing, values, C 9-C 79
 drill bits and core bits, E 18
 drill collars, B 41-B 46
 drill pipe, B 19-B 23
 heavy wall drill pipe (HW), B 48
- Mandrel** (casing, tubing), C 6
- Margin of Over Pull** (MOP), B 52
- Master bushing**, F 37, F 38
- Matting** (surface area), K 25
- Mechanics**, A 17- A 19
- Mega**, A 8
- Mesh** (screens), H 19
- Mesh connection**, A 22
- Mesozoic** (era), A 27, M 2
- Metals** (properties), A 26
- Minerals** (representation), M 5, M 6
- Moineau** (type, positive displacement motor), E 23-E 29
- Moment of inertia**
 of drill pipe (mm^4), B 8-B 12
 polar, A 15
- Mud flow rate** (well control), K 3
- Mud pumps**
 flow rate, G 1
 maximum pressure, G 2
- Mud weight**
 conversions, H 1
 equilibrium (kick control), K 6
 required (kick control), K 6
- N** (pressure loss coefficient), G 30-G 46, G 59-G 67
- N80** (grade), C 1
- NaBr** (solution), H 15
- NaCl** (solution), H 10
- Na_2CO_3** (solution), H 13
- NC** (numbered connections dimensions), B 30-B 31
- Newton**, A 6
- Newtonian** (fluid), G 13
- Neyrfor-Weir** (turbodrill), E 22, E 26-E 29
- Non upset** (tubing), C 5
- Nozzle**
 area, G 56-G 58
 pressure loss formula, G 19
 pressure loss/combination of three nozzles, G 47-G 52
 pressure loss/combination of two nozzles, G 53-G 55
- Ohm**, A 20
- Opening**
 ratio (BOP), L 20-L 24
 rotary table, F 37
 volume to open rams (BOP), L 25-L 34
- Operating parameters** (roller bits), E 17
- Ostwald** (or power fluid), G 13
- P110** (grade), C 1
- Paleozoic** (era), M 3
- Parallelogram** (area), A 14
- Pascal**, A 6
- PDC** (drill bit), E 8-E 11, E 14-E 18
- Period** (electricity), A 22
- Permafrost** (special steel), C 2
- Phase difference** (electricity), A 22
- PI** (value), A 12
- Piston load**, G 2
- Polar modulus of drill pipe** (mm^3), B 8-B 12
- Pore pressure**, M 10
- Positive displacement motor** (characteristics), E 23-E 29
- Potassium carbonate** (solution), H 14
- Potassium chloride** (solution), H 12

Power

- active (electricity), A 22
- applied (electricity), A 22
- at hook, F 2
- hydraulic, G 1, G 2
- hydraulic (nozzles), G 20
- nominal (positive displacement motor), E 26-E 29
- nominal (turbodrill), E 22
- reactive (electricity), A 22

Prehydrated (bentonite, cement), I 11-I 14

Premium (class of used drill pipe), B 4

Pressure

- hydrostatic, H 1
- pore, M 10
- working (well head), L 1

Pressure losses

- calculation example, G 22
- calculations, G 21, G 22
- equations, G 16-G 19
- equivalent length, G 68

Prism (volume), A 14

Procedures (driller's), K 4-K 7

Profile (well, directional drilling), J 3-J 16

Progressions (arithmetic and geometric), A 12

Projection (directional drilling), J 19-J 21

PS (Plow Steel), F 5

psi (conversion into kilopascals) A 7

Pyramid (volume), A 14

Q125 (grade), C 1

Quartzite (representation), M 5

Radius of curvature (directional drilling), J 3, J 21

Ragland diagram (directional drilling), J 17-J 18

Rate of build-up (directional drilling) J 3, J 12-J 16

Recess (drill collars), B 40

Redi Drill (turbodrill), E 22

Reed (rock bits), E 5-E 7

Reel (capacity), F 25

Regular

- threads, B 27
- wire rope lay, F 5

Resistance (electricity), A 21

Resistivity, A 20

Reynolds number (critical), G 14

Rheology, G 13

Ring-joint gaskets

- type BX, L 13
- type R, L 11
- type RX, L 12

Riser (line pipe), C 88-C 90

Rock bits

- comparison, E 5-E 7
- dull grading, E 14-E 16
- IADC classification, E 2-E 3
- operating parameters, E 17

Roller bearing (rock bits), E 2-E 3

Rotary speed

- nominal (positive displacement motor), E 26-E 29
- rock bits, E 17

Rotary table, F 37

S (hole, directional drilling), J 8-J 11

Sack (cementing), I 1, I 2

Safety margin (kick control), K 5, K 6

Sand

- grain size, H 17
- representation, M 5

Sandstone (representation) M 5

Schlumberger (abbreviations), M 14-M 15

Screen (shale shaker), H 18-H 19

Seale (steel wire rope), F 5

Secant method (directional drilling), J 20

Secondary (era), A 27

Security DBS (rock bits), E 5-E 7

Sediment (geology, representation), M 5, M 6

Severity (dogleg), J 21

Shaffer (BOP), L 23, L 27-L 29, L 38

Shale (representation), M 5

Shale shaker screens, H 18

Sheaves

- groove root radius, F 21
- sizes, F 20

Shoulder, low torque (drill collars), B 38**Shows** (symbols), M 7**SI units**, A 1**Silt**

- grain size, H 17
- representation, M 5

Slings (tension in), F 39**Slurry**

- density, I 6, I 9
- displacement, I 20-I 21
- preparation, cementing, I 5, I 7, I 8, I 10

Smith (rock bits), E 5-E 7**Sodium bromide** (solution), H 15**Sodium carbonate** (solution), H 13**Sodium chloride** (solution), H 10**Solid** (content), H 8, H 9**Spacer** (cementing), I 20-I 21**Specific gravity** (examples), A 25**Speed, nominal** (turbodrill), E 22**Sphere** (volume), A 14**Stages** (turbodrill), E 22**Star** (connection), A 31**Steel**

- casing, tubing, line pipe, C 1
- special (casing), C 2

Strand construction (typical), F 5**Stratigraphy** (scale), A 27**Strength**

- of materials, A 17
- of well, K 11, K 12

Stress (yield, biaxial, casing), C 93-C 94**Stretch** (drill pipes), B 51**Stuck pipe** (determination of length of free pipe), K 18-K 19**Symbols**

- chemical, A 24
- exploration (shows), M 7

T95 (grade), C 1**Tangent**, A 13**Tangent method** (directional drilling), J 20**Tanks, cylindrical**, A 16**Temperature**

- bottomhole (cementing), I 22
- influence on stresses, C 96-C 97

Tensile yield strength (drill pipes), B 13-B 15**Tera**, A 8**Ternary diagrams**, H 8, H 9**Thickening time** (cementing), I 4**Thread** (forms and dimensions), B 27**Threads**

- casing (API and buttress), C 91
- drill and core bits, E 18
- interchangeable, B 30-B 31
- rotary shouldered connections (characteristics), B 25
- tubing (API), C 92

Tolerance

- casing (bit), D 2, D 3
- on new bit size, E 1

Tool-joints (types and dimensions), B 8-B 12**Torque**

- maximum, positive displacement motor, E 26-E 29
- nominal, turbodrill, E 22

Torsion limit, B 54**Torsion**

- Hooke's law, A 19
- turns of, drill pipe, K 20-K 23

Torsional deformation formula, B 54**Torsional strength** (drill pipes), B 13-B 15**Trapezium** (area), A 14**Trend** (pore pressure), M 10**Triangle**

- area, A 14
- trigonometry, A 13

Trias, A 27, M 2**Trigonometry**, A 13**Trip margin** (kick control), K 5, K 6**Triplex pumps**

- maximum pressure, G 5
- output, liner size, G 6

TSP (drill bits), E 9, E 12-E 13

Tubing

- connections, C 9-C 34
- efficiency of connections C 9-C 34
- geometry, C 9-C 34
- list, C 5

Turbodrills (characteristics) E 19-E 22**Turbulent flow**, G 14**Turns** (of torsion, drill pipe), K 20-K 23**Units** (SI), A 1**Upset** (types and dimensions), B 2**UTM** (directional drilling), J 1**Varel** (rock bits), E 5-E 7**Velocity**

- angular, A 17
- at nozzles, G 20
- critical (fluid mechanics), G 14
- mud rise, G 9

Viscosity, G 13**Volt**, A 20**Volumes**

- annular space, D 12-D 21
- casing, D 9-D 10
- coiled tubing, D 22-D 23
- cylinders, D 1, D 4-D 5
- drill collars, D 8
- drill pipes, D 6-D 7
- formulas, A 14
- heavy wall (HW) drill pipes, B 47, B 48
- tubing, D 11

Wait and weight (control method), K 8-K 9**Warrington**, F 5**Watt** (electricity), A 21**Weight**

- annular BOP, L 25-L 38

drill collars, B 34

drill pipes, B 8-B 12

heavy wall (HW) drill pipes, B 47, B 48

kellies, B 49

mud (conversions), H 1

on bit (rock bits) E 17

ram-type BOP, L 20-L 31

steel wire rope, F 8-F 11

Weight increase

mud, H 2, H 3, K 6

weighted cement, I 15

Weight reduction

cement slurry, I 11-I 14

mud, H 4, H 5

Well (strength), K 11-K 12**Well control**

main symbols, K 1-K 2

preliminary calculations, K 3

Western Atlas (abbreviations), M 16-M 17**Wireline logging** (abbreviations), M 12-M 17**Wire rope**

API classification, F 5

nominal strength, F 8-F 11

sizes and construction, F 6, F 7

Wire rope twisting, F 5**WN** (rock bit parameter), E 17**WOB** (rock bit parameter), E 17**Work**

of a force, of a torque, A 18

of drilling line (formulas), F 22

Yield (slurry, cementing), I 5-I 8**Yield stress** (biaxial, ellipse, casing), C 93-C 94**Yield value**, G 13**Young's modulus**, A 19**Z** (ratio K of ZT), K 13

Achevé d'imprimé
Impression : EUROPE MEDIA DUPLICATION S.A.
F 53110 Lassay-les-Châteaux
N° 6291 - Dépôt légal : Avril 1999
N° d'éditeur 1010